

*****ATTACHMENTS*****

November 18, 2019

Resignation

Scott Matula from the Architectural Review Board effective immediately.

November 15, 2019

Mayor Michael Vandersteen
City Hall
828 Center Avenue
Sheboygan WI 53081

Dear Mayor Vandersteen

I, Scott Matula, hereby resign my position as a board member of the Architectural Review Board effective immediate.

Sincerely

Scott Matula



November 14, 2019

HONORABLE MEMBERS OF THE COMMON COUNCIL:

I hereby submit the following appointment for your consideration:

Cole Phillips to be considered for appointment to the Mayor's International Committee.

MICHAEL J. VANDERSTEEN, MAYOR

MAYOR'S OFFICE

CITY HALL
828 CENTER AVE.
SHEBOYGAN, WI
53081

920-459-3317
sheboyganwi.gov

1.5



November 1, 2019

HONORABLE MEMBERS OF THE COMMON COUNCIL:

I hereby submit the following appointment for your consideration:

Kay Hill to be considered for appointment to the Housing Authority to fill the unexpired term of Donald Tershner who term expires 4/20/2020.

A handwritten signature in blue ink that reads "Michael J. Vandersteen".

MICHAEL J. VANDERSTEEN, MAYOR

Lapover

MAYOR'S OFFICE

CITY HALL
828 CENTER AVE.
SHEBOYGAN, WI
53081

920-459-3317
sheboyganwi.gov

OCT 29 '19 AM 9:29

Thomas E. Howe
119 Long Court
Sheboygan, WI 53081
(612) 716-6311
tom.howe@sbcglobal.net

October 29, 2019

Ms. Meredith DeBruin, City Clerk
City of Sheboygan
Sheboygan City Hall
828 Center Avenue
Sheboygan, WI 53081

Dear Ms. DeBruin

This letter is to request that I be considered for the vacancy on the Board of Water Commissioners for the Sheboygan Water Utility.

I graduated from UW-Eau Claire with a bachelor's degree in Business Administration and completed master's coursework in the area of Industrial Management. While living in Minneapolis, I worked as an Industrial Engineer for Kroy Industries, Northern Telecom, SuperValu, and the Holiday Companies. Prior to retirement, I served as the Director of Distribution for Gander Mountain whose national distribution center was located in the Indianapolis area.

In addition, I served on the Board of United Way for Boone County (Indiana) for four years and was an active volunteer with Second Helpings, a food recovery and culinary training program, in Indianapolis for over three years.

Since moving to Sheboygan six years ago, I have been a volunteer and "on-call" maintenance person for Meals on Wheels, a "Lunch Buddy" in the Sheboygan Area School District through Big Brothers/Big Sisters, and am active in the Sheboygan A's organization through Board membership and volunteer activities.

I believe it is crucial for citizens to give back to the communities they live in when they are able to do so. Serving as a commissioner for the Sheboygan Water Utility is important to me because few things are as important to a community as clean, safe water.

Sincerely



Thomas E. Howe

c: Mayor Mike Vandersteen
Alderman Todd Wolf

II

R. O. No. _____ - 19 - 20. By CITY CLERK. November 18, 2019.

Submitting the Tax Levy Certification for the 2019-2020 school year from the Sheboygan Area School District.

Consent.

CITY CLERK

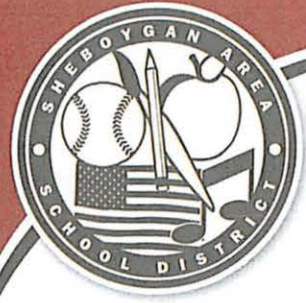

SHEBOYGAN
AREA SCHOOL DISTRICT
Learning Today. Leading Tomorrow.

830 Virginia Avenue
Sheboygan, WI 53081
Ph. (920) 459-3523
Fax (920) 459-4300

November 1, 2019

City of Sheboygan
Municipal Clerk - Meredith DeBruin
828 Center Avenue
Sheboygan, WI 53081-4442

Dear Meredith:

The Board of Education for the Sheboygan Area School District approved the following Tax Levy for the 2019-2020 school year:

School Levy	\$35,622,388.00
Recreation Levy	\$ 1,356,528.00

Enclosed are the tax levy certifications as assessed against the taxable property of that portion of the school district and/or recreation district lying within your municipality as required by section 120.17(8).

The levy payment must be received in the Business Office by the due date. If there are any questions, please feel free to contact me at 920-459-3955.

Sincerely,

Mark Boehlke
Assistant Superintendent
Business and Operational Services

Enclosure (1)

1. The first part of the document is a list of names and addresses of the members of the committee.

2. The second part of the document is a list of the names of the members of the committee who have been elected to the office of chairman and vice-chairman.

3. The third part of the document is a list of the names of the members of the committee who have been elected to the office of secretary and treasurer.

4. The fourth part of the document is a list of the names of the members of the committee who have been elected to the office of member-at-large.

5. The fifth part of the document is a list of the names of the members of the committee who have been elected to the office of member-at-large.

6. The sixth part of the document is a list of the names of the members of the committee who have been elected to the office of member-at-large.

7. The seventh part of the document is a list of the names of the members of the committee who have been elected to the office of member-at-large.



Instructions: This form must be signed in the presence of a notary public, and delivered to the clerk of each municipality having territory within the school district on or before **November 10**.
 (Ref Wisconsin Statute s.120.12(3))

2019-2020 School Year

T O 1. Municipal Clerk: MEREDITH DEBRUIN
 828 CENTER AVE
 SHEBOYGAN, WI 53081-4442

2. Municipality: City of Sheboygan

3. County: Sheboygan County

The levy is distributed using the same percentage as the equalized valuation.

	Entire School District	Portion of School District Lying Within Municipality
	Column 1	Column 2
4. Equalized Valuation (TID Out) Tax Apportionment (October Certification)	\$3,794,244,110.00	\$2,472,887,412.00
5. Percent of Entire School District	100.000000%	65.174705%
6. Total Levy	\$36,978,916.00	\$24,145,945.00

CERTIFICATION

I HEREBY CERTIFY the amount shown on Line 6, Column 2, above, to be assessed against the taxable property of that portion of the school district lying within the municipality, as required by s. 120.17 (8). The state superintendent, pursuant to s. 121.06, has certified to me the equalized valuations shown on Line 4, which I have used to determine the portion of the school district levy to be paid by the municipality.

NOTARY SEAL	F Name of School District	School District Clerk
	R Sheboygan Area (5271)	Jennifer Pothast
	O Signature of School District Clerk	<i>Jennifer Pothast</i>
	M Signature of Notary Public	<i>Jennifer J. Heus</i>
	Signed before me this date	My Commission Expires
	<i>10/31/19</i>	<i>9/13/2023</i>

Wisconsin Statutory References:
 s.120.17(8)
 s.120.44
 s.121.06(2)

Mail tax settlement to: District Administrator
 Sheboygan Area School District
 830 Virginia Ave
 Sheboygan, WI 53081-4427

2021-10-27 14:00
OILEUF YRATON
DREXCOSSIA PO-ETATE



Wisconsin Department of Public Instruction

PI-1508 TAX LEVY CERTIFICATION

ss. 24.71, 120.17 (8)

Per §74.09(3)(b) a school board is required to separately report any tax levies that exceed its annual revenue limit as a result of a successful referendum to exceed the limit on a non-permanent basis. State law requires the levies associated with all debt and non-recurring operation referendums passed after December 31, 2014 to be listed separately. The property tax bill must also include the year in which the non-permanent referendum to exceed the revenue limit no longer applies.

2019-2020 School Year

List of approved 2019-2020 debt and non-recurring operating referenda which will allow the district to exceed its revenue limit on a non-permanent basis.

Municipal Clerk: MEREDITH DEBRUIN
828 CENTER AVE
SHEBOYGAN, WI 53081-4442
Municipality: City of Sheboygan
County: Sheboygan County
School District: Sheboygan Area (5271)
School District Clerk: Jennifer Pothast

Table with 8 columns: Referenda ID, Vote Date, Type, Year Expires, Total Referendum Amount, 2019-2020 Levy Amount due to Referendum, Percent of Entire School District, 2019-2020 Amount due to Referendum for Taxation District. Row 1: RF-3992, 11/8/2016, Issue Debt, 2037, \$29,000,000, \$888,787.00, 65.174705167%, \$579,265.00



R. O. No. _____ - 19 - 20. By CITY CLERK. November 18, 2019.

Submitting various license applications.

City Clerk

COMMERCIAL OPERATOR LICENSE (RENEWAL)

<u>No.</u>	<u>Name</u>	<u>Address</u>
1945	A & M Trees LLC	7230 Sauk Trail Road
2048	Brian T Kath Tree Trimming	1612 S. 8 th Street
1059	Castle Pine Land Improvement	W2626 Schneider Road, Sheboygan Falls
3264	Chris Lewis Tree Surgery	PO Box 1564, Manitowoc
3200	East Central Fly Guy LLC	N1883 Dewitt Road, Oostburg
2961	Eisentraut Lawn Care	404 Roosevelt Ave, Howards Grove
3042	Evergreen Lawn & Land LLC	412 Broadway Street, Sheboygan Falls
1154	Harolds Landscaping LLC	W4740 Cty MM, Elkhart Lake
3249	Hoppe Tree Service	1813 S. 73 rd Street, Milwaukee
2617	Lawn Ranger	2622 Grey Fox Court
2012	M & K Lawn Services	145 Foxglove Lane, Sheboygan Falls
1814	Morse Landscaping LLC	2737 N. 21 st Street
1322	Serenity Farm Landscaping Inc.	2803 Old Park Road
1315	Schmidts Landscaping	W3127N Cty A, Sheboygan Falls
1385	Stevie Bs Landscaping	N7332 Lakeshore Road
3068	Stuebs Lawn and Landscape	N3328 Tipperary Road, Cascade
2473	Stump Eliminators, LLC	726 N. 25 th Street
1943	T & M Lawn Builders/Care LLC	N4338 Claver Ct Rd., Sheboygan Falls
1770	TDN Utility Services	1075 Fond du Lac Ave., Sheboygan Falls
3317	The Plymouth Landscape Co. LLC	W6397 Oak View Lane, Plymouth
2132	Top Notch Tree & Stump Removal	931 Beech Street, Cleveland
1984	Trugreen	2015 W Spencer Street, Appleton

SECONDHAND DEALER LICENSE (RENEWAL)

<u>No.</u>	<u>Name</u>	<u>Address</u>
3386	ecoATM	1317 N. 25 th Street
3380	ecoATM	3711 S. Taylor Drive
1132	Gibson Girls	322 Bell Avenue
2852	Heritage Showcase	1614 Indiana Avenue
1187	Kisiolek Jewelers	1103 N. 8 th Street
1302	Rudnick Jewelers	919 N. 8 th Street

Consent.

TEMPORARY CLASS "B" LICENSE (UPDATED)

No. Name

Address

3030 Sheboygan County Humane Society

3107 N. 20th Street - 3 day event
to be held at the EBCO Building
1201 Erie Avenue to include beer
and wine.

II

R. O. No. _____ - 19 - 20. By CITY CLERK. November 18, 2019.

Submitting the State and County Apportionment Form from the County Board of Supervisors to determine the amount of taxes to be levied in Sheboygan County against all taxable property for the year.

Consent.

CITY CLERK

NOV 14 '18 11:21:18

Attention Clerks:

Attached are the apportionment sheets for 2019. Please make sure you do not round any of the numbers listed. You must collect exactly the amounts on the form.

State and County Apportionment Form

Year 2019 CoMuni Code 59281 Account Number 1623 CITY OF SHEBOYGAN

A. STATE TAXES (Apportioned TID IN)		
1. Aggregate amount of state tax (use this amount to calculate state tax rate)		\$0.00
B. COUNTY TAXES (Apportioned TID OUT)		
B1. Portion of state special charges on county:		
2. Charitable and penal		\$444.31
3. Other state special charges		\$0.00
4. SUBTOTAL - Section B1 (also enter on Line B1 on Statement of Taxes (SOT))		\$444.31
B2. Other county taxes levied over entire town, village or city		
5. Health		
6. Library (sec. 43.12, Wis. Stats.)		
7. County Bridge Aid (sec. 82.08(2), Wis. Stats.)		
8. Sanitation		
9. Children with Disabilities Education Boards (over entire town,village or city) (sec.121.135, Wis. Stats.)		
10. Property taxes charged back (sec. 74.41 & 74.42, Wis. Stats.)		
11. Countywide EMS		
12. Other (describe) :		
13. All other county taxes (levied over every town, village, and city)		\$13,784,648.85
14. County Sales Tax Credit		
15. SUBTOTAL - Section B2 Taxes to be levied over entire municipality (enter on Line B2 on SOT)		\$13,784,648.85
B3. County taxes levied over part of town, village or city (also enter on line B3 on SOT)		
16. Children with Disabilities Education Boards		\$0.00
17.		
18.		
19.		
20.		
21. TOTAL NET COUNTY TAXES (sum of sections B1 through B3) (for county tax rate)		\$13,785,093.16
C. SPECIAL DISTRICT TAXES		
22. Special district code: NA	Amount levied	\$0.00
23. Special district code: NA	Amount levied	\$0.00
D. TOWN, VILLAGE OR CITY TAXES		
D1. Other state special charges		
24. Other:		
25. Other:		
26. SUBTOTAL - Section D1 (also enter on Line D4 on SOT)		\$0.00
D2. County Special Charges:		
27. Illegal real estate charged back (sec. 70.74(2), Wis. Stats.)		\$0.00
28. Highways and bridges (sec. 83.03, Wis. Stats.)		\$0.00
29. Highway aid (sec. 83.14, Wis. Stats.)		\$0.00
30.		
31.		
32.		
33.		
34. SUBTOTAL - Section D2 (also enter on Line D5 on SOT)		\$0.00
35. TOTAL - ALL TAXES AND CHARGES - sum of sections A through D		\$13,785,093.16

1 SHEBOYGAN COUNTY RESOLUTION NO. 18 (2019/20)

2
3 Re: Levying and Apportioning the Tax
4
5

6 WHEREAS, each year, the County Board of Supervisors is required to determine the
7 amount of taxes to be levied in Sheboygan County against all taxable property for the year, and
8

9 WHEREAS, this year there are four (4) components of the tax amount that must be
10 included, and
11

12 WHEREAS, the first component is the State Special Charge pursuant to Wis. Stat.
13 §§ 51.20(18) and 70.60 to reimburse other counties for expenses related to mental
14 commitments of Sheboygan County residents in their counties charged against all taxable
15 properties in Sheboygan County in the amount of \$1,579.50 (Equalized Rate: .000000163), and
16

17 WHEREAS, the second component is the County Aid to Bridges required by Wis. Stat.
18 § 82.08 and approved by the County Board by Resolution No. 14 (2019/20) charged against all
19 taxable property in the townships in Sheboygan County in the amount of \$156,051.00
20 (Equalized Rate – Town only: .000039416), and
21

22 WHEREAS, the third component is the Sheboygan County portion of the Monarch
23 Library System approved for the budget and an apportionment adjustment for the Monarch
24 Library System and required by Wis. Stat. § 43.64 to be charged against all taxable property in
25 all townships except the Towns of Scott and Sherman and all villages except the Villages of
26 Adell, Cedar Grove, Elkhart Lake, Kohler, Oostburg, and Random Lake in the amount of
27 \$1,438,562.00 (Equalized Rate: .000357695, applied to non-excluded Towns and Villages only),
28 and
29

30 WHEREAS, the fourth and largest component is the general County property tax
31 pursuant to Wis. Stat. § 70.62 to finance the County government budget, and
32

33 WHEREAS, the Sheboygan County Board, after public hearing, study, and revision has
34 finalized and adopted the 2020 budget on this 5th day of November, 2019, which requires a levy
35 of \$49,003,538.00 against all taxable property in the County of Sheboygan (Equalized Rate:
36 .005060034), and
37

38 WHEREAS, subject to Wis. Stat. § 66.0602(3)(fm), the County Board may increase the
39 levy limit up to a maximum adjustment allowed under said statute by a 2/3 majority vote of the
40 County Board;
41

42 NOW, THEREFORE, BE IT RESOLVED, that by a 2/3 majority vote of the Sheboygan
43 County Board there be and hereby is levied on all taxable property in the County of Sheboygan
44 the following taxes:
45

46 State Special Charges
47 Wis. Stat. § 51.20(18) (Equalized Rate: .000000163) \$1,579.50

STATE OF WISCONSIN) I, Jon Dolson do hereby
COUNTY OF SHEBOYGAN) certify that the above is a
true and correct copy of the original on file in the office of the
County Clerk and that it was adopted by the County Board of
Supervisors on this date.

Date: 11/25/19 
(Seal) County Clerk

STATE OF WISCONSIN
COUNTY OF [illegible]
I, the undersigned, being duly qualified as a Justice of the Peace for the County of [illegible] in the State of Wisconsin, do hereby certify that the above is a true and correct copy of the [illegible] as the same appears in the records of the County of [illegible] in the State of Wisconsin, this [illegible] day of [illegible] 19[illegible].

[Signature]
Justice of the Peace

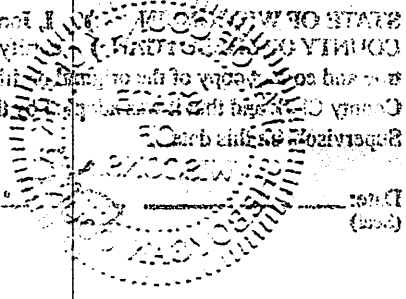

Date: _____
(Date)

50 General County Taxes \$49,003,538.00
51 Wis. Stat. § 70.62, (Equalized County Rate: .005060034)
52

53 **BE IT FURTHER RESOLVED** that the sum of \$1,438,562.00, which is the amount
54 approved for the budget of the Monarch Library System, pursuant to Wis. Stat. § 43.64, be and
55 hereby is levied against all taxable property in the townships, excluding the Towns of Scott and
56 Sherman, and all villages, excluding the Villages of Adell, Cedar Grove, Elkhart Lake, Kohler,
57 Oostburg, and Random Lake.

58
59 (Equalized Rate: .000357695)
60

61 **BE IT FURTHER RESOLVED** that the sum of \$156,051.00 County Aid to Bridges as
62 approved by Resolution No. 14 (2019/20) be and hereby is levied against all taxable property in
63 the townships in Sheboygan County.

64
65 (Equalized Rate: .000039416)
66

67 **BE IT FURTHER RESOLVED** that the County Clerk and the County Finance Director
68 shall, pursuant to Wis. Stat. § 70.63 determine and apportion within ten (10) days of this date,
69 the tax levy set forth for the respective municipalities, according and in proportion to the
70 valuations for the towns, villages, and cities as submitted by the Wisconsin Department of
71 Revenue.

72
73
74 Respectfully submitted this 5th day of November, 2019.
75

76
77 **FINANCE COMMITTEE**

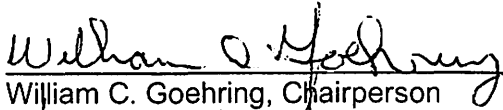
78
79
80 
81 William C. Goehring, Chairperson

82 Roger L. Te Stroete, Vice-Chairperson

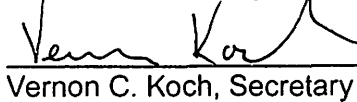
83 
84 Vernon C. Koch, Secretary

85
86
87
88
89
90
91
92
93
94
95
96
97
Keith Abler

Gerald Jorgensen

Opposed to Introduction:

SHEBOYGAN COUNTY RESOLUTION NO. 17 (2019/20)

Re: Approving 2020 Budget

WHEREAS, the County Executive Committee, the County Finance Committee, the County Administrator, and the County Finance Director have formulated a County budget for 2020 using the process required by Chapter 5 of the County Code and Wis. Stat. § 65.90, and

WHEREAS, Section 5.06(a)(6) requires the Finance Committee to submit the proposed full budget in Resolution form to the full County Board for approval, and

WHEREAS, the Finance Committee prepared the proposed 2020 County budget as submitted to the Board on October 29, 2019, a copy of which is on file with the County Clerk, and;

WHEREAS, the proposed budget was subject to potential preliminary amendments adopted by the County Board on October 29, 2019, and further potential Finance Committee amendments, any of which are reflected on the Committee report attached to the proposed 2020 budget, and

WHEREAS, the Finance Committee believes that the proposed 2020 County Budget as may be amended pursuant to the Committee Report is in the best interests of Sheboygan County and its taxpayers, and

WHEREAS, the budget includes a levy adjustment under Wis. Stat. § 66.0602(3)(fm) which will require a 2/3 vote of the County Board;

NOW, THEREFORE, BE IT RESOLVED that the Sheboygan County Board adopts the proposed 2020 budget as submitted to the Board on October 29, 2019, as may be amended pursuant to the Finance Committee report, both of which are on file with the County Clerk.

Respectfully submitted this 5th day of November, 2019.

FINANCE COMMITTEE



William C. Goehring, Chairperson



Roger Te Stroete, Vice-Chairperson



Vernon Koch, Secretary

Keith Ablter

Gerald Jorgensen

STATE OF WISCONSIN) I, Jon Dolson do hereby
COUNTY OF SHEBOYGAN) certify that the above is a
true and correct copy of the original on file in the office of the
County Clerk and that it was adopted by the County Board of
Supervisors on this date.

Date: 11/05/19 
(Seal) _____
County Clerk

1964

April 15, 1964

Dear Mr. [Name]:

I have your letter of April 10, 1964, regarding the [subject]. I am sorry that I cannot provide you with a more definitive answer at this time, but the [reason] is that the [information] is still being reviewed.

I will be sure to contact you again as soon as a final decision has been reached. Thank you for your patience and understanding.

Sincerely,
[Signature]

1964

April 15, 1964

Dear Mr. [Name]:

I have your letter of April 10, 1964, regarding the [subject]. I am sorry that I cannot provide you with a more definitive answer at this time, but the [reason] is that the [information] is still being reviewed.

I will be sure to contact you again as soon as a final decision has been reached. Thank you for your patience and understanding.

Sincerely,
[Signature]

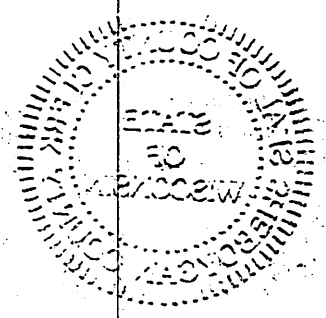

II

R. O. No. - 19 - 20. By CITY PLAN COMMISSION. November 18, 2019.

Your Commission to whom was referred Gen. Ord. No. 32-19-20 by Alderpersons Bohren and Wolf repealing and recreating Section 15.905 and Subsection 15.908 (1) of the City of Sheboygan Zoning Ordinance (SZO), so as to amend certain portions thereof so as to clarify any ambiguities in the Municipal Code relating to Conditional Use Permits, to incorporate into the Municipal Code established past practices of the Plan Commission relative to Conditional Uses, and to conform the Municipal Code to 2017 Wis. Act 67 and Sec. 62.23(7)(de), Wis. Stats.; wishes to report this matter was discussed at the regular meeting of the City Plan Commission, November 12, 2019, and after due consideration, recommends receiving the R. O. and adopting the General Ordinance.

Consent

CITY PLAN COMMISSION

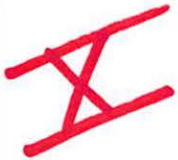

6.1

Gen. Ord. No. 32 - 19 - 20. By Alderpersons Bohren and Wolf.
November 4, 2019.

AN ORDINANCE repealing and recreating Section 15.905 and Subsection 15.908(1) of the City of Sheboygan Zoning Ordinance (SZO), so as to amend certain portions thereof so as to clarify any ambiguities in the Municipal Code relating to Conditional Use Permits, to incorporate into the Municipal Code established past practices of the Plan Commission relative to Conditional Uses, and to conform the Municipal Code to 2017 Wis. Act 67 and Sec. 62.23(7)(de), Wis. Stats.;

WHEREAS, Section 15.905 of the SZO governs the procedure and requirements for the review and approval, or denial, of proposed Conditional Uses; and

WHEREAS, since the City of Sheboygan adopted its current Zoning Ordinance, Subchapter 15 of the Municipal Code, certain ambiguities and inconsistencies have been identified; and

WHEREAS, in practice, City Plan Commission has been the body with the most experience in evaluating and administering Conditional Uses as well as authorizing appropriate exceptions and/or exceedances to the Municipal Code in connection with considering and approving, denying and/or crafting conditions relating to Conditional Use Permits; and

WHEREAS, 2017 Wisconsin Act 67 created Sec. 62.23(7)(de), Wis. Stats., which provides at Subsection 20: "If an applicant for a Conditional Use Permit meets, or agrees to meet, all of the requirements and conditions specified in the City Ordinance, the City shall grant the Conditional Use Permit. Any condition imposed must be related to the purpose of the Ordinance and be based on substantial evidence;" and

WHEREAS, this Ordinance is an amendment to the Sheboygan Zoning Ordinance, which will be referred to the Plan Commission, and which will require publication of a class 2 notice and a public hearing prior to adoption; and

WHEREAS, this Ordinance is adopted to promote the health, safety, and welfare of the people of the City of Sheboygan;

NOW, THEREFORE, THE COMMON COUNCIL OF THE CITY OF SHEBOYGAN DO ORDAIN AS FOLLOWS:

Section 1. Section 15.905 of the City of Sheboygan Zoning Ordinance is repealed and recreated to read as follows:

City Plan

Section 15.905 Conditional Use Review and Approval

(1) **Purpose:**

- (a) The purpose of this Section is to provide regulations which govern the procedure and requirements for the review and approval, or denial, of proposed conditional uses.
- (b) Certain uses in situations which are of such a special nature, or are so dependent upon actual contemporary circumstances, as to make impractical the predetermination of permissibility, or the detailing in this Chapter of specific standards, regulation, or conditions which would permit such determination in each individual situation, may be permitted as conditional uses.
- (c) Conditional uses are also those proposed uses which are listed as special uses, but fail to meet one of the requirements for special use approval listed in Section 15.206. (See Section 15.202(3)(b)).
- (d) If an applicant for a Conditional Use Permit meets or agrees to meet all of the requirements and conditions specified in the Municipal Code or imposed by the Plan Commission, the City shall grant the Conditional Use Permit. Any condition imposed must be related to the purpose of the Zoning Ordinance and be based on substantial evidence. Under this Section 15.905, "substantial evidence" means facts and information, other than merely personal preferences or speculation, directly pertaining to the requirements and conditions an applicant must meet to obtain a Conditional Use Permit and that reasonable persons would accept in support of a conclusion. This subsection is intended to ensure compliance of Section 15.905 of the Municipal Code with 2017 Wisconsin Act 67 and Sec. 62.23(7)(de), Wis. Stats.

(2) **Initiation of Request for Approval of a Conditional Use:** Proceedings for approval of a conditional use may be initiated by an application of the owner(s) of the subject property.

(3) **Application Requirements:** All applications for proposed conditional uses shall be approved as completed by the Zoning Administrator prior to the initiation of this procedure. No placement of the application on any agenda, as an item to be

... ..
... ..
... ..

... ..
... ..
... ..

... ..
... ..
... ..

... ..
... ..
... ..

... ..
... ..
... ..

... ..
... ..
... ..

... ..
... ..
... ..

... ..
... ..
... ..

... ..
... ..
... ..

... ..
... ..
... ..

... ..
... ..
... ..

... ..
... ..
... ..

... ..
... ..
... ..

... ..
... ..
... ..

... ..
... ..
... ..

... ..
... ..
... ..

... ..
... ..
... ..

... ..
... ..
... ..

... ..
... ..
... ..

... ..
... ..
... ..

... ..
... ..
... ..

... ..
... ..
... ..

... ..
... ..
... ..

... ..
... ..
... ..

... ..
... ..
... ..

... ..
... ..
... ..

... ..
... ..
... ..

acted upon, shall occur unless said certification has occurred. The item may be placed on any agenda as a discussion-only item, without an application. Prior to the submittal of the Official Notice regarding the application to the newspaper, the applicant shall provide 5 copies of the complete application. Said complete application shall be comprised of all of the following:

- (a) A map of the subject property showing all lands for which the conditional use is proposed, and all other lands within 200 feet of the boundaries of the subject property, together with the names and address of the owners of all lands on said map as the same appear on the current records of the Register of Deeds of Sheboygan County. Said map shall clearly indicate the current zoning of the subject property and all other land within 200 feet, and the jurisdiction(s) which maintains that control. Said map and all its parts and attachments shall be submitted in a form which is clearly reproducible with a photocopier, and shall be at a scale which is not less than one inch equals 800 feet. All lot dimensions of the subject property, a graphic scale, and a north arrow shall be provided;
- (b) A map, such as the Land Use Plan Map, showing the generalized location of the subject property in relation to the City as a whole;
- (c) A written description of the proposed conditional use, describing the type of activities, buildings, and structures proposed for the subject property and their general locations;
- (d) A site plan of the subject property as proposed for development. Said site plan shall conform to any and all the requirements of Section 15.206(1)(b) or a group development (per Section 15.208). A proposed preliminary plat or conceptual plat may be substituted for the required site plan, provided said plat contains all information required on said site plan per section 15.908. Review and approval of any site plan, preliminary plat or conceptual plat submitted with an application for a Conditional Use Permit under this Section 15.905 also shall constitute Site Plan Review and Approval under Section 15.908 of the Municipal Code.
- (e) Additionally, the applicant may wish to provide written justification for the proposed conditional use consisting of the reasons why the applicant believes the proposed

conditional use is appropriate, particularly as evidenced by compliance with the standards set forth in Subsection 15.905(4)(c)1-6.

(4) **Review by the Zoning Administrator:** The proposed conditional use shall be reviewed by the Zoning Administrator as follows:

(a) The Zoning Administrator shall determine whether the application is complete and fulfills the requirements of this Chapter. If the Zoning Administrator determines that the application is not complete or does not fulfill the requirements of this Chapter, he shall return the application to the applicant. If the Zoning Administrator determines that the application is complete, he shall so notify the applicant.

(b) Upon notifying the applicant that his application is complete, the Zoning Administrator shall review the application and evaluate and comment on the written justification for the proposed conditional use.

(c) The Zoning Administrator may also evaluate the application to determine whether the requested conditional use is in harmony with the recommendations of the City's Comprehensive Master Plan, particularly as evidenced by compliance with the standards of Subsection (4)(c)1-6 below:

1. How is the proposed conditional use (the use in general, independent of its location) in harmony with the purposes, goals, objectives, policies and standards of the City of Sheboygan Comprehensive Plan, this Chapter, and any other plan, program, or ordinance adopted, or under consideration pursuant to official notice by the City?

2. How is the proposed conditional use (in its specific location) in harmony with the purposes, goals, objectives, policies and standards of the City of Sheboygan Comprehensive Plan, this Chapter, and any other plan, program, or ordinance adopted, or under consideration pursuant to official notice by the City?

3. Does the proposed conditional use, in its proposed location and as depicted on the required site plan, result in a substantial or undue adverse impact on nearby property, the character of the neighborhood,

environmental factors, traffic factors, parking, public improvements, public property or rights-of-way, or other matters affecting the public health, safety, or general welfare, either as they now exist or as they may in the future be developed as a result of the implementation of the provisions of this Chapter, the Comprehensive Plan, or any other plan, program, map, or ordinance adopted or under consideration pursuant to official notice by the City or other governmental agency having jurisdiction to guide development?

4. Does the proposed conditional use maintain the desired consistency of land uses, land use intensities, and land use impacts as related to the environs of the subject property?
5. Is the proposed conditional use located in an area that will be adequately served by, and will not impose an undue burden on any of the improvements, facilities, utilities or services provided by public agencies serving the subject property?
6. Do the potential public benefits of the proposed conditional use outweigh any and all potential adverse impacts of the proposed conditional use after taking into consideration the applicant's proposal and any requirements recommended by the applicant to ameliorate such impacts?

(d) The Zoning Administrator shall forward the report to the Plan Commission for the Commission's review and use in making its decision. If the Zoning Administrator determines that the proposal may be in conflict with the provisions of the City's Comprehensive Master Plan, the Zoning Administrator shall note this determination in the report.

(5) Review by the Plan Commission and Public Hearing:

- (a) The Plan Commission shall schedule a public hearing to consider the application within 45 days after the acceptance and determination of the complete application as determined by the Zoning Administrator, the applicant may appear in person, or by agent, and/or by attorney. Said notice shall contain a description of the subject property and the proposed conditional use. In addition, at least seven days before said public hearing, the Zoning Administrator shall mail an identical notice to the

applicant and to all owners of abutting properties. Failure to mail said notice, provided it is unintentional, shall not invalidate proceedings under this Section. Notice of the public hearing shall be published as a class 2 notice under Chapter 985, Wis. Stats.

- (b) Within 60 days after the public hearing (or within an extension of said period requested in writing by the applicant and granted by the Plan Commission), the Plan Commission shall make its findings. The Plan Commission shall state in the minutes and in a substantially issued written Conditional Use Permit or in a written notice to the applicant of denial of the Conditional Use Permit, its conclusions, findings of fact, conditions, and any substantial evidence supporting such conclusions, findings of fact, and conditions.
- (c) For existing developments that do not meet the landscaping and paving requirements of this Chapter, the Plan Commission may choose to require the development paving and landscaping to come into compliance with the requirements per Section 15.307.
- (d) Notwithstanding anything in the Zoning Ordinance to the contrary, in connection with the granting of a Conditional Use Permit under this Section 15.905, the Plan Commission may authorize the exception from, or exceedance of, any nonresidential bulk or dimensional standards set forth in Subsections 15.206(3)-(10) (Detailed Land Use Descriptions and Regulations), 15.305 (Nonresidential Intensity Standards), 15.403 (Nonresidential Bulk Standards), 15.405 (Intrusions into Required Yards), 15.406 (Exceptions to Maximum Height Regulations), 15.607 (Landscaping Requirements for Paved Areas), 15.610 (Landscaping Requirements in Bufferyards), 15.704(7) (Calculation of Minimum Required Parking Spaces), 15.705(11) (Calculation of Required Loading Spaces), 15.720(3) (Fencing Standards), or Subchapter 15-8 (Signage Regulations). Any exception to, or exceedance of, any nonresidential bulk or dimensional standards shall be determined by the Zoning Administrator to be in harmony with the City's Comprehensive Plan particularly evidenced by compliance with the standards of Subsections 15.905(4)(c) 1.-6. Any exception to, or exceedance of, nonresidential bulk or dimensional standards authorized by the Plan Commission shall not be considered a variance, provided that the exception or

exceedance and the justification for the exception or exceedance are specifically stated in the Conditional Use Permit.

- (6) **Plan Commission Action:** The Plan Commission may take final action on the application at the time of its initial consideration of the written conditional use permit, or may continue the proceedings at its discretion or at the applicant's request. The Plan Commission may approve the conditional use as originally proposed, may approve the proposed conditional use with modifications, or may deny approval of the proposed conditional use. The Plan Commission's approval of the proposed conditional use shall be considered the approval of a unique request, and shall not be construed as precedent for any other proposed conditional use.
- (7) **Effect of Denial:** No application which has been denied (either wholly or in part) shall be resubmitted for a period of 6 months from the date of said order of denial, except on grounds of new evidence or proof of change of factors found valid by the Zoning Administrator.
- (8) **Termination of an approved Conditional Use:** Upon approval by the Plan Commission, the applicant must demonstrate that the Conditional Use, as established and implemented, meets all general and specific Conditional Use requirements and conditions approved under this Section, including all general and specific conditional use requirements in the site plan. Once a Conditional Use Permit is granted, no Erosion Control Permit, Site Plan approval (per Section 15.908), Certificate of Compliance, Building Permit or Occupancy Permit shall be issued for any development which does not comply with all requirements and conditions of the Conditional Use Permit. The applicant shall provide Certification of Compliance to the City staff upon completion of the development activity. Any conditional use found not to be in compliance with the terms of this Chapter shall be considered in violation of this Chapter and shall be subject to all applicable procedures and penalties. A conditional use may be revoked for such a violation by majority vote of the Plan Commission, following the procedures outlined in Subsections (2) through (7), above.
- (9) **Time Limits on the Development of Conditional Use:** The start of construction of any and all conditional uses shall be initiated

within 365 days of their approval by Plan Commission and shall be operational within 730 days of said approval. Failure to initiate development within this period shall automatically constitute a revocation of the conditional use. For the purposes of this Section, "operational" shall be defined as the granting of a Certificate of Compliance for the conditional use. Prior to such a revocation, the applicant may request an extension of this period. Said request shall require formal approval by Plan Commission and shall be based upon a showing of acceptable justification (as determined by Plan Commission).

- (10) **Discontinuing an Approved Conditional Use:** Any and all conditional uses which have been discontinued for a period exceeding 365 days shall have their conditional use invalidated automatically. The burden of proof shall be on the property owner to conclusively demonstrate that the subject conditional use was operational during this period.
- (11) **Change of Ownership:** All requirements of the approved conditional use shall be continued regardless of ownership of the subject property. Modification, alteration, or expansion of any conditional use in violation as approved per (5) above, without approval by the Plan Commission, shall be grounds for revocation of said conditional use approval per (8), above.
- (12) **Recording of Conditional Use Requirements:** Except for conditional use approvals for temporary uses, all documents associated with the written description, the approved site plan, and the specific requirements of approval, and a memorandum referring to and stating the general purpose of the conditional use (along with a legal description of the subject property), shall be recorded by the applicant with the County Register of Deeds office and submit evidence of said recordation to the City staff.
- (13) **Fee:** One or more fees are required for this procedure. Refer to Section 15.936(1)(d).
- (14) **Appeal:** If the Plan Commission denies a person's Conditional Use application, the person may appeal the decision to Sheboygan County Circuit Court under the procedures contained in Sec. 62.23(7)(e)(10), Wis. Stats."

Section 2. Subsection 15.908(1) of the City of Sheboygan Zoning Ordinance is repealed and recreated to read as follows:

"Section 15.908 Site Plan Review and Approval

(1) **Purpose:** The purpose of this Section is to specify the requirements and procedures for the review and approval of site plan applications. The provisions of this Section are designed to ensure that all proposed land use and development activity complies with the requirements of this Chapter. Specifically, this Section requires that the initiation of all development activity (including building permits, zoning certificates, occupancy permits for a change of use of an existing lot or structure where there is contemplated a site plan revision, clear cutting, grading or filling) require the approval of site, building, and operational plans by the Plan Commission before the building, occupancy, and zoning permits can be issued - except, however, that development activity associated with an approved final plat of subdivision or certified survey map for single-family and/or duplex/twin home dwelling units, development activity associated with the full and complete implementation of a project approved within the PIP phase of the Planned Unit Development District (PUD), and/or development activity associated with the full and complete implementation of a Conditional Use Permit are exempt from this requirement. Site Plan Review and Approval is not required for a change of occupancy or a change in the paved area, but is required for changes to principal or accessory structures, changes to land use, or in instances which will increase traffic or change circulation.

... ."

Section 3. All ordinances or parts thereof in conflict with the provisions of this ordinance are hereby repealed to the extent of such conflict, and this ordinance shall be in effect from and after its passage and publication.

James A. Bohrer

I HEREBY CERTIFY that the foregoing Ordinance was duly passed by the Common Council of the City of Sheboygan, Wisconsin, on the _____ day of _____, 20____.

Dated _____ 20____. _____, City Clerk

Approved _____ 20____. _____, Mayor

VI

R. C. No. _____ - 19 - 20. By LICENSING, HEARINGS, AND PUBLIC SAFETY COMMITTEE. November 18, 2019.

Your Committee to whom was referred R. O. No. 94-19-20 by City Clerk submitting various license applications; recommends denying Beverage Operator's License application No. 9148 (Christina M. Hephner) based upon her record of violations related to the licensed activity, her ineligibility for the license due to one of those conditions, and her failure to cooperate with staff for the committee.

Consent.

_____ Committee

I HEREBY CERTIFY that the foregoing Committee Report was duly accepted and adopted by the Common Council of the City of Sheboygan, Wisconsin, on the _____ day of _____, 20____.

Dated _____ 20____. _____, City Clerk

Approved _____ 20____. _____, Mayor

II

Other Matters.

R. O. No. 014 - 19 - 20. By CITY CLERK. October 21, 2019.

Submitting various license applications for the period ending June 30, 2020 and June 30, 2021.

City Clerk

BEVERAGE OPERATOR'S LICENSE (June 30, 2021) (NEW)

<u>No.</u>	<u>Name</u>	<u>Address</u>
2950	Antes, Selena A.	1323 Jefferson Avenue
2978	Doying, Samantha A.	1503 John Court
2988	Esson, Scott A.	3814 Pine View Drive
2979	Franklin, Holly N.	825 Dillingham Avenue
2983	Griffith, Carol E.	1214 S. 13 th Street
2987	Harris, Trisha M.	919 Forest Avenue
9148	Hephner, Christina M.	1610 N. 4 th Street
9513	Kaemmer, Tracey R.	1231 Huron Avenue
2986	Koene, Kayla A.	926 Erie Avenue
2981	Kimmel, Brittany A.	1731 N. 1 st Street
2980	Lindstedt-Vaughn, Allianna	2407 Calumet Drive
2982	Nichols, Kaleb A.	4782 Ridgeview Avenue
0209	Reiner, Kate E.	2419 N. 29 th Street
2663	Themer, Lorie A.	2109 N. 10 th Street
2985	Walter, Susan B.	1006 Union Avenue
2977	Ybanez, Samantha E.	3438D Eisner Court

"CLASS B" LIQUOR LICENSE (June 30, 2020) (NEW)

<u>No.</u>	<u>Name</u>	<u>Address</u>
3427	Pacifico Mexican Bar and Grill	820 Indiana Avenue

RRPS
10-30 #9148 hold
11-13 deny #9148

VI

R. C. No. _____ - 19 - 20. By LICENSING, HEARINGS, AND PUBLIC SAFETY COMMITTEE. November 18, 2019.

Your Committee to whom was referred R. O. No. 101-19-20 by Fire Chief pursuant to section 50-564 of the Municipal Code, submitting the quarterly report of Benchmark Measurements for the Fire Department, for the period commencing July 1, 2019 and ending September 30, 2019; recommends filing the document.

Consent.

_____ Committee

I HEREBY CERTIFY that the foregoing Committee Report was duly accepted and adopted by the Common Council of the City of Sheboygan, Wisconsin, on the _____ day of _____, 20____.

Dated _____ 20____. _____, City Clerk

Approved _____ 20____. _____, Mayor

3.2

R. O. No. 101 - 19 - 20. By FIRE CHIEF. November 4, 2019.

Pursuant to section 50-564 of the Municipal Code, I herewith submit my quarterly report of Benchmark Measurements for the Fire Department, for the period commencing July 1, 2019 and ending September 30, 2019.

<u>Incident Types</u>	2017 Actual	2018 YTD Figures	2018 Actual	2019 YTD Figures	2019 Goals
Fires	126	70	94	71	0
Rescue & Emergency Medical Service	3,959	3,145	4,220	3,362	3,000
Non Fires	1077	803	1055	856	800
TOTAL	5,162	4,018	5,369	4,289	
<u>Station Incident Count Per Station</u>					
Station 1	1,549	1163	1,560	1168	
Station 2	988	763	1064	803	
Station 3	1,309	1031	1,417	1115	
Station 4	814	676	818	770	
Station 5	451	355	474	408	
Out of City	51	32	36	27	
<u>Fire Loss</u>					
Number of Incidents	65	46	56	45	
Total Property Loss	\$ 276,985	\$ 579,550	\$ 630,000	\$ 340,050	
Total Content Loss	\$ 126,541	\$ 283,785	\$ 348,985	\$ 149,115	
Total Loss	\$ 403,526	\$ 863,335	\$ 978,985	\$ 489,165	
Average Loss	\$ 6,208	\$ 18,768	\$ 17,481	\$ 10,870	
<u>Workload</u>					
Inspections	1,880	1661	1,926	1860	1,800
School Safety Programs/Students	183/3353	90/1735	173/3246	119/2013	
Public Events	25	34	51	31	18
Non-Compliance/Installed Smoke Alarms	N/A	N/A	N/A	99/134	
Fire Training Hours	5,903	5962.1	7,969	5266.3	8,000
EMS Training Hours	2,697	1096.25	2,048	1656.5	1,800
Investigations/Formal	70	75	100	70	
<u>Efficiency</u>					
EMS Average Response Time (Seconds) #	N/A	N/A	N/A	88%	90%
Fire Average Response Time (Seconds) #	83%	88%	89%	88%	90%
<u>Effectiveness</u>					
Resident Satisfaction Rating	1	1	1	1	
ISO Rating	2	2	2	2	1

LAPS
file

FIRE CHIEF

VII

R. C. No. _____ - 19 - 20. By LICENSING, HEARINGS, AND PUBLIC SAFETY COMMITTEE. November 18, 2019.

Your Committee to whom was referred pursuant to R. O. No. 102-19-20 by City Clerk submitting various license applications; recommends granting the following license applications:

BEVERAGE OPERATOR'S LICENSE (NEW) (June 30, 2021)

<u>No.</u>	<u>Name</u>	<u>Address</u>
0749	Adamavich, Brooke A.	3823 S. 11 th Street
0887	Bauer, Kathleen M.	1030 Pershing Avenue
2997	Ehler, Lauren A.	2419 Calumet Drive
2102	Gonzalez, Brigitte A.	1334 Annie Court
5319	Kober, Jennifer M.	1238 Main Avenue
3002	Licari, Lori Ann	3908 State Highway 42
2990	Pierce, Jessica L.	716 Bluff Avenue
2998	Pierceall, Jeanette	916 Huron Avenue Apt. 519
1409	Schmitz, Joel P.	4001 N. 51 st Street

CHANGE OF AGENT

Mark Aschenbach is replacing Sean Webb as agent effective immediately for Pick 'N Save #432 located at 1317 N. 25th Street.

CLASS "B" BEER LICENSE (NEW) (June 30, 2020)

<u>No.</u>	<u>Name</u>	<u>Address</u>
3430	Board and Brush	528 N. 8 th Street

TAXICAB BUSINESS LICENSE (RENEW) (December 31, 2020)

<u>No.</u>	<u>Name</u>	<u>Address</u>
2997	The Best Taxi	1937 S. Business Drive

Consent.

TAXICAB DRIVERS LICENSE (NEW) (December 31, 2019)

<u>No.</u>	<u>Name</u>	<u>Address</u>
2991	Warne, Dorothy R.	2332 Carmen Avenue #2C

Committee

I HEREBY CERTIFY that the foregoing Committee Report was duly accepted and adopted by the Common Council of the City of Sheboygan, Wisconsin, on the _____ day of _____, 20____.

Dated _____ 20____. _____, City Clerk

Approved _____ 20____. _____, Mayor

VIII

R. C. No. _____ - 19 - 20. By FINANCE AND PERSONNEL COMMITTEE.
November 18, 2019.

Your Committee to whom was referred Res. No. 105-19-20 by Alderpersons Donohue and Bohren authorizing the appropriate city officials to execute an amendment to a Parking and Access Lease Agreement with Eighth Street Sheboygan Housing Corporation; recommends adopting the Resolution.

Consent.

_____ Committee

I HEREBY CERTIFY that the foregoing Committee Report was duly accepted and adopted by the Common Council of the City of Sheboygan, Wisconsin, on the _____ day of _____, 20____.

Dated _____ 20____. _____, City Clerk

Approved _____ 20____. _____, Mayor

**FIRST AMENDMENT OF
PARKING AND ACCESS LEASE AGREEMENT**

THIS FIRST AMENDMENT OF PARKING AND ACCESS LEASE AGREEMENT (the "First Amendment"), made this _____ day of _____, 2019, is by and between **EIGHTH STREET SHEBOYGAN HOUSING CORPORATION** (hereinafter referred to as "Tenant"), and the **CITY OF SHEBOYGAN, WISCONSIN**, (hereinafter referred to as "Landlord"). To the extent that the terms and conditions of this First Amendment conflict with or contradict the terms and conditions of the Parking and Access Lease Agreement to which it is attached, the terms of this First Amendment shall supersede and control.

WITNESSETH:

WHEREAS, Landlord and Tenant have entered into a Parking and Access Lease Agreement dated as of August 19, 2016, hereinafter referred to as "said Lease."

WHEREAS, Landlord and Tenant desire to further modify and amend said Lease.

NOW, THEREFORE, in consideration of mutual covenants and agreements and good and valuable consideration, the delivery and receipt of which is hereby acknowledged by and between Landlord and Tenant, the parties do hereby agree to amend said Lease as follows:

1. Sections 2.E., 3, 4, 5, 7 and 9. With respect to the number of Parking Spaces under said Lease, each reference to "forty-two", "forty two", "(42)" or "42" in Sections 2.E., 3, 4, 5, 7 and 9 is amended by deleting such reference and replacing it with "forty-one", "forty one", "(41)" or "41", respectively.
2. No Other Change. All other provisions of said Lease shall remain the same and shall continue in full force and effect.
3. Incorporation Into Lease. Landlord and Tenant agree that executed counterparts of this First Amendment shall be attached to, and become a part of, the respective copies of said Lease now in the possession of each party hereto.

IN WITNESS WHEREOF, Landlord and Tenant have duly executed this First Amendment on the day and year first above written.

**EIGHTH STREET SHEBOYGAN
HOUSING CORPORATION**

CITY OF SHEBOYGAN, WISCONSIN

Tenant

Landlord

By: _____
Michael L. Morey
President

By: _____
Michael J. Vandersteen
Mayor

Attest: _____
Meredith De Bruin
City Clerk

**FIRST AMENDMENT OF
PARKING AND ACCESS LEASE AGREEMENT**

THIS FIRST AMENDMENT OF PARKING AND ACCESS LEASE AGREEMENT (the "First Amendment"), made this 22nd day of November, 2019, is by and between **EIGHTH STREET SHEBOYGAN HOUSING CORPORATION** (hereinafter referred to as "Tenant"), and the **CITY OF SHEBOYGAN, WISCONSIN**, (hereinafter referred to as "Landlord"). To the extent that the terms and conditions of this First Amendment conflict with or contradict the terms and conditions of the Parking and Access Lease Agreement to which it is attached, the terms of this First Amendment shall supersede and control.

WITNESSETH:

WHEREAS, Landlord and Tenant have entered into a Parking and Access Lease Agreement dated as of August 19, 2016, hereinafter referred to as "said Lease."

WHEREAS, Landlord and Tenant desire to further modify and amend said Lease.

NOW, THEREFORE, in consideration of mutual covenants and agreements and good and valuable consideration, the delivery and receipt of which is hereby acknowledged by and between Landlord and Tenant, the parties do hereby agree to amend said Lease as follows:

1. Sections 2.E., 3, 4, 5, 7 and 9. With respect to the number of Parking Spaces under said Lease, each reference to "forty-two", "forty two", "(42)" or "42" in Sections 2.E., 3, 4, 5, 7 and 9 is amended by deleting such reference and replacing it with "forty-one", "forty one", "(41)" or "41", respectively.
2. No Other Change. All other provisions of said Lease shall remain the same and shall continue in full force and effect.
3. Incorporation Into Lease. Landlord and Tenant agree that executed counterparts of this First Amendment shall be attached to, and become a part of, the respective copies of said Lease now in the possession of each party hereto.

IN WITNESS WHEREOF, Landlord and Tenant have duly executed this First Amendment on the day and year first above written.

**EIGHTH STREET SHEBOYGAN
HOUSING CORPORATION**

CITY OF SHEBOYGAN, WISCONSIN

Tenant

Landlord

By: Michael L. Morey
Michael L. Morey
President

By: Michael J. Vandersteen
Michael J. Vandersteen
Mayor

Attest: Meredith De Bruin
Meredith De Bruin
City Clerk

THE UNIVERSITY OF CHICAGO

PHYSICS DEPARTMENT

PHYSICS 311

LECTURE 1

MECHANICS

1.1 Kinematics

1.2 Dynamics

1.3 Energy

1.4 Momentum

1.5 Angular Momentum

1.6 Oscillations

1.7 Relativity

PHYSICS DEPARTMENT

PHYSICS 311

LECTURE 2

MECHANICS

2.1 Kinematics

2.2 Dynamics

2.3 Energy

2.4 Momentum

2.5 Angular Momentum

2.6 Oscillations

2.7 Relativity

2.8 Quantum Mechanics

VIII

R. C. No. _____ - 19 - 20. By PUBLIC WORKS COMMITTEE. November 18, 2019.

Your Committee to whom was referred Res. No. 108-19-20 by Alderpersons Wolf and Sorenson authorizing the emergency repair of an underground electrical feeder and related equipment at the Eighth Street Draw Bridge; recommends adopting the Resolution.

Consent.

_____ Committee

I HEREBY CERTIFY that the foregoing Committee Report was duly accepted and adopted by the Common Council of the City of Sheboygan, Wisconsin, on the _____ day of _____, 20____.

Dated _____ 20____. _____, City Clerk

Approved _____ 20____. _____, Mayor

III

4.3

Res. No. 108 - 19 - 20. By Alderpersons Wolf and Sorenson.
November 4, 2019.

A RESOLUTION authorizing the emergency repair of an underground electrical feeder and related equipment at the Eighth Street Draw Bridge.

WHEREAS, there is a 1200-amp underground electrical feeder in the Eighth Street Draw Bridge, which has failed between Alliant Energy's transformer and the main electrical panel which feeds the west Hydraulic Power Unit; and

WHEREAS, failure to repair the underground electrical feeder could result in further damage to the bridge's operating system, which would render the bridge inoperable; and

WHEREAS, while the necessary work constitutes public construction, as used in Wis. Stat. § 62.15(1), that would ordinarily require taking and receiving bids, because the failure of this underground feeder endangers the public welfare, Wis. Stat. § 62.15(1b) provides that public bidding is not necessary in order to promptly address the emergency created by this failure of the electrical feeder; and

WHEREAS, City Staff anticipates that further work on the electrical system associated with the Eighth Street Draw Bridge may be necessary in the future, and anticipates that such work will be bid through the process set forth in Wis. Stat. § 62.15(1).

NOW, THEREFORE, BE IT RESOLVED: That the appropriate City officials are hereby authorized to enter into a contract with Piper Electric, Inc. in substantially similar form to that attached, for repair of the underground feeder at the Eighth Street Draw Bridge.

Public Works
adopt.

BE IT FURTHER RESOLVED: That the appropriate City officials are hereby authorized to draw funds in the amount of \$94,778.00 from Account No. 47833170-631100 (2019 Capital Improvements - Bridges - Improvements Other Than Buildings) pursuant to the contract.

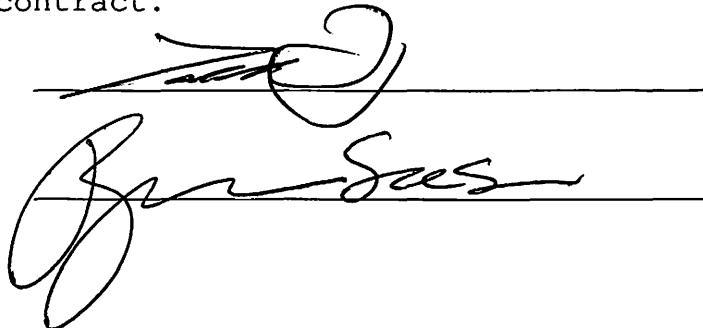

The image shows two handwritten signatures on horizontal lines. The top signature is a stylized, cursive name. The bottom signature is a more legible cursive name, possibly "John S. ...".

I HEREBY CERTIFY that the foregoing Resolution was duly passed by the Common Council of the City of Sheboygan, Wisconsin, on the _____ day of _____, 20____.

Dated _____ 20____. _____, City Clerk

Approved _____ 20____. _____, Mayor



PIEPER ELECTRIC, INC. | Solutions Powered by People Since 1947

11-01-19

City of Sheboygan
Attention: Michael Willmas
2026 New Jersey Ave.
Sheboygan, WI 53081

Re: 8th Street Bridge Repair
Estimate #: 2146-MR-211b(2)

Michael,

We will provide the labor, material, tools and supervision to provide the following:

- Remove 1200 amp underground feeders from the CT cabinet to the MCC in the bridge hydraulic room.
- Excavate roadway at bridge abutment wall.
- Repair or replace 4" rigid conduits as necessary.
- Install new 4" expansion couplings under bridge.
- Install new 600 MCM, THHN feeders. (per NEC 2017 requirements)
- Install new concrete roadway where excavated.
- Terminate and test all equipment.

Budget price for providing the above.....\$94,778.00

Proposal Notes:

- If applicable, taxes have not been included in the pricing above.
- Price includes all work already completed.
- Roadway excavation and repairs have an included allowance of \$20,000.00
- Traffic control by others.
- Any additional scope of work items beyond this proposal will incur additional costs.
- Price based on using the city's boat and operator for under bridge repairs.
- Actual work performed will be on a straight time basis.
- *Payment is to be made based on NET 30 days.*
- *If work is not completed by May 31st 2020, the remaining labor to complete this project will increase by 3%.*
- Pieper Electric, Inc. shall not be held liable for errors or omissions in designs by others, nor inadequacies of materials and equipment specified or supplied by others.
- Due to the volatility of the metals market, we reserve the right to re-quote material pricing beyond 30 days of this quote.
- Price does not include permit fee.
- Project will be invoiced at a Time and Material basis. Any pricing discussed or stated is a budgetary estimate only.

NOTE: This proposal valid for 30 days, negotiable thereafter.

We thank you for giving us the opportunity of estimating this work, and should there be any questions, please do not hesitate to contact me at 414-522-6208.

Date Accepted: _____

Sincerely,

By: _____

Mark Rautanen

Mark Rautanen
5477 South Westridge Court | New Berlin, WI 53151 | Telephone: 414-462-7700

Pieper Electric, Inc. SAFETY: **Working Together For Tomorrow**



PIEPER ELECTRIC, INC. | Solutions Powered by People Since 1947

TERMS AND CONDITIONS OF SALE

- 1. LIEN NOTICE.** As required by the Wisconsin Construction Lien Law, Seller (Pieper Electric, Inc. and all DBAs) hereby notifies Owner that persons or companies furnishing labor or materials for the construction on Owner's land may have lien rights on the Owner's land and buildings if not paid. Those entitled to lien rights, in addition to Seller, are those who contract directly with the Owner or those who give the Owner notice within sixty (60) days after they first furnish labor or materials for the construction. Accordingly, Owner will probably receive notices from those who furnish labor or materials for the construction, and should give a copy of each notice received to his mortgage lender, if any. Seller agrees to co-operate with the Owner and his lender, if any, to see that all potential lien claimants are duly paid.
- 2. ENTIRE AGREEMENT.** This Agreement constitutes the entire contract for material, work, and other goods and services (collectively "Goods") between the Seller and the buyer ordering such Goods ("Buyer"). It is expressly agreed that no statement, arrangement, warranty, or understanding, oral or written, expressed or implied, will be recognized unless it is stated in, or otherwise permitted by, this Agreement. This Agreement is solely for the benefit of Buyer and Seller, and is not intended for the benefit of any other party.
- 3. PROPOSAL.** Seller is responsible for, and shall have sole control of, the construction methods, sequences and coordination of all work described in the Proposal, unless expressly stated to the contrary. Any items not listed are not included in the Agreement price and shall be the obligation of the Buyer.
- 4. CONSTRUCTION MATERIALS.** All materials and work shall be furnished in accordance with normal industry tolerances for color, variation, thickness, size, weight, amount, finish, texture and performance standards. Excess materials delivered to job site and/or materials not physically attached to the structure after substantial completion of the work contemplated by this Agreement shall remain the property of Seller.
- 5. ACCESS TO WORK AND SITE.** Buyer shall provide electric power, water, telephone and toilet facilities for use by Seller and its subcontractors/employees. Storage of materials and storage of Seller's equipment shall also be provided by Buyer. All utility connections and service charges, if any, shall be paid by the Buyer. Furthermore, Buyer agrees to maintain access for Seller at the Project Site to keep Project Site free from obstructions and conflicting work, and to obtain permission for Seller to gain access through adjacent property, if required by Seller to do so. Buyer shall be solely responsible for all risk, shall hold Seller harmless and free of liability, and shall compensate for any damages or costs arising out of such access or the failure to maintain access, except to the extent due to the intentional acts of Seller, its agents and/or employees.
- 6. INSURANCE.** Seller shall maintain workers' compensation, automobile liability, commercial general liability and such other insurance as required by law. Seller will furnish a Certificate of Insurance evidencing the types and amounts of its coverage, upon request. Buyer shall maintain insurance covering all physical loss, expressly including, but not limited to, coverage for collapse, fire, wind damage, theft, vandalism and malicious mischief, naming Seller as additional insured. Buyer assumes risk of loss during construction, except for the intentional acts of Seller, its subcontractors or employees.
- 7. ENVIRONMENTAL HAZARDS.** Seller is not responsible for any environmental hazards. The Buyer shall be solely responsible for all risk, shall indemnify and hold Seller harmless and free of liability, and shall bear the costs of any removal or correction of environmental materials.
- 8. SITE CONDITIONS.** Seller shall not be responsible for additional costs due to the existence of latent conditions that are not disclosed in writing to Seller. The raising, disconnection, re-connection or relocation of any mechanical equipment that may be necessary for Seller to perform the work shall be performed by others or treated as an extra.
- 9. PAYMENT.** Buyer shall timely make all payments required by this Agreement. Time is of the essence as to all terms of payment. Buyer agrees that, in addition to other remedies available to Seller, if payment is not timely made, Seller shall be entitled to a service charge of 1.0% per month on all past due amounts, plus, if not contrary to any law, all costs of collection including actual attorneys' fees. Seller shall furnish lien waivers to Buyer at the time each Progress Payment and the Final Payment is made. Final Payment shall constitute acceptance and approval of all work, and a waiver of all claims by Buyer, except those arising from liens or the warranty included in this Agreement. No retention shall apply to any of the work.
- 10. JOB SIGN.** Buyer agrees to allow Seller to display a construction sign at the Project Site.
- 11. CHANGES.** No changes, additions, alterations, deviations or extras to the Plans and Specifications shall be made without a written Change Order signed by the Buyer and Seller in advance, which will be performed based on Seller's standard time and material rates. Notwithstanding, Buyer's signature shall not be required for changes necessary to conform to codes, laws or regulations required by any utility or governmental authority, or to address existing conditions of the Project Site unknown to Seller at the time Seller signs this Agreement. All Change Orders shall be incorporated as part of this Agreement. Upon Seller's request, Buyer agrees to pay for all changes in advance of each change being commenced. Buyer understands and agrees that changes will extend the time of performance by at least 5 work days for each change unless otherwise agreed in writing.
- 12. WORK STOPPAGE.** Should work be stopped by any public authority or the Buyer for more than thirty calendar days, Seller may terminate this Agreement and collect for the value of all work completed and materials ordered as of the date work is stopped, plus Seller's anticipated profit under this Agreement. Buyer's failure to sign Change Orders or Buyer's refusal to make progress payments, or any other cause beyond Seller's sole control, shall also be cause for work stoppage by Seller.
- 13. DELAY.** Work shall be completed within the number of working days stated in this Agreement, unless delay occurs due to work stoppage, adverse weather conditions, labor disputes, changes by Buyer, work performed by Buyer (or Buyer's separate contractors) or governmental authorities, unavailability of materials or supplies, unavoidable casualties, accidents, environmental hazards, Buyer's failure to make payments as required by this Agreement, or any other cause beyond Seller's sole control. Any such delay shall extend the time of performance or, at Seller's Option, terminate this Agreement if the cause of the delay cannot be resolved within thirty calendar days. Where Seller elects to extend performance, Seller shall also be entitled to additional payment to reflect any increased cost of labor and/or materials. Seller will give notice to Buyer of delay and any adjustments to time of performance or cost of the work necessitated by the delay.
- 14. DISPUTES.** These Terms shall be deemed to have been made in and governed by the laws of the State of Wisconsin. Any legal suit or action with regard to these Terms or the Project hereunder may, at Seller's option, be venue in Milwaukee County Circuit Court, Wisconsin. Seller may also, at Seller's sole discretion, elect arbitration and/or mediation in place of civil litigation, without regard to whether litigation has been commenced by Buyer. If an Arbitrator cannot be agreed upon, Seller can petition Circuit Court for same.
- 15. WARRANTY.** Seller warrants and guarantees to Buyer that all material and equipment, and the work to be performed hereunder, will be of good quality and free from faults and defects. This warranty shall cover material (except lamps and other expendables) for the manufacturer's stated warranty period and workmanship for one year from the date of substantial completion. This warranty does not apply to bid work. If the bid documents stipulate a lesser warranty, this warranty is in lieu of all other warranties, express or implied, of merchantability, fitness for a particular purpose, performance, or otherwise. Seller's liability under the warranty is strictly and exclusively limited to the repair or replacement at the job site of such work (including material and equipment) as is found to be defective within such warranty period, and with respect to which the Buyer has given Seller prompt written notice within such period. No allowance will be made for repairs or alterations unless made with Seller's prior written consent or approval. In no event shall Seller be liable for claims for any other damages based upon breach of express or implied warranty or negligence whether direct, immediate, foreseeable, consequential or special. This paragraph states Seller's entire liability with respect to warranties, guarantees, or representations, express or implied. Seller will be held harmless against claims, damages, losses and expenses, including attorneys' fees arising from work not done by Seller's own workforce.
- 16. CONFLICTS/INCONSISTENCIES.** If any inconsistency or ambiguity is believed to exist among any of the documents comprising the contract, the inconsistency or ambiguity shall be resolved by applying the following order of precedence: (a) this Agreement including these Terms and Conditions; (b) the plans and specifications, if any; (c) other documents comprising the contract, if any.
- 17. ASBESTOS AND TOXIC MATERIALS.** This proposal and contract is based upon the work to be performed by Seller not involving asbestos-containing or toxic materials and that such materials will not be encountered or disturbed during the course of performing the work. Seller is not responsible for expenses, claims or damages arising out of the presence, disturbance, or removal of asbestos-containing or toxic material in the event that such materials are encountered. Seller shall be entitled to reasonable compensation for all additional expenses incurred as a result of the presence of asbestos-containing or toxic materials at the work site.
- 18. PROTECTION OF PERSONAL PROPERTY AND PROJECT SITE.** Buyer agrees to remove or protect any personal property inside and outside the Project Site. Seller shall make reasonable efforts to avoid damage to existing property. Seller will make every effort to keep dust down to a bare minimum. Seller is not responsible for housecleaning or damages during normal construction activities.
- 19. IMPAIRMENT OF CREDIT.** If Buyer is or becomes insolvent, or is unable to pay his debts as they mature, or files or has filed against him a bankruptcy, insolvency, or similar petition or fails to pay any debt arising hereunder to Seller on time, or if Seller in good faith doubts the ability of Buyer to pay, Seller may, at its option, either: (a) terminate the work at any time thereafter, and Buyer shall thereupon pay for all work performed on a pro-rata basis plus all lost profit or (b) discontinue work until such time as the Buyer has paid Seller in full for work performed, has agreed to pay Seller for any additional costs incurred because of such discontinuance, and upon such other terms or conditions as may be imposed by Seller to ensure the payment for the work.
- 20. HOLD HARMLESS.** Seller will hold harmless and defend Buyer against any claims brought by a third party for damages or losses arising out of Seller's performance of work under this contract provided that the third party claim is attributable to bodily injury or death, or injury to or from destruction of tangible property, but only to the extent caused by the negligence of Seller or Seller's subcontractors and not caused in whole or in part by the Buyer or its agents, employees or representatives. Seller shall not be liable for any consequential damages claimed by any party including, but not limited to, lost profits, loss of use, or attorney's fees. As conditions precedent to Seller's duties under this provision, Buyer must (a) provide Seller with written notice of any claim against Buyer immediately after Buyer is aware of the claim; and (b) remain current with all of Buyer's obligations under this contract. This provision is null and void if the Buyer fails to perform any of its obligations under this contract. Seller shall have the sole right to manage the defense of the claim or resolve the claim. Buyer agrees to fully cooperate with Seller in the investigation and defense of any claim brought by another party.
- 21. WORKING HOURS.** Unless specifically noted, all work included in this contract is to be performed during normal business hours, Monday through Friday. Work performed at any other time, or on legal holidays, will result in an extra charge to Buyer.
- 22. GENERAL EXCLUSIONS.** Seller shall not be responsible for coordinating or supervising work performed by Buyer's own forces or contractors. Seller shall be entitled to an equitable adjustment for hidden or latent conditions. Cost of pumping water from basements and other excavations is not included in quotation. Any alteration or deviation from the specifications as outlined on reverse involving extra cost of material or labor will only be executed upon written orders for same and will become an extra charge over the sum mentioned in this contract. Seller is not responsible for damage to underground services. Any changes in local or state codes effective after date of proposal will be charged as an extra or credited as the case may be. Patching of walls and floors is to be done by others unless specifically stated in this contract as Seller's responsibility.

5477 South Westridge Court | New Berlin, WI 53151 | Telephone: 414-462-7700

SAFETY: Working Together For Tomorrow

II

R. O. No. _____ - 19 - 20. By CITY CLERK. November 18, 2019.

Submitting a claim from Kevin Delray for alleged damages to his vehicle when the tire hit a large section of raised concrete concealed by rain.

Financeet
Personnel

CITY CLERK

DATE RECEIVED 11/1/19

RECEIVED BY JW

CLAIM NO. 19-19

CITY OF SHEBOYGAN NOTICE OF DAMAGE OR INJURY

INSTRUCTIONS: TYPE OR PRINT IN BLACK INK

- 1. Notice of death, injury to persons or to property must be filed not later than 120 days after the occurrence.
- 2. Attach and sign additional supportive sheets, if necessary.
- 3. This notice form must be signed and filed with the Office of the City Clerk.

4. TWO ESTIMATES MUST BE ATTACHED IF YOU ARE CLAIMING DAMAGE TO A VEHICLE.

1. Name of Claimant: Kevin Delray

2. Home address of Claimant: 1717 Pheasant Ln., Sheboygan, WI 53081

3. Home phone number: 920-627-3446

4. Business address and phone number of Claimant: _____

5. When did damage or injury occur? (date, time of day) 9/22/19 7:00 pm

6. Where did damage or injury occur? (give full description) Median Strip North of Wilson Ave. on Bus. 42 (directly in front of pizza Hut).

7. How did damage or injury occur? (give full description) Tire hit concealed (by rain) large section of raised concrete.

8. If the basis of liability is alleged to be an act or omission of a City officer or employee, complete the following:

(a) Name of such officer or employee, if known: _____

(b) Claimant's statement of the basis of such liability: _____

9. If the basis of liability is alleged to be a dangerous condition of public property, complete the following:

(a) Public property alleged to be dangerous: _____

(b) Claimant's statement of basis for such liability: _____

10. Give a description of the injury, property damage or loss, so far as is known at this time. (If there were no injuries, state "NO INJURIES").

No injuries to person. Wheel damaged on car; fire blowout.

11. Name and address of any other person injured: N/A

12. Damage estimate: (You are not bound by the amounts provided here.)

Auto: \$ 600 wheel + 109.06 for tire (already pd.)

Property: \$

Personal injury: \$

Other: (Specify below) \$

TOTAL \$ 709.06

Damaged vehicle (if applicable)

Make: Toyota Model: Camry Year: 2018 Mileage: 19,800

Names and addresses of witnesses, doctors and hospitals: N/A

FOR ALL ACCIDENT NOTICES, COMPLETE THE FOLLOWING DIAGRAM IN DETAIL. BE SURE TO INCLUDE NAMES OF ALL STREETS, HOUSE NUMBERS, LOCATION OF VEHICLES, INDICATING WHICH IS CITY VEHICLE (IF APPLICABLE), WHICH IS CLAIMANT VEHICLE, LOCATION OF INDIVIDUALS, ETC.

NOTE: If diagrams below do not fit the situation, attach proper diagram and sign.

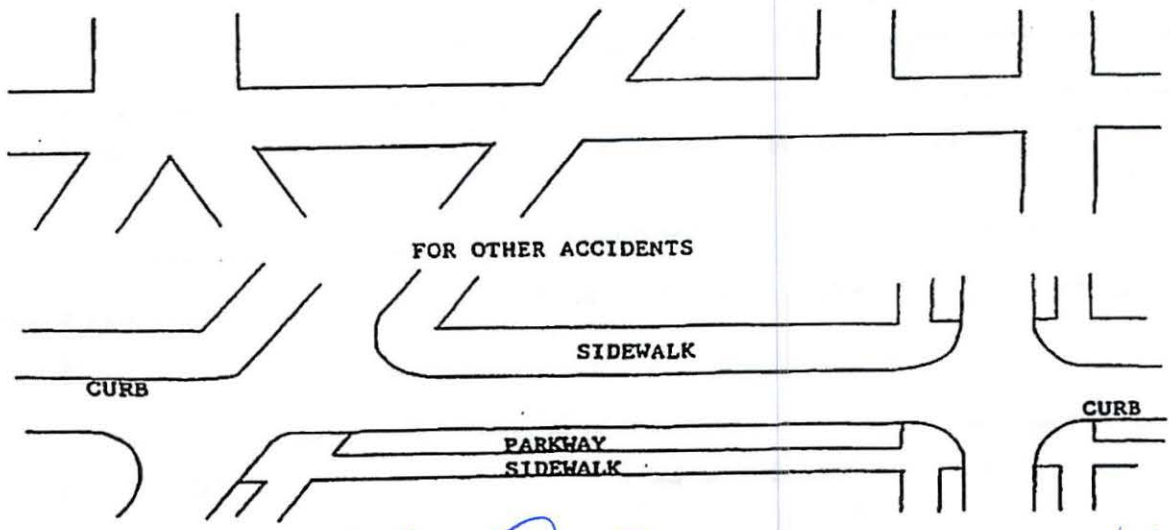

SIGNATURE OF CLAIMANT Kelley DATE 11/1/19

NOV 1 '19 PM 12:12

DATE RECEIVED _____

RECEIVED BY _____

CLAIM NO. _____

CLAIM

Claimant's Name: Kevin Deloy
 Claimant's Address: 1717 Pleasant Ln.
Sheboygan, WI 53081
 Claimant's Phone No. 920-627-3446

Auto \$ 709.⁰⁶
 Property \$ _____
 Personal Injury \$ _____
 Other (Specify below) \$ _____
TOTAL \$ 709.⁰⁶

PLEASE INCLUDE COPIES OF ALL BILLS, INVOICES, ESTIMATES, ETC.

WARNING: IT IS A CRIMINAL OFFENSE TO FILE A FALSE CLAIM.
(WISCONSIN STATUTES 943.395)

The undersigned hereby makes a claim against the City of Sheboygan arising out of the circumstances described in the Notice of Damage or Injury. The claim is for relief in the form of money damages in the total amount of \$ 709.⁰⁶.

SIGNED  DATE: 11/1/19

ADDRESS: 1717 Pleasant Ln. Sheboygan, WI 53081

MAIL TO: CLERK'S OFFICE
 828 CENTER AVE #100
 SHEBOYGAN WI 53081





INTERNATIONAL TOYOTA SCION SUBARU

4120 N. FRONTAGE RD
SHEBOYGAN, WI 53081
920-208-0200
FAX: 920-694-3880

CELL: 920-627-3446

Table with 8 columns: CUST NO., TAX EXEMPT NUMBER, CUST. P. O. NO., SHIP VIA, PAY, SOLD BY, INVOICE DATE, INVOICE NO. Values include 41690, 414-760-8455, CASH, MATTHEW BENAVIDE, 10/15/19, PQ14368 TOR.

TOYOTA | SCION | SUBARU | HONDA
B I L L T O kevin.delray1@gmail.com
KEVIN DELRAY
1717 PHEASANT LN
SHEBOYGAN, WI 53081

S H I P

Main invoice table with columns: SHIP QTY, B. O. QTY, PART NUMBER / DESCRIPTION, BIN, LIST, NET, AMOUNT. Row 1: 1, 0, 42611-06E20 WHEEL, DISC, XX, 604.61, 604.61, 604.61. Includes subtotal, restock charge, tax, and freight amounts.

DISCLAIMER OF WARRANTIES
Any warranties on the product sold hereby are those made by the manufacturer. The seller hereby expressly disclaims all warranties, either express or implied, including any implied warranty of merchantability or fitness for a particular purpose...

All claims and returned goods must be accompanied by this invoice. No returns after 7 days. All returned mdse. subject to 20% handling charge. No returns on electrical or special order items.

THANK YOU

*PARTS DEPT. HOURS
Monday - Friday
7:00 AM - 6:00 PM
Saturday
8:00 AM - 2:00 PM
Closed Sundays

** PRICE QUOTE **
12:33:18 PAGE 1 OF 1
NET505

CUSTOMER COPY

PARTS INVOICE

LEGAL COUNSEL

INTERNATIONAL TOYOTA SUB
4120 N FRONTAGE RD
SHEBOYGAN, WI 53081
(920) 208-0200

INTERNATIONAL TOYOTA SCION SUBARU

4120 N. FRONTAGE RD
SHEBOYGAN, WI 53081
920-208-0200
FAX: 920-694-3880

\$ 109.⁰⁶
per fix

SALE

NDA

MID: 520002451751
TID: 005 REF#: 00003965
Batch #: 269001 RRN: 520100001
09/26/19 07:43:44
APPR CODE: 69349D
VISA Chip
*****7628 **/**

AMOUNT \$436.25

APPROVED

ADVISOR JAMES TRUMAN	TAG NO. 2044 011	INVOICE DATE 09/25/19	INVOICE NO. TOCS318497
LICENSE NO.	MILEAGE 19,804	COLOR	STOCK NO. JU053048
YEAR / MAKE / MODEL 18/TOYOTA/CAMRY/4DR SDN I4 XSE AT	DELIVERY DATE 03/23/18	DELIVERY MILES 229	PRODUCTION DATE
VEHICLE I.D. NO. 4 T 1 B 6 1 H K 4 J U 0 5 3 0 4 8	CELL PHONE 760-8455	P. O. NO.	R. O. DATE 09/24/19
PHONE 760-8455	SERVICE CONTRACT		MO: 19804

VISA CREDIT
AID: A0000000031010
TVR: 80 80 00 80 00
TS: 68 00

WARRANTY
ARE SYN TECH(S):2025 313
TOYOTA EXTRA CARE SERVICE SYNTHETIC.
ENGINE OIL AND FILTER, TIRE ROTATION, AND
INSPECTION.
MILE TOYOTA EXTRA CARE SYNTHETIC SERVICE.
CUSTOMER COPY FILTER, ROTATED TIRES, AND PERFORMED
POINT INSPECTION.

PARTS	QTY	FP-NUMBER	DESCRIPTION	LIST PRICE	UNIT PRICE	PRICE
	1	PKM1	OIL CHANGE			WARRANTY
	1	90430-12031	GASKET			WARRANTY
	1	90915-YZZM1	FILTER, OIL			WARRANTY
	5	00279-16QTE-01	OW16 6X1 QT/CASE-			WARRANTY
TOTAL - PARTS						0.00

JOB# 1 TOTALS-----
JOB# 1 JOURNAL PREFIX TOCS JOB# 1 TOTAL 0.00

JOB# 2 CHARGES-----

LABOR-----
J# 2 01TOZVI MULTIPOINT INSPECT. TECH(S):313 WARRANTY
PERFORM WORLD CLASS MULTIPPOINT INSPECTION
PERFORMED WORLD CLASS MULTIPOINT INSPECTION. SEE VEHICLE
HEALTH REPORT ATTACHED.

JOB# 2 TOTALS-----
JOB# 2 JOURNAL PREFIX TOCS JOB# 2 TOTAL 0.00

JOB# 3 CHARGES-----

LABOR-----
J# 3 46TOZMB4 MNT & BLNC 4 TIRES TECH(S):313 89.99
C/S: 4 NEW TIRES- SEE JIM
4 MICHELIN PRIMACY MXM4 235/40/R19--GOOD WILL PER MICHELIN
MICHELIN COVERING 65% OF TIRES ONLY ON LABOR
MOUNT AND BALANCED FOUR TIRES

PARTS	QTY	FP-NUMBER	DESCRIPTION	LIST PRICE	UNIT PRICE	PRICE
	4	DT000-13134-MI	235/40R19	241.35	80.88	323.52
TOTAL - PARTS						323.52

JOB# 3 TOTALS-----
LABOR 89.99
PARTS 323.52

JOB# 3 JOURNAL PREFIX TOCS JOB# 3 TOTAL 413.51

JOB# 4 CHARGES-----

LABOR-----
J# 4+46TOZ WHEELS/TIRES TECH(S):313 WARRANTY
MICHELIN PORTION OF GOODWILL WARRANTY

Thank you Kevin!
Jim Truman

"Motor vehicle repair practices are regulated by Chapter ATCP 132, Wis. Adm. Code, administered by the Bureau of Consumer Protection, Wisconsin Dept. of Agriculture, Trade and Consumer Protection, P.O. Box 8911, Madison, Wisconsin 53708-8911."

The Reynolds and Reynolds Company EHAINTS14E CC723417 Q (10/14)



INTERNATIONAL TOYOTA SCION SUBARU

4120 N. FRONTAGE RD
SHEBOYGAN, WI 53081
920-208-0200
FAX: 920-694-3880

TOYOTA | SCION | SUBARU | HONDA

CELL: 920-627-3446

NO. 41690	ADVISOR JAMES TRUMAN	TAG NO. 2044	011	INVOICE DATE 09/25/19	INVOICE NO. TOCS318497
IN DELRAY	LICENSE NO.	MILEAGE 19,804	/	COLOR	STOCK NO. JU053048
PHEASANT LN	YEAR / MAKE / MODEL 18/TOYOTA/CAMRY/4DR SDN I4 XSE AT	DELIVERY DATE 03/23/18		DELIVERY MILES 229	
COYGAN, WI 53081	VEHICLE I.D. NO. 4 T 1 B 6 1 H K 4 J U 0 5 ' 3 0 4 8			PRODUCTION DATE	
EMAIL delray1@gmail.com	CELL PHONE	P.O. NO.		R.O. DATE 09/24/19	
PHONE	BUSINESS PHONE 414-760-8455	SERVICE CONTRACT			

MO: 19804

QTY	FP-NUMBER	DESCRIPTION	LIST PRICE	UNIT PRICE	WARRANTY
4	DT000-13134-MI	235/40R19			0.00
TOTAL - PARTS					0.00
JOB# 4 JOURNAL PREFIX TOCS JOB# 4 TOTAL					0.00

 I HEREBY ACKNOWLEDGES RECEIVING
 ORIGINAL ESTIMATE OF \$500.00 (+TAX)

 I REQUESTED A LOANER created 2019-09-12 10:40:00am taken by
 a Serna

*****		TOTAL LABOR....	89.99
CASH [] CHECK CK NO. []		TOTAL PARTS....	323.52
VISA [] MASTERCARD [] DISCOVER		TOTAL SUBLET...	0.00
AMER XPRESS [] OTHER [] CHARGE		TOTAL G.O.G....	0.00
*****		TOTAL MISC CHG.	0.00
		TOTAL MISC DISC	0.00
		TOTAL TAX.....	22.74
		TOTAL INVOICE \$	436.25

THANK YOU FOR YOUR BUSINESS!!

CUSTOMER SIGNATURE

TOYOTA | SCION | SUBARU | HONDA

"Motor vehicle repair practices are regulated by Chapter ATCP 132, Wis. Adm. Code, administered by the Bureau of Consumer Protection, Wisconsin Dept. of Agriculture, Trade and Consumer Protection, P.O. Box 8911, Madison, Wisconsin 53708-8911."

THE PRINTER MAKES NO WARRANTY, EXPRESS OR IMPLIED, AS TO CONTENT OR FITNESS FOR PURPOSE OF THIS FORM. CONSULT YOUR OWN LEGAL COUNSEL.



EXPRESS MAINTENANCE

(920) 208-0200



SUBARU



TOYOTA

Multipoint Inspection

CUSTOMER AND VEHICLE INFORMATION

Date 9/25/19

Customer Name: Dellray

Today's Contact Phone #: _____

Year/Make/Model: 2018 Camry

Mileage: 19804

VIN

										J	U	0	5	3	0	4	8
--	--	--	--	--	--	--	--	--	--	---	---	---	---	---	---	---	---

VEHICLE CONDITION

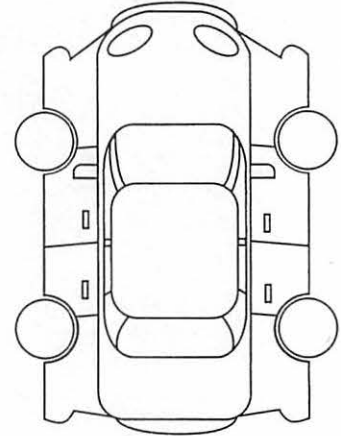

Exterior	<input checked="" type="checkbox"/>	Horn operation
	<input checked="" type="checkbox"/>	Head lights / tail lights / turn signals / brake lights / hazard warning lights / exterior lamps
	<input checked="" type="checkbox"/>	Windshield wiper and washer operation
	<input checked="" type="checkbox"/>	Windshield glass
	<input checked="" type="checkbox"/>	Fuel tank cap gasket

Interior	<input checked="" type="checkbox"/>	Dome light / amp light / dimmer combination meter
	<input checked="" type="checkbox"/>	Cabin air filter
	<input checked="" type="checkbox"/>	Parking brake operation
	<input checked="" type="checkbox"/>	Check installation of driver's floor mat

Under Hood	<input checked="" type="checkbox"/>	Air filter
	<input checked="" type="checkbox"/>	Battery condition (cables / clamps / corrosion)
	<input checked="" type="checkbox"/>	Battery state of health
	<input checked="" type="checkbox"/>	Cooling system (leaks)
	<input checked="" type="checkbox"/>	Hoses (cracks / damage / leaks)
	<input checked="" type="checkbox"/>	Drive belts (cracks / damage / wear)
<input checked="" type="checkbox"/>	Radiator core / air condition condenser (if equipped)	

Fluids	<input checked="" type="checkbox"/>	OK Filled (Oil level on arrival)
	<input checked="" type="checkbox"/>	Windshield Washer
	<input checked="" type="checkbox"/>	Coolant (____ degree of protection)
	<input checked="" type="checkbox"/>	Power steering (if equipped)
	<input checked="" type="checkbox"/>	Brake reservoir
	<input checked="" type="checkbox"/>	Clutch reservoir (if equipped)
	<input checked="" type="checkbox"/>	Transmission / transaxle
	<input checked="" type="checkbox"/>	Differential (if equipped)
	<input checked="" type="checkbox"/>	Transfer case (4WD models)

Under Vehicle	<input checked="" type="checkbox"/>	Propeller / driveshaft (damage / leaks / U-joints)
	<input checked="" type="checkbox"/>	Drive / CV shaft (damage / leaks / boots)
	<input checked="" type="checkbox"/>	Axle hub & bearing (damage / leaks / noise)
	<input checked="" type="checkbox"/>	Steering linkage (damage / leaks / worn components)
	<input checked="" type="checkbox"/>	Suspension (damage / leaks / worn components)
	<input checked="" type="checkbox"/>	Fluid leaks (engine / transmission / differential)
	<input checked="" type="checkbox"/>	Exhaust system (damage / leaks / corrosion)
	<input checked="" type="checkbox"/>	Fuel lines & connections / fuel tank bands / fuel tank vapor vent system hoses (damage / leaks / corrosion)

All New Today

LF _____ RF _____ LR _____ RR _____

Spare _____ / _____ Spare not checked/adjusted

Tread depth:

LF _____/32 RF _____/32 LR _____/32 RR _____/32

Tire damage / abnormal wear:

LF _____ RF _____ LR _____ RR _____ Spare _____

Rims / wheels / lug nuts:

LF _____ RF _____ LR _____ RR _____

Tires Rotated _____ Torque Spec: _____

Brake lining:

LF _____ mm RF _____ mm LR _____ mm RR _____ mm

Brake lines / hoses / parking brake cable

Discs / drums / callipers / wheel cylinders

Comments _____

Technician Team: _____

Checked and OK at this time May require future attention requires immediate attention



RUSS DARROW TOYOTA
 2700 W. WASHINGTON AVENUE
 WEST BEND, WISCONSIN 53095
 (262) 334-9411 · www.russdarrow.com

PARTS DIRECT (262) 338-5811
 NATIONWIDE 1-800-253-1264

DISCLAIMER OF WARRANTIES
 The dealer is not a party to any Manufacturer's warranty on parts or service contained herein. THE SELLER HEREBY EXPRESSLY DISCLAIMS ALL WARRANTIES, EITHER EXPRESS OR IMPLIED, INCLUDING ALL IMPLIED WARRANTIES OF MERCHANTABILITY OR FITNESS FOR THE PARTICULAR PURPOSE, AND NEITHER ASSUMES NOR AUTHORIZES ANY OTHER PERSON TO ASSUME FOR IT ANY LIABILITY IN CONNECTION WITH THE SALE OF THESE PARTS.

NO REFUNDS WITHOUT THIS INVOICE. NO REFUNDS AFTER 10 DAYS. NO REFUNDS OR RETURNS ON ELECTRICAL OR SPECIAL ORDER ITEMS. ALL PARTS SUBJECT TO 20% HANDLING.

DATE ENTERED 01 NOV 19	YOUR ORDER NO.	DATE SHIPPED 01 NOV 19	INVOICE DATE	INVOICE NUMBER 044163
---------------------------	----------------	---------------------------	--------------	--------------------------

ACCOUNT NO. 10 ***** INVOICE QUOTE - DO NOT PAY ***** PAGE 1 OF 1

SOLD TO

KEVIN DELRAY

SHIP TO

SHIP VIA	SLSM. 745	B/L NO.	TERMS CASH	F.O.B. WEST BEND, WI
----------	--------------	---------	---------------	-------------------------

ORD	SHIP	B.O	PART NUMBER	DESCRIPTION	LIST	NET	AMOUNT
1	1	0	42611-06E20	SOPWHEEL, DIS	604.61	604.61	604.61
***** INVOICE QUOTE - DO NOT PAY *****							

THANK YOU!
PARTS DEPT. HOURS

 Mon - Fri
 7:00 am - 6:00 pm

 Saturday
 7:00 am - 5:00 pm

ALL RETURNS WITHIN 21 DAYS OF SALE
 NO RETURNS ON SPECIAL ORDER PARTS
 NO RETURNS ON ELECTRICAL ITEMS
 FAX DIRECT @ 262-306-4120
 PARTS DIRECT @ 262-338-5811

PARTS	604.61
DISCOUNT	
FREIGHT	0.00
SALES TAX	33.86
TOTAL	\$638.47

SEE OUR BOUTIQUE AND ACCESSORY CENTER.

THANK YOU! CUSTOMER COPY



RUSS DARROW TOYOTA
 2700 W. WASHINGTON AVENUE
 WEST BEND, WISCONSIN 53095
 (262) 334-9411 · www.russdarrow.com

PARTS DIRECT (262) 338-5811
 NATIONWIDE 1-800-253-1264

DISCLAIMER OF WARRANTIES
 The dealer is not a party to any Manufacturer's warranty on parts or service contained herein. THE SELLER HEREBY EXPRESSLY DISCLAIMS ALL WARRANTIES, EITHER EXPRESS OR IMPLIED, INCLUDING ALL IMPLIED WARRANTIES OF MERCHANTABILITY OR FITNESS FOR THE PARTICULAR PURPOSE, AND NEITHER ASSUMES NOR AUTHORIZES ANY OTHER PERSON TO ASSUME FOR IT ANY LIABILITY IN CONNECTION WITH THE SALE OF THESE PARTS.

NO REFUNDS WITHOUT THIS INVOICE. NO REFUNDS AFTER 10 DAYS. NO REFUNDS OR RETURNS ON ELECTRICAL OR SPECIAL ORDER ITEMS. ALL PARTS SUBJECT TO 20% HANDLING.

DATE ENTERED 01 NOV 19	YOUR ORDER NO.	DATE SHIPPED 01 NOV 19	INVOICE DATE	INVOICE NUMBER 044163
---------------------------	----------------	---------------------------	--------------	--------------------------

ACCOUNT NO. 10 ***** INVOICE QUOTE - DO NOT PAY ***** PAGE 1 OF 1

SOLD TO

KEVIN DELRAY

SHIP TO

SHIP VIA	SLSM. 745	B/L NO.	TERMS CASH	F.O.B. WEST BEND, WI
----------	--------------	---------	---------------	-------------------------

ORD	SHIP	B.O	PART NUMBER	DESCRIPTION	LIST	NET	AMOUNT
1	1	0	42611-06E20	SOPWHEEL, DIS	604.61	604.61	604.61
***** INVOICE QUOTE - DO NOT PAY *****							

ALL RETURNS WITHIN 21 DAYS OF SALE
 NO RETURNS ON SPECIAL ORDER PARTS
 NO RETURNS ON ELECTRICAL ITEMS
 FAX DIRECT @ 262-306-4120
 PARTS DIRECT @ 262-338-5811

PARTS	604.61
DISCOUNT	
FREIGHT	0.00
SALES TAX	33.86
TOTAL	\$638.47

THANK YOU!

Call ID: #60576
 Date: 09/22/2019
 Club: 270

Printed on: 10/07/2019
 Archive Call: Yes
 D3 User: WH14D3

Membership Information	
Membership: 4382705842097036 Membership Status: A Expires: 08/01/2020 Level: Basic Cancellation Date:	Contact Name: KEVIN DELRAY Member Name: KEVIN DELRAY Address: 1710 CARMEN AVE City: SHEBOYGAN State: WI Zip: Phone: (920) 627-3446 Member Since: 07

Breakdown Information	
Breakdown Location: 3004 S 18TH STREET WILSON AVENUE City: SHEBOYGAN State: WI Phone: Type: Trouble Code(s): T1 Policy: Pacesetter Code(s): L101 Priority Code: PTA: 09/22/2019 20:31:00 CDT Landmark/Directions: /VEH NEAR ADDRESS // FLAT WITH SPARE	

Vehicle Information	
Year: 18 Model: CAMRY Type: PS Tag:	Make: TOYOTA Color: Gray Pass: 0

Callback Information	
Callback: Minutes: 10	Type: MC

Facility Information	
Spotted to: WH14 Driver: 237599 Truck: 33	Region: Phone:

Tow Destination
Tow Destination:

Duplicate Calls

Call History			
09/22/2019	RE-	HE69601	CR
19:51:59 CDT	D3		
09/22/2019	SP-	HE69601	CR WH14
19:51:59 CDT	XU		
09/22/2019		HE69601	PHOTO ID AVAILABLE
19:51:59 CDT			
09/22/2019		HE69601	Triage selection: L101 Flat Tire w/spare - PS rear - Mbr unsure if veh has locking lug nuts
19:51:59 CDT			
09/22/2019		HE69601	Mbr Advised Safe
19:51:59 CDT			
09/22/2019		HE69601	pta 8:35pm
19:51:59 CDT			
09/22/2019		HE69601	Leaving Call
19:51:59 CDT			
09/22/2019	S1-	COMM_MGR AD	WH14
19:52:02 CDT	GT		
09/22/2019		SMS	AAASERVICE: Alert We have rec'd your service request #60576 Msg freq depends on user.Msg&Data Rates May Apply, Reply STOP to cancel txts. HELP for help w/txt.
19:52:02 CDT			
09/22/2019	DI	WH14	DI WH14/33
19:53:53 CDT			
09/22/2019	AS	WH14/33	TR WH14/33
19:53:53 CDT			
09/22/2019	BD	WH14/33	TR WH14/33
19:53:53 CDT			
09/22/2019	CO	WH14	TR WH14/33
19:54:01 CDT			
09/22/2019	ER	WH14/33	TR WH14/33
19:54:01 CDT			
09/22/2019	ET	WH14/33	TR WH14/33
19:54:01 CDT	-		
09/22/2019	S1-	COMM_MGR AD	WH14/33
19:54:17 CDT	IN		
09/22/2019		SMS	AAASERVICE: Service will arrive by 08:34 PM. Ref# 60576. Download our app to track your service: AAA.com/mobile .Reply STOP to cancel txts. HELP for help w/txt
19:54:17 CDT			
09/22/2019	OL	WH14/33	TR WH14/33
19:54:17 CDT			

II

R. O. No. _____ - 19 - 20. By CITY CLERK. November 18, 2019.

Submitting a notice of claim from Mel Arentsen for alleged damages to his yard due to erosion from South Pointe Campus.

Finance +
Personnel

CITY CLERK

DATE RECEIVED

11-8-19

RECEIVED BY

NOV 8 '19 PM 2:35

CLAIM NO.

20-19

CITY OF SHEBOYGAN NOTICE OF DAMAGE OR INJURY

INSTRUCTIONS: TYPE OR PRINT IN BLACK INK

- 1. Notice of death, injury to persons or to property must be filed not later than 120 days after the occurrence.
- 2. Attach and sign additional supportive sheets, if necessary.
- 3. This notice form must be signed and filed with the Office of the City Clerk.

4. TWO ESTIMATES MUST BE ATTACHED IF YOU ARE CLAIMING DAMAGE TO A VEHICLE.

- 1. Name of Claimant: MEL ARENTLEW
- 2. Home address of Claimant: 2709 PRAIRIE WINDS CT. SHEBOYGAN
- 3. Home phone number: 920 918 7872
- 4. Business address and phone number of Claimant: SAME

5. When did damage or injury occur? (date, time of day) ON GOING FROM AUG 2018

6. Where did damage or injury occur? (give full description) EROSION FROM SOUTH POINT CONTRACT HAS BEEN DEPOSITED IN MY YARD

7. How did damage or injury occur? (give full description) WATER RUN OFF FROM SOUTH POINT CONTRACT CAUSED CLAY INTO MY YARD & TILE SYSTEM

8. If the basis of liability is alleged to be an act or omission of a City officer or employee, complete the following:

(a) Name of such officer or employee, if known: LACK OF OVERSIGHT FROM ? CITY ENG DEPT

(b) Claimant's statement of the basis of such liability: _____

9. If the basis of liability is alleged to be a dangerous condition of public property, complete the following:

(a) Public property alleged to be dangerous: LACK OF EROSION CONTRACT

(b) Claimant's statement of basis for such liability: CITY NEEDS TO MAKE SURE EROSION CONTRACT IS IN PLACE & OF THE PROPER TYPE. CITY NEEDS TO MAINTAIN THESE CONTRACTS & CHECK THEM AFTER RAIN & SNOW EVENTS

20. Give a description of the injury, property damage or loss, so far as is known at this time. (If there were no injuries, state "NO INJURIES").

YARD HAS CLAY DEPOSIT IN 15 FILLID DRAIN TILE

11. Name and address of any other person injured: NEIGHBORS MAY BE

AFFECTED ALSO

12. Damage estimate: (You are not bound by the amounts provided here.)

Auto: \$ _____

Property: \$ _____

Personal injury: \$ _____

Other: (Specify below) \$ 10,000? COST TO REPAIR TO BE

TOTAL \$ DETERMINED WHEN EROSION HAS STOPPED

Damaged vehicle (if applicable)

N.A.

Make: _____ Model: _____ Year: _____ Mileage: _____

Names and addresses of witnesses, doctors and hospitals: _____

FOR ALL ACCIDENT NOTICES, COMPLETE THE FOLLOWING DIAGRAM IN DETAIL. BE SURE TO INCLUDE NAMES OF ALL STREETS, HOUSE NUMBERS, LOCATION OF VEHICLES, INDICATING WHICH IS CITY VEHICLE (IF APPLICABLE), WHICH IS CLAIMANT VEHICLE, LOCATION OF INDIVIDUALS, ETC.

NOTE: If diagrams below do not fit the situation, attach proper diagram and sign.

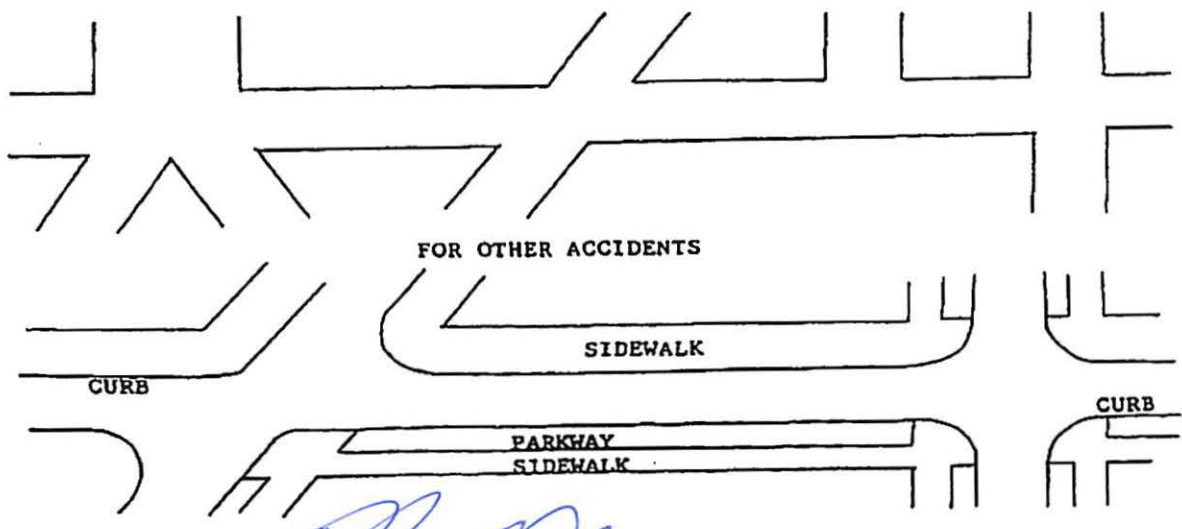

SIGNATURE OF CLAIMANT [Signature] DATE 11-7-19

DATE RECEIVED

11-8-19

RECEIVED BY

MYLC

CLAIM NO.

20-19

CLAIM

Claimant's Name:

Mr. Anderson

Auto

\$

Claimant's Address:

2709 Prairie Winds Ct

Property

\$

Sheboygan WI

Personal Injury

\$

Claimant's Phone No.

920 918 7872

Other (Specify below)

\$

TOTAL

\$10,000

PENDING AMOUNT OF DAMAGE

PLEASE INCLUDE COPIES OF ALL BILLS, INVOICES, ESTIMATES, ETC.

WARNING: IT IS A CRIMINAL OFFENSE TO FILE A FALSE CLAIM. (WISCONSIN STATUTES 943.395)

The undersigned hereby makes a claim against the City of Sheboygan arising out of the circumstances described in the Notice of Damage or Injury. The claim is for relief in the form of money damages in the total amount of \$ 10,000. ? OR ACTUAL RECEIPTS.

AMOUNT OF WORK & ASSOCIATED COST WILL BE DETERMINED WHEN BRAYSON PAVING HAS STOPPED. CITY TO VERIFY THEY MEET DNR REQUIREMENTS

SIGNED

[Signature]

DATE:

11-7-19

ADDRESS:

2709 PRAIRIE WINDS CT

SHEBOYGAN WI 53081

MAIL TO: CLERK'S OFFICE 828 CENTER AVE #100 SHEBOYGAN WI 53081

III

Res. No. _____ - 19 - 20. By Alderpersons Donohue and Bohren.
November 18, 2019.

RESOLUTION AUTHORIZING THE ISSUANCE AND SALE OF UP TO \$2,323,791
SEWERAGE SYSTEM REVENUE BONDS, SERIES 2019D, AND PROVIDING FOR OTHER
DETAILS AND COVENANTS WITH RESPECT THERETO

WHEREAS, the City of Sheboygan, Sheboygan County, Wisconsin (the
"Municipality") owns and operates a sewerage system (the "System") which
is operated for a public purpose as a public utility by the Municipality;
and

WHEREAS, pursuant to a resolution adopted on May 17, 2010 (the "2010
Resolution"), the Municipality has heretofore issued its Sewerage System
Revenue Bonds, Series 2010A, dated May 26, 2010 (the "2010 Bonds"), which
2010 Bonds are payable from the income and revenues of the System; and

WHEREAS, pursuant to a resolution adopted on October 7, 2013 (the
"2013 Resolution"), the Municipality has heretofore issued its Sewerage
System Revenue Bonds, Series 2013A, dated October 23, 2013 (the "2013
Bonds"), which 2013 Bonds are payable from the income and revenues of the
System; and

WHEREAS, the 2010 Bonds and the 2013 Bonds shall collectively be
referred to as the "Prior Bonds"; and

WHEREAS, the 2010 Resolution and the 2013 Resolution shall
collectively be referred to as the "Prior Resolutions"; and

WHEREAS, certain improvements to the System are necessary to meet the
needs of the Municipality and the residents thereof, consisting of the
construction of a project (the "Project") assigned Clean Water Fund
Program Project No. 4019-19 by the Department of Natural Resources, and as
described in the Department of Natural Resources approval letter for the
plans and specifications of the Project, or portions thereof, issued under
Section 281.41, Wisconsin Statutes, assigned No. S-2017-0804 and dated
January 10, 2018 by the DNR; and

WHEREAS, under the provisions of Chapter 66, Wisconsin Statutes any
municipality may, by action of its governing body, provide for purchasing,
acquiring, constructing, extending, adding to, improving, operating and
managing a public utility from the proceeds of bonds, which bonds are to
be payable only from the revenues received from any source by such
utility, including all rentals and fees; and

WHEREAS, the Municipality deems it to be necessary, desirable and in
its best interest to authorize and sell sewerage system revenue bonds of
the Municipality payable solely from the revenues of the System, pursuant

Finances
Personnel

to the provisions of Section 66.0621, Wisconsin Statutes, to pay the cost of the Project; and

WHEREAS, the Prior Resolutions permit the issuance of additional bonds on a parity with the Prior Bonds upon certain conditions, and those conditions have been met; and

WHEREAS, other than the Prior Bonds, no bonds or obligations payable from the revenues of the System are now outstanding.

NOW, THEREFORE, be it resolved by the Governing Body of the Municipality that:

Section 1. Definitions. The following terms shall have the following meanings in this Resolution unless the text expressly or by implication requires otherwise:

(a) "Act" means Section 66.0621, Wisconsin Statutes;

(b) "Bond Registrar" means the Municipal Treasurer which shall act as Paying Agent for the Bonds;

(c) "Bonds" means the \$2,323,791 Sewerage System Revenue Bonds, Series 2019D, of the Municipality dated their date of issuance, authorized to be issued by this Resolution;

(d) "Bond Year" means the twelve-month period ending on each May 1;

(e) "Current Expenses" means the reasonable and necessary costs of operating, maintaining, administering and repairing the System, including salaries, wages, costs of materials and supplies, insurance and audits, but shall exclude depreciation, debt service, tax equivalents and capital expenditures;

(f) "Debt Service Fund" means the Sewerage System Special Redemption Fund of the Municipality, which shall be the "special redemption fund" as such term is defined in the Act;

(g) "Financial Assistance Agreement" means the Financial Assistance Agreement by and between the State of Wisconsin by the Department of Natural Resources and the Department of Administration and the Municipality pursuant to which the Bonds are to be issued and sold to the State, substantially in the form attached hereto and incorporated herein by this reference;

(h) "Fiscal Year" means the twelve-month period ending on each December 31;

(i) "Governing Body" means the Common Council, or such other body as may hereafter be the chief legislative body of the Municipality;

(j) "Gross Earnings" means the gross earnings of the System, including earnings of the System derived from sewerage charges imposed by the Municipality, all payments to the Municipality under any wastewater treatment service agreements between the Municipality and any contract users of the System, and any other monies received from any source including all rentals and fees and any special assessments levied and collected in connection with the Project;

(k) "Municipal Treasurer" means the Treasurer of the Municipality who shall act as Bond Registrar and Paying Agent;

(l) "Municipality" means the City of Sheboygan, Sheboygan County, Wisconsin;

(m) "Net Revenues" means the Gross Earnings of the System after deduction of Current Expenses;

(n) "Parity Bonds" means bonds payable from the revenues of the System other than the Bonds but issued on a parity and equality with the Bonds pursuant to the restrictive provisions of Section 11 of this Resolution;

(o) "Prior Bonds" means the 2010 Bonds and the 2013 Bonds collectively;

(p) "Prior Resolutions" means the 2010 Resolution and the 2013 Resolution collectively;

(q) "Project" means the Project described in the preamble to this Resolution. All elements of the Project are to be owned and operated by the Municipality as part of the System as described in the preamble hereto;

(r) "Record Date" means the close of business on the fifteenth day of the calendar month next preceding any principal or interest payment date;

(s) "System" means the entire sewerage system of the Municipality specifically including that portion of the Project owned by the Municipality and including all property of every nature now or hereafter owned by the Municipality for the collection, transmission, treatment and disposal of domestic and industrial sewerage and waste, including all improvements and extensions thereto made by the Municipality while any of the Bonds and Parity Bonds remain outstanding, including all real and personal property of every nature comprising part of or used or useful in

connection with such sewerage system and including all appurtenances, contracts, leases, franchises, and other intangibles;

(t) "2010 Bonds" means the Municipality's Sewerage System Revenue Bonds, Series 2010A, dated May 26, 2010;

(u) "2010 Resolution" means a resolution adopted by the Common Council on May 17, 2010 authorizing the issuance of the 2010 Bonds;

(v) "2013 Bonds" means the Municipality's Sewerage System Revenue Bonds, Series 2013A, dated October 23, 2013; and

(w) "2013 Resolution" means a resolution adopted by the Common Council on October 7, 2013 authorizing the issuance of the 2013 Bonds.

Section 2. Authorization of the Bonds and the Financial Assistance Agreement. For the purpose of paying the cost of the Project (including legal, fiscal, engineering and other expenses), there shall be borrowed on the credit of the income and revenue of the System up to the sum of \$2,323,791; and fully registered revenue bonds of the Municipality are authorized to be issued in evidence thereof and sold to the State of Wisconsin Clean Water Fund Program in accordance with the terms and conditions of the Financial Assistance Agreement, which is incorporated herein by this reference and the Mayor and City Clerk of the Municipality are hereby authorized, by and on behalf of the Municipality, to execute the Financial Assistance Agreement.

Section 3. Terms of the Bonds. The Bonds shall be designated "Sewerage System Revenue Bonds, Series 2019D" (the "Bonds"); shall be dated their date of issuance; shall be numbered one and upward; shall bear interest at the rate of 1.650% per annum; shall be issued in denominations of \$0.01 or any integral multiple thereof; and shall mature on the dates and in the amounts as set forth in Exhibit B of the Financial Assistance Agreement and in the Bond form attached hereto as Exhibit A as it is from time to time adjusted by the State of Wisconsin based upon the actual draws made by the Municipality. Interest on the Bonds shall be payable commencing on May 1, 2020 and semiannually thereafter on May 1 and November 1 of each year. The Bonds shall not be subject to redemption prior to maturity except as provided in the Financial Assistance Agreement.

The schedule of maturities of the Bonds is found to be such that the amount of annual debt service payments is reasonable in accordance with prudent municipal utility practices.

Section 4. Form, Execution, Registration and Payment of the Bonds. The Bonds shall be issued as registered obligations in substantially the

form attached hereto as Exhibit A and incorporated herein by this reference.

The Bonds shall be executed in the name of the Municipality by the manual signatures of the Mayor and City Clerk, and shall be sealed with its official or corporate seal, if any.

The principal of, premium, if any, and interest on the Bonds shall be paid by the Municipal Treasurer, who is hereby appointed as the Municipality's Bond Registrar.

Both the principal of and interest on the Bonds shall be payable in lawful money of the United States of America by the Bond Registrar. Payment of principal of the final maturity on the Bond will be payable upon presentation and surrender of the Bond to the Bond Registrar. Payment of principal on the Bond (except the final maturity) and each installment of interest shall be made to the registered owner of each Bond who shall appear on the registration books of the Municipality, maintained by the Bond Registrar, on the Record Date and shall be paid by check or draft of the Municipality and mailed to such registered owner at his or its address as it appears on such registration books or at such other address may be furnished in writing by such registered owner to the Bond Registrar.

Section 5. Security for the Bonds. The Bonds, together with interest thereon, shall not constitute an indebtedness of the Municipality nor a charge against its general credit or taxing power. The Bonds, together with interest thereon, shall be payable only out of the Debt Service Fund hereinafter created and established, and shall be a valid claim of the registered owner or owners thereof only against such Debt Service Fund and the revenues of the System pledged to such fund, on a parity with the pledge granted to the holders of the Prior Bonds. Sufficient revenues are hereby pledged to said Debt Service Fund, and shall be used for no other purpose than to pay the principal of, premium, if any, and interest on the Prior Bonds, the Bonds and any Parity Bonds as the same becomes due.

Section 6. Funds and Accounts. In accordance with the Act, for the purpose of the application and proper allocation of the revenues of the System, and to secure the payment of the principal of and interest on the Prior Bonds, the Bonds and Parity Bonds, certain funds of the System which were created and established by a resolution adopted on October 18, 1993, as amended, are hereby continued and shall be used solely for the following respective purposes:

- (a) Revenue Fund, into which shall be deposited as received the Gross Earnings of the System, which money shall then be divided among the Operation and Maintenance Fund, the Debt Service Fund,

the Depreciation Fund and the Surplus Fund in the amounts and in the manner set forth in Section 7 hereof and used for the purposes described below.

- (b) Operation and Maintenance Fund, which shall be used for the payment of Current Expenses.
- (c) Sewerage System Special Redemption Fund (the "Debt Service Fund"), which shall be used for the payment of the principal of, premium, if any, and interest on the Prior Bonds, the Bonds and Parity Bonds as the same becomes due, and which may contain a Reserve Account established by a future resolution authorizing the issuance of Parity Bonds to secure such Parity Bonds.
- (d) Depreciation Fund, which shall be used to provide a proper and adequate depreciation account for the System.
- (e) Surplus Fund, which shall first be used whenever necessary to pay principal of, premium, if any, or interest on the Prior Bonds, the Bonds and Parity Bonds when the Debt Service Fund shall be insufficient for such purpose, and thereafter shall be disbursed as follows: (i) at any time, to remedy any deficiency in any of the Funds provided in this Section 6 hereof; and (ii) money thereafter remaining in the Surplus Fund at the end of any Fiscal Year may be transferred to any of the funds or accounts created herein or to reimburse the general fund of the Municipality for advances made by the Municipality to the System.

Section 7. Application of Revenues. After the delivery of the Bonds, the Gross Earnings of the System shall be deposited as collected in the Revenue Fund and shall be transferred monthly to the funds listed below in the following order of priority and in the manner set forth below:

- (a) to the Operation and Maintenance Fund, in an amount equal to the estimated Current Expenses for such month and for the following month (after giving effect to available amounts in said Fund from prior deposits);
- (b) to the Debt Service Fund, an amount equal to one-sixth (1/6) of the next installment of interest coming due on the Prior Bonds, the Bonds and any Parity Bonds then outstanding and an amount equal to one-twelfth (1/12) of the installment of principal of the Prior Bonds, the Bonds and any Parity Bonds coming due during such Bond Year (after giving effect to available amounts in said Fund from accrued interest, any premium or any other source), and any amount required by a future resolution

authorizing the issuance of Parity Bonds to fund a Reserve Account established therein;

- (c) to the Depreciation Fund, an amount determined by the Governing Body to be sufficient to provide a proper and adequate depreciation account for the System; and
- (d) to the Surplus Fund, any amount remaining in the Revenue Fund after the monthly transfers required above have been completed.

Transfers from the Revenue Fund to the Operation and Maintenance Fund, the Debt Service Fund, the Depreciation Fund and the Surplus Fund shall be made monthly not later than the tenth day of each month, and such transfer shall be applicable to monies on deposit in the Revenue Fund as of the last day of the month preceding. Any other transfers and deposits to any fund required or permitted by subsection (a) through (d) of this Section, except transfers or deposits which are required to be made immediately or annually, shall be made on or before the tenth day of the month. Any transfer or deposit required to be made at the end of any Fiscal Year shall be made within sixty (60) days after the close of such Fiscal Year. If the tenth day of any month shall fall on a day other than a business day, such transfer or deposit shall be made on the next succeeding business day.

It is the express intent and determination of the Governing Body that the amounts transferred from the Revenue Fund and deposited in the Debt Service Fund shall be sufficient in any event to pay the interest on the Prior Bonds, the Bonds and any Parity Bonds as the same accrues and the principal thereof as the same matures, and to fund the Reserve Account as required in connection with future Parity Bonds.

Section 8. Deposits and Investments. The Debt Service Fund shall be kept apart from monies in the other funds and accounts of the Municipality and the same shall be used for no purpose other than the prompt payment of principal of and interest on the Prior Bonds, the Bonds and any Parity Bonds as the same becomes due and payable. All monies therein shall be deposited in special and segregated accounts in a public depository selected under Chapter 34, Wisconsin Statutes and may be temporarily invested until needed in legal investments subject to the provisions of Section 66.0603(1m), Wisconsin Statutes. The other funds herein created (except the Sewerage System CFWP Project Fund) may be combined in a single account in a public depository selected in the manner set forth above and may be temporarily invested until needed in legal investments subject to the provisions of Section 66.0603(1m), Wisconsin Statutes.

Section 9. Service to the Municipality. The reasonable cost and value of services rendered to the Municipality by the System by furnishing sewerage services for public purposes shall be charged against the

Municipality and shall be paid in monthly installments as the service accrues, out of the current revenues of the Municipality collected or in the process of collection, exclusive of the revenues derived from the System; that is to say, out of the tax levy of the Municipality made by it to raise money to meet its necessary current expenses. The reasonable cost and value of such service to the Municipality in each year shall be equal to an amount which, together with other revenues of the System, will produce in each Fiscal Year Net Revenues equivalent to not less than the annual principal and interest requirements on the Prior Bonds, the Bonds, any Parity Bonds and any other obligations payable from the revenues of the System then outstanding, times the greater of (i) 110% or (ii) the highest debt service coverage ratio required with respect to any obligations payable from revenues of the System then outstanding. However, such payment out of the tax levy shall be subject to (a) approval of the Public Service Commission, or successors to its function, if applicable, (b) yearly appropriations therefor, and (c) applicable levy limitations, if any; and neither this Resolution nor such payment shall be construed as constituting an obligation of the Municipality to make any such appropriation over and above the reasonable cost and value of the services rendered to the Municipality and its inhabitants or to make any subsequent payment over and above such reasonable cost and value.

Section 10. Operation of System; Municipality Covenants. It is covenanted and agreed by the Municipality with the owner or owners of the Bonds, and each of them, that the Municipality will perform all of the obligations of the Municipality as set forth in the Financial Assistance Agreement.

Section 11. Additional Bonds. The Bonds are issued on a parity with the Prior Bonds as to the pledge of revenues of the System. No bonds or obligations payable out of the revenues of the System may be issued in such manner as to enjoy priority over the Bonds. Additional obligations may be issued if the lien and pledge is junior and subordinate to that of the Bonds. Parity Bonds may be issued only under the following circumstances:

(a) Additional Parity Bonds may be issued for the purpose of completing the Project and for the purpose of financing costs of the Project which are ineligible for payment under the State of Wisconsin Clean Water Fund Program. However, such additional Parity Bonds shall be in an aggregate amount not to exceed 20% of the face amount of the Bonds; or

(b) Additional Parity Bonds may also be issued if all of the following conditions are met:

(1) The Net Revenues of the System for the Fiscal Year immediately preceding the issuance of such additional bonds must

have been in an amount at least equal to the maximum annual interest and principal requirements on all bonds outstanding payable from the revenues of the System, and on the bonds then to be issued, times the greater of (i) 1.10 or (ii) the highest debt service coverage ratio to be required with respect to the Additional Parity Bonds to be issued or any other obligations payable from the revenues of the System then outstanding. Should an increase in permanent rates and charges, including those made to the Municipality, be properly ordered and made effective during the Fiscal Year immediately prior to the issuance of such additional bonds or during that part of the Fiscal Year of issuance prior to such issuance, then Net Revenues for purposes of such computation shall include such additional revenues as an independent certified public accountant, consulting professional engineer or the Wisconsin Public Service Commission may certify would have accrued during the prior Fiscal Year had the new rates been in effect during that entire immediately prior Fiscal Year.

(2) The payments required to be made into the funds enumerated in Section 6 of this Resolution must have been made in full.

(3) The additional bonds must have principal maturing on May 1 of each year and interest falling due on May 1 and November 1 of each year.

(4) The proceeds of the additional bonds must be used only for the purpose of providing extensions or improvements to the System, or to refund obligations issued for such purpose.

Section 12. Sale of Bonds. The sale of the Bonds to the State of Wisconsin Clean Water Fund Program for the purchase price of up to \$2,323,791 and at par, is ratified and confirmed; and the officers of the Municipality are authorized and directed to do any and all acts, including executing the Financial Assistance Agreement and the Bonds as hereinabove provided, necessary to conclude delivery of the Bonds to said purchaser, as soon after adoption of this Resolution as is convenient. The purchase price for the Bonds shall be paid upon requisition therefor as provided in the Financial Assistance Agreement, and the officers of the Municipality are authorized to prepare and submit to the State requisitions and disbursement requests in anticipation of the execution of the Financial Assistance Agreement and the issuance of the Bonds.

Section 13. Application of Bond Proceeds. The proceeds of the sale of the Bonds shall be deposited by the Municipality into a special fund designated as "Sewerage System CWFP Project Fund." The Sewerage System CWFP Project Fund shall be used solely for the purpose of paying the costs

of the Project as more fully described in the preamble hereof and in the Financial Assistance Agreement. Moneys in the Sewerage System CWFPP Project Fund shall be disbursed within three (3) business days of their receipt from the State of Wisconsin and shall not be invested in any interest-bearing account.

Section 14. Amendment to Resolution. After the issuance of any of the Bonds, no change or alteration of any kind in the provisions of this Resolution may be made until all of the Bonds have been paid in full as to both principal and interest, or discharged as herein provided, except: (a) the Municipality may, from to time, amend this Resolution without the consent of any of the owners of the Bonds, but only to cure any ambiguity, administrative conflict, formal defect, or omission or procedural inconsistency of this Resolution; and (b) this Resolution may be amended, in any respect, with a written consent of the owners of not less than two-thirds (2/3) of the principal amount of the Bonds then outstanding, exclusive of Bonds held by the Municipality; provided, however, that no amendment shall permit any change in the pledge of revenues derived from the System or the maturity of any Bond issued hereunder, or a reduction in the rate of interest on any Bond, or in the amount of the principal obligation thereof, or in the amount of the redemption premium payable in the case of redemption thereof, or change the terms upon which the Bonds may be redeemed or make any other modification in the terms of the payment of such principal or interest without the written consent of the owner of each such Bond to which the change is applicable.

Section 15. Defeasance. When all Bonds have been discharged, all pledges, covenants and other rights granted to the owners thereof by this Resolution shall cease. The Municipality may discharge all Bonds due on any date by irrevocably depositing in escrow with a suitable bank or trust company a sum of cash and/or bonds or securities issued or guaranteed as to principal and interest of the U.S. Government, or of a commission, board or other instrumentality of the U.S. Government, maturing on the dates and bearing interest at the rates required to provide funds sufficient to pay when due the interest to accrue on each of said Bonds to its maturity or, at the Municipality's option, if said Bond is prepayable to any prior date upon which it may be called for redemption, and to pay and redeem the principal amount of each such Bond at maturity, or at the Municipality's option, if said Bond is prepayable, at its earliest redemption date, with the premium required for such redemption, if any, provided that notice of the redemption of all prepayable Bonds on such date has been duly given or provided for.

Section 16. Rebate Fund. Unless the Bonds are exempt from the rebate requirements of the Internal Revenue Code of 1986, as amended (the "Code"), the Municipality shall establish and maintain, so long as the Bonds and any Parity Bonds are outstanding, a separate account to be known as the "Rebate Fund." The sole purpose of the Rebate Fund is to provide

for the payment of any rebate liability with respect to the Bonds under the relevant provisions of the Code and the Treasury Regulations promulgated thereunder (the "Regulations"). The Rebate Fund shall be maintained by the Municipality until all required rebate payments with respect to the Bonds have been made in accordance with the relevant provisions of the Code and the Regulations.

The Municipality hereby covenants and agrees that it shall pay to the United States from the Rebate Fund, at the times and in the amounts and manner required by the Code and the Regulations, the portion of the "rebate amount" (as defined in Section 1.148-3(b) of the Regulations) that is due as of each "computation date" (within the meaning of Section 1.148-3(e) of the Regulations). As of the date of this Resolution, the provisions of the Regulations specifying the required amounts of rebate installment payments and the time and manner of such payments are contained in Sections 1.148-3(f) and (g) of the Regulations, respectively. Amounts held in the Rebate Fund and the investment income therefrom are not pledged as security for the Bonds or any Parity Bonds and may only be used for the payment of any rebate liability with respect to the Bonds.

The Municipality may engage the services of accountants, attorneys or other consultants necessary to assist it in determining the rebate payments, if any, owed to the United States with respect to the Bonds. The Municipality shall maintain or cause to be maintained records of determinations of rebate liability with respect to the Bonds for each computation date until six (6) years after the retirement of the last of the Bonds. The Municipality shall make such records available to the State of Wisconsin upon reasonable request therefor.

Section 17. Resolution a Contract. The provisions of this Resolution shall constitute a contract between the Municipality and the owner or owners of the Bonds, and after issuance of any of the Bonds no change or alteration of any kind in the provisions of this Resolution may be made, except as provided in Section 14, until all of the Bonds have been paid in full as to both principal and interest. The owner or owners of any of the Bonds shall have the right in addition to all other rights, by mandamus or other suit or action in any court of competent jurisdiction, to enforce such owner's or owners' rights against the Municipality, the Governing Body thereof, and any and all officers and agents thereof including, but without limitation, the right to require the Municipality, its Governing Body and any other authorized body, to fix and collect rates and charges fully adequate to carry out all of the provisions and agreements contained in this Resolution.

Section 18. Continuing Disclosure. The officers of the Municipality are hereby authorized and directed, if requested by the State of Wisconsin, to provide to the State of Wisconsin Clean Water Fund Program and to such other persons or entities as directed by the State of

Wisconsin such ongoing disclosure regarding the Municipality's financial condition and other matters, at such times and in such manner as the Clean Water Fund Program may require, in order that securities issued by the Municipality and the State of Wisconsin satisfy rules and regulations promulgated by the Securities and Exchange Commission under the Securities Exchange Act of 1934, as amended and as it may be amended from time to time, imposed on brokers and dealers of municipal securities before the brokers and dealers may buy, sell, or recommend the purchase of such securities.

Section 19. Conflicting Resolutions. All ordinances, resolutions (other than the Prior Resolutions), or orders, or parts thereof heretofore enacted, adopted or entered, in conflict with the provisions of this Resolution, are hereby repealed and this Resolution shall be in effect from and after its passage. In case of any conflict between this Resolution and the Prior Resolutions, the Prior Resolutions shall control as long as any of the respective Prior Bonds are outstanding.

I HEREBY CERTIFY that the foregoing Resolution was duly passed by the Common Council of the City of Sheboygan, Wisconsin, on the _____ day of _____, 20____.

Dated _____ 20____. _____, City Clerk

Approved _____ 20____. _____, Mayor

EXHIBIT A

(Form of Municipal Obligation)

REGISTERED NO. _____ SHEBOYGAN CITY OF SHEBOYGAN	UNITED STATES OF AMERICA STATE OF WISCONSIN	REGISTERED \$ _____ COUNTY
---	--	----------------------------------

SEWERAGE SYSTEM REVENUE BOND, SERIES 2019D

<u>Final Maturity Date</u>	<u>Date of Original Issue</u>
May 1, 2039	_____, 20__

REGISTERED OWNER: STATE OF WISCONSIN CLEAN WATER FUND PROGRAM

FOR VALUE RECEIVED the City of Sheboygan, Sheboygan County, Wisconsin (the "Municipality") hereby acknowledges itself to owe and promises to pay to the registered owner shown above, or registered assigns, solely from the fund hereinafter specified, the principal sum of an amount not to exceed _____ DOLLARS (\$_____) (but only so much as shall have been drawn hereunder, as provided below) on May 1 of each year commencing May 1, 2020 until the final maturity date written above, together with interest thereon (but only on amounts as shall have been drawn hereunder, as provided below) from the dates the amounts are drawn hereunder or the most recent payment date to which interest has been paid, at the rate of 1.650% per annum, calculated on the basis of a 360-day year made up of twelve 30-day months, such interest being payable on the first days of May and November of each year, with the first interest being payable on May 1, 2020.

The principal amount evidenced by this Bond may be drawn upon by the Municipality in accordance with the Financial Assistance Agreement entered by and between the Municipality and the State of Wisconsin by the Department of Natural Resources and the Department of Administration including capitalized interest transferred (if any). The principal amounts so drawn shall be repaid in installments on May 1 of each year commencing on May 1, 2020 in an amount equal to an amount which when amortized over the remaining term of this Bond plus current payments of interest (but only on amounts drawn hereunder) at One and 650/1000ths percent (1.650%) per annum shall result in equal annual payments of the total of principal and the semiannual payments of interest. The State of Wisconsin Department of Administration shall record such draws and corresponding principal repayment schedule on a cumulative basis in the format shown on the attached Schedule A.

Both principal and interest hereon are hereby made payable to the registered owner in lawful money of the United States of America. On the final maturity date, principal of this Bond shall be payable only upon presentation and surrender of this Bond at the office of the Municipal Treasurer. Principal hereof (except the final maturity) and interest hereon shall be payable by electronic transfer or by check or draft dated on or before the applicable payment date and mailed from the office of the Municipal Treasurer to the person in whose name this Bond is registered at the close of business on the fifteenth day of the calendar month next preceding such interest payment date.

The Bonds shall not be redeemable prior to their maturity, except with the consent of the registered owner.

This Bond is transferable only upon the books of the Municipality kept for that purpose at the office of the Municipal Treasurer, by the registered owner in person or its duly authorized attorney, upon surrender of this Bond, together with a written instrument of transfer (which may be endorsed hereon) satisfactory to the Municipal Treasurer, duly executed by the registered owner or its duly authorized attorney. Thereupon a replacement Bond shall be issued to the transferee in exchange therefor. The Municipality may deem and treat the person in whose name this Bond is registered as the absolute owner hereof for the purpose of receiving payment of or on account of the principal or interest hereof and for all other purposes. This Bond is issuable solely as a negotiable, fully-registered bond, without coupons, and in denominations of \$0.01 or any integral multiple thereof.

This Bond is issued for the purpose of providing for the payment of the cost of constructing improvements to the Sewerage System of the Municipality, pursuant to Article XI, Section 3, of the Wisconsin Constitution, Section 66.0621, Wisconsin Statutes, and a resolution adopted December 2, 2019, and entitled: "Resolution Authorizing the Issuance and Sale of Up to \$2,323,791 Sewerage System Revenue Bonds, Series 2019D, and Providing for Other Details and Covenants With Respect Thereto" and is payable only from the income and revenues of the Sewerage System of the Municipality (the "Utility"). The Bonds are issued on a parity with the Municipality's Sewerage System Revenue Bonds, Series 2010A, dated May 26, 2010 and Sewerage System Revenue Bonds, Series 2013A, dated October 23, 2013, as to the pledge of income and revenues of the Utility. This Bond does not constitute an indebtedness of said Municipality within the meaning of any constitutional or statutory debt limitation or provision.

It is hereby certified, recited and declared that all acts, conditions and things required to exist, happen, and be performed precedent to and in the issuance of this Bond have existed, have happened and have been performed in due time, form and manner as required by law; and that sufficient of the income and revenue to be received by said Municipality from the operation of its Utility has been pledged to and will be set aside into a special fund for the payment of the principal of and interest on this Bond.

IN WITNESS WHEREOF, the Municipality has caused this Bond to be signed by the signatures of its Mayor and City Clerk, and its corporate seal to be impressed hereon, all as of the date of original issue specified above.

CITY OF SHEBOYGAN,
WISCONSIN

(SEAL)

By: _____
Michael J. Vandersteen
Mayor

By: _____
Meredith DeBruin
City Clerk

(Form of Assignment)

FOR VALUE RECEIVED the undersigned hereby sells, assigns and transfers unto

(Please print or typewrite name and address, including zip code, of Assignee)

Please insert Social Security or other identifying number of Assignee

the within Bond and all rights thereunder, hereby irrevocably constituting and appointing

Attorney to transfer said Bond on the books kept for the registration thereof with full power of substitution in the premises.

Dated: _____

NOTICE: The signature of this assignment must correspond with the name as it appears upon the face of the within Bond in every particular, without alteration or enlargement or any change whatever.

Signature(s) guaranteed by

SCHEDULE A

\$2,323,791

CITY OF SHEBOYGAN, WISCONSIN
SEWERAGE SYSTEM REVENUE BONDS, SERIES 2019D

<u>Amount of Disbursement</u>	<u>Date of Disbursement</u>	<u>Series of Bonds</u>	<u>Principal Repaid</u>	<u>Principal Balance</u>
_____	_____	_____	_____	_____
_____	_____	_____	_____	_____
_____	_____	_____	_____	_____
_____	_____	_____	_____	_____
_____	_____	_____	_____	_____
_____	_____	_____	_____	_____
_____	_____	_____	_____	_____
_____	_____	_____	_____	_____
_____	_____	_____	_____	_____
_____	_____	_____	_____	_____
_____	_____	_____	_____	_____

SCHEDULE A (continued)

PRINCIPAL REPAYMENT SCHEDULE

<u>Date</u>	<u>Principal Amount</u>
May 1, 2020	\$99,018.18
May 1, 2021	100,651.98
May 1, 2022	102,312.73
May 1, 2023	104,000.89
May 1, 2024	105,716.91
May 1, 2025	107,461.24
May 1, 2026	109,234.35
May 1, 2027	111,036.72
May 1, 2028	112,868.82
May 1, 2029	114,731.16
May 1, 2030	116,624.22
May 1, 2031	118,548.52
May 1, 2032	120,504.57
May 1, 2033	122,492.90
May 1, 2034	124,514.03
May 1, 2035	126,568.51
May 1, 2036	128,656.89
May 1, 2037	130,779.73
May 1, 2038	132,937.59
May 1, 2039	135,131.06

State of Wisconsin
Department of Natural Resources
Bureau of Community Financial Assistance
101 South Webster Street, 2nd Floor
PO Box 7921
Madison, Wisconsin 53707-7921

Financial Assistance Agreement
Clean Water Fund Program
Form 8700-214A rev 01/19

STATE OF WISCONSIN CLEAN WATER FUND PROGRAM
FINANCIAL ASSISTANCE AGREEMENT WITH PRINCIPAL FORGIVENESS

STATE OF WISCONSIN
DEPARTMENT OF NATURAL RESOURCES
DEPARTMENT OF ADMINISTRATION

and

CITY OF SHEBOYGAN

\$3,073,791 With up to \$750,000 PRINCIPAL FORGIVENESS

FINANCIAL ASSISTANCE AGREEMENT

Dated as of December 11, 2019

This constitutes a **Financial Assistance Agreement** under the State of Wisconsin's Clean Water Fund Program. This agreement is awarded pursuant to ss. 281.58 and 281.59, Wis. Stats. The purpose of this agreement is to award financial assistance from the Clean Water Fund Program. This agreement also discloses the terms and conditions of this award.

This agreement is only effective when signed by authorized officers of the municipality and an authorized officer of the State of Wisconsin Department of Natural Resources and of the State of Wisconsin Department of Administration.

The Department of Natural Resources and the Department of Administration may rescind or terminate this agreement if the municipality fails to comply with the terms and conditions contained within. Any determination or certification made in this agreement by the Department of Natural Resources or the Department of Administration is made solely for the purpose of providing financial assistance under the Clean Water Fund Program.

Municipal Identification No. 59281
Clean Water Fund Program Project No. 4019-19

TABLE OF CONTENTS

ARTICLE I DEFINITIONS; RULES OF INTERPRETATION

Section 1.01.	Definitions	2
Section 1.02.	Rules of Interpretation	5

ARTICLE II REPRESENTATIONS

Section 2.01.	Representations of the CWFP	6
Section 2.02.	Representations of the Municipality	6

ARTICLE III LOAN PROVISIONS

Section 3.01.	Loan Clauses	10
Section 3.02.	Municipal Obligations Amortization	10
Section 3.03.	Type of Municipal Obligation and Security	11
Section 3.04.	Other Amounts Payable	11
Section 3.05.	Sale and Redemption of Municipal Obligations	11
Section 3.06.	Disbursement of Financial Assistance	12
Section 3.07.	Remedies	13
Section 3.08.	Security for the Municipal Obligations	14
Section 3.09.	Effective Date and Term	14

ARTICLE IV CONSTRUCTION OF THE PROJECT

Section 4.01.	Insurance	15
Section 4.02.	Construction of the Project	15
Section 4.03.	Performance Bonds	15
Section 4.04.	Completion of the Project	15
Section 4.05.	Payment of Additional Project Costs	16
Section 4.06.	No Warranty Regarding Condition, Suitability, or Cost of Project	16

ARTICLE V COVENANTS

Section 5.01.	Application of Financial Assistance	17
Section 5.02.	Operation and Maintenance; Equipment Replacement Fund	17
Section 5.03.	Compliance with Law	17
Section 5.04.	Public Ownership	17
Section 5.05.	Establishment of Project Accounts; Audits	17
Section 5.06.	Records	18
Section 5.07.	Project Areas	18
Section 5.08.	Engineering Inspection	18
Section 5.09.	Tax Covenants	18
Section 5.10.	User Fee Covenant	19
Section 5.11.	Notice of Impaired System	19
Section 5.12.	Hold Harmless	19
Section 5.13.	Nondiscrimination Covenant	19
Section 5.14.	Employees	20
Section 5.15.	Adequate Funds	20

Section 5.16.	Management	20
Section 5.17.	Reimbursement	20
Section 5.18.	Unpaid User Fees	20
Section 5.19.	Sewer Use Ordinance	20
Section 5.20.	Rebates	20
Section 5.21.	Maintenance of Legal Existence	20
Section 5.22.	Wage Rate Requirements	21
Section 5.23.	Fiscal Sustainability Plan	21
Section 5.24.	Use of American Iron and Steel	21

**ARTICLE VI
MISCELLANEOUS**

Section 6.01.	Notices	22
Section 6.02.	Binding Effect	22
Section 6.03.	Severability	22
Section 6.04.	Amendments, Supplements, and Modifications	22
Section 6.05.	Execution in Counterparts	22
Section 6.06.	Applicable Law	22
Section 6.07.	Benefit of Financial Assistance Agreement	23
Section 6.08.	Further Assurances	23
Section 6.09.	Assignment of Municipal Obligations	23
Section 6.10.	Covenant by Municipality as to Compliance with General Resolution	23
Section 6.11.	Termination	23
Section 6.12.	Rescission	23

EXHIBIT A	PROJECT BUDGET SHEET	
EXHIBIT B	LOAN AMORTIZATION SCHEDULE	
EXHIBIT C	LOAN DISBURSEMENT TABLE	
EXHIBIT D	OPERATING CONTRACTS	
EXHIBIT E	DISADVANTAGED BUSINESS ENTERPRISES CONTRACT UTILIZATION	
EXHIBIT F	PROJECT MANAGER SUMMARY PAGE	
EXHIBIT G	FEDERAL REQUIREMENTS COMPLIANCE CERTIFICATION	

WITNESSETH:

WHEREAS, this is a FINANCIAL ASSISTANCE AGREEMENT (the "FAA"), dated December 11, 2019, between the STATE OF WISCONSIN Clean Water Fund Program (the "CWFP"), by the Department of Natural Resources (the "DNR") and the Department of Administration (the "DOA"), acting under authority of ss. 281.58 and 281.59, Wis. Stats., as amended (the "Statute"), and the City of Sheboygan, a municipality within the meaning of the Statute, duly organized and existing under the laws of the State of Wisconsin (the "Municipality"); and

WHEREAS, the United States, pursuant to the Federal Water Quality Act of 1987 (the "Water Quality Act"), requires each state to establish a water pollution control revolving fund to be administered by an instrumentality of the state before the state may receive capitalization grants for eligible projects from the United States Environmental Protection Agency (the "EPA"), or any successor which may succeed to the administration of the program established by Title VI of the Water Quality Act; and

WHEREAS, the State of Wisconsin, pursuant to ss. 281.58 and 281.59, Wis. Stats., established the CWFP to be used in part for purposes of the Water Quality Act; and

WHEREAS, the State of Wisconsin, pursuant to s. 25.43, Wis. Stats., established a State of Wisconsin Environmental Improvement Fund which includes the CWFP; and

WHEREAS, DNR and DOA have the joint responsibility to provide CWFP financial assistance to municipalities for the construction of eligible wastewater pollution abatement projects, all as set forth in the Statute; and

WHEREAS, the Municipality submitted to DNR an application for financial assistance (the "Application") for a project (the "Project"), DNR has approved the Application and determined the Application meets the criteria for Project eligibility based on water quality and public health requirements established in applicable state statutes and regulations; and

WHEREAS, DNR determined that the Municipality and the Project are eligible for financial assistance pursuant to s. 281.58(7)(b), Wis. Stats.; and

WHEREAS, DOA determined the CWFP will provide financial assistance to the Municipality by making a loan (the "Loan") under s. 281.59(9), Wis. Stats., for the purposes of that subsection, and providing principal forgiveness; and

WHEREAS, the Municipality pledged the security, if any, required by DOA, and the Municipality demonstrated to the satisfaction of DOA the financial capacity to ensure sufficient revenues to operate and maintain the Project for its useful life and to pay debt service on the obligations it issues for the Project; and

WHEREAS, the Municipality certifies to the CWFP that it has created a dedicated source of revenue, which may constitute taxes levied by the Municipality for repayment of the Municipal Obligations; and

WHEREAS, the Municipality obtained DNR approval of facility plans or engineering reports and plans and specifications for the Project, subject to the provisions of applicable State environmental standards set forth in law, rules, and regulations;

NOW, THEREFORE, in consideration of the promises and of the mutual representations, covenants, and agreements herein set forth, the CWFP and the Municipality, each binding itself, its successors, and its assigns, do mutually promise, covenant, and agree as follows:

ARTICLE I
DEFINITIONS; RULES OF INTERPRETATION

Section 1.01. Definitions The following capitalized terms as used in this FAA shall have the following meanings:

"Act" means the Federal Water Pollution Control Act, 33 U.S. Code §§1250 et seq., as amended.

"Application" means the written application of the Municipality dated September 18, 2018, for financial assistance under the Statute.

"Bonds" means bonds or notes issued by the State pursuant to the General Resolution, all or a portion of the proceeds of which shall be applied to make the Loan.

"Business Day" means any day on which State offices are open to conduct business.

"CWFP" means the State of Wisconsin Clean Water Fund Program, established pursuant to ss. 281.58 and 281.59, Wis. Stats., and managed and administered by DNR and DOA.

"Code" means the Internal Revenue Code of 1986, as amended, and any successor provisions.

"DNR" means the State of Wisconsin Department of Natural Resources and any successor entity.

"DOA" means the State of Wisconsin Department of Administration and any successor entity.

"EPA" means the United States Environmental Protection Agency or any successor entity that may succeed to the administration of the program established by Title VI of the Water Quality Act.

"FAA" means this Financial Assistance Agreement.

"Fees and Charges" means the costs and expenses of DNR and DOA in administering the CWFP.

"Final Completion" means the Project construction is complete, DNR or agents thereof have certified that the Project was constructed according to DNR approved Plans and Specifications and that the facilities are operating according to design, and DNR has completed all necessary Project closeout procedures.

"Financial Assistance" means any proceeds provided under this Financial Assistance Agreement in the form of a Loan of which part of the Loan principal will be forgiven.

"Financial Assistance Agreement" means this Financial Assistance Agreement between the CWFP by DNR, DOA, and the Municipality, as the same may be amended from time to time in accordance with Section 6.04 hereof.

"Fiscal Sustainability Plan" means a plan meeting the minimum requirements of section 603(d)(1)(E) of the Act.

"General Resolution" means the Clean Water Revenue Bond General Resolution adopted by the State of Wisconsin Building Commission, as such may from time to time be amended or supplemented by Series Resolutions or Supplemental Resolutions in accordance with the terms and provisions of the General Resolution.

"Loan" means the loan or loans made by the CWFP to the Municipality of which a portion of the principal will be forgiven pursuant to this FAA.

"Loan Disbursement Table" means the table, the form of which is included as Exhibit C hereto, with columns for inserting the following information for the portion of the Loan which is to be repaid with interest:

- (a) amount of each disbursement,
- (b) date of each disbursement,
- (c) the series of Bonds from which each disbursement is made,
- (d) principal amounts repaid, and
- (e) outstanding principal balance.

"Municipal Obligation Counsel Opinion" means the opinion of counsel satisfactory to DOA, issued in conjunction with the Municipal Obligations, stating that:

- (a) the FAA and the performance by the Municipality of its obligations thereunder have been duly authorized by all necessary actions by the governing body of the Municipality, and the FAA has been duly executed and delivered by the Municipality;
- (b) the Municipal Obligations have been duly authorized, executed, and delivered by the Municipality and sold to the CWFP;
- (c) each of the FAA and the Municipal Obligations constitutes a legal, valid, and binding obligation of the Municipality, enforceable against the Municipality in accordance with its respective terms (provided that enforceability thereof may be subject to bankruptcy, insolvency, reorganization, moratorium, and other similar laws affecting creditors' rights heretofore or hereafter enacted to the extent constitutionally applicable and that its enforcement may also be subject to the exercise of judicial discretion in appropriate cases);
- (d) the Municipal Obligations constitute special obligations of the Municipality secured as to payment of principal, interest, and redemption price by the pledged revenues as set forth therein;
- (e) interest on the Municipal Obligations is not included in gross income of the owners thereof for federal income taxation purposes under existing laws, regulations, rulings, and judicial decisions;
- (f) the Municipal Obligations are not "arbitrage bonds" within the meaning of Section 148 of the Code and the arbitrage regulations; and
- (g) the Municipal Obligations are not "private activity bonds" as defined in Section 141(a) of the Code.

"Municipal Obligation Resolution" means that action taken by the governing body of the Municipality authorizing the issuance of the Municipal Obligations.

"Municipal Obligations" means the bonds or notes issued and delivered by the Municipality to the CWFP, a specimen copy of which is included in the Municipal Obligations transcript in exchange for the portion of the Loan which is not subject to Principal Forgiveness.

"Municipality" means City of Sheboygan, a "municipality" within the meaning of the Statute, duly organized and existing under the laws of the State, and any successor entity.

"Parallel Cost Percentage" means the proportion of Project Costs eligible for below-market-rate financing relative to the total Project Costs eligible for CWFP financing.

"Parity Obligations" means the Municipality's \$2,947,632 Sewerage System Revenue Bonds, Series 2010A, dated May 26, 2010; its \$8,974,081 Sewerage System Revenue Bonds, Series 2013A, dated October 23, 2013; and any other obligations issued on a parity with the Municipal Obligations pursuant to the restrictive provisions of Section 11 of the Municipal Obligation Resolution.

"Plans and Specifications" means the Project design plans and specifications assigned No. S-2017-0804, approved by DNR on January 10, 2018, as the same may be amended or modified from time to time in accordance with this FAA.

"Principal Forgiveness" means Financial Assistance received in the form of forgiveness of Loan principal pursuant to the Act, Regulations, and this FAA of which no repayment thereof shall be required except as may be required per the Act, Statutes, Regulations, or this FAA. The amount of principal forgiveness available for this Project as of the date of this FAA is \$750,000. The applicable percentage of principal forgiveness for this Project, as shown on the Final Funding List, is 25%.

"Progress payments" means payments for work in place and materials or equipment that have been delivered or are stockpiled in the vicinity of the construction site. This includes payments for undelivered, specifically manufactured equipment if: (1) designated in the specifications, (2) could not be readily utilized or diverted to another job, and (3) a fabrication period of more than 6 months is anticipated.

"Project" means the project assigned CWFP Project No. 4019-19 by DNR, described in the Project Manager Summary Page (Exhibit F), and further described in the DNR approval letter for the Plans and Specifications, or portions thereof, issued under s. 281.41, Wis. Stats.

"Project Costs" means the costs of the Project that are eligible for financial assistance from the CWFP under the Statute, which are allowable costs under the Regulations, which have been incurred by the Municipality, an estimate of which is set forth in Exhibit A hereto and made a part hereof.

"Regulations" means the Act, and chs. NR 108, NR 110, NR 150, NR 151, NR 162, and NR 216, Wis. Adm. Code, the regulations of DNR, and ch. Adm. 35, Wis. Adm. Code, the regulations of DOA, adopted pursuant to and in furtherance of the Act, as such may be adopted or amended from time to time.

"Series Resolution" or "Supplemental Resolution" shall have the meaning set forth in the General Resolution.

"Servicing Fee" means any servicing fee that may be imposed by DNR and DOA pursuant to s. 281.58(9)(d), Wis. Stats., which shall cover the estimated costs of reviewing and acting upon the Application and servicing this FAA, and which the Municipality is obligated to pay as set forth in Section 3.04 hereof.

"Sewer Use Ordinance" means the ordinance (or other legislative enactments) meeting the requirements of the Regulations and enacted and enforced in each jurisdiction served by the Project.

"Sewerage System" means the entire sewerage system of the Municipality, specifically including that portion of the Project owned by the Municipality and including all property of every nature now or hereafter owned by the Municipality for the collection, transmission, treatment, and disposal of domestic and industrial sewerage and waste.

"State" means the State of Wisconsin.

"Statute" means ss. 281.58 and 281.59, Wis. Stats., as amended.

"Substantial Completion" means the date on which construction of the Project is sufficiently complete in accordance with the contract documents so that the owner can occupy and utilize the Project for its intended use.

"Trustee" means the trustee appointed by the State pursuant to the General Resolution and any successor trustee.

"Use of American Iron and Steel" means the requirements contained in section 608 of the Act.

"User Charge System" means a system of charges meeting the requirements of s. NR 162.08, Wis. Adm. Code.

"User Fees" means fees charged or to be charged to users of the Project or the Sewerage System of which the Project is a part pursuant to a User Charge System or otherwise.

"Water Quality Act" means the federal Water Quality Act of 1987, as amended.

"WPDES Permit" means a Wisconsin Pollutant Discharge Elimination System permit issued under ch. 283, Wis. Stats.

Section 1.02. Rules of Interpretation Unless the context clearly indicates to the contrary, the following rules shall apply to the context of this FAA:

- (a) Words importing the singular number shall include the plural number and vice versa, and one gender shall include all genders.
- (b) All references herein to particular articles or sections are references to articles or sections of this FAA.
- (c) The captions and headings herein are solely for convenience of reference and shall not constitute a part of this FAA, nor shall they affect its meaning, construction, or effect.
- (d) The terms "hereby", "hereof", "hereto", "herein", "hereunder", and any similar terms as used in this FAA refer to the FAA in its entirety and not the particular article or section of this FAA in which they appear. The term "hereafter" means after and the term "heretofore" means before the date of delivery of this FAA.
- (e) All accounting terms not otherwise defined in this FAA have the meanings assigned to them in accordance with generally accepted accounting principles, and all computations provided for herein shall be made in accordance with generally accepted accounting principles.

ARTICLE II
REPRESENTATIONS

Section 2.01. Representations of the CWFP The CWFP represents and warrants as follows:

- (a) The State is authorized to issue the Bonds in accordance with the Statute and the General Resolution and to use the proceeds thereof to provide funds for the Financial Assistance provided to the Municipality to undertake and complete the Project.
- (b) The CWFP has complied with the provisions of the Statute and has full power and authority to execute and deliver this FAA, consummate the transactions contemplated hereby, and perform its obligations hereunder.
- (c) The CWFP is not in violation of any of the provisions of the Constitution or laws of the State which would affect its powers referred to in the preceding paragraph (b).
- (d) Pursuant to the Statute, the CWFP is authorized to execute and deliver the FAA and to take actions and make determinations that are required of the CWFP under the terms and conditions of the FAA.
- (e) The execution and delivery by the CWFP of this FAA and the consummation of the transactions contemplated by this FAA shall not violate any indenture, mortgage, deed of trust, note, agreement, or other contract or instrument to which the State is a party, or by which it is bound, or, to the best of the CWFP's knowledge, any judgment, decree, order, statute, rule, or regulation applicable to the CWFP; all consents, approvals, authorizations, and orders of governmental or regulatory authorities that are required for the consummation of the transactions contemplated thereby have been obtained.
- (f) To the knowledge of the CWFP, there is no action, suit, proceeding, or investigation at law or in equity, before or by any court, public board, or body, threatened against, pending, or affecting the CWFP, or, to the knowledge of the CWFP, any basis therefor, wherein an unfavorable decision, ruling, or finding would adversely affect the transactions contemplated hereby or which, in any way, could adversely affect the validity of this FAA or any agreement or instrument to which the State is a party and which is used or contemplated for use in consummation of the transactions contemplated by each of the foregoing.

Section 2.02. Representations of the Municipality The Municipality represents, covenants, and warrants as follows:

- (a) The Municipality possesses the legal municipal form of a city under ch. 62, Wis. Stats. The Municipality is located within the State and is a "municipality" within the meaning of the Statute, duly organized and existing under the laws of the State, and has full legal right, power, and authority to:
 - (1) conduct its business and own its properties,
 - (2) enter into this FAA,
 - (3) adopt the Municipal Obligation Resolution,
 - (4) issue and deliver the Municipal Obligations to the CWFP as provided herein, and
 - (5) carry out and consummate all transactions contemplated by each of the aforesaid documents.
- (b) The Municipality's Project is a project that is necessary to prevent the applicant from significantly exceeding an effluent limitation contained in its WPDES Permit (compliance maintenance).
- (c) With respect to the issuance of the Municipal Obligations, the Municipality has complied with the Municipal Obligation Resolution and with all applicable laws of the State.

(d) The governing body of the Municipality has duly approved the execution and delivery of this FAA and the issuance and delivery of the Municipal Obligations in the aggregate principal amount of \$2,323,791 and authorized the taking of any and all action as may be required on the part of the Municipality and its authorized officers to carry out, give effect to, and consummate the transactions contemplated by each of the foregoing.

(e) This FAA and the Municipal Obligations have each been duly authorized, executed, and delivered, and constitute legal, valid, and binding obligations of the Municipality, enforceable in accordance with their respective terms.

(f) To the knowledge of the Municipality, there is no action, suit, proceeding, inquiry, or investigation, at law or in equity, before or by any court, public board, or body, threatened against, pending, or affecting the Municipality, or, to the knowledge of the Municipality, any basis therefor:

(1) affecting the creation, organization, or existence of the Municipality or the title of its officers to their respective offices;

(2) seeking to prohibit, restrain, or enjoin the execution of this FAA or the issuance or delivery of the Municipal Obligations;

(3) in any way contesting or affecting the validity or enforceability of the Municipal Obligation Resolution, the Municipal Obligations, this FAA, or any agreement or instrument relating to any of the foregoing or used or contemplated for use in the consummation of the transactions contemplated by this FAA; or

(4) wherein an unfavorable decision, ruling, or finding could adversely affect the transactions contemplated hereby or by the Municipal Obligation Resolution or the Municipal Obligations.

(g) The Municipality is not in any material respect in breach of or in default under any applicable law or administrative regulation of the State or the United States, any applicable judgment or decree, or any agreement or other instrument to which the Municipality is a party, or by which it or any of its properties is bound, and no event has occurred that, with the passage of time, the giving of notice, or both, could constitute such a breach or default. The execution and delivery of this FAA, the issuance and delivery of the Municipal Obligations, the adoption of the Municipal Obligation Resolution, and compliance with the respective provisions thereof shall not conflict with, or constitute a breach of or default under, any applicable law or administrative regulation of the State or of the United States, any applicable judgment or decree, or any agreement or other instrument to which the Municipality is a party, or by which it or any of its property is bound.

(h) The Municipal Obligations constitute validly-issued, legally-binding special obligations of the Municipality secured as set forth therein.

(i) The resolutions of the Municipality accepting the Financial Assistance and the Municipal Obligation Resolution have been duly adopted by the Municipality and remain in full force and effect as of the date hereof.

(j) The Municipality has full legal right and authority, and all necessary permits, licenses, and approvals (other than such permits, licenses, easements, or approvals that are not by their nature obtainable prior to Substantial Completion of the Project) required as of the date hereof to own the Project, carry on its activities relating thereto, undertake and complete the Project, and carry out and consummate all transactions contemplated by this FAA.

(k) The Municipality represents that it has not made any commitment or taken any action that shall result in a valid claim for any finders' or similar fees or commitments in respect to the issuance and sale of the Municipal Obligations and the making of the Loan under this FAA.

(l) The Project is eligible under s. 281.58(7), Wis. Stats., for financing from the CWFP and the Project Costs are equal to or in excess of the principal amount of the Municipal Obligations. The Project has satisfied the requirements of the State Environmental Review Procedures (SERP) contained in the Regulations. Portions of the Project that are ineligible for financing from the CWFP are listed within the Project Manager Summary Page attached hereto as Exhibit F. The Municipality intends the Project to be eligible under the Statute throughout the term of this FAA.

(m) All amounts shown in Exhibit A of this FAA are costs of a Project eligible for financial assistance from the CWFP under the Statute. All proceeds of any borrowing of the Municipality that have been spent and are being refinanced with the proceeds of the Financial Assistance made hereunder have been spent on eligible Project Costs. All Project Costs are reasonable, necessary, and allocable by the Municipality to the Project under generally accepted accounting principles. None of the proceeds of the Financial Assistance shall be used directly or indirectly by the Municipality as working capital or to finance inventory, as opposed to capital improvements.

(n) The Project is in compliance with all applicable federal, state, and local laws and ordinances (including rules and regulations) relating to zoning, building, safety, and environmental quality. The Municipality has complied with and completed all requirements of DNR necessary to commence construction of the Project prior to the date hereof. The Municipality intends to proceed with due diligence to complete the Project pursuant to Section 4.04 hereof.

(o) The Municipality does not intend to lease the Project or enter into a long-term contract for operation of the Project except as set forth in Exhibit D.

(p) The Municipality shall not take or omit to take any action which action or omission shall in any way cause the proceeds of the Bonds to be applied in a manner contrary to that provided in the General Resolution.

(q) The Municipality has not taken and shall not take any action, and presently knows of no action that any other person, firm, or corporation has taken or intends to take, that would cause interest on the Municipal Obligations to be includable in the gross income of the owners of the Municipal Obligations for federal income tax purposes. The representations, certifications, and statements of reasonable expectation made by the Municipality as referenced in the Municipal Obligation Counsel Opinion and No Arbitrage Certificate are hereby incorporated by this reference as though fully set forth herein.

(r) Other than (1) "preliminary expenditures" as defined in Treas. Regs. 26 CFR 1.150-2 in an amount not exceeding 20% of the principal amount of the Municipal Obligations, or (2) a "de minimis" amount as defined in Treas. Regs. 26 CFR 1.150-2 in an amount not exceeding the lesser of \$100,000 or 5% of the principal amount of the Municipal Obligations, all of the proceeds of the Bonds loaned to the Municipality (other than refunding proceeds, if any) shall be used for Project Costs paid by the Municipality subsequent to a date which is 60 days prior to the date on which the Municipality adopted a reimbursement resolution pursuant to Treas. Regs. 26 CFR 1.150-2 stating its intent to reimburse other funds of the Municipality used to finance the Project, or subsequent to the issuance date of the Municipal Obligations.

(s) The Municipality represents that it has satisfied all the applicable requirements in s. 281.58, Wis. Stats., and ch. NR 162, Wis. Adm. Code.

(t) The Municipality has adopted a rate, charge, or assessment schedule that will generate annually sufficient revenue to pay the principal of and interest on the Municipal Obligations.

(u) The Municipality is in substantial compliance with all conditions, requirements, and terms of financial assistance previously awarded through the federal construction grants program, the Wisconsin Fund construction grants program, and the CWFP.

(v) The Municipality has met all terms and conditions contained within and received DNR approval for the Municipality's Plans and Specifications for the Project described in the definitions hereof.

(w) The Municipality represents that it submitted to DNR a bid tabulation for the Project with a recommendation to DNR for review and concurrence. The actual Substantial Completion date of the Project was May 17, 2019.

(x) The Municipality acknowledges that s. 281.59(11)(b), Wis. Stats., and the General Resolution provide that, if the Municipality fails to repay the Loan when due, the State shall recover amounts due the CWFP by deducting those amounts from any State payments due the Municipality.

This means that the following State payments would have been subject to this deduction:

	Transportation	State-Shared	Total
2017	\$1,545,327.86	\$11,111,393.75	\$12,656,721.61
2018	\$1,745,669.54	\$11,070,318.82	\$12,815,988.36

The amount of State payments anticipated for this year, among others, and as changed or modified from time to time, that are subject to this deduction are:

2019	\$1,830,104.68	\$11,062,747.51	\$12,892,852.19
------	----------------	-----------------	-----------------

These are not the entire amounts of State aid distributed to the Municipality. Other State aid is subject to intercept on failure of the Municipality to make full Loan payments due the CWFP.

The Municipality acknowledges that s. 70.60, Wis. Stats., and the General Resolution provide that, if the Municipality fails to repay the Loan when due, the State shall recover amounts due the CWFP by adding a special charge to the amount of taxes apportioned to and levied upon the county in which the Municipality is located.

(y) The Municipality acknowledges that the State reserves the right upon default by the Municipality hereunder to have a receiver appointed to collect User Fees from the operation of the Municipality's Sewerage System or, in the case of a joint utility system, to bill the users of the Municipality's Sewerage System directly.

(z) The representations of the Municipality in the Application are true and correct as of the date of this FAA and are incorporated herein by reference as if fully set forth in this place.

(aa) There has been no material adverse change in the financial condition or operation of the Municipality or the Project since the submission date of the Application.

(bb) The Municipality acknowledges that it is eligible to receive Financial Assistance in the form of a Loan of \$3,073,791 with Principal Forgiveness of \$750,000 for payment of Project Costs.

ARTICLE III
LOAN PROVISIONS

Section 3.01. Loan Clauses

(a) Subject to the conditions and in accordance with the terms of this FAA, the CWFP hereby agrees to make the Loan and the Municipality agrees to accept the Loan. As evidence of the portion of the Loan made to the Municipality remaining subsequent to the Principal Forgiveness, the Municipality hereby agrees to sell to the CWFP Municipal Obligations in the aggregate principal amount of \$2,323,791. The CWFP shall pay for the Municipal Obligations in lawful money of the United States, which shall be disbursed as provided in this FAA.

(b) Prior to disbursement, Loan proceeds shall be held by the CWFP or by the Trustee for the account of the CWFP. Earnings on undisbursed Loan proceeds shall be for the account of the CWFP. Loan proceeds shall be disbursed only upon submission by the Municipality of disbursement requests and approval thereof as set forth in Section 3.06 hereof.

(c) The Loan shall bear interest at the rate of one and 650/1000ths percent (1.650%) per annum, and interest shall accrue and be payable only on Loan principal amounts actually disbursed on the Municipal Obligations, from the date of disbursement until the date such amounts are repaid or forgiven.

(d) Disbursements of Financial Assistance shall generally be made: first, in the form of a Loan disbursement on the Municipal Obligations, which must be at least 5% of the Municipal Obligation amount or \$50,000, whichever is less; second, in the form of Loan disbursements that include the applicable percentage of Principal Forgiveness up to \$750,000; and third, if the Principal Forgiveness cap has been reached, in the form of Loan disbursements on the Municipal Obligations. Principal Forgiveness will be applied at the time of Loan disbursement.

(e) The Municipal Obligations shall include the Loan Disbursement Table (Exhibit C). The actual dates of disbursements shall be reflected as part of the Municipal Obligations. DOA shall make entries as each disbursement is made and as each principal amount is repaid; the CWFP and the Municipality agree that such entries shall be mutually binding.

(f) Upon Final Completion of the Project, DOA may request that the Municipality issue substitute Municipal Obligations in the aggregate principal amount equal to the outstanding principal balance of the Municipal Obligations.

(g) The Municipality shall deliver, or cause to be delivered, a Municipal Obligation Counsel Opinion to the CWFP concurrently with the delivery of the Municipal Obligations.

Section 3.02. Municipal Obligations Amortization Principal and interest payments on the Municipal Obligations shall be due on the dates set forth in Exhibit B of this FAA. The payment amounts shown on Exhibit B are for informational purposes only and assume the full amount of the Municipal Obligations is disbursed and that the full amount of Principal Forgiveness available is applied to the Loan on December 11, 2019. It is understood that the actual amount of the Municipality's Municipal Obligations payments shall be based on the actual date and amount of disbursements on the Municipal Obligations. Notwithstanding the foregoing or anything in the Municipal Obligations, the Municipal Obligations shall be for no longer than twenty (20) years from the date of this FAA and shall mature and be fully amortized not later than twenty (20) years after the original issue date of the Municipal Obligations. Repayment of principal on the Municipal Obligations shall begin not later than twelve (12) months after the expected or actual Substantial Completion date of the Project.

Section 3.03. Type of Municipal Obligation and Security The Municipality's obligation to meet annual debt service requirements on the Municipal Obligations shall be a revenue obligation evidenced by issuance of revenue bonds pursuant to s. 66.0621, Wis. Stats. The security for the Municipality's obligation shall be a pledge of revenues to be derived from the Municipality's Sewerage System, and the Municipality shall agree that, if revenues from the Sewerage System are insufficient to meet annual debt service requirements, the Municipality shall purchase sewerage services in amounts sufficient to meet annual debt service requirements as provided in and set forth in Section 9 of the Municipal Obligation Resolution. The annual revenues net of all current expenses shall be equal to not less than the annual principal and interest requirements on the Municipal Obligations, any Parity Obligations, and any other debt obligations payable from the revenues of the Sewerage System then outstanding, times the greater of (i) 110 percent or (ii) the highest debt service coverage ratio required with respect to any Parity Obligations or any other debt obligations payable from the revenues of the Sewerage System then outstanding. As of the date of this FAA, the required debt service coverage ratio is 110 percent; however, this percentage is subject to change as outlined in the prior sentence. The Municipal Obligations are also secured as provided in Section 3.08 hereof.

Section 3.04. Other Amounts Payable The Municipality hereby expressly agrees to pay to the CWFP:

(a) such Servicing Fee as the CWFP may impose pursuant to s. 281.58(9)(d), Wis. Stats., which shall be payable in semiannual installments on each interest payment date; such a Servicing Fee shall be imposed upon the Municipality after approval of a future Biennial Finance Plan by the State of Wisconsin Building Commission which contains a Servicing Fee requirement, schedule, and amount; and

(b) the Municipality's allocable share of the Fees and Charges as such costs are incurred. Allocable share shall mean the proportionate share of the Fees and Charges based on the outstanding principal of the Loan.

Amounts paid by the Municipality pursuant to this Section 3.04 shall be deposited in the Expense Fund established pursuant to the General Resolution.

Section 3.05. Sale and Redemption of Municipal Obligations

(a) Municipal Obligations may not be prepaid without the prior written consent of the CWFP. The CWFP has sole discretion to withhold such consent.

(b) The Municipality shall pay all costs and expenses of the CWFP in effecting the redemption of the Bonds to be redeemed with the proceeds of the prepayment of the Municipal Obligations. Such costs and expenses may include any prepayment premium applicable to the CWFP and any investment losses incurred or sustained by the CWFP resulting directly or indirectly from any such prepayment.

(c) Subject to subsection (a), the Municipality may prepay the Municipal Obligations with any settlements received from any third party relating to the design or construction of the Project.

(d) Prepayments of the Municipal Obligations shall be applied pro rata to all maturities of the Municipal Obligations.

Section 3.06. Disbursement of Financial Assistance

(a) Under this FAA, Financial Assistance shall be drawn in the order specified in Section 3.01(d) of this document.

(b) Each disbursement request shall be delivered to DNR. Each request must contain invoices or other evidence acceptable to DNR and DOA that Project Costs for which disbursement is requested have been incurred by the Municipality.

(c) The CWFP, through its agents or Trustee, plans to make disbursements of Financial Assistance on a semimonthly basis upon approval of each disbursement request by DNR and DOA. Such approval by DNR and DOA may require adjustment and corrections to the disbursement request submitted by the Municipality. The Municipality shall be notified whenever such an adjustment or correction is made by DNR or DOA.

(d) Disbursements made to the Municipality are subject to pre- and post-payment adjustments by DNR or DOA.

(1) If the Financial Assistance is not yet fully disbursed, and CWFP funds were previously disbursed for costs not eligible for CWFP funding or not eligible under this FAA, the CWFP shall make necessary adjustments to future disbursements.

(2) If the Financial Assistance is fully disbursed, including disbursements for any costs not eligible for CWFP funding or not eligible under this FAA, the Municipality agrees to repay to the CWFP an amount equal to the non-eligible costs within 60 days of notification by DNR or DOA. The CWFP shall then apply the amount it receives as a Loan prepayment or as a recovery of a Loan disbursement with Principal Forgiveness (if there is no outstanding Loan principal balance available to which the recovery may be applied).

(e) The CWFP or its agent shall disburse Financial Assistance only to the Municipality's account by electronic transfer of funds. The Municipality hereby covenants that it shall take actions and provide information necessary to facilitate these transfers.

(f) Disbursement beyond ninety-five percent (95%) of the Financial Assistance, unless otherwise agreed to by DNR and DOA pursuant to a written request from the Municipality, may be withheld until:

(1) DNR is satisfied that the Project has been completed in accordance with the Plans and Specifications, DNR has approved all change orders relating to the Project, and DNR has determined that the Project is in compliance with the Municipality's WPDES Permit;

(2) the Municipality certifies to DNR its acceptance of the Project from its contractors;

(3) the Municipality certifies in writing to DNR its compliance with applicable federal requirements (certification must be as prescribed on Exhibit G); and

(4) DNR certifies in writing to DOA the Municipality's compliance with all applicable requirements of this FAA.

(g) IRS Regulation 1.148-6(d)(1)(iii) applies to project expenditures. It states, in part, "An issuer must account for the allocation of proceeds to expenditures not later than 18 months after the later of the date the expenditure is paid or the date the project, if any, that is financed by the issue is placed in service".

Section 3.07. Remedies

(a) If the Municipality:

- (1) or any authorized representative is not complying with federal or state laws, regulations, or requirements relating to the Project, and following due notice by DNR the Project is not brought into compliance within a reasonable period of time; or
- (2) is not complying with or is in violation of any provision set forth in this FAA; or
- (3) is not in compliance with the Statute or the Regulations;

then DNR may, until the Project is brought into compliance or the FAA non-compliance is cured to the satisfaction of DNR or DOA, impose one (1) or more of the following sanctions:

- (i) Progress payments or disbursements otherwise due the Municipality of up to 20% may be withheld.
- (ii) Project work may be suspended.
- (iii) DNR may request a court of appropriate jurisdiction to enter an injunction or afford other equitable or judicial relief as the court finds appropriate.
- (iv) Other administrative remedies may be pursued.

(b) If the Municipality fails to make any payment when due on the Municipal Obligations or fails to observe or perform any other covenant, condition, or agreement on its part under this FAA for a period of thirty (30) days after written notice is given to the Municipality by DNR, specifying the default and requesting that it be remedied, the CWFP is provided remedies by law and this FAA. These remedies include, but are not limited to, the following rights:

- (1) Pursuant to s. 281.59(11)(b), Wis. Stats., DOA shall place on file a certified statement of all amounts due the CWFP under this FAA. DOA may collect all amounts due the CWFP by deducting those amounts from any State payments due the Municipality, or add a special charge to the amount of taxes apportioned to and levied upon the county in which the Municipality is located under s. 70.60, Wis. Stats.
- (2) Pursuant to s. NR 162.18(1), Wis. Adm. Code, DNR may: declare the unpaid Loan balance due and immediately payable; increase the interest rate on the unpaid balance of the Loan to the market interest rate in effect on the date the FAA was executed; or immediately terminate the FAA and disburse no additional funds, if the Loan has not been fully disbursed.
- (3) The CWFP may, without giving bond to the Municipality or anyone claiming under it, have a receiver appointed for the CWFP's benefit of the Project and the Municipality's Sewerage System and of the earnings, income, rents, issues, and profits thereof, with such powers as the court making such appointment shall confer. The Municipality hereby irrevocably consents to such appointment.
- (4) In the case of a joint utility system, the CWFP may bill the users of the Municipality's system directly.
- (5) The CWFP may enforce any right or obligation under this FAA, including the right to seek specific performance or mandamus, whether such action is at law or in equity.

Section 3.08. Security for the Municipal Obligations In accordance with the terms of the Municipal Obligation Resolution:

(a) as security for the Municipal Obligations, the Municipality hereby pledges the revenue to be derived from the Municipality's Sewerage System (which is a dedicated source of revenue); and

(b) other than as already pledged to the outstanding Parity Obligations, the Municipality shall not pledge the revenues, except as provided in Section 11 of the Municipal Obligation Resolution, to be derived from the Municipality's User Charge System or other revenues pledged under Section 3.08(a) above, to any person other than the CWFP, unless the revenues pledged to such other person meet the highest debt coverage ratio then applicable to the Municipality.

Section 3.09. Effective Date and Term This FAA shall become effective upon its execution and delivery by the parties hereto, shall remain in full force and effect from such date, and shall expire on such date as the Municipal Obligations shall be discharged and satisfied in accordance with the provisions thereof.

ARTICLE IV
CONSTRUCTION OF THE PROJECT

Section 4.01. Insurance The Municipality agrees to maintain property and liability insurance for the Sewerage System and Project that is reasonable in amount and coverage and that is consistent with prudent municipal insurance practices for the term of this FAA. The Municipality agrees to provide written evidence of insurance coverage to the CFWP upon request at any time during the term of this FAA.

In the event that the Sewerage System or Project is damaged or destroyed, the Municipality agrees to use the proceeds from its insurance coverage either to repay the Financial Assistance or to repair or replace the Sewerage System.

Section 4.02. Construction of the Project The Municipality shall construct the Project, or cause it to be constructed, to Final Completion in accordance with the Application and the Plans and Specifications. The Municipality shall proceed with the acquisition and construction of the Project in conformity with law and with all applicable requirements of governmental authorities having jurisdiction with respect thereto, subject to such modifications of Plans and Specifications that alter the cost of the Project, use of space, scope, or functional layout, as may be previously approved by DNR.

Section 4.03. Performance Bonds The Municipality shall provide, or cause to be provided, performance bonds assuring the performance of the work to be performed under all construction contracts entered into with respect to the Project. All performance bonds required hereunder shall be issued by independent surety companies authorized to transact business in the State.

Section 4.04. Completion of the Project

(a) The Municipality agrees that it shall undertake and complete the Project for the purposes and in the manner set forth in this FAA and in accordance with all federal, state, and local laws, ordinances, and regulations applicable thereto. The Municipality shall, with all practical dispatch and in a sound and economical manner, complete or cause to be completed the acquisition and construction of the Project, and do all other acts necessary and possible to entitle it to receive User Fees with respect to the Project at the earliest practicable time. The Municipality shall obtain all necessary approvals from any and all governmental agencies prior to construction which are requisite to the Final Completion of the Project.

(b) The Municipality shall notify DNR of the Substantial Completion of the Project. The Municipality shall cause to be prepared as-built plans for the Project at or prior to completion thereof.

(c) The Municipality shall take and institute such proceedings as shall be necessary to cause and require all contractors and material suppliers to complete their contracts diligently and in accordance with the terms of the contracts including, without limitation, the correcting of defective work.

(d) Upon Final Completion of the Project in accordance with the Plans and Specifications, the Municipality shall:

(1) certify to DNR its acceptance of the Project from its contractors, subject to claims against contractors and third parties;

(2) complete and deliver to DNR the completed Contract Utilization of Disadvantaged Business Enterprises (DBE) form attached hereto as Exhibit E of this FAA;

(3) prepare and deliver to DNR the completed Federal Requirements Compliance Certification attached hereto as Exhibit G of this FAA;

- (4) obtain all required permits and authorizations from appropriate authorities for operation and use of the Project; and
- (5) submit to DNR an Operation and Maintenance Manual Certification Checklist.

Section 4.05. Payment of Additional Project Costs

(a) In the event of revised eligibility determinations, cost overruns, and amendments exceeding the Financial Assistance amount, the CWFP may allocate additional financial assistance to the Project. The allocation of additional financial assistance may be in the form of a loan at less than the market interest rate, which is established pursuant to the Statute and Regulations. The allocation of additional financial assistance shall depend upon availability of funds, pursuant to the Statute and the Regulations.

(b) In the event that this Financial Assistance is not sufficient to pay the costs of the Project in full, the Municipality shall nonetheless complete the Project and pay that portion of the Project Costs as may be in excess of available Financial Assistance and shall not be entitled to any reimbursement therefore from the CWFP, or the owners of any bonds, except from the proceeds of additional financing which may be provided by the CWFP pursuant to an amendment of this FAA or through a separate FAA.

Section 4.06. No Warranty Regarding Condition, Suitability, or Cost of Project Neither the CWFP, DOA, DNR, nor the Trustee makes any warranty, either express or implied, as to the Project or its condition, or that it shall be suitable for the Municipality's purposes or needs, or that the Financial Assistance shall be sufficient to pay the costs of the Project. Review or approval of engineering reports, facilities plans, Plans and Specifications, or other documents, or the inspection of Project construction by DNR, does not relieve the Municipality of its responsibility to properly plan, design, build, and effectively operate and maintain the Project as required by laws, regulations, permits, and good management practices. DNR or its representatives are not responsible for increased costs resulting from defects in the Plans and Specifications or other Project documents. Nothing in this section prohibits a Municipality from requiring more assurances, guarantees, or indemnity or other contractual requirements from any party performing Project work.

**ARTICLE V
COVENANTS**

Section 5.01. Application of Financial Assistance The Municipality shall apply the proceeds of the Financial Assistance solely to Project Costs.

Section 5.02. Operation and Maintenance; Equipment Replacement Fund

(a) After completion of the Project, the Municipality shall:

(1) at all times operate the Project or otherwise cause the Project to be operated properly and in a sound and economical manner, including proper training of personnel;

(2) maintain, preserve, and keep the Project or cause the Project to be maintained, preserved, and kept in good repair, working order, and condition; and

(3) periodically make, or cause to be made, all necessary and proper repairs, replacements, and renewals so that at all times the operation of the Project may be properly conducted in a manner that is consistent with the requirements of the WPDES Permit. The Municipality shall not, without the approval of DNR, discontinue operation of, sell, or otherwise dispose of the Sewerage System, except for portions of the Sewerage System sold or otherwise disposed of in the course of ordinary repair and replacement of parts so long as this FAA is outstanding.

(b) The Municipality shall establish an equipment replacement fund according to s. NR 162.08, Wis. Adm. Code, and maintain the equipment replacement fund as a separate fund of the Municipality. All User Fees or other revenues specifically collected for the equipment replacement fund shall be deposited into the equipment replacement fund and used for replacement and major repair of equipment necessary for the operation of the Sewerage System, or for unexpected, unbudgeted costs incurred for continuing effective operations of the Sewerage System. Annual deposits shall be made to the equipment replacement fund in amounts sufficient to meet the equipment replacement itemized schedule developed by the Municipality or the percentage schedule option. The Project Manager Summary Page (Exhibit F) shall specify the required annual deposit or required minimum balance/percentage.

Section 5.03. Compliance with Law At all times during construction of the Project and operation of the Sewerage System, the Municipality shall comply with all applicable federal, state, and local laws, ordinances, rules, regulations, permits, and approvals, and with this FAA, including, without limitation, the Statute, the Regulations, and the WPDES Permit.

Section 5.04. Public Ownership The Municipality shall at all times retain ownership of the Project and the Sewerage System of which it is a part.

Section 5.05. Establishment of Project Accounts; Audits

(a) The Municipality shall maintain Project accounts in accordance with generally accepted accounting principles (GAAP), including standards relating to the reporting of infrastructure assets and directions issued by the CWFP. Without any request the Municipality shall furnish to DOA as soon as available, and in any event within one hundred eighty (180) days after the close of each fiscal year, a copy of the audit report for such year and accompanying GAAP-based financial statements for such period, as examined and reported by such independent certified public accountants of recognized standing selected by the Municipality and reasonably satisfactory to DOA, whose reports shall indicate that the accompanying financial statements have been prepared in conformity with GAAP and include standards relating to the reporting of infrastructure assets.

(b) The Municipality shall maintain a separate account that reflects the receipt and expenditure of all CWFP funds for the Project. All Financial Assistance shall be credited promptly upon receipt thereof and shall be reimbursement for or expended only for Project Costs. The Municipality shall: permit any authorized representative of DNR or DOA, or agents thereof, the right to review or audit all records relating to the Project or the Financial Assistance; produce, or cause to be produced, all records relating to any work performed under the terms of this FAA for examination at such times as may be designated by any of them or their authorized representatives; permit extracts and copies of the Project records to be made by them or their authorized representatives; and fulfill information requests by them or their authorized representatives.

Section 5.06. Records The Municipality shall retain all files, books, documents, and records relating to construction of the Project for at least three years following the date of Final Completion of the Project, or for longer periods if necessary due to any appeal, dispute, or litigation. All other files and records relating to the Project shall be retained so long as this FAA remains in effect. As-built plans for the Project shall be retained for the useful life of the Project.

Section 5.07. Project Areas The Municipality shall permit representatives of DNR access to the Project and related records at all reasonable times, include provisions in all contracts permitting such access during construction and operation of the Sewerage System, and allow extracts and copies of Project records to be made by DNR representatives.

Section 5.08. Engineering Inspection The Municipality shall provide competent and adequate inspection of all Project construction under the direction of a professional engineer licensed by the State. The Municipality shall direct such engineer to inspect work necessary for the construction of the Project and to determine whether such work has been performed in accordance with the Plans and Specifications. Any such work not in accordance with the Plans and Specifications shall be remedied, unless such noncompliance is waived by DNR.

Section 5.09. Tax Covenants

(a) The Municipality covenants and agrees that it shall not take any action, or omit to take any action, which action or omission would result in the loss of the exclusion of the interest on any Municipal Obligations now or hereafter issued from gross income for purposes of federal income taxation as that status is governed by Section 103(a) of the Code or any successor provision.

(b) The Municipality shall not take any action, or omit to take any action, which action or omission would cause its Municipal Obligations to be "private activity bonds" within the meaning of Section 141(a) of the Code or any successor provision.

(c) The Municipality shall not directly or indirectly use, or permit the use of, any proceeds of the Bonds (or amounts replaced with such proceeds) or any other funds, or take any action, or omit to take any action, which use or action or omission would cause the Bonds to be "arbitrage bonds" within the meaning of Section 148(a) of the Code or any successor provision. The Municipality hereby further covenants to ensure that all amounts actually received by such Municipality from the CWFP are advanced within three Business Days to the entity submitting the invoice (or to reimburse the Municipality) to which each amount relates, and that all amounts actually received by such Municipality from the CWFP shall not be invested in any interest-bearing account.

(d) The Municipality shall not use (directly or indirectly) the proceeds of the Bonds in any manner that would constitute an "advance refunding" within the meaning of Section 149(d)(5) of the Code or any successor provision.

Section 5.10. User Fee Covenant

(a) The Municipality hereby certifies that it has adopted and shall charge User Fees with respect to the Project in accordance with applicable laws and the Statute and in amounts such that revenues of the Municipality with respect to the Project shall be sufficient, together with other funds available to the Municipality for such purposes, to pay all costs of operating and maintaining the Project in accordance with this FAA, and to pay all amounts due under this FAA and the Municipal Obligations.

(b) The Municipality covenants that it shall adopt and shall adequately maintain for the design life of the Project a system of User Fees with respect to the Project in accordance with s. NR 162.08, Wis. Adm. Code. The Municipality covenants that it shall review the User Charge System at least every two years and shall revise and charge User Fees with respect to the Project such that the revenues and funds described in paragraph (a) shall be sufficient to pay the costs described in paragraph (a).

Section 5.11. Notice of Impaired System The Municipality shall promptly notify DNR and DOA in the case of: any material damage to or destruction of the Project or any part thereof; any actual or threatened proceedings for the purpose of taking or otherwise affecting by condemnation, eminent domain, or otherwise, all or a part of the Sewerage System; any action, suit, or proceeding at law or in equity, or by or before any governmental instrumentality or agency, or any other event which may impair the ability of the Municipality to construct the Project or operate the Sewerage System or set and collect User Fees as set forth in Section 5.10.

Section 5.12. Hold Harmless The Municipality shall save, keep harmless, and defend DNR, DOA, and all their officers, employees, and agents, against any and all liability, claims, and costs of whatever kind and nature for injury to or death of any person or persons, and for loss or damage to any property occurring in connection with or in any way incident to or arising out of the construction, occupancy, use, service, operation, or performance of work in connection with the Project or acts or omissions of the Municipality's employees, agents, or representatives.

Section 5.13. Nondiscrimination Covenant

(a) In connection with the Project, the Municipality agrees to comply with fair employment practices pursuant to subchapter II of ch. 111, Wis. Stats. This provision shall include, but is not limited to, the following: employment, upgrading, demotion, or transfer; recruitment or recruitment advertising; layoff or termination; rates of pay or other forms of compensation; and selection for training, including apprenticeship. The Municipality agrees to post in conspicuous places, available for employees and applicants for employment, notices setting forth the provision of the nondiscrimination clause.

(b) The Municipality shall incorporate the following provision into all Project contracts which have yet to be executed: "In connection with the performance of work under this contract, the contractor agrees not to discriminate against any employee or applicant because of age, race, religion, color, handicap, sex, physical condition, developmental disability, or national origin. The contractor further agrees to comply with fair employment practices pursuant to subchapter II of ch. 111, Wis. Stats. This provision shall include, but not be limited to, the following: employment, upgrading, demotion, or transfer; recruitment or recruitment advertising; layoff or termination; rates of pay or other forms of compensation; and selection for training, including apprenticeship. The contractor further agrees to take affirmative action to ensure equal employment opportunities for persons with disabilities. The contractor agrees to post in conspicuous places, available for employees and applicants for employment, notices setting forth the provisions of the nondiscrimination clause."

Section 5.14. Employees The Municipality or its employees or agents are not employees or agents of the DNR or DOA for any purpose, including worker's compensation.

Section 5.15. Adequate Funds The Municipality shall have sufficient funds available to repay the Municipal Obligations. The Municipality shall have sufficient funds available when construction of the Project is completed to ensure effective operation and maintenance of the Project for purposes constructed.

Section 5.16. Management The Municipality shall provide and maintain competent and adequate management, supervision, and inspection at the construction site to ensure that the completed work conforms with the Plans and Specifications. The Municipality shall furnish progress reports and such other information as DNR may require.

Section 5.17. Reimbursement Any payment of Financial Assistance to the Municipality in excess of the amount determined by final audit to be due the Municipality shall be reimbursed to DOA within 60 days after DNR or DOA provides a notice of overpayment.

Section 5.18. Unpaid User Fees The Municipality shall, to the fullest extent permitted by law, take all actions necessary to certify any unpaid User Fees to the county treasurer in order that such unpaid User Fees will be added as a special charge to the property tax bill of the user.

Section 5.19. Sewer Use Ordinance The Municipality shall comply with the provisions of the Sewer Use Ordinance, as certified in the Application. The Municipality covenants that it shall comply with and enforce all provisions of the Sewer Use Ordinance, as established pursuant to the Statute and Regulations.

Section 5.20. Rebates The Municipality agrees to pay to the CWFP any refunds, rebates, credits, or other amounts received for Project Costs that have already been funded by the CWFP. The CWFP shall then apply the amount it receives as a Loan prepayment or as a recovery of a Loan disbursement with Principal Forgiveness (if there is no outstanding Loan principal balance for the Project).

Section 5.21. Maintenance of Legal Existence

(a) Except as provided in par. (b), the Municipality shall maintain its legal existence and shall not dissolve or otherwise dispose of all or substantially all of its assets and shall not consolidate with or merge into another legal entity.

(b) A Municipality may consolidate with or merge into any other legal entity, dissolve or otherwise dispose of all of its assets or substantially all of its assets, transfer all or substantially all of its assets to another legal entity (and thereafter be released of all further obligation under this FAA and the Municipal Obligations) if:

(1) the resulting, surviving, or transferee legal entity is a legal entity established and duly existing under the laws of Wisconsin;

(2) such resulting, surviving, or transferee legal entity is eligible to receive financial assistance under the Statute;

(3) such resulting, surviving, or transferee legal entity expressly assumes in writing all of the obligations of the Municipality contained in this FAA and the Municipal Obligations and any other documents the CWFP deems reasonably necessary to protect its environmental and credit interests; and

(4) the CWFP shall have consented in writing to such transaction, which consent may be withheld in the absolute discretion of the CWFP.

Section 5.22. Wage Rate Requirements The Municipality represents that it shall comply with Section 513 of the Federal Water Pollution Control Act (33 USC 1372), which requires that all laborers and mechanics

employed by contractors and subcontractors funded directly by or assisted in whole or in part with funding under this Loan shall be paid wages at rates not less than those prevailing on projects of a character similar in the locality as determined by the Secretary of Labor (DOL) in accordance with subchapter IV of chapter 31 of title 40, United States Code.

Section 5.23. Fiscal Sustainability Plan The Municipality has completed all required components of a Fiscal Sustainability Plan and shall maintain the plan at least for the life of the Loan.

Section 5.24. Use of American Iron and Steel The Municipality agrees to comply with requirements for Use of American Iron and Steel contained in section 608 of the Act for products used in the Project which are made primarily of iron and/or steel.

ARTICLE VI
MISCELLANEOUS

Section 6.01. **Notices** All notices, certificates, or other communications hereunder shall be sufficiently given, and shall be deemed given, when hand delivered or mailed by registered or certified mail, postage prepaid, return receipt requested to the addresses set forth below:

- (a) DEPARTMENT OF ADMINISTRATION
OFFICE OF CAPITAL FINANCE
CLEAN WATER FUND PROGRAM
101 EAST WILSON STREET 10TH FLOOR
MADISON WI 53702-0004
OR
PO BOX 7864
MADISON WI 53707-7864
- (b) DEPARTMENT OF NATURAL RESOURCES
BUREAU OF COMMUNITY FINANCIAL ASSISTANCE
101 SOUTH WEBSTER STREET 2ND FLOOR
MADISON WI 53702-0005
OR
PO BOX 7921
MADISON WI 53707-7921
- (c) US BANK CORP TRUST
MATTHEW HAMILTON EP-MN-WS3T
60 LIVINGSTON AVENUE
ST PAUL MN 55101-2292
- (d) CITY OF SHEBOYGAN
828 CENTER AVENUE
SHEBOYGAN WI 53081

Any of the foregoing parties may designate any further or different addresses to which subsequent notices, certificates, or other communications shall be sent, by notice in writing given to the others. Any notice herein shall be delivered simultaneously to DNR and DOA.

Section 6.02. **Binding Effect** This FAA shall be for the benefit of, and shall be binding upon, the CWFP and the Municipality and their respective successors and assigns.

Section 6.03. **Severability** In the event any provision of this FAA shall be held illegal, invalid, or unenforceable by any court of competent jurisdiction, such holding shall not invalidate, render unenforceable, or otherwise affect any other provision hereof.

Section 6.04. **Amendments, Supplements, and Modifications** This FAA may be amended, supplemented, or modified to provide for additional financial assistance for the Project by the CWFP to the Municipality or for other purposes. All amendments, supplements, and modifications shall be in writing between the CWFP (by DNR and DOA acting under authority of the Statute) and the Municipality.

Section 6.05. **Execution in Counterparts** This FAA may be executed in several counterparts, each of which shall be an original, and all of which shall constitute but one and the same instrument.

Section 6.06. **Applicable Law** This FAA shall be governed by and construed in accordance with the laws of the State, including the Statute.

Section 6.07. Benefit of Financial Assistance Agreement This FAA is executed, among other reasons, to induce the purchase of the Municipal Obligations. Accordingly, all duties, covenants, obligations, and agreements of the Municipality herein contained are hereby declared to be for the benefit of, and are enforceable by, the CWFP, its Trustee, or its authorized agent.

Section 6.08. Further Assurances The Municipality shall, at the request of DNR and DOA, authorize, execute, acknowledge, and deliver such further resolutions, conveyances, transfers, assurances, financing statements, and other instruments as may be necessary or desirable for: better assuring, conveying, and providing Principal Forgiveness; and assigning, and confirming the rights, security interests, and agreements concerning Principal Forgiveness or intended to be Principal Forgiveness provided by this FAA and relating to the Municipal Obligations.

Section 6.09. Assignment of Municipal Obligations The Municipality hereby agrees that the Municipal Obligations may be sold, transferred, pledged, or hypothecated to any third party without the consent of the Municipality.

Section 6.10. Covenant by Municipality as to Compliance with General Resolution The Municipality covenants and agrees that it shall comply with the provisions of the General Resolution with respect to the Municipality and that the Trustee and the owners of the Bonds shall have the power and authority provided in the General Resolution. The Municipality further agrees to aid in the furnishing to DNR, DOA, or the Trustee of opinions that may be required under the General Resolution.

Section 6.11. Termination This FAA may be terminated in whole or in part pursuant to one or more of the following:

- (a) The CWFP and the Municipality may enter into an agreement to terminate this FAA at any time. The termination agreement shall establish the effective date of termination of this FAA, the basis for settlement of termination costs, and the amount and date of payment of any sums due either party.
- (b) If the Municipality wishes to unilaterally terminate all or any part of the Project work for which Financial Assistance has been awarded, the Municipality shall promptly give written notice to DNR. If the CWFP determines that there is a reasonable basis for the requested termination, the CWFP may enter into a termination agreement, including provisions for FAA termination costs, effective with the date of cessation of the Project work by the Municipality. If the CWFP determines that the Municipality has ceased work on the Project without reasonable basis, the CWFP may unilaterally terminate Financial Assistance or rescind this FAA.

Section 6.12. Rescission The CWFP may rescind this FAA prior to the first disbursement of any funds hereunder if it determines that:

- (a) there has been substantial non-performance of the Project work by the recipient without justification under the circumstances;
- (b) there is substantial evidence this FAA was obtained by fraud;
- (c) there is substantial evidence of gross abuse or corrupt practices in the administration of the Project;
- (d) the Municipality has failed to comply with the covenants contained in this FAA; or
- (e) any of the representations of the Municipality contained in this FAA were false in any material respect.

IN WITNESS WHEREOF, the CFWP and the Municipality have caused this FAA to be executed and delivered, as of the date and year first written above.

CITY OF SHEBOYGAN

By: _____
Michael J. Vandersteen
Mayor

Attest: _____
Meredith DeBruin
City Clerk

**STATE OF WISCONSIN
DEPARTMENT OF ADMINISTRATION**

By: _____
Authorized Officer

**STATE OF WISCONSIN
DEPARTMENT OF NATURAL RESOURCES**

By: _____
Authorized Officer

EXHIBIT A
PROJECT BUDGET SHEET

CITY OF SHEBOYGAN
 CWFP Project No. 4019-19

	Total Project Costs	Ineligible SDWLP Costs	SDWLP Total Award Amount for this Project
Force Account	\$0	\$0	\$0
Interim Financing Costs	\$0	\$0	\$0
Preliminary Engineering	\$100,000	\$0	\$100,000
Land or Easement Acquisition	\$0	\$0	\$0
Engineering/Construction Mgmt.	\$55,000	\$0	\$55,000
Construction/Equipment	\$2,780,828	\$0	\$2,780,828
Contingency	\$123,893	\$0	\$123,893
Miscellaneous Costs	\$6,070	\$0	\$6,070
SDWLP Closing Costs	\$8,000	\$0	\$8,000
Total	\$3,073,791	\$0	\$3,073,791
Principal Forgiveness Amount (A)			\$750,000
Net SDWLP Loan Amount			\$2,323,791

A = Principal Forgiveness is calculated and awarded up to 25% of the eligible CWFP Total Award Amount for this Project, with a principal forgiveness cap of \$750,000.

City of Sheboygan, Wisconsin
Project # 4019-19 Clean Water Fund Program
Loan Closing Date:

December 11, 2019

Exhibit B-1

<u>Payment Date</u>	<u>Principal Payment</u>	<u>Interest Rate</u>	<u>Interest Payment</u>	<u>Principal & Interest</u>	<u>Bond Year Debt Service</u>	<u>Calendar Year Debt Service</u>
1-May-20	99,018.18	1.650%	14,910.99	113,929.17	113,929.17	
1-Nov-20		1.650%	18,354.38	18,354.38		132,283.55
1-May-21	100,651.98	1.650%	18,354.38	119,006.36	137,360.74	
1-Nov-21		1.650%	17,524.00	17,524.00		136,530.36
1-May-22	102,312.73	1.650%	17,524.00	119,836.73	137,360.73	
1-Nov-22		1.650%	16,679.92	16,679.92		136,516.65
1-May-23	104,000.89	1.650%	16,679.92	120,680.81	137,360.73	
1-Nov-23		1.650%	15,821.91	15,821.91		136,502.72
1-May-24	105,716.91	1.650%	15,821.91	121,538.82	137,360.73	
1-Nov-24		1.650%	14,949.75	14,949.75		136,488.57
1-May-25	107,461.24	1.650%	14,949.75	122,410.99	137,360.74	
1-Nov-25		1.650%	14,063.19	14,063.19		136,474.18
1-May-26	109,234.35	1.650%	14,063.19	123,297.54	137,360.73	
1-Nov-26		1.650%	13,162.01	13,162.01		136,459.55
1-May-27	111,036.72	1.650%	13,162.01	124,198.73	137,360.74	
1-Nov-27		1.650%	12,245.95	12,245.95		136,444.68
1-May-28	112,868.82	1.650%	12,245.95	125,114.77	137,360.72	
1-Nov-28		1.650%	11,314.79	11,314.79		136,429.56
1-May-29	114,731.16	1.650%	11,314.79	126,045.95	137,360.74	
1-Nov-29		1.650%	10,368.25	10,368.25		136,414.20
1-May-30	116,624.22	1.650%	10,368.25	126,992.47	137,360.72	
1-Nov-30		1.650%	9,406.10	9,406.10		136,398.57
1-May-31	118,548.52	1.650%	9,406.10	127,954.62	137,360.72	
1-Nov-31		1.650%	8,428.08	8,428.08		136,382.70
1-May-32	120,504.57	1.650%	8,428.08	128,932.65	137,360.73	
1-Nov-32		1.650%	7,433.92	7,433.92		136,366.57
1-May-33	122,492.90	1.650%	7,433.92	129,926.82	137,360.74	
1-Nov-33		1.650%	6,423.35	6,423.35		136,350.17
1-May-34	124,514.03	1.650%	6,423.35	130,937.38	137,360.73	
1-Nov-34		1.650%	5,396.11	5,396.11		136,333.49
1-May-35	126,568.51	1.650%	5,396.11	131,964.62	137,360.73	
1-Nov-35		1.650%	4,351.92	4,351.92		136,316.54
1-May-36	128,656.89	1.650%	4,351.92	133,008.81	137,360.73	
1-Nov-36		1.650%	3,290.50	3,290.50		136,299.31
1-May-37	130,779.73	1.650%	3,290.50	134,070.23	137,360.73	
1-Nov-37		1.650%	2,211.57	2,211.57		136,281.80
1-May-38	132,937.59	1.650%	2,211.57	135,149.16	137,360.73	
1-Nov-38		1.650%	1,114.83	1,114.83		136,263.99
1-May-39	135,131.06	1.650%	1,114.83	136,245.89	137,360.72	136,245.89
Totals	2,323,791.00		399,992.05	2,723,783.05	2,723,783.05	2,723,783.05
			Net Interest Rate	1.6500%		
			Bond Years	24,241.9398		
			Average Life	10.4321		

The above schedule assumes full disbursement of the loan on the loan closing date.
 10-Nov-19 Wisconsin Department of Administration

Loan Payment Schedule Comments

The following Loan Repayment Schedule is a hypothetical payment schedule that assumes all of the loan proceeds are drawn on the loan closing date. Since the Environmental Improvement Fund (“EIF”) loans are generally construction loans, the actual total amount of the loan disbursements, as well as the timing of the loan disbursements, will typically not be known until the construction project is complete. At the time that the last draw on your loan is made, the actual loan repayment schedule can be determined for the remainder of the loan term. Your municipality is only charged interest on the amount of the loan that is disbursed and the calculation is based on the number of days that the municipality has use of the money.

Please look over the following loan payment schedule so that you are aware of the dates when the interest payments start and when the principal payments will start. These payment dates are set in the bond/note that is the collateral for your EIF loan. A final loan payment schedule will be provided to you when DNR notifies DOA that the project is complete and the project is ready to be “closed-out”. A Loan Payment Schedule based on year-to-date disbursements may be obtained by your municipality or your auditor for planning or reporting purposes. To obtain a Loan Payment Schedule based on year-to-date loan disbursements, please go to:

<http://www.eif.doa.wi.gov>

and select the report titled “Loan Payment Schedule”.

If you have any questions on the following hypothetical loan payment schedule, please call Katherine Miller at 608-266-2305.

Other loan accounts reports are also available at the above website. Updated information is available on the website the day following a loan disbursement, a loan payment or other financial transaction that changes the loan balance.

Your EIF Loan Information is Available On-line!

The Environmental Improvement Fund has your loan/grant account information available on-line titled "EIF WebReports" at:

<http://www.eif.doa.wi.gov>

The following EIF WebReports are available:

Auditor Verification Report – This report will provide the information typically requested by Audit Firms at the end of each calendar year as part of their regular verification process for annual Financial Audits. This report is available for completed calendar years.

Loan Account History – This report will show loan disbursements, principal repayments and the loan balance as of the date that you select for the report.

Loan Payment Schedule – This report will show the scheduled principal and interest payments as of the date that you select for the report.

Payment History – This report will show the principal and interest payments that have already been made on the loan as of the date that you select for the report.

Disbursement History – This report will show both loan **and grant** disbursements that have been made for the selected project as of the date that you select for the report.

Only one WebReport can be run at a time. However, if your municipality has multiple EIF projects, one WebReport can be run for all the municipality's projects at one time. This can be done by choosing "All" where asked to select a project.

If you need to run multiple reports for a project, just close the window after running the first report, then you will be back at the page where you can select a second WebReport without having to again select the project number or re-enter the "as of" date.

At the top of the WebReports page, there is a link to "Notes about Running EIF WebReports". Information about a number of fine points related to the WebReports is contained in this section.

The WebReports will be available 24 hours a day unless the DOA server is down for maintenance or repairs. The WebReports are set-up so that you can either view the information on your computer screen, print-out a copy of the WebReport, or export the file in Excel format.

EXHIBIT C

FORM OF LOAN DISBURSEMENT TABLE

<u>Amount of Disbursement</u>	<u>Date of Disbursement</u>	<u>Series of Bonds</u>	<u>Principal Repaid</u>	<u>Principal Balance</u>
\$ _____	_____	_____	\$ _____	\$ _____
\$ _____	_____	_____	\$ _____	\$ _____
\$ _____	_____	_____	\$ _____	\$ _____
\$ _____	_____	_____	\$ _____	\$ _____
\$ _____	_____	_____	\$ _____	\$ _____
\$ _____	_____	_____	\$ _____	\$ _____
\$ _____	_____	_____	\$ _____	\$ _____
\$ _____	_____	_____	\$ _____	\$ _____
\$ _____	_____	_____	\$ _____	\$ _____
\$ _____	_____	_____	\$ _____	\$ _____

EXHIBIT D

OPERATING CONTRACTS

As of the date of this FAA, the Municipality does not have any contracts with private entities or other governmental units to operate its Sewerage System.

EXHIBIT E

ENVIRONMENTAL IMPROVEMENT FUND
CONTRACT UTILIZATION OF DISADVANTAGED BUSINESS ENTERPRISES (DBE)

MANDATORY PROJECT CLOSEOUT DOCUMENT

Note: This form is authorized by s. NR 162.14(4)(b)4, Wis. Adm. Code. Receipt of this completed form by the Department is mandatory prior to receiving a final disbursement. The information printed on this form is taken from the completed DBE Subcontractor Utilization Form (EPA Form 6100-4). Any changes or additions made to the list of prime contractors and DBE subcontractors during the construction must be reflected on this form at closeout. Personal information collected on this form will be used for program administration and must be made available to requesters as required by Wisconsin Open Records Law (s. 19.31 – 19.39, Wis. Stats.).

Municipality Name: City of Sheboygan	Project Number: 4019-19	Loan/Grant Amount: \$ 3,073,791
Project Description: Replace medium voltage switchgear at WWTP		
Did the municipality satisfy the DBE requirements? <input checked="" type="checkbox"/> Yes <input type="checkbox"/> No (If no, refer to Project Manager Summary Page of the FAA.)		

Construction/Equipment/Supplies Contracts	Indicate DBE Type	Type of Product or Service *	Contract Estimate \$	Actual Amount Paid to DBE Firm
				Municipality Completes at Project Closeout
Prime: Altmeyer Electric, Inc.	<input type="checkbox"/> MBE <input type="checkbox"/> WBE <input type="checkbox"/> Other <input checked="" type="checkbox"/> N/A	Electrical	\$2,780,828	
Sub: Price & Sons	<input checked="" type="checkbox"/> MBE <input type="checkbox"/> WBE <input type="checkbox"/> Other	Electrical	\$90,000	
Sub:	<input type="checkbox"/> MBE <input type="checkbox"/> WBE <input type="checkbox"/> Other			
Sub:	<input type="checkbox"/> MBE <input type="checkbox"/> WBE <input type="checkbox"/> Other			
Sub:	<input type="checkbox"/> MBE <input type="checkbox"/> WBE <input type="checkbox"/> Other			
Sub:	<input type="checkbox"/> MBE <input type="checkbox"/> WBE <input type="checkbox"/> Other			
Prime:	<input type="checkbox"/> MBE <input type="checkbox"/> WBE <input type="checkbox"/> Other <input type="checkbox"/> N/A			
Sub:	<input type="checkbox"/> MBE <input type="checkbox"/> WBE <input type="checkbox"/> Other			
Sub:	<input type="checkbox"/> MBE <input type="checkbox"/> WBE <input type="checkbox"/> Other			
Sub:	<input type="checkbox"/> MBE <input type="checkbox"/> WBE <input type="checkbox"/> Other			
Sub:	<input type="checkbox"/> MBE <input type="checkbox"/> WBE <input type="checkbox"/> Other			
Sub:	<input type="checkbox"/> MBE <input type="checkbox"/> WBE <input type="checkbox"/> Other			
Prime:	<input type="checkbox"/> MBE <input type="checkbox"/> WBE <input type="checkbox"/> Other <input type="checkbox"/> N/A			
Sub:	<input type="checkbox"/> MBE <input type="checkbox"/> WBE <input type="checkbox"/> Other			
Sub:	<input type="checkbox"/> MBE <input type="checkbox"/> WBE <input type="checkbox"/> Other			
Sub:	<input type="checkbox"/> MBE <input type="checkbox"/> WBE <input type="checkbox"/> Other			
Sub:	<input type="checkbox"/> MBE <input type="checkbox"/> WBE <input type="checkbox"/> Other			
Sub:	<input type="checkbox"/> MBE <input type="checkbox"/> WBE <input type="checkbox"/> Other			
				Total MBE \$ _____
				Total WBE \$ _____
				Total Other \$ _____

Professional/Technical Services Contracts	Indicate DBE Type	Type of Product or Service *	Contract Estimate \$	Actual Amount Paid to DBE Firm
				Municipality Completes at Project Closeout
Prime: Strand Associates	<input type="checkbox"/> MBE <input type="checkbox"/> WBE <input type="checkbox"/> Other <input checked="" type="checkbox"/> N/A	Engineering	\$132,000	
Sub:	<input type="checkbox"/> MBE <input type="checkbox"/> WBE <input type="checkbox"/> Other			
Sub:	<input type="checkbox"/> MBE <input type="checkbox"/> WBE <input type="checkbox"/> Other			
Prime:	<input type="checkbox"/> MBE <input type="checkbox"/> WBE <input type="checkbox"/> Other <input type="checkbox"/> N/A			
Sub:	<input type="checkbox"/> MBE <input type="checkbox"/> WBE <input type="checkbox"/> Other			
Sub:	<input type="checkbox"/> MBE <input type="checkbox"/> WBE <input type="checkbox"/> Other			
Prime:	<input type="checkbox"/> MBE <input type="checkbox"/> WBE <input type="checkbox"/> Other <input type="checkbox"/> N/A			
Sub:	<input type="checkbox"/> MBE <input type="checkbox"/> WBE <input type="checkbox"/> Other			
Sub:	<input type="checkbox"/> MBE <input type="checkbox"/> WBE <input type="checkbox"/> Other			
				Total MBE \$ _____
				Total WBE \$ _____
				Total Other \$ _____

*Type of Product or Service examples: landscaping, trucking, supplies, equipment, paving, concrete, plumbing, electrical, excavating, testing, design, etc.

Name of Person Completing This Form	Email Address	Phone Number
-------------------------------------	---------------	--------------

Certification		
I certify that, to the best of my knowledge and belief, the information provided on this form is complete and correct.		
Name/Title of Municipal Official	Signature	Date Signed

EXHIBIT F

PROJECT MANAGER SUMMARY PAGE

CITY OF SHEBOYGAN
CWFP Project No. 4019-19

1. **Project Description:** This Project will replace aging electrical switch gear at the wastewater treatment plant. New gear that is designed to modern electrical standards will be installed.
2. **Ineligible Costs:** No ineligible costs were identified in the review of this Project. If the Department identifies ineligible costs as the Project progresses, the Department will notify the Municipality.
3. **Contingency Allowance:** The Contingency allowance of \$123,893 is five percent of the amount of uncompleted construction work adjusted for CME reviewed change orders. The Municipality must obtain CME approval of change orders prior to requesting reimbursement.

Base contingency (Uncompleted construction work x 5%)	\$139,042
--	-----------

Contractor	Contract No.	CO No.	
Altmeyer Electric, Inc.	1-2017	1	\$(15,149)

Total Contingency Allowance	\$123,893
-----------------------------	-----------

4. **Equipment Replacement Fund:** The Municipality shall establish an equipment replacement fund according to s. NR 162.08, Wis. Adm. Code, and maintain the equipment replacement fund as a separate fund of the Municipality. Annual deposits shall be made to the equipment replacement fund in amounts sufficient to meet the equipment replacement schedule developed by the Municipality. Based on review of the equipment replacement fund information in the CWFP application, the annual deposit is estimated at \$896,050.
5. **DBE Good Faith Efforts:** The Municipality and their prime contractor made good faith efforts to obtain DBE participation in the Project. The prime contractor is subcontracting with one MBE, Price & Sons Inc., for approximately \$90,000 of work.
6. **Use of American Iron and Steel:** This Project is subject to the Use of American Iron and Steel (UAIS) requirements of section 608 of the Act.
7. **Fiscal Sustainability Plan:** The Municipality certified to DNR that a Fiscal Sustainability Plan (FSP) that meets the requirements of section 603(d)(1)(E) of the Act has been developed and that the plan will be maintained at least for the life of the Loan.
8. **Miscellaneous Costs:** \$6,070 of Project Costs are included on the Miscellaneous line of the budget (Exhibit A) for geotechnical services.

EXHIBIT G

FEDERAL REQUIREMENTS COMPLIANCE CERTIFICATION

[Prepare on Municipal Letterhead at Project Completion and Closeout]

The undersigned officials of the City of Sheboygan (the "Municipality") hereby certify that, for all expenditures made for construction of DNR Project No. 4019-19 (the "Project"), the Municipality has met the prevailing wage rate requirements of the Davis-Bacon Act.

The Municipality further certifies that, after taking into account any national or project-specific waivers approved by the U.S. Environmental Protection Agency, DNR Project No. 4019-19 has met the requirements for the Use of American Iron and Steel contained in section 608 of the Federal Water Pollution Control Act, as amended.

The Municipality further certifies that a Fiscal Sustainability Plan meeting the requirements of section 603(d)(1)(E) of the Federal Water Pollution Control Act, as amended, has been completed for the treatment works and that the plan will be maintained at least for the life of the CWFP Loan for the Project.

The above certification is determined, after due and diligent investigation, to be true and accurate to the best of my knowledge.

By: _____
[Name of Municipal Official or
Authorized Representative]
[Title]

Dated as of: _____

Attest: _____
[Name of Clerk or Secretary]
[Title]

Dated as of: _____

Clean Water Fund Program Project No. 4019-19
City of Sheboygan
Replace Medium Voltage Switchgear at WWTP
Financial Assistance Agreement – Closing Schedule

By November 11, 2019:

- Department of Natural Resources (DNR) project manager distributes Financial Assistance Agreement (FAA) to Department of Administration (DOA) for review.

By November 18, 2019:

- Quarles & Brady, LLP distributes draft Municipal Obligation Resolution and other bond documents to the City of Sheboygan and DOA for review. Project manager mails FAA to municipality.

On December 2, 2019:

- Municipality holds properly noticed meeting at which time:
 1. Municipal Obligation Resolution is adopted.
 2. Bond related documents are signed by municipal officials.
 3. DNR FAA is signed by municipal officials.

NOTE: Most documents must be signed by Highest Elected Official & Clerk/Secretary and some documents must have municipal seal applied. Do not sign any Exhibits.

By December 3, 2019:

- 1. Municipality returns FAA via overnight delivery to DNR Project Manager, Noah Balgooyen, for countersigning by DNR.
 2. Municipality delivers signed & sealed Resolution & other bond documents via overnight delivery to Quarles & Brady, LLP.

By December 9, 2019:

- Quarles & Brady, LLP sends final signed and sealed bond documents and legal opinion to DOA.

December 11, 2019:

- Loan closing day. Quarles & Brady, LLP contacts DOA to confirm closing and DOA wire transfers the first disbursement to municipal bank account.

Clean Water Fund Program Project No. 4019-19
City of Sheboygan
Replace Medium Voltage Switchgear at WWTP
Financial Assistance Agreement Summary
Distribution Sheet

FINANCIAL ASSISTANCE INFO

Total Project Amount: \$3,073,791

Principal Forgiveness Amount: \$750,000 Net CWFP Loan Amount: \$2,323,791

Non-CWFP Grant Funding: \$0 Internal Funding: \$0 Non-CWFP Loan Funding: \$0

Pledge: Sewer Revenue Bonds Lien Priority: Senior-Parity

Composite Interest Rate: 1.65%

DOCUMENT INFO

Date of Municipal Obligation Resolution – December 2, 2019

CLOSING INFO

Refinancing: \$0

Estimated Reimbursement: \$2,712,818.24

DISTRIBUTION

Department of Natural Resources

Noah Balgooyen
Bureau of Community Financial Assistance
101 South Webster Street, 2nd Floor
PO Box 7921
Madison WI 53707-7921
608-264-8841
noah.balgooyen@wisconsin.gov

Department of Administration

Katherine Miller
State of Wisconsin DOA Capital Finance Office
101 East Wilson Street, 10th Floor
PO Box 7864
Madison WI 53707-7864
608-266-2305
Katherinec.miller@wisconsin.gov

Municipality

Steven Jossart
City of Sheboygan
828 Center Avenue
Sheboygan WI 53081
920-459-3361
steve.jossart@sheboyganwwtp.com

Engineering Firm

Philip Severson
Strand Associates, Inc.
910 West Wingra Drive
Madison WI 53715-1943
608-251-4843
phil.severson@strand.com

Municipal Bond Counsel

Rebecca Speckhard
Quarles & Brady, LLP
411 East Wisconsin Avenue
Milwaukee WI 53202-4497
414-277-5000
rebecca.speckhard@quarles.com

Financial Advisor

Carol Wirth
Wisconsin Public Finance Professionals, LLC
1020 N Broadway, Suite G9
Milwaukee WI 53202
414-434-9644
cawirth@wipublicfinance.com

III

Res. No. _____ - 19 - 20. By Alderpersons Donohue and Bohren.
November 18, 2019.

A RESOLUTION authorizing the appropriate City Officials to execute an engagement letter with Quarles & Brady LLP to serve as special tax counsel with regard to a proposed lease financing for the acquisition of garbage and recycling carts.

RESOLVED: That the appropriate City officials are hereby authorized to enter into the attached engagement letter with Quarles & Brady LLP to serve as special tax counsel for the City of Sheboygan regarding a proposed lease financing for the acquisition of garbage and recycling carts.

Finance Personnel

I HEREBY CERTIFY that the foregoing Resolution was duly passed by the Common Council of the City of Sheboygan, Wisconsin, on the _____ day of _____, 20____.

Dated _____ 20____. _____, City Clerk

Approved _____ 20____. _____, Mayor



411 East Wisconsin Avenue
Suite 2350
Milwaukee, Wisconsin 53202-4426
414.277.5000
Fax 414.271.3552
www.quarles.com

Attorneys at Law in
Chicago
Indianapolis
Madison
Milwaukee
Minneapolis
Naples
Phoenix
Scottsdale
Tampa
Tucson
Washington, D.C.

November 7, 2019

VIA EMAIL

Mr. Marty Halverson
Finance Director
City of Sheboygan
City Hall
828 Center Avenue
Sheboygan, WI 53081-4442

**Scope of Engagement Re: Proposed City of Sheboygan (the "City") Lease
Financing (the "Financing")**

Dear Marty:

We are pleased to be working with you as the City's special tax counsel in connection with the Financing.

The purpose of this letter is to set forth the role we propose to serve and responsibilities we propose to assume as special tax counsel in connection with the above-referenced Financing. If you have any questions about this letter or the services we will provide, or if you would like to discuss modifications, please contact me.

Role of Special Tax Counsel

Our special tax counsel engagement is a limited, special counsel engagement. Special tax counsel is engaged as a recognized independent expert whose primary responsibility is to render an objective legal opinion with respect to the taxability of interest on the payments due under the Financing.

As special tax counsel we will: examine applicable law; prepare and comment on documents; consult with the parties to the transaction, prior to the issuance of the Financing; review certified proceedings; and undertake such additional duties as we deem necessary to render the special tax counsel opinion described below. As special tax counsel, we do not advocate the interests of the City or any other party to the transaction. We assume that the

Mr. Marty Halverson
November 7, 2019
Page 2

parties to the transaction will retain such counsel as they deem necessary and appropriate to represent their interests in this transaction.

Subject to the completion of proceedings to our satisfaction, we will render our opinion that the interest component of the rental payments due under the Financing will be excludable from gross income for federal income tax purposes (subject to certain limitations which may be expressed in the opinion).

The special tax counsel opinion will be executed and delivered by us in written form on the date the Financing closes (the "Closing") and will be based on facts and law existing as of its date.

Upon delivery of the opinion, our responsibilities as special tax counsel will be concluded with respect to this financing; specifically, but without implied limitation, we do not undertake (unless separately engaged) to provide any ongoing advice to the City or any other party concerning any actions necessary to assure that interest paid on the payments due under the Financing will continue to be excluded from gross income for federal income tax purposes, or participating in an Internal Revenue Service or other regulatory body survey or investigation regarding or audit of the Financing.

In rendering the opinion, we will rely upon the certified proceedings and other certifications of public officials and other persons furnished to us without undertaking to verify the same by independent investigation. As to state law matters, including the validity and enforceability of the Financing, we will rely on the opinion of the City Attorney.

The services we will provide under this engagement are strictly limited to legal services. We are neither qualified nor engaged to provide financial advice and we will make no representation about the desirability of the proposed plan of finance, the feasibility of the projects financed or refinanced by the Financing, or any related matters.

Diversity of Practice; Consent to Unrelated Engagements

Because of the diversity of practice of our firm, members of our firm other than those who serve you may be asked to represent other clients who have dealings with the City regarding such matters as zoning, licensing, land division, real estate, property tax or other matters which are unrelated to our special tax counsel work. Ethical requirements sometimes dictate that we obtain the City's consent to such situations even though our service to you is limited to the specialized area of special tax counsel. We do not represent you in legal matters regularly, although we may be called upon for special representation occasionally, and our special tax counsel work does not usually provide us information that will be disadvantageous to you in other representations. We do not believe that such representations of others would adversely

Mr. Marty Halverson
November 7, 2019
Page 3

affect our relationship with you, and we have found that local governments generally are agreeable to the type of unrelated representation described above. We would like to have an understanding with you that the City consents to our firm undertaking representations of this type. Your approval of this letter will serve to confirm that the City has no objection to our representation of other clients who have dealings with the City, unrelated to the borrowing and finance area or any other area in which we have agreed to serve it. If you have any questions or would like to discuss this consent further, please call us.

Fees

Based upon: (i) our current understanding of the terms, structure, size and schedule of the financing, (ii) the duties we will undertake pursuant to this letter, (iii) the time we anticipate devoting to the Financing, and (iv) the responsibilities we assume, we estimate that our fee will be \$5,000. It is our understanding that our fee will be paid at the time of the Closing.

If, for any reason, the financing is not consummated or is completed without the rendition of our opinion as special tax counsel, we will expect to be compensated at our normal hourly rates for time actually spent, plus out-of-pocket expenses. We customarily do not submit any statement until the Closing unless there is a substantial delay in completing the financing.

Terms of Engagement

Either the City or Quarles & Brady may terminate the engagement at any time for any reason by written notice, subject on our part to applicable rules of professional conduct. If the City terminates our services, the City is responsible for promptly paying us for all fees, charges, and expenses incurred before the date we receive termination. We reserve the right to withdraw from representing the City if, among other things, the City fails to honor the terms of this engagement letter – including the City's failing to pay our bills, the City's failing to cooperate or follow our advice on a material matter, or our becoming aware of any fact or circumstance that would, in our view, render our continuing representation unlawful or unethical.

Unless previously terminated, our representation will terminate when we send to the City (or its representative) our final bill for services rendered. If the City requests, we will promptly return the City's original papers and property to you, consistent with our need to ensure payment of any outstanding bills. We may retain copies of the documents. We will keep our own files, including attorney work product, pertaining to our representation of the City. For various reasons, including the minimization of unnecessary storage expenses, we may destroy or otherwise dispose of documents and materials a reasonable time after termination of the engagement.

Mr. Marty Halverson
November 7, 2019
Page 4

City Responsibilities

We will provide legal counsel and assistance to the City in accordance with this letter and will rely upon information and guidance the City and its personnel provide to us. We will keep the City reasonably informed of progress and developments, and respond to the City's inquiries. To enable us to provide the services set forth in this letter, the City will disclose fully and accurately all facts and keep us apprised of all developments relating to this matter. The City agrees to pay our bills for services and expenses in accordance with this engagement letter. The City will also cooperate fully with us and be available to attend meetings, conferences, hearings and other proceedings on reasonable notice, and stay fully informed on all developments relating to this matter.

Limited Liability Partnership

Our firm is a limited liability partnership ("LLP"). Because we are an LLP, no partner of the firm has personal liability for any debts or liabilities of the firm except as otherwise required by law, and except that each partner can be personally liable for his or her own malpractice and for the malpractice of persons acting under his or her actual supervision and control. As an LLP we are required by our code of professional conduct to carry at least \$10,000,000 of malpractice insurance; currently, we carry coverage with limits substantially in excess of that amount. Please call me if you have any questions about our status as a limited liability partnership.

Mr. Marty Halverson
November 7, 2019
Page 5

Conclusion and Request for Signed Copy

If the foregoing terms of this engagement are acceptable to you, please so indicate by returning a copy of this letter dated and signed by an appropriate officer, retaining the original for your files. If we do not hear from you within thirty (30) days, we will assume that these terms are acceptable to you, but we would prefer to receive a signed copy of this letter from you.

We are looking forward to working with you and the City in this regard.

Very truly yours,

QUARLES & BRADY LLP

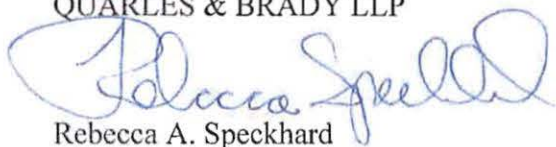

Rebecca A. Speckhard

RAS:DRG

cc: Thomas Cameron, Esq. (via email)
Mr. David Groose (via email)

Accepted and Approved:

CITY OF SHEBOYGAN

By: _____

Its: _____
Title

Date: _____

III

Res. No. - 19 - 20. By Alderpersons Wolf and Donohue.
November 18, 2019.

A RESOLUTION authorizing the mayor to sign a letter to the United States Secretary of State consenting to continued initial refugee resettlement in Sheboygan pursuant to Executive Order 13888.

WHEREAS, the City of Sheboygan has a long history of participating in refugee resettlement with widespread community support for that participation; and

WHEREAS, refugee resettlement has significantly enriched our community, state, and nation, both culturally and economically; and

WHEREAS, the President has issued an Executive Order directing that within 90 days of the date of the order, the Secretary of State and the Secretary of Health and Human Services shall resettle refugees only in areas where both state and local governments consent in writing to the resettlement of refugees in their respective areas; and

WHEREAS, the State of Wisconsin has consented to resettlement, and Sheboygan County is also being requested to so consent; and

WHEREAS, authorizing the mayor to sign a letter consenting to continued initial refugee resettlement in no way represents an opinion by the council or any city official regarding the validity of Executive Order 13888 as a lawful exercise of Presidential authority in light of federal legislation governing refugee resettlement, specifically Title 8, Chapter 12, Subchapter IV of the United States Code.

NOW THEREFORE BE IT RESOLVED that the Mayor is hereby authorized to consent to continued initial refugee resettlement in Sheboygan per the terms of Executive Order 13888 and sign the attached letter expressing such consent.

JHP

BE IT FURTHER RESOLVED that the Common Council hereby encourages the Sheboygan County Board of Supervisors to authorize its County Administrator to also consent to continued initial refugee resettlement in Sheboygan County and instructs the Clerk to send a copy of this resolution and the attached letter to the County Administrator and the Chair of the County Board.

I HEREBY CERTIFY that the foregoing Resolution was duly passed by the Common Council of the City of Sheboygan, Wisconsin, on the _____ day of _____, 20____.

Dated _____ 20____. _____, City Clerk

Approved _____ 20____. _____, Mayor

Secretary Michael R. Pompeo
U.S. Department of State
2201 C Street NW
Washington DC, 20520

December 3, 2019

Dear Secretary Pompeo:

This letter is in reference to Executive Order 13888, "*On Enhancing State and Local Involvement in Resettlement.*"

As Mayor of the City of Sheboygan, and with the support of the City of Sheboygan Common Council, I consent to initial refugee resettlement in Sheboygan as per the terms of the Executive Order.

Sincerely,

Michael Vandersteen, Mayor

CC:
Principal Deputy Assistant Secretary Carol T. O'Connell
Bureau of Population, Refugees, and Migration
U.S. Department of State

III

Res. No. _____ - 19 - 20. By Alderpersons Wolf and Sorenson.
November 18, 2019.

A RESOLUTION authorizing the Department of Public Works to turn off power to the City of Sheboygan Municipal Armory/Auditorium due to the hazardous conditions present within the building that pose dangers to maintenance employees and others needing to access the building.

WHEREAS, there are currently very high water levels in both Lake Michigan and the Sheboygan River; and

WHEREAS, if the electricity is left on at the City of Sheboygan Municipal Armory/Auditorium (the "Armory"), there is a concern that the high water levels coupled with the presence of running electricity creates a risk to the safety of maintenance employees or others who may need to access the Armory to deal with any other issues at the Armory; and

WHEREAS, given the ongoing structural issues at the Armory, it is likely that during this period of high water levels, maintenance employees or others will need to enter the Armory.

NOW, THEREFORE, BE IT RESOLVED: In the interest of safety, the Department of Public Works is authorized to turn off power to the Armory to reduce the danger to anyone who needs to enter the Armory to deal with any issues at the Armory.

Public Works

I HEREBY CERTIFY that the foregoing Resolution was duly passed by the Common Council of the City of Sheboygan, Wisconsin, on the _____ day of _____, 20____.

Dated _____, 20____. _____, City Clerk

Approved _____, 20____. _____, Mayor

VIII

R. C. No. _____ - 19 - 20. By PUBLIC WORKS COMMITTEE. November 18, 2019.

Your Committee to whom was referred R. C. No. 177-19-20 by Public Works Committee and Res. No. 104-19-20 by Alderpersons Wolf and Sorenson authorizing executing a storm sewer easement (Eighth Street Investments, LLC); recommends adopting the Resolution.

reg.

_____ Committee

I HEREBY CERTIFY that the foregoing Committee Report was duly accepted and adopted by the Common Council of the City of Sheboygan, Wisconsin, on the _____ day of _____, 20____.

Dated _____ 20____. _____, City Clerk

Approved _____ 20____. _____, Mayor

IV

5.3

R. C. No. 177 - 19 - 20. By PUBLIC WORKS COMMITTEE. November 4, 2019.

Your Committee to whom was referred Res. No. 104-19-20 by Alderpersons Wolf and Sorenson authorizing executing a storm sewer easement (Eighth Street Investments, LLC); recommends adopting the Resolution.

Public Works
Res adopted

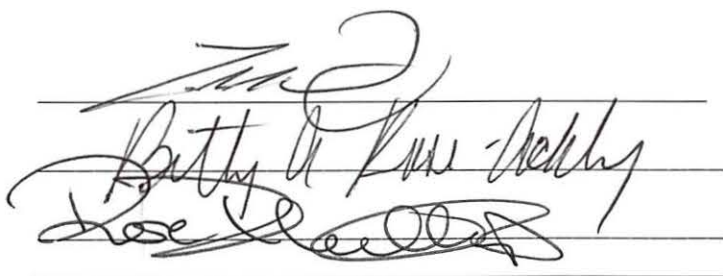
Betty A. Ann Kelly

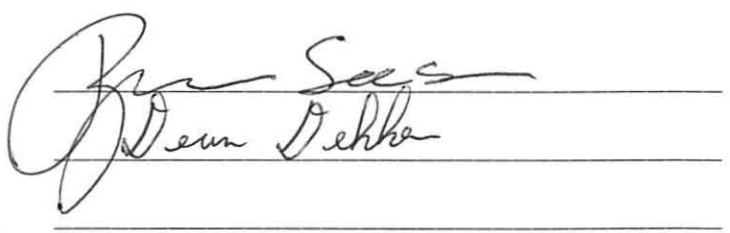
Dean Dekker

Committee

I HEREBY CERTIFY that the foregoing Committee Report was duly accepted and adopted by the Common Council of the City of Sheboygan, Wisconsin, on the _____ day of _____, 20____.

Dated _____ 20____. _____, City Clerk

Approved _____ 20____. _____, Mayor

III

5.4

Res. No. 104 19 - 20. By Alderpersons Wolf and Sorenson. October 21, 2019.

A RESOLUTION authorizing executing a storm sewer easement.

RESOLVED: That the Mayor and City Clerk are hereby authorized and directed to execute the attached Storm Sewer Easement for the City to construct a storm sewer at the following location:

Eighth Street Investments, LLC, 604 North 8th Street, Sheboygan, WI

Public Works
adopt



I HEREBY CERTIFY that the foregoing Resolution was duly passed by the Common Council of the City of Sheboygan, Wisconsin, on the _____ day of _____, 20____.

Dated _____ 20____. _____, City Clerk

Approved _____ 20____. _____, Mayor

Document Number

Document Title

STORM SEWER EASEMENT

THIS INDENTURE, made this ____ day of _____, 2019, by Eighth Street Investments, LLC, a Wisconsin limited liability company, "**GRANTOR**", and the City of Sheboygan, a municipal corporation of the State of Wisconsin, "**GRANTEE**";

Name and Return Address
City of Sheboygan
City Attorney's Office
828 Center Ave, Suite 210
Sheboygan, WI 53081

Part of 59281108041
Parcel Identification Number (PIN)

WITNESSETH:

KNOW ALL MEN BY THESE PRESENTS, that the said **GRANTOR**, in consideration of the sum of one (\$1.00) dollar and other valuable consideration in hand paid by said **GRANTEE**, receipt whereof is hereby confessed and acknowledged, and the covenants hereinafter contained agree as follows:

1. **GRANTOR** does hereby give and grant to said **GRANTEE**, its successors and assigns, a permanent non-exclusive easement to construct, operate, use, maintain, and repair a storm sewer in, under, and along the following described property, to-wit:

A part of Lots 9 and 10 in Block 151 of the Original Plat of the City of Sheboygan located in the Northeast ¼ of the Southwest ¼ of Section 23, Town 15 North, Range 23 East, City of Sheboygan, Sheboygan County, Wisconsin, and being more particularly described as follows:

Commencing at the Southwest corner of said Lot 10, thence North 00°10'20" East along the West line of said Lot 10, a distance of 71.62 feet to the Point of Beginning for this description; thence North 83°26'34" West a distance of 5.04 feet; thence North 00°10'20" East a distance of 10.06 feet; thence South 83°26'34" East a distance of 5.04 feet to the West line of said Lot 10; thence continuing South 83°26'34" East a distance of 29.01 feet; thence South 06°33'26" West a distance of 10.00 feet; thence North 83°26'34" West a distance of 27.89 feet to the West line of said Lot 10 and the Point of Beginning. Containing 0.00769 acres (335 square feet) of land.

Physical Site Address:

604 N 8th Street
Sheboygan, WI 53081

2. Said storm sewer facilities shall be maintained and kept in good order and condition by **GRANTEE**.
3. That in, and during, whatever construction, reconstruction, or repair work it is, or becomes, necessary in constructing and/or maintaining said facilities, so much of the surface or subsurface of the property as may be disturbed will, at the expense of **GRANTEE**, be replaced in substantially the same condition as it was prior to such disturbances. **GRANTEE** shall save harmless **GRANTOR** from any loss, damage, injury or liability resulting from negligence on the part of **GRANTEE** in connection with said work involved in constructing and/or maintaining of said facilities provided that if loss, damage, injury, or liability results from joint negligence of the parties hereto, then the liability therefore, shall be borne by them in proportion to their respective degree of negligence; provided further, however, that these provisions are subject to the legal defenses which under law **GRANTEE** is entitled to raise.
4. **GRANTOR** agrees not to construct, install, and/or erect structures, buildings, fences, pools, landscaping, etc. that would impede, restrict, prohibit, and/or limit ingress and egress over, across, through, and upon said easement.
5. That in connection with the construction by **GRANTOR** of any structure or building abutting said permanent easement defined limits, **GRANTOR** will assume all liability for any damage to the facilities in the above described easement. **GRANTOR** will indemnify and hold **GRANTEE** harmless from any claims for personal injuries or property damage caused by any negligence of **GRANTOR** arising out of the construction by **GRANTOR** of any structure or building abutting the said permanent utility easement defined limits.
6. Both parties mutually agree that this easement and covenants herein shall run with the land.

IN WITNESS THEREOF, the **GRANTOR**, has caused this instrument to be signed and sealed this _____ day of _____, 2019.

EIGHTH STREET INVESTMENTS, LLC

Paul Weaver
Member

STATE OF WISCONSIN)
) SS
COUNTY OF SHEBOYGAN)

Personally came before me this _____ day of _____, 2019, the above named Paul Weaver to me known to be the persons who executed the foregoing instrument and acknowledged the same.

Notary Public

My Commission expires _____

Accepted By: **CITY OF SHEBOYGAN**

Michael Vandersteen
City of Sheboygan - Mayor

Meredith DeBruin
City of Sheboygan – City Clerk

STATE OF WISCONSIN)
) SS
COUNTY OF SHEBOYGAN)

Personally came before me this ____ day of _____, 2019, the above named Michael Vandersteen, Mayor and Meredith DeBruin, City Clerk to me known to be the persons who executed the foregoing instrument and acknowledged the same.

Notary Public
My Commission expires _____

Acceptance is authorized by and in accordance with Resolution Number _____

This Instrument Drafted By:
Michael P. Born, PLS
Assistant City Engineer / Surveyor

VIII

R. C. No. _____ - 19 - 20. By PUBLIC WORKS COMMITTEE. November 18, 2019.

Your Committee to whom was referred Res. No. 106-19-20 by Alderpersons Wolf and Sorenson authorizing entering into an Agreement with Making Spirits Bright, Inc. for use of Evergreen Park and the Quarryview Center for the annual Making Spirits Bright drive-through holiday lights display; recommends adopting the Resolution with amended agreement.

reg

_____ Committee

I HEREBY CERTIFY that the foregoing Committee Report was duly accepted and adopted by the Common Council of the City of Sheboygan, Wisconsin, on the _____ day of _____, 20____.

Dated _____ 20____. _____, City Clerk

Approved _____ 20____. _____, Mayor

III

4.2

Res. No. 106 19 - 20. By Alderpersons Wolf and Sorenson.
November 4, 2019.

A RESOLUTION authorizing entering into an Agreement with Making Spirits Bright, Inc. for use of Evergreen Park and the Quarryview Center for the annual Making Spirits Bright drive-through holiday lights display.

RESOLVED: That the appropriate City officials are hereby authorized to enter into an Agreement with Making Spirits Bright, Inc. for use of Evergreen Park and the Quarryview Center for the annual Making Spirits Bright drive-through holiday lights display, a copy of which is attached hereto.

*Public Works
adopt with
amended
agreements*





I HEREBY CERTIFY that the foregoing Resolution was duly passed by the Common Council of the City of Sheboygan, Wisconsin, on the _____ day of _____, 20____.

Dated _____ 20____. _____, City Clerk
Approved _____ 20____. _____, Mayor

**AGREEMENT
BETWEEN
CITY OF SHEBOYGAN
AND
MAKING SPIRITS BRIGHT, INC.
FOR USE OF EVERGREEN PARK
AND THE QUARRYVIEW CENTER**

THIS AGREEMENT, hereinafter referred to as the "Agreement," is entered into this _____ day of _____, 2019 (the "Effective Date"), by and between the City of Sheboygan, a municipal corporation existing under the laws of the State of Wisconsin (the "City"), and Making Spirits Bright, Inc., ("MSB") a Wisconsin non-stock corporation with its principal office at 3034 N. 20th Street, Sheboygan, Wisconsin 53081.

RECITALS

(i) For over 100 years, Rotary Clubs have recognized the needs of families in Sheboygan County and have been contributors to, and supporters of, organizations who address those concerns. The motto of Service Above Self is exemplified annually by the projects that the Rotarians support and the grants provided to individuals and organizations as a result of successful fundraisers.

(ii) The Sheboygan County Rotary Clubs have combined their efforts in developing and providing the Making Spirits Bright annual drive-through holiday lights display in Evergreen Park and the Quarryview Center during the holiday season.

(iii) The Sheboygan County Rotary Clubs are partnering with the Sheboygan County Food Bank by asking all who attend this family fun event to bring food pantry items as their admission to the park.

(iv) The Sheboygan County Rotary Clubs have established MSB as a non-stock not for profit corporation for the purposes of developing, promoting, organizing, planning and staging the annual event.

(v) The Sheboygan County Rotary Clubs, through MSB, are again requesting permission to utilize Evergreen Park and the Quarryview Center for the holiday light display event and asking that the parks be closed to vehicular traffic (other than light display patrons) to ensure safety for the event.

(vi) The City is willing to grant such permission subject to certain terms and conditions.

(vii) The parties recognize and understand that Evergreen Park is also utilized in the wintertime for cross country skiing, and that a system of ski trails has been established for outdoor winter recreation by the public.

(viii) This Agreement is intended to authorize MSB to successfully set up, operate and take down their holiday light display while minimizing to the extent possible, impact upon cross country skiing in the park and the grooming of the ski trail system.

NOW, THEREFORE, in consideration of the recitals and mutual agreements herein set forth, and other good and valuable consideration, the receipt and sufficiency of which are hereby acknowledged, the Parties hereto agree as follows:

1. The Parties recognize that in April 2015, the Parties entered into an Agreement for the Use of Evergreen Park and Quarryview Center ("2015 Agreement"). The 2015 Agreement was set for an initial term commencing in mid-October 2015 and ending January 10, 2016. The 2015 Agreement automatically renewed for successive one-year terms through January 10, 2020. The Parties wish to conduct the 2019-2020 administration of the holiday light display event under this Agreement rather than the April 2015 Agreement.

2. The City agrees to make Evergreen Park available to MSB for its drive-through holiday light display between the Effective Date of this Agreement and January 16, 2020¹ and the Quarryview Center available to MSB between the Effective Date of this Agreement and December 31, 2019, subject to the following:

(a) MSB has, prior to the effective date of this Agreement, remitted \$1,500 to the City for the use of Evergreen Park and the Quarryview Center for the 2019-2020 administration of the holiday light display event. For the avoidance of doubt, for all future administrations of the holiday light display covered by this Agreement, MSB shall remit payment of \$1,500 per year for the use of Evergreen Park and the Quarryview Center

¹ This time period shall include the setup and removal of all lights and other elements included in the holiday light display.

on or before the March 1 preceding the event commencing in that calendar year.

- (b) MSB shall complete all event forms reasonably requested by the City's Department of Public Works, pursuant to the deadlines set forth.
- (c) MSB shall indemnify, defend, and hold harmless the City from all claims, actions and suits brought against the City on account of any injuries or damages received or sustained by any party or parties by or from the MSB, its employees, agents, or volunteers, arising from the exercise of the rights and privileges granted herein or on account of any act or omission of the MSB or its employees, agents, or volunteers.
- (d) MSB agrees to provide the City with a certificate of insurance illustrating the existence of a commercial general liability insurance policy providing at least \$2,000,000 in coverage, naming the City as an additional insured.
- (e) MSB agrees to reimburse the City for damages to the park and the Quarryview Center caused by or arising as a result of the use of said parks and park facilities under this Agreement.
- (f) MSB agrees to strictly abide by all rules established by the Department of Public Works for its use of the parks.
- (g) MSB shall work with the City Parks Department to provide room for groomed trails as shown on the map attached to this Agreement as Exhibit A throughout its use of Evergreen Park.
- (h) MSB shall leave the area identified as Practice Ski Area on Exhibit B available for use by cross country skiers at all times during its occupancy of Evergreen Park.
- (i) MSB shall make best efforts to allow for a 10 foot wide ski trail around the south side of the Area #4 parking lot beginning on January 3 of each year.

- (j) MSB shall have all ski trail areas in Evergreen Park available for grooming by January 17 of each year.
- (k) In recognition of the City's support of MSB, MSB shall recognize the City of Sheboygan as an in-kind donor in any written materials distributed at Making Spirits Bright, including a City logo on the map of Evergreen Park included in the written materials and any other recognition provided to other in-kind donors to MSB.

3. As set forth above, this Agreement shall be for an initial term commencing the Effective Date of this Agreement and ending January 13, 2020 at 5:00 p.m. It shall automatically renew to allow use of Evergreen Park and Quarryview Center on the following schedule, unless notice is provided by either party to the other no later than May 31 of each year:

Evergreen Park

October 5, 2020 through January 11, 2021 at 5:00 p.m.
 October 4, 2021 through January 10, 2022 at 5:00 p.m.
 October 3, 2022 through January 16, 2023 at 5:00 p.m.
 October 1, 2023 through January 15, 2024 at 5:00 p.m.
 October 7, 2024 through January 13, 2025 at 5:00 p.m.

Quarryview Center

November 5, 2020 through December 31, 2020
 November 4, 2021 through December 31, 2021
 November 3, 2022 through December 31, 2022
 November 2, 2023 through December 31, 2023
 November 7, 2024 through December 31, 2024
 November 6, 2025 through December 31, 2025

In no event shall this Agreement be automatically renewed beyond January 13, 2025. The Director of Public Works may, subject to the availability of Evergreen Park, allow MSB to start on an earlier date than that specified in this Section.

4. Termination.

In the event that MSB breaches its obligations under this Agreement, the Director of Public Works may provide a Notice of Intent to Terminate to:

Kenneth R. King
730 S. 8th Street, Unit 506
Sheboygan, WI 53082

Such Notice of Intent to Terminate shall become effective upon ratification by the Common Council of the City.

IN WITNESS WHEREOF, the Parties have duly executed this Agreement as of the date first above written.

MAKING SPIRITS BRIGHT, INC.

CITY OF SHEBOYGAN

By: _____

By: _____
Michael J. Vandersteen
Mayor

Date: _____

Date: _____

ATTEST:

Meredith DeBruin
City Clerk

Date: _____

EXHIBIT A

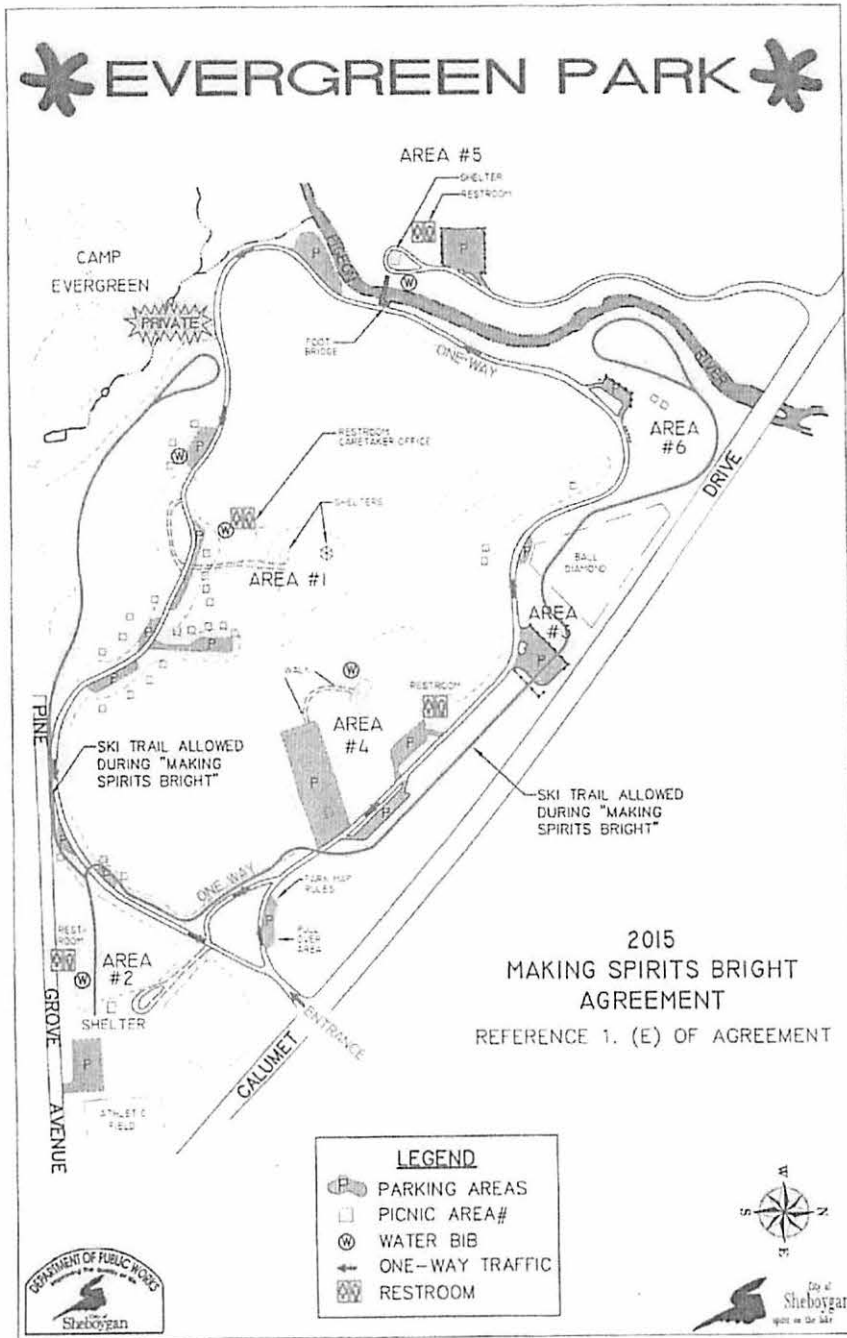



EXHIBIT B

VIII

R. C. No. _____ - 19 - 20. By PUBLIC WORKS COMMITTEE. November 18, 2019.

Your Committee to whom was referred Res. No. 109-19-20 by Alderpersons Bohren and Mitchell demanding Union Pacific Railroad repair three at-grade railroad crossings in the City of Sheboygan in accordance with Wis. Stat. § 86.12; recommends adopting the Resolution.

recy

_____	_____
_____	_____
_____	_____

Committee

I HEREBY CERTIFY that the foregoing Committee Report was duly accepted and adopted by the Common Council of the City of Sheboygan, Wisconsin, on the _____ day of _____, 20____.

Dated _____ 20____. _____, City Clerk

Approved _____ 20____. _____, Mayor

117

... ..
... ..
... ..

... ..
... ..
... ..

... ..
... ..
... ..

... ..
... ..
... ..

... ..
... ..
... ..

... ..
... ..
... ..

III

4.4

Res. No. 109-19-20. By Alderpersons Bohren and Mitchell.
November 4, 2019.

A RESOLUTION demanding Union Pacific Railroad repair three at-grade railroad crossings in the City of Sheboygan in accordance with Wis. Stat. § 86.12.

WHEREAS, Union Pacific Railroad operates rail lines throughout the City of Sheboygan; and

WHEREAS, Wis. Stat. § 86.12 requires railroads to maintain public at-grade crossings in good condition and repair for public travel; and

WHEREAS, three at-grade rail crossings have not been maintained as required by Wis. Stat. § 86.12: (1) the at-grade rail crossing at 4200 South Taylor Drive (Crossing Number 199843G); (2) the at-grade rail crossing at the intersection of South 12th Street and Greenfield Ave. (Crossing Number 180214L); and (3) the at-grade rail crossing at 1700 New Jersey Ave. (Crossing Number 180296V) (collectively the "Unrepaired At-Grade Crossings"); and

WHEREAS, City Staff estimate that they have received more than fifty complaints about the Unrepaired At-Grade Crossings; and

WHEREAS, specifically, at Crossing Number 199843G the rubber crossing sections have become loose and have shifted, and the abutting asphalt has settled creating a hazard for vehicle, bicycle, and pedestrian traffic; and

WHEREAS, at Crossing Number 180214L the rubber crossing sections have become loose and have shifted, and the abutting asphalt has settled creating a hazard for vehicle, bicycle, and pedestrian traffic; and

WHEREAS, at Crossing Number 180296V the asphalt crossing has deteriorated creating a hazard for vehicle, bicycle, and pedestrian traffic; and

WHEREAS, pictures of the condition of the Unrepaired At-Grade Crossings as of October 23, 2019 are attached to this Resolution; and

WHEREAS, the condition of the Unrepaired At-Grade Crossings has not meaningfully improved since the pictures were taken on October 23, 2019; and

WHEREAS, the Unrepaired At-Grade Crossings have not been maintained in good condition and repair for public travel; and

WHEREAS, City Staff has attempted to work with Union Pacific Railroad since at least March 2017 with respect to these at-grade crossings, with no improvements to the Unrepaired At-Grade Crossings; and

WHEREAS, the City of Sheboygan demands that Union Pacific Railroad pave, plank, repair, change, or otherwise improve the Unrepaired At-Grade Crossings so that each complies with the requirements of Wis. Stat. § 86.12.

Public works adopt.

NOW, THEREFORE, BE IT RESOLVED: That the Common Council of the City of Sheboygan hereby directs City Staff to serve a copy of this resolution upon Union Pacific Railroad requiring the repair of the Unrepaired At-Grade Crossings.

BE IT FURTHER RESOLVED: That in the event Union Pacific Railroad fails to repair the Unrepaired At-Grade Crossings within thirty (30) days after service of this Resolution upon Union Pacific Railroad's registered agent as designated by Wis. Stat. § 190.03, the Common Council of the City of Sheboygan hereby directs City Staff to take all necessary steps to petition the Office of the Commissioner of Railroads for an investigation and order for the repair of the Unrepaired At-Grade Crossings in the City of Sheboygan, Sheboygan County, Wisconsin.

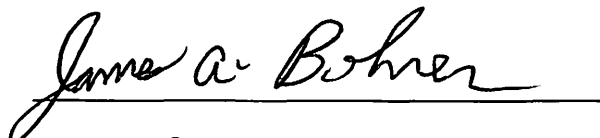

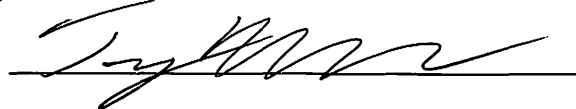

I HEREBY CERTIFY that the foregoing Resolution was duly passed by the Common Council of the City of Sheboygan, Wisconsin, on the _____ day of _____, 20____.

Dated _____ 20____. _____, City Clerk

Approved _____ 20____. _____, Mayor

REPORT PROBLEM
OR EMERGENCY
1-800-848-8715
X-ING 180214L
UNION PACIFIC RAILROAD

10.23.2019 10:47









10.23.2019 10:48



10.23.2019 10:48









10.23.2019 12:55



10.23.2019 12:56

REPORT PROBLEM
OR EMERGENCY
1-800-848-8715
X-ING 180296V
UNION PACIFIC RAILROAD

10.23.2019 13:35



10.23.2019 13:35





10.23.2019 13:36

REPORT PROBLEM
OR EMERGENCY
1-800-848-8715
X-ING 199843G
UNION PACIFIC RAILROAD

10.23.2019 10:29





10.23.2019 10:29







10.23.2019 10:30





10.23.2019 10:31

10.23.2019 10:31





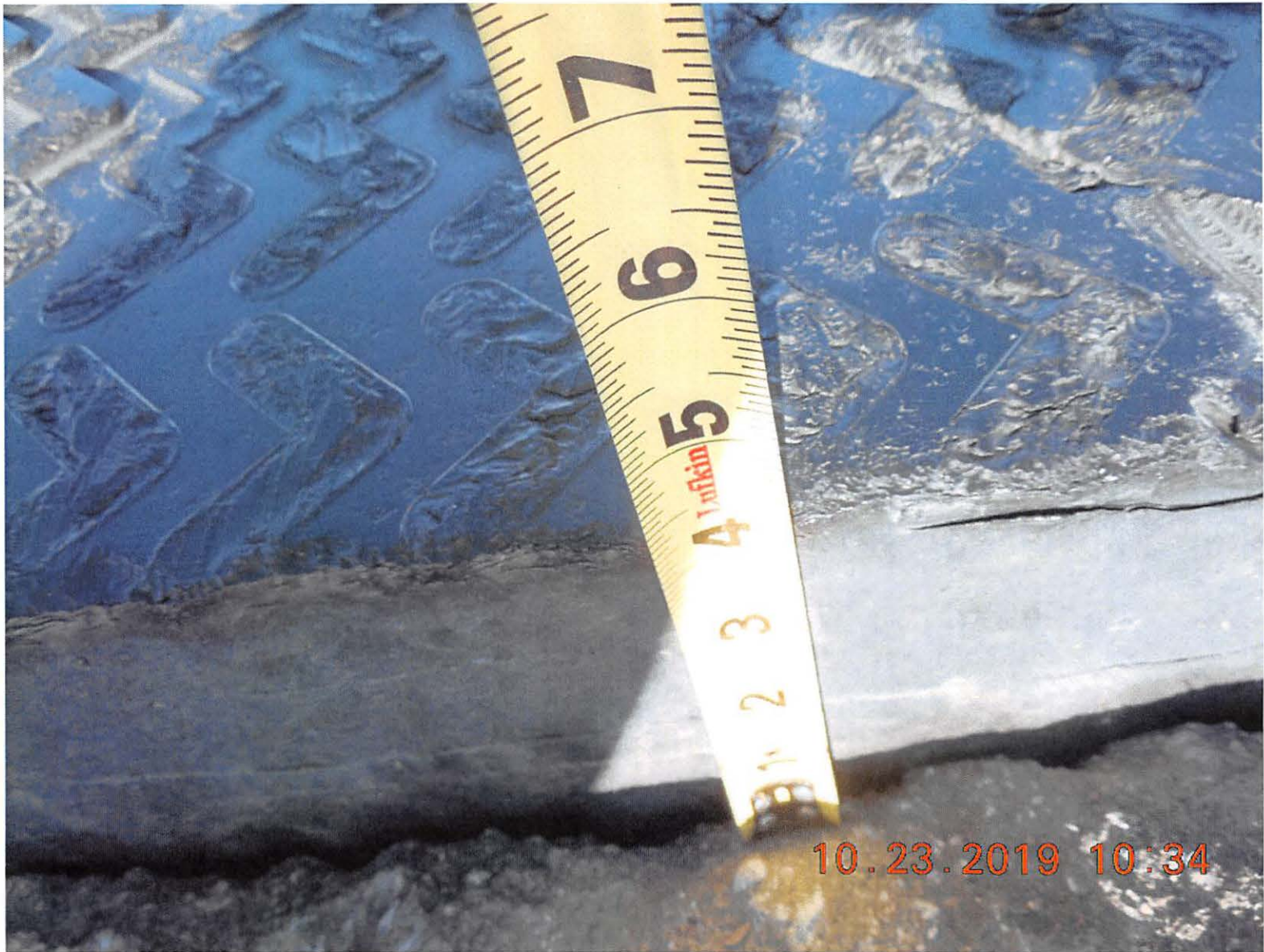



VIII

R. C. No. _____ - 19 - 20. By PUBLIC WORKS COMMITTEE. November 18, 2019.

Your Committee to whom was referred DIRECT REFERRAL Res. No. 111-19-20 by Alderpersons Wolf and Sorenson authorizing an emergency repair of the sidewalk along the shoreline of Lake Michigan at South Pier; recommends adopting the Resolution.

neg

_____	_____
_____	_____
_____	_____

Committee

I HEREBY CERTIFY that the foregoing Committee Report was duly accepted and adopted by the Common Council of the City of Sheboygan, Wisconsin, on the _____ day of _____, 20____.

Dated _____ 20____. _____, City Clerk

Approved _____ 20____. _____, Mayor

III

DIRECT REFERRAL TO PUBLIC WORKS COMMITTEE

Res. No. 111 - 19 - 20. By Alderpersons Wolf and Sorenson.
November 12, 2019.

A RESOLUTION authorizing an emergency repair of the sidewalk along the shoreline of Lake Michigan at South Pier.

WHEREAS, the slope adjacent to and the subgrade underneath the existing sidewalk along the shoreline of Lake Michigan at South Pier has eroded; and

WHEREAS, immediate action is necessary to repair the slope and subgrade before further risk to the health and welfare of the city and its residents can occur; and

WHEREAS, while the necessary work to address the erosion of the sidewalk subgrade constitutes public construction, as used in Wis. Stat. § 62.15(1), which would ordinarily require taking and receiving bids, because the erosion has created an emergency which endangers the public health or welfare of the city, Wis. Stat. § 62.15(1b) provides that public bidding is not necessary in order to promptly address the emergency.

NOW, THEREFORE, BE IT RESOLVED: That the appropriate City officials are hereby authorized to enter into a contract with A. Chappa Construction, LLC, in substantially similar form to that attached, for repair of the slope and sidewalk subgrade as a result of the erosion.

BE IT FURTHER RESOLVED: That the appropriate City officials are hereby authorized to draw funds from the Capital Project Fund - Sidewalk/Trail Improvements (Account No. 40033140-631300) in the total amount of \$138,000 pursuant to the contract.

Public
works
adopt.

BE IT FURTHER RESOLVED: That for the avoidance of doubt, to the extent necessary, the appropriate City officials are authorized to use Capital Project Fund balance for this project.

I HEREBY CERTIFY that the foregoing Resolution was duly passed by the Common Council of the City of Sheboygan, Wisconsin, on the _____ day of _____, 20____.

Dated _____ 20____. _____, City Clerk

Approved _____ 20____. _____, Mayor

**AGREEMENT
BETWEEN THE CITY OF SHEBOYGAN, WISCONSIN AND
A. CHAPPA CONSTRUCTION, LLC**

**REGARDING EMERGENCY REPAIRS TO THE SOUTH PIER SIDEWALK ALONG
THE SHORELINE OF LAKE MICHIGAN**

This Agreement (“Agreement”) is made and entered into effective this ____ day of _____, 2019 (the “Effective Date”), by and between the City of Sheboygan (the “City”), a municipal corporation, and A. Chappa Construction, LLC (“Contractor”).

WITNESSETH:

WHEREAS, the slope adjacent to and the subgrade underneath the existing sidewalk at South Pier along the shoreline of Lake Michigan has eroded, which requires immediate action to repair the slope and subgrade before further risk to the health and welfare of the city and its residents can occur; and

WHEREAS, Contractor is willing and able to complete the necessary repairs under the terms set forth in this Agreement.

NOW, THEREFORE, in consideration of the mutual covenants herein contained, the parties hereto agree as follows:

Article 1. Scope of Services

Contractor shall provide all labor and materials—on a time and materials basis—to repair the slope adjacent to and the subgrade underneath the 600 foot section of the South Pier sidewalk that is depicted in the attached Exhibit A. In general, this process will involve placing plywood at the edge of the stone to control concrete slump, pouring and properly placing a concrete slurry mix under the sidewalk, and installing rip rap stone (the “Services”).

For the avoidance of doubt, the Services includes:

- Mobilization, supervision, and a storage trailer
- ¾” plywood ground protection for access
- Plywood forming and reinforced poly at stone edge to control concrete slump
- Installation of 4” to 6” rip rap stone to fill larger voids
- Pour and vibrate two-bag concrete slurry mix throughout the area to be repaired, and vibrate to fill voids
- Install 6” to 12” rip rap stone on top of concrete slurry

Contractor shall be responsible for obtaining any and all applicable City permits and paying any and all applicable permit fees prior to beginning work.

Contractor shall be responsible for furnishing, erecting, and maintaining suitable barricades, warning signs, flashers, fencing, and other protective equipment to properly protect and safeguard its personnel and the public during all phases of the Services.

Contractor shall give notice to the proper authorities in charge of streets, gas and water pipes, electric and other conduits, railroad, poles, catch basins, sewers, and all other property that may be affected by Contractor's operations, at least three (3) business days before beginning operations. Contractor shall not hinder or interfere with any persons in the protection of such property or with the operations of utilities at any time. Contractor shall protect such utilities from damage and unnecessary exposure. The cost of repairing any damage to utilities shall be the responsibility of Contractor.

Article 2. Standard of Care

Contractor shall be responsible for completion of the Services in a manner consistent with that degree of care and skill ordinarily exercised by members of the same profession currently practicing under similar circumstances ("Standard of Care"). The City shall be the sole judge of the adequacy of Contractor's work in meeting the Standard of Care; however, the City shall not unreasonably withhold its approval as to the adequacy of Contractor's performance. Upon notice to Contractor, Contractor will, without additional compensation, correct or replace any and all Services not meeting the Standard of Care.

Article 3. Responsibilities of the City

The City designates Ryan Sazama as its designated project manager for purposes of this Agreement.

Article 4. Compensation

The City shall pay Contractor an amount not to exceed One Hundred Thirty Eight Thousand Dollars (\$138,000) for Contractor to complete the Services set forth in Article 1. As noted in Article 1, this will be done on a time and materials basis:

- The labor rate for this work shall be Seventy Two Dollars per Hour (\$72.00) plus 7% for overhead and profit.
- Materials shall be charged at Contractor's actual cost.

Invoices may be sent via first class mail postage prepaid or via email. Payment will be remitted to Contractor within forty-five days of receipt of invoice. Contractor shall submit an invoice to the City at the completion of the services set forth in Article 1. The invoice shall be sent to:

Ryan Sazama
Department of Public Works
City of Sheboygan
2026 New Jersey Ave.
Sheboygan, Wisconsin 53081
ryan.sazama@sheboyganwi.gov

Additional services not set forth in Article 1, or changes in the Services must be authorized in writing by the City or its designated project manager prior to such work being performed, or expenses incurred. The City shall not make payment for any unauthorized work or expenses.

The City may withhold payment, in whole or in part, to the extent necessary to protect itself from a loss on account of any of the following:

- Defective work.
- Evidence indicating the probable filing of claims by other parties against Contractor which may adversely affect the City.
- Failure of Contractor to make payments due to subcontractors, material suppliers, or employees.
- Damage to the City or a third party.

The submission of any request for payment shall be deemed a waiver and release by Contractor of all liens and claims with respect to the work and period to which such payment request pertains except as specifically reserved and noted on such request.

Article 5. Appropriation of Funds

Notwithstanding any other provision of this Agreement, if funds for the continued fulfillment of this Agreement by the City are at any time not forthcoming or are insufficient, through failure of any entity, including the City itself, to appropriate funds or otherwise, then the City shall have the right to terminate this Agreement without penalty.

Article 6. Performance and Payment Bond

Contractor shall, within ten (10) days of the approval of this Agreement by the Common Council of the City of Sheboygan, provide the City with a Performance Bond and a Payment Bond in the amount of one hundred percent (100%) of the contract amount.

Failure by Contractor to perform the work in a timely or satisfactory fashion may result in forfeiture of Contractor's Performance Bond.

If the Surety on any bond furnished by Contractor becomes a party to supervision or liquidation, or its right to do business in the State of Wisconsin is terminated, Contractor shall, within thirty (30) calendar days thereafter, substitute another bond or surety, both of which must be acceptable to the City.

Article 7. Schedule

Contractor shall begin the Services as soon as is practicable after this Agreement is approved by the Common Council of the City of Sheboygan and shall continue the prosecution of the Services as quickly as is practicable until the Services are completed. Contractor shall complete the services by December 15, 2019 or within such extra time as may have been allowed by a mutually agreed extension.

The Parties agree that no charges or claims for damages shall be made by Contractor for any delays or hindrances, from any cause whatsoever, during the progress of any portion of the services specified in the Agreement. Such delays or hindrances, if any, may be compensated for by an extension of time for a reasonable period as may be mutually agreed upon between the Parties, it being understood however, that permitting Contractor to proceed to complete any service, or any part of the services / project, after the date to which the time of completion may have been extended shall, in no way operate as a waiver on the part of the City of any of its rights herein.

Article 8. Quality of Materials

All materials used by Contractor shall be new, newest model year, and free from defects. Items which are used, demonstrators, obsolete, seconds, of which have been discontinued are unacceptable without prior written approval by the City.

Article 9. Safety Requirements

Contractor shall be responsible for the safety of employees at all times and shall provide all equipment necessary to insure their safety. Contractor shall ensure the enforcement of all applicable safety rules, regulations, ordinances and laws, whether federal, state, or local. Contractor's Superintendent of Safety shall make daily inspections upon the arrival and leaving of the site at the close of each workday.

Article 10. Open Records

Both parties understand that the City is bound by the Wisconsin Public Records Law and, as such, this contract is subject to that law. Contractor acknowledges that it is obligated to assist the City in retaining and producing records that are subject to Wisconsin Public Records Law, and that the failure to do so shall constitute a material breach of the contract, and that Contractor must defend and hold the City harmless from liability under that law. Except as otherwise authorized, those records shall be maintained for a period of seven (7) years after receipt of final payment under the Agreement.

Article 11. Termination

The City may terminate or suspend performance of this Agreement at the City's prerogative at any time upon written notice to Contractor. Contractor shall terminate or suspend performance of the Services on a schedule acceptable to the City and the City shall pay Contractor for all the Services performed up to the date that written notice is received, plus reasonable termination or suspension expenses. Upon restart, an equitable adjustment shall be made to Contractor's compensation and the schedule of services.

If Contractor defaults or fails to fulfill in a timely and proper manner its obligations pursuant to this Agreement, the City may, seven (7) days after written notice has been delivered to Contractor, and without prejudice to any other remedy it may have, make good such deficiencies and may deduct the cost thereof from the payment then or thereafter due to Contractor. In the alternative the City may, at its option, terminate this Agreement and take possession of the site and of all materials, equipment, tools, and construction equipment and machinery thereon owned by Contractor, and may finish the project by whatever method it may deem expedient. In case the expenses incurred by the City (including payments previously made to Contractor) shall be less than the sum which

would have been payable under the Agreement if it had been completed by Contractor, Contractor shall be entitled to receive the difference. However, in case such expense shall exceed the sum which would have been payable under the Agreement, Contractor will be liable and shall pay to the City the amount of said excess. By taking over prosecution of the work, the City does not forfeit the right to recover damages from Contractor or its surety for failure to complete the work in the time specified.

Article 12. Default

If Contractor breaches this Agreement or fails to perform the work in an acceptable manner, it shall be considered in default. Any one or more of the following will be considered a default:

- Failure to begin the work under this Agreement within the time specified.
- Failure to perform the work with sufficient supervision, workers, equipment and materials to insure prompt completion of said work within the time limits allowed.
- Unsuitable performance of the work as determined by City.
- Neglecting or refusing to remove defective materials or failure to perform anew such work as shall have been rejected.
- Discontinuing the prosecution of the work or any part of it.
- Inability to finance the work adequately.
- If, for any other reason, Contractor breaches this Agreement or fails to carry on the work in an acceptable manner.

The City shall send Contractor a written notice of default. If Contractor, within a period of seven (7) days after such notice, fails to remedy the default, then the City shall have full power and authority, without violation of the Agreement, to take the prosecution of the work out of the hands of Contractor, as set forth in this Agreement.

Article 13. Identity of Contractor

Contractor acknowledges that one of the primary reasons for its selection by the City to perform the Services is the qualifications and experience of Contractor. Contractor thus agrees that the Services to be performed pursuant to this Agreement shall be performed by Contractor. Contractor shall not subcontract any part of the Services without the prior written permission of the City. The City's project manager shall have the ability to provide this written permission. The City reserves the right to reject any of the Contractor's personnel or proposed outside professional sub-consultants, and the City reserves the right to request that acceptable replacement personnel be assigned to the project.

Article 14. Independent Contractor Status

During the entire term of this Agreement, Contractor shall be an independent contractor, and in no event shall any of its personnel, agents or sub-contractors be construed to be, or represent themselves to be, employees of the City. Contractor shall be solely responsible for the payment and reporting of all employee and employer taxes, including social security, unemployment, and any other federal, state, or local taxes required to be withheld from employees or payable on behalf of its employees.

Article 15. Indemnification

Contractor shall indemnify, defend, and hold the City—including its Officials, Agents, and Employees—free and harmless from all liability, including, but not limited to, losses, damages, costs, attorney’s fees, expenses, causes of action, claims, or judgments resulting from claimed injury, death, damage to property, or loss of use of property or any person or legal entity arising out of or in any way connected with the performance of work or work to be performed under this Agreement.

Contractor shall reimburse the City for any costs, expenses, judgments, and attorney’s fees paid or incurred, by or on behalf of the City, its Officials, Agents, or Employees, or paid for on behalf of the City, its Officials, Agents, or Employees by insurance purchased or self-insurance provided by the City arising out of or in any way connected with the performance of work or work to be performed under this Agreement.

Contractor shall further indemnify, defend, and hold harmless the City, its Officials, Agents, and Employees from liability or claims for any injuries to or death of Contractor’s employees (or the employees of any authorized subcontractor) arising out of or in any way connected with the work or work to be performed under this Agreement, including protection against any claim of the contractor or subcontractor for any payments under any worker’s compensation law or any expenses of or any payments made by any worker’s compensation insurance carrier on behalf of said contractor or sub-contractor and the contractor shall indemnify the City for any costs, expenses, judgments, and attorney’s fees with respect to any above referenced workers’ compensation claims incurred or paid by the City or paid on its behalf or on behalf of its Officials, Agents, or Employees by insurance purchased or self-insurance provided by the City of Sheboygan.

Article 16. Insurance

Contractor shall not commence work under this Agreement until it has obtained all insurance required under this Article. Additionally, Contractor shall not allow any approved subcontractor to commence work on its subcontract until the subcontractor has obtained all insurance required under this Article.

During the performance of any and all Services under this Agreement, Contractor shall maintain the following insurance in full force and effect, and shall provide proof of insurance to the Purchasing Agent listing the City of Sheboygan as an additional insured:

- a. **Workers’ Compensation Insurance** — Contractor shall acquire and maintain, for the duration of the Agreement, Workers’ Compensation Insurance that meets all statutory requirements. In the event this Agreement authorizes any work to be sublet, Contractor shall require any subcontractor to similarly provide Workers’ Compensation Insurance in accordance with all statutory requirements.
- b. **Commercial General Liability Insurance** — Contractor shall acquire and maintain, for the duration of the Agreement, Commercial General Liability Insurance with a policy limit of at least \$1,000,000 per occurrence and \$2,000,000 in the aggregate.

All insurance must be primary and non-contributory to any insurance or self-insurance carried by the City.

Approval of the insurance by the City shall not relieve or decrease the extent to which Contractor may be held responsible for payment of damages resulting from Contractor's provision of the Services or its operations under this Agreement. If Contractor fails or refuses to procure or maintain the insurance required by these provisions, or fails or refuses to furnish the City the required proof that the insurance has been procured and is in force and paid for, the City shall have the right at its election to terminate the Agreement.

Article 17. Conflict of Interest

Contractor declares that it has no present interest, nor shall it acquire any interest, direct or indirect, which would conflict with the performance of Services under this Agreement. Contractor agrees that no person having any such interest shall be employed in the performance of this Agreement.

Article 18. Waiver

No failure of either party to enforce a term of this Agreement against the other shall be construed as a waiver of that term, nor shall it in any way affect the party's right to enforce that term. No waiver by any party of any term of this Agreement shall be considered to be a waiver of any other term or breach thereof.

Article 19. Severability

The invalidity, illegality or unenforceability of any provision of this Agreement or the occurrence of any event rendering any portion or provision of this Agreement void shall in no way affect the validity or enforceability of any other portion or provision of this Agreement. Any void provision shall be deemed severed from this Agreement, and the balance of the Agreement shall be construed and enforced as if it did not contain the particular provision to be held void. The parties further agree to amend this Agreement to replace any stricken provision with a valid provision that comes as close as possible to the intent of the stricken provision. The provisions of this Article shall not prevent this entire Agreement from being void should a provision which is of the essence of this Agreement be determined void.

Article 20. Assignment

Neither the City nor Contractor shall assign any rights or duties under this Agreement without the prior written consent of the other party.

Article 21. Third Party Rights

Nothing in this Agreement shall be construed to give any rights or benefits to anyone other than the City and Contractor.

Article 22. Governing Law and Venue

This Agreement shall be governed by the laws of the State of Wisconsin. Venue of any disputes arising under this Agreement shall be in the Sheboygan County Circuit Court, Wisconsin.

Article 23. Non-Discrimination

In connection with the performance of work under this Agreement, Contractor agrees not to discriminate against any employee or applicant for employment because of age, race, religion, color, handicap, sex, physical condition, developmental disability (as defined in Wis. Stat. 51.01(5)), sexual orientation (as defined in Wis. Stat. 111.32(13m)), or national origin. This provision shall include, but not be limited to, the following: employment, upgrading, demotion or transfer, recruitment or recruitment advertising, layoff or termination, rates of pay or other forms of compensation, and selection for training, including apprenticeship. Contractor further agrees to take affirmative action to ensure equal employment opportunities.

Article 24. Compliance with Laws

In performing the Services under this Agreement, Contractor shall comply with any and all applicable federal, state and local statutes, ordinances, plans, and regulations.

The City reserves the right to cancel this Agreement if Contractor fails to follow the requirements of Wis. Stat. 77.66 and related statutes regarding certification for collection of sales and use tax. The City also reserves the right to cancel this Agreement with any state or federally debarred contractor.

Contractor shall have any and all licenses and permits required to perform the work specified, and shall furnish proof of such licensing authorization and permits upon request.

Article 25. Notices

Any notice required by this Agreement shall be made in writing to the individuals/addresses specified below:

City:

Contractor:

City Clerk	Andy Chappa
City of Sheboygan	A Chappa Construction, LLC
828 Center Ave.	443 North Main Street
Sheboygan, Wisconsin 53083	Sheboygan Falls, Wisconsin 53085

Nothing contained in this Article shall be construed to restrict the transmission of routine communications between representatives of the City and Contractor.

Article 26. Intent to be Bound

The City and Contractor each binds itself and its successors, executors, administrators, permitted assigns, legal representatives and, in the case of a partnership, its partners to the other party to this Agreement, and to the successors, executors, administrators, permitted assigns, legal representatives and partners of such other party in respect to all provisions of this Agreement.

Article 27. Force Majeure

Neither party shall be in default by reason of any failure in performance of this Agreement in accordance with reasonable control and without fault or negligence on their part. Such causes may include, but are not restricted to, acts of nature or the public enemy, acts of the government in either

its sovereign or contractual capacity, fires, floods, epidemics, quarantine restrictions, strikes, freight embargoes, and unusually severe weather. In every case, the failure to perform must be beyond the reasonable control and without the fault or negligence of the party.

Article 28. Integration and Modification

This Agreement, including all Exhibits incorporated by reference, represents the entire and integrated agreement between the City and the Contractor. It supersedes all prior and contemporaneous communications, representations and agreements, whether oral or written, relating to the subject matter of this Agreement. This Agreement may be modified only by a written amendment signed by both parties hereto.

Article 29. Non-Collusion

Contractor is certifying, under penalty of perjury, that to the best of its knowledge and belief:

- a. The price in its response was arrived at independently, without collusion, consultation, communication, or agreement, for the purpose of restricting competition as to any other matter relating to such prices with any other competitor.
- b. No attempt was made to induce any other person, partnership, or corporation to submit or not submit a response to the City regarding the Services for the purpose of restricting competition.

Article 30. Other Provisions

- a. Material Safety Data Sheet. If any item(s) on an order(s) resulting from this Agreement is a hazardous chemical, as defined under 29 C.F.R. 1910.1200, Contractor shall provide one (1) copy of a Material Safety Data Sheet for each item with the shipped container(s) and one (1) copy with the invoice(s).
- b. Advertising and News Releases. Reference to or use of the City, or any of its departments, officials, or employees, for commercial promotion is prohibited. News releases pertaining to this procurement shall not be made without prior approval of the City. Release of broadcast e-mails pertaining to this procurement shall not be made without prior written authorization of the City.
- c. Foreign Corporation. A foreign corporation (any corporation other than a Wisconsin corporation) which becomes a party to this Agreement is required to conform to all the requirements of Wis. Stat. 180 relating to a foreign corporation, and must possess a certificate of authority from the Wisconsin Department of Financial Institutions, unless the corporation is transacting business in interstate commerce or is otherwise exempt from the requirement of obtaining a certificate of authority.
- d. Neither Party the Drafter. Despite the possibility that one party or its representatives may have prepared the initial draft of this Agreement (or any provision thereof), or played a greater role in the preparation of subsequent drafts, the parties agree that neither of them shall be deemed the drafter of this Agreement.

e. Authority. Each person executing this Agreement on behalf of a party hereto represents and warrants to the other party: That the execution and delivery of this Agreement has been duly authorized, that the person or persons executing this Agreement have the full power, authority, and right to do so, and that such execution is sufficient and legally binding on such party to enable this Agreement to be enforceable in accordance with its terms.

IN WITNESS WHEREOF, the parties hereto have caused this Agreement to be executed the day and year first written above.

CITY OF SHEBOYGAN, WISCONSIN

CONTRACTOR

BY: _____
Michael J. Vandersteen, Mayor

BY: _____

ATTEST: _____
Meredith DeBruin, City Clerk

ATTEST: _____

DATE: _____

DATE: _____

**AGREEMENT
BETWEEN THE CITY OF SHEBOYGAN, WISCONSIN AND
A. CHAPPA CONSTRUCTION, LLC**

**REGARDING EMERGENCY REPAIRS TO THE SOUTH PIER SIDEWALK ALONG
THE SHORELINE OF LAKE MICHIGAN**

This Agreement ("Agreement") is made and entered into effective this ____ day of _____, 2019 (the "Effective Date"), by and between the City of Sheboygan (the "City"), a municipal corporation, and A. Chappa Construction, LLC ("Contractor").

WITNESSETH:

WHEREAS, the slope adjacent to and the subgrade underneath the existing sidewalk at South Pier along the shoreline of Lake Michigan has eroded, which requires immediate action to repair the slope and subgrade before further risk to the health and welfare of the city and its residents can occur; and

WHEREAS, Contractor is willing and able to complete the necessary repairs under the terms set forth in this Agreement.

NOW, THEREFORE, in consideration of the mutual covenants herein contained, the parties hereto agree as follows:

Article 1. Scope of Services

Contractor shall provide all labor and materials—on a time and materials basis—to repair the slope adjacent to and the subgrade underneath the 600 foot section of the South Pier sidewalk that is depicted in the attached Exhibit A. In general, this process will involve placing plywood at the edge of the stone to control concrete slump, pouring and properly placing a concrete slurry mix under the sidewalk, and installing rip rap stone (the "Services").

For the avoidance of doubt, the Services includes:

- Mobilization, supervision, and a storage trailer
- ¾" plywood ground protection for access
- Plywood forming and reinforced poly at stone edge to control concrete slump
- Installation of 4" to 6" rip rap stone to fill larger voids
- Pour and vibrate two-bag concrete slurry mix throughout the area to be repaired, and vibrate to fill voids
- Install 6" to 12" rip rap stone on top of concrete slurry

Contractor shall be responsible for obtaining any and all applicable City permits and paying any and all applicable permit fees prior to beginning work.

Contractor shall be responsible for furnishing, erecting, and maintaining suitable barricades, warning signs, flashers, fencing, and other protective equipment to properly protect and safeguard its personnel and the public during all phases of the Services.

Contractor shall give notice to the proper authorities in charge of streets, gas and water pipes, electric and other conduits, railroad, poles, catch basins, sewers, and all other property that may be affected by Contractor's operations, at least three (3) business days before beginning operations. Contractor shall not hinder or interfere with any persons in the protection of such property or with the operations of utilities at any time. Contractor shall protect such utilities from damage and unnecessary exposure. The cost of repairing any damage to utilities shall be the responsibility of Contractor.

Article 2. Standard of Care

Contractor shall be responsible for completion of the Services in a manner consistent with that degree of care and skill ordinarily exercised by members of the same profession currently practicing under similar circumstances ("Standard of Care"). The City shall be the sole judge of the adequacy of Contractor's work in meeting the Standard of Care; however, the City shall not unreasonably withhold its approval as to the adequacy of Contractor's performance. Upon notice to Contractor, Contractor will, without additional compensation, correct or replace any and all Services not meeting the Standard of Care.

Article 3. Responsibilities of the City

The City designates Ryan Sazama as its designated project manager for purposes of this Agreement.

Article 4. Compensation

The City shall pay Contractor an amount not to exceed One Hundred Thirty Eight Thousand Dollars (\$138,000) for Contractor to complete the Services set forth in Article 1. As noted in Article 1, this will be done on a time and materials basis:

- The labor rate for this work shall be Seventy Two Dollars per Hour (\$72.00) plus 7% for overhead and profit.
- Materials shall be charged at Contractor's actual cost.

Invoices may be sent via first class mail postage prepaid or via email. Payment will be remitted to Contractor within forty-five days of receipt of invoice. Contractor shall submit an invoice to the City at the completion of the services set forth in Article 1. The invoice shall be sent to:

Ryan Sazama
Department of Public Works
City of Sheboygan
2026 New Jersey Ave.
Sheboygan, Wisconsin 53081
ryan.sazama@sheboyganwi.gov

Additional services not set forth in Article 1, or changes in the Services must be authorized in writing by the City or its designated project manager prior to such work being performed, or expenses incurred. The City shall not make payment for any unauthorized work or expenses.

The City may withhold payment, in whole or in part, to the extent necessary to protect itself from a loss on account of any of the following:

- Defective work.
- Evidence indicating the probable filing of claims by other parties against Contractor which may adversely affect the City.
- Failure of Contractor to make payments due to subcontractors, material suppliers, or employees.
- Damage to the City or a third party.

The submission of any request for payment shall be deemed a waiver and release by Contractor of all liens and claims with respect to the work and period to which such payment request pertains except as specifically reserved and noted on such request.

Article 5. Appropriation of Funds

Notwithstanding any other provision of this Agreement, if funds for the continued fulfillment of this Agreement by the City are at any time not forthcoming or are insufficient, through failure of any entity, including the City itself, to appropriate funds or otherwise, then the City shall have the right to terminate this Agreement without penalty.

Article 6. Performance and Payment Bond

Contractor shall, within ten (10) days of the approval of this Agreement by the Common Council of the City of Sheboygan, provide the City with a Performance Bond and a Payment Bond in the amount of one hundred percent (100%) of the contract amount.

Failure by Contractor to perform the work in a timely or satisfactory fashion may result in forfeiture of Contractor's Performance Bond.

If the Surety on any bond furnished by Contractor becomes a party to supervision or liquidation, or its right to do business in the State of Wisconsin is terminated, Contractor shall, within thirty (30) calendar days thereafter, substitute another bond or surety, both of which must be acceptable to the City.

Article 7. Schedule

Contractor shall begin the Services as soon as is practicable after this Agreement is approved by the Common Council of the City of Sheboygan and shall continue the prosecution of the Services as quickly as is practicable until the Services are completed. Contractor shall complete the services by December 15, 2019 or within such extra time as may have been allowed by a mutually agreed extension.

The Parties agree that no charges or claims for damages shall be made by Contractor for any delays or hindrances, from any cause whatsoever, during the progress of any portion of the services specified in the Agreement. Such delays or hindrances, if any, may be compensated for by an extension of time for a reasonable period as may be mutually agreed upon between the Parties, it being understood however, that permitting Contractor to proceed to complete any service, or any part of the services / project, after the date to which the time of completion may have been extended shall, in no way operate as a waiver on the part of the City of any of its rights herein.

Article 8. Quality of Materials

All materials used by Contractor shall be new, newest model year, and free from defects. Items which are used, demonstrators, obsolete, seconds, of which have been discontinued are unacceptable without prior written approval by the City.

Article 9. Safety Requirements

Contractor shall be responsible for the safety of employees at all times and shall provide all equipment necessary to insure their safety. Contractor shall ensure the enforcement of all applicable safety rules, regulations, ordinances and laws, whether federal, state, or local. Contractor's Superintendent of Safety shall make daily inspections upon the arrival and leaving of the site at the close of each workday.

Article 10. Open Records

Both parties understand that the City is bound by the Wisconsin Public Records Law and, as such, this contract is subject to that law. Contractor acknowledges that it is obligated to assist the City in retaining and producing records that are subject to Wisconsin Public Records Law, and that the failure to do so shall constitute a material breach of the contract, and that Contractor must defend and hold the City harmless from liability under that law. Except as otherwise authorized, those records shall be maintained for a period of seven (7) years after receipt of final payment under the Agreement.

Article 11. Termination

The City may terminate or suspend performance of this Agreement at the City's prerogative at any time upon written notice to Contractor. Contractor shall terminate or suspend performance of the Services on a schedule acceptable to the City and the City shall pay Contractor for all the Services performed up to the date that written notice is received, plus reasonable termination or suspension expenses. Upon restart, an equitable adjustment shall be made to Contractor's compensation and the schedule of services.

If Contractor defaults or fails to fulfill in a timely and proper manner its obligations pursuant to this Agreement, the City may, seven (7) days after written notice has been delivered to Contractor, and without prejudice to any other remedy it may have, make good such deficiencies and may deduct the cost thereof from the payment then or thereafter due to Contractor. In the alternative the City may, at its option, terminate this Agreement and take possession of the site and of all materials, equipment, tools, and construction equipment and machinery thereon owned by Contractor, and may finish the project by whatever method it may deem expedient. In case the expenses incurred by the City (including payments previously made to Contractor) shall be less than the sum which

would have been payable under the Agreement if it had been completed by Contractor, Contractor shall be entitled to receive the difference. However, in case such expense shall exceed the sum which would have been payable under the Agreement, Contractor will be liable and shall pay to the City the amount of said excess. By taking over prosecution of the work, the City does not forfeit the right to recover damages from Contractor or its surety for failure to complete the work in the time specified.

Article 12. Default

If Contractor breaches this Agreement or fails to perform the work in an acceptable manner, it shall be considered in default. Any one or more of the following will be considered a default:

- Failure to begin the work under this Agreement within the time specified.
- Failure to perform the work with sufficient supervision, workers, equipment and materials to insure prompt completion of said work within the time limits allowed.
- Unsuitable performance of the work as determined by City.
- Neglecting or refusing to remove defective materials or failure to perform anew such work as shall have been rejected.
- Discontinuing the prosecution of the work or any part of it.
- Inability to finance the work adequately.
- If, for any other reason, Contractor breaches this Agreement or fails to carry on the work in an acceptable manner.

The City shall send Contractor a written notice of default. If Contractor, within a period of seven (7) days after such notice, fails to remedy the default, then the City shall have full power and authority, without violation of the Agreement, to take the prosecution of the work out of the hands of Contractor, as set forth in this Agreement.

Article 13. Identity of Contractor

Contractor acknowledges that one of the primary reasons for its selection by the City to perform the Services is the qualifications and experience of Contractor. Contractor thus agrees that the Services to be performed pursuant to this Agreement shall be performed by Contractor. Contractor shall not subcontract any part of the Services without the prior written permission of the City. The City's project manager shall have the ability to provide this written permission. The City reserves the right to reject any of the Contractor's personnel or proposed outside professional sub-consultants, and the City reserves the right to request that acceptable replacement personnel be assigned to the project.

Article 14. Independent Contractor Status

During the entire term of this Agreement, Contractor shall be an independent contractor, and in no event shall any of its personnel, agents or sub-contractors be construed to be, or represent themselves to be, employees of the City. Contractor shall be solely responsible for the payment and reporting of all employee and employer taxes, including social security, unemployment, and any other federal, state, or local taxes required to be withheld from employees or payable on behalf of its employees.

Article 15. Indemnification

Contractor shall indemnify, defend, and hold the City—including its Officials, Agents, and Employees—free and harmless from all liability, including, but not limited to, losses, damages, costs, attorney’s fees, expenses, causes of action, claims, or judgments resulting from claimed injury, death, damage to property, or loss of use of property or any person or legal entity arising out of or in any way connected with the performance of work or work to be performed under this Agreement.

Contractor shall reimburse the City for any costs, expenses, judgments, and attorney’s fees paid or incurred, by or on behalf of the City, its Officials, Agents, or Employees, or paid for on behalf of the City, its Officials, Agents, or Employees by insurance purchased or self-insurance provided by the City arising out of or in any way connected with the performance of work or work to be performed under this Agreement.

Contractor shall further indemnify, defend, and hold harmless the City, its Officials, Agents, and Employees from liability or claims for any injuries to or death of Contractor’s employees (or the employees of any authorized subcontractor) arising out of or in any way connected with the work or work to be performed under this Agreement, including protection against any claim of the contractor or subcontractor for any payments under any worker’s compensation law or any expenses of or any payments made by any worker’s compensation insurance carrier on behalf of said contractor or sub-contractor and the contractor shall indemnify the City for any costs, expenses, judgments, and attorney’s fees with respect to any above referenced workers’ compensation claims incurred or paid by the City or paid on its behalf or on behalf of its Officials, Agents, or Employees by insurance purchased or self-insurance provided by the City of Sheboygan.

Article 16. Insurance

Contractor shall not commence work under this Agreement until it has obtained all insurance required under this Article. Additionally, Contractor shall not allow any approved subcontractor to commence work on its subcontract until the subcontractor has obtained all insurance required under this Article.

During the performance of any and all Services under this Agreement, Contractor shall maintain the following insurance in full force and effect, and shall provide proof of insurance to the Purchasing Agent listing the City of Sheboygan as an additional insured:

- a. **Workers’ Compensation Insurance** — Contractor shall acquire and maintain, for the duration of the Agreement, Workers’ Compensation Insurance that meets all statutory requirements. In the event this Agreement authorizes any work to be sublet, Contractor shall require any subcontractor to similarly provide Workers’ Compensation Insurance in accordance with all statutory requirements.
- b. **Commercial General Liability Insurance** — Contractor shall acquire and maintain, for the duration of the Agreement, Commercial General Liability Insurance with a policy limit of at least \$1,000,000 per occurrence and \$2,000,000 in the aggregate.

All insurance must be primary and non-contributory to any insurance or self-insurance carried by the City.

Approval of the insurance by the City shall not relieve or decrease the extent to which Contractor may be held responsible for payment of damages resulting from Contractor's provision of the Services or its operations under this Agreement. If Contractor fails or refuses to procure or maintain the insurance required by these provisions, or fails or refuses to furnish the City the required proof that the insurance has been procured and is in force and paid for, the City shall have the right at its election to terminate the Agreement.

Article 17. Conflict of Interest

Contractor declares that it has no present interest, nor shall it acquire any interest, direct or indirect, which would conflict with the performance of Services under this Agreement. Contractor agrees that no person having any such interest shall be employed in the performance of this Agreement.

Article 18. Waiver

No failure of either party to enforce a term of this Agreement against the other shall be construed as a waiver of that term, nor shall it in any way affect the party's right to enforce that term. No waiver by any party of any term of this Agreement shall be considered to be a waiver of any other term or breach thereof.

Article 19. Severability

The invalidity, illegality or unenforceability of any provision of this Agreement or the occurrence of any event rendering any portion or provision of this Agreement void shall in no way affect the validity or enforceability of any other portion or provision of this Agreement. Any void provision shall be deemed severed from this Agreement, and the balance of the Agreement shall be construed and enforced as if it did not contain the particular provision to be held void. The parties further agree to amend this Agreement to replace any stricken provision with a valid provision that comes as close as possible to the intent of the stricken provision. The provisions of this Article shall not prevent this entire Agreement from being void should a provision which is of the essence of this Agreement be determined void.

Article 20. Assignment

Neither the City nor Contractor shall assign any rights or duties under this Agreement without the prior written consent of the other party.

Article 21. Third Party Rights

Nothing in this Agreement shall be construed to give any rights or benefits to anyone other than the City and Contractor.

Article 22. Governing Law and Venue

This Agreement shall be governed by the laws of the State of Wisconsin. Venue of any disputes arising under this Agreement shall be in the Sheboygan County Circuit Court, Wisconsin.

Article 23. Non-Discrimination

In connection with the performance of work under this Agreement, Contractor agrees not to discriminate against any employee or applicant for employment because of age, race, religion, color, handicap, sex, physical condition, developmental disability (as defined in Wis. Stat. 51.01(5)), sexual orientation (as defined in Wis. Stat. 111.32(13m)), or national origin. This provision shall include, but not be limited to, the following: employment, upgrading, demotion or transfer, recruitment or recruitment advertising, layoff or termination, rates of pay or other forms of compensation, and selection for training, including apprenticeship. Contractor further agrees to take affirmative action to ensure equal employment opportunities.

Article 24. Compliance with Laws

In performing the Services under this Agreement, Contractor shall comply with any and all applicable federal, state and local statutes, ordinances, plans, and regulations.

The City reserves the right to cancel this Agreement if Contractor fails to follow the requirements of Wis. Stat. 77.66 and related statutes regarding certification for collection of sales and use tax. The City also reserves the right to cancel this Agreement with any state or federally debarred contractor.

Contractor shall have any and all licenses and permits required to perform the work specified, and shall furnish proof of such licensing authorization and permits upon request.

Article 25. Notices

Any notice required by this Agreement shall be made in writing to the individuals/addresses specified below:

City:

Contractor:

City Clerk	Andy Chappa
City of Sheboygan	A Chappa Construction, LLC
828 Center Ave.	443 North Main Street
Sheboygan, Wisconsin 53083	Sheboygan Falls, Wisconsin 53085

Nothing contained in this Article shall be construed to restrict the transmission of routine communications between representatives of the City and Contractor.

Article 26. Intent to be Bound

The City and Contractor each binds itself and its successors, executors, administrators, permitted assigns, legal representatives and, in the case of a partnership, its partners to the other party to this Agreement, and to the successors, executors, administrators, permitted assigns, legal representatives and partners of such other party in respect to all provisions of this Agreement.

Article 27. Force Majeure

Neither party shall be in default by reason of any failure in performance of this Agreement in accordance with reasonable control and without fault or negligence on their part. Such causes may include, but are not restricted to, acts of nature or the public enemy, acts of the government in either

its sovereign or contractual capacity, fires, floods, epidemics, quarantine restrictions, strikes, freight embargoes, and unusually severe weather. In every case, the failure to perform must be beyond the reasonable control and without the fault or negligence of the party.

Article 28. Integration and Modification

This Agreement, including all Exhibits incorporated by reference, represents the entire and integrated agreement between the City and the Contractor. It supersedes all prior and contemporaneous communications, representations and agreements, whether oral or written, relating to the subject matter of this Agreement. This Agreement may be modified only by a written amendment signed by both parties hereto.

Article 29. Non-Collusion

Contractor is certifying, under penalty of perjury, that to the best of its knowledge and belief:

- a. The price in its response was arrived at independently, without collusion, consultation, communication, or agreement, for the purpose of restricting competition as to any other matter relating to such prices with any other competitor.
- b. No attempt was made to induce any other person, partnership, or corporation to submit or not submit a response to the City regarding the Services for the purpose of restricting competition.

Article 30. Other Provisions

- a. Material Safety Data Sheet. If any item(s) on an order(s) resulting from this Agreement is a hazardous chemical, as defined under 29 C.F.R. 1910.1200, Contractor shall provide one (1) copy of a Material Safety Data Sheet for each item with the shipped container(s) and one (1) copy with the invoice(s).
- b. Advertising and News Releases. Reference to or use of the City, or any of its departments, officials, or employees, for commercial promotion is prohibited. News releases pertaining to this procurement shall not be made without prior approval of the City. Release of broadcast e-mails pertaining to this procurement shall not be made without prior written authorization of the City.
- c. Foreign Corporation. A foreign corporation (any corporation other than a Wisconsin corporation) which becomes a party to this Agreement is required to conform to all the requirements of Wis. Stat. 180 relating to a foreign corporation, and must possess a certificate of authority from the Wisconsin Department of Financial Institutions, unless the corporation is transacting business in interstate commerce or is otherwise exempt from the requirement of obtaining a certificate of authority.
- d. Neither Party the Drafter. Despite the possibility that one party or its representatives may have prepared the initial draft of this Agreement (or any provision thereof), or played a greater role in the preparation of subsequent drafts, the parties agree that neither of them shall be deemed the drafter of this Agreement.

e. Authority. Each person executing this Agreement on behalf of a party hereto represents and warrants to the other party: That the execution and delivery of this Agreement has been duly authorized, that the person or persons executing this Agreement have the full power, authority, and right to do so, and that such execution is sufficient and legally binding on such party to enable this Agreement to be enforceable in accordance with its terms.

IN WITNESS WHEREOF, the parties hereto have caused this Agreement to be executed the day and year first written above.

CITY OF SHEBOYGAN, WISCONSIN

BY: 
Michael J. Vandersteen, Mayor

ATTEST: 
Meredith DeBruin, City Clerk

DATE: 11-19-19

CONTRACTOR

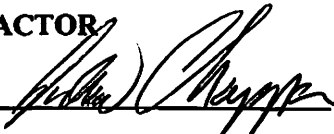
BY: 

ATTEST: _____

DATE: 11-19-19

Exhibit A

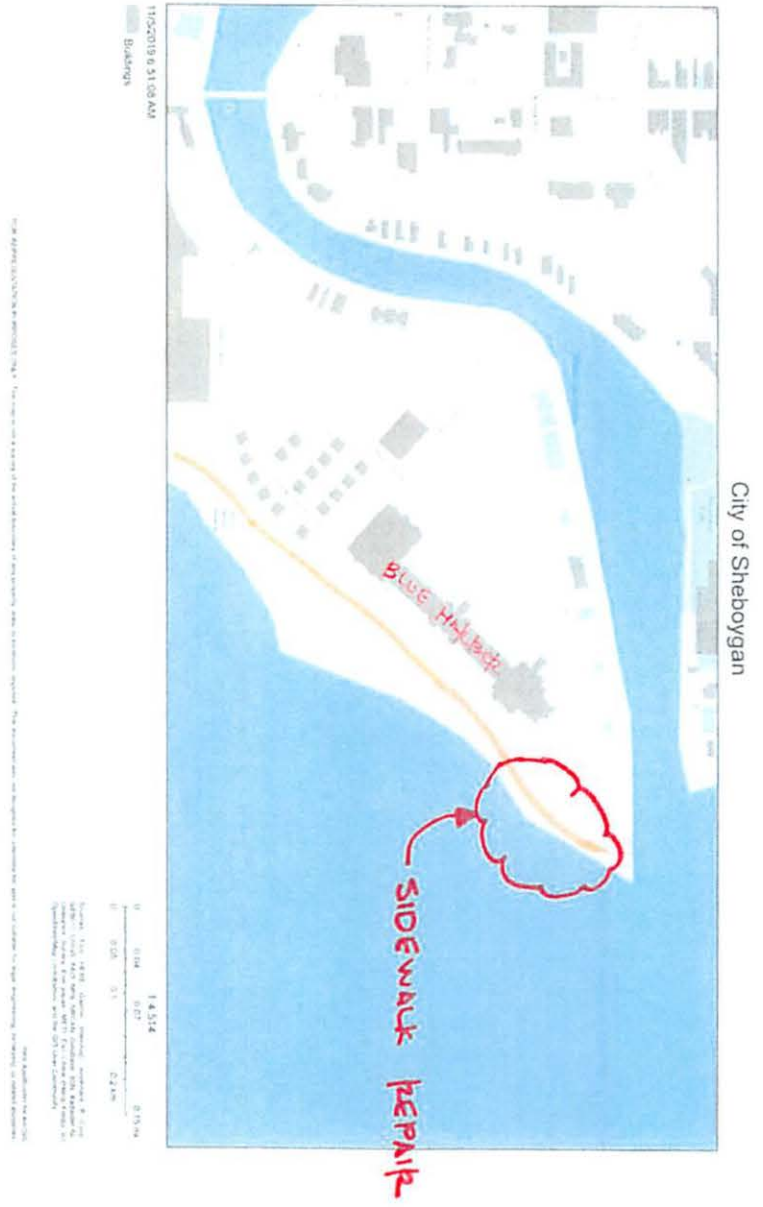

VIII

R. C. No. _____ - 19 - 20. By PUBLIC WORKS COMMITTEE. November 18, 2019.

Your Committee to whom was referred DIRECT REFERRAL Res. No. 112-19-20 by Alderpersons Wolf and Sorenson authorizing the appropriate City officials to enter into a contract for the remodeling of the Men's and Women's bathroom facilities at the Municipal Service Building; recommends adopting the Resolution.

res

_____ Committee

I HEREBY CERTIFY that the foregoing Committee Report was duly accepted and adopted by the Common Council of the City of Sheboygan, Wisconsin, on the _____ day of _____, 20____.

Dated _____ 20____. _____, City Clerk

Approved _____ 20____. _____, Mayor



DIRECT REFERRAL TO PUBLIC WORKS COMMITTEE

Res. No. 112 - 19 - 20. By Alderpersons Wolf and Sorenson.
November 12, 2019.

A RESOLUTION authorizing the appropriate City officials to enter into a contract for the remodeling of the Men's and Women's bathroom facilities at the Municipal Service Building.

WHEREAS, the majority of the bathroom facilities (including the shower facilities) at the Municipal Services Building are original to the building, which was constructed in 1966, and are in need of an update; and

WHEREAS, the Department of Public Works included funding in the 2019 Capital Improvements Program for a new women's locker room and to renovate the men's bathroom; and

WHEREAS, the City of Sheboygan has obtained architectural and engineering services related to this project, and issued a Request for Bids for the project based upon the plans and specifications delivered to the City by Abacus Architects; and

WHEREAS, following a review of the bids received, it has been determined that the lowest bid, in the amount of \$209,832, submitted by Zeise Construction Inc. of Green Bay, Wisconsin, meets or exceeds all of the specifications; and

WHEREAS, as part of this renovation, Staff believes it is in the best interest of the City to contract for additional improvements that are outside the general construction contract but related to the project - namely, roof patching, connection to the digital HVAC Controls system already present at the Municipal Service Building, and furnishing fire extinguishers - at a cost of \$9,765, which are being included in this Resolution to avoid any appearance of serial contracting.

NOW, THEREFORE, BE IT RESOLVED: That the appropriate City officials are hereby authorized to enter into a contract with Zeise Construction Inc. in substantially similar form to that attached in the amount of \$209,832.00.

BE IT FURTHER RESOLVED: That Staff is authorized to expend \$9,765.00 for necessary roof patching, purchasing four lockers, connecting to the digital HVAC Controls system already present at the Municipal Services Building, and furnishing fire extinguishers.

*Public Works
adopt*

BE IT FURTHER RESOLVED: That the appropriate City officials are hereby authorized to draw funds in the amount of \$219,597.00 from Account No. 40033110-621200 (Capital Project Fund-Building Improvements) pursuant to the contract.

I HEREBY CERTIFY that the foregoing Resolution was duly passed by the Common Council of the City of Sheboygan, Wisconsin, on the _____ day of _____, 20____.

Dated _____ 20____. _____, City Clerk

Approved _____ 20____. _____, Mayor

**AGREEMENT
BETWEEN THE CITY OF SHEBOYGAN, WISCONSIN AND
ZEISE CONSTRUCTION, INC.**

**REGARDING REMODELING THE MEN’S AND WOMEN’S BATHROOM FACILITIES
AT THE MUNICIPAL SERVICES BUILDING**

This Agreement (“Agreement”) is made and entered into effective this ____ day of _____, 2019 (the “Effective Date”), by and between the City of Sheboygan (the “City”), a municipal corporation, and Zeise Construction, Inc. (“Contractor”).

WITNESSETH:

WHEREAS, the bathroom facilities at the Municipal Services Building in the City of Sheboygan, located at 2026 New Jersey Ave. are in need of renovation; and

WHEREAS, the City solicited bids for the necessary renovations; and

WHEREAS, Contractor was identified as the lowest responsive and responsible bidder; and

WHEREAS, Contractor is willing and able to complete the renovations under the terms set forth in this Agreement.

NOW, THEREFORE, in consideration of the mutual covenants herein contained, the parties hereto agree as follows:

Article 1. Scope of Services

Contractor shall provide all services and materials necessary to renovate the men’s and women’s bathroom facilities at the Municipal Services Building in the City of Sheboygan (located at 2026 New Jersey Ave.) (the “Services”) pursuant to the Plans and Specifications attached to this Agreement as Exhibit A, as modified by Addendum No. 1 (attached to this Agreement as Exhibit B), Addendum No. 2 (attached to this Agreement as Exhibit C), and Addendum No. 3 (attached to this Agreement as Exhibit D) (collectively the “Plans and Specifications”).

Contractor shall be responsible for obtaining any and all applicable City permits and paying any and all applicable permit fees prior to beginning work.

Contractor shall be responsible for furnishing, erecting, and maintaining suitable barricades, warning signs, flashers, fencing, and other protective equipment to properly protect and safeguard its personnel and the public during all phases of the Services.

Contractor shall give notice to the proper authorities in charge of streets, gas and water pipes, electric and other conduits, railroad, poles, catch basins, sewers, and all other property that may be affected by Contractor’s operations, at least three (3) business days before beginning operations.

Contractor shall not hinder or interfere with any persons in the protection of such property or with the operations of utilities at any time. Contractor shall protect such utilities from damage and unnecessary exposure. The cost of repairing any damage to utilities shall be the responsibility of Contractor.

Article 2. Standard of Care

Contractor shall be responsible for completion of the Services in a manner consistent with that degree of care and skill ordinarily exercised by members of the same profession currently practicing under similar circumstances (“Standard of Care”). The City shall be the sole judge of the adequacy of Contractor’s work in meeting the Standard of Care; however, the City shall not unreasonably withhold its approval as to the adequacy of Contractor’s performance. Upon notice to Contractor, Contractor will, without additional compensation, correct or replace any and all Services not meeting the Standard of Care.

Article 3. Responsibilities of the City

The City designates Michael Willmas as its designated project manager for purposes of this Agreement.

Article 4. Compensation

The City shall pay Contractor for all fees and expenses in an amount not to exceed Two Hundred Nine Thousand Eight Hundred Thirty Two Dollars (\$209,832).

Invoices may be sent via first class mail postage prepaid or via email. Contractor shall submit AIA Form G702, G703 with Waiver of Lien. These shall be reviewed by the City’s Architect prior to the City making payment toward the invoice.

Assuming all documentation is approved, payment will be remitted to Contractor within forty-five days of receipt of invoice. Contractor shall submit an invoice to the City on a monthly basis and shall be based on the percentage complete of the Services described in Article 1. The invoice shall be sent to:

Michael Willmas
Department of Public Works
City of Sheboygan
2026 New Jersey Ave.
Sheboygan, Wisconsin 53081
michael.willmas@sheboyganwi.gov

Additional services not set forth in Article 1, or changes in the Services must be authorized in writing by the City or its designated project manager prior to such work being performed, or expenses incurred. The City shall not make payment for any unauthorized work or expenses.

The City may withhold payment, in whole or in part, to the extent necessary to protect itself from a loss on account of any of the following:

- Defective work.
- Evidence indicating the probable filing of claims by other parties against Contractor which may adversely affect the City.
- Failure of Contractor to make payments due to subcontractors, material suppliers, or employees.
- Damage to the City or a third party.

The submission of any request for payment shall be deemed a waiver and release by Contractor of all liens and claims with respect to the work and period to which such payment request pertains except as specifically reserved and noted on such request.

Article 5. Appropriation of Funds

Notwithstanding any other provision of this Agreement, if funds for the continued fulfillment of this Agreement by the City are at any time not forthcoming or are insufficient, through failure of any entity, including the City itself, to appropriate funds or otherwise, then the City shall have the right to terminate this Agreement without penalty.

Article 6. Performance and Payment Bond

Contractor shall, within ten (10) days of the approval of this Agreement by the Common Council of the City of Sheboygan, provide the City with a Performance Bond and a Payment Bond in the amount of one hundred percent (100%) of the contract amount.

Failure by Contractor to perform the work in a timely or satisfactory fashion may result in forfeiture of Contractor's Performance Bond.

If the Surety on any bond furnished by Contractor becomes a party to supervision or liquidation, or its right to do business in the State of Wisconsin is terminated, Contractor shall, within thirty (30) calendar days thereafter, substitute another bond or surety, both of which must be acceptable to the City.

Article 7. Schedule

Contractor shall begin the Services as soon as is practicable after this Agreement is approved by the Common Council of the City of Sheboygan and shall continue the prosecution of the Services as quickly as is practicable until the Services are completed. Contractor shall complete the services pursuant to the Schedule attached to this Agreement as Exhibit E or within such extra time as may have been allowed by a mutually agreed extension.

The Parties agree that no charges or claims for damages shall be made by Contractor for any delays or hindrances, from any cause whatsoever, during the progress of any portion of the services specified in the Agreement. Such delays or hindrances, if any, may be compensated for by an extension of time for a reasonable period as may be mutually agreed upon between the Parties, it being understood however, that permitting Contractor to proceed to complete any service, or any part of the services / project, after the date to which the time of completion may have been extended shall, in no way operate as a waiver on the part of the City of any of its rights herein.

Article 8. Quality of Materials

All materials used by Contractor shall be new, newest model year, and free from defects. Items which are used, demonstrators, obsolete, seconds, of which have been discontinued are unacceptable without prior written approval by the City.

Article 9. Safety Requirements

Contractor shall be responsible for the safety of employees at all times and shall provide all equipment necessary to insure their safety. Contractor shall ensure the enforcement of all applicable safety rules, regulations, ordinances and laws, whether federal, state, or local. Contractor's Superintendent of Safety shall make daily inspections upon the arrival and leaving of the site at the close of each workday.

Article 10. Open Records

Both parties understand that the City is bound by the Wisconsin Public Records Law and, as such, this contract is subject to that law. Contractor acknowledges that it is obligated to assist the City in retaining and producing records that are subject to Wisconsin Public Records Law, and that the failure to do so shall constitute a material breach of the contract, and that Contractor must defend and hold the City harmless from liability under that law. Except as otherwise authorized, those records shall be maintained for a period of seven (7) years after receipt of final payment under the Agreement.

Article 11. Termination

The City may terminate or suspend performance of this Agreement at the City's prerogative at any time upon written notice to Contractor. Contractor shall terminate or suspend performance of the Services on a schedule acceptable to the City and the City shall pay Contractor for all the Services performed up to the date that written notice is received, plus reasonable termination or suspension expenses. Upon restart, an equitable adjustment shall be made to Contractor's compensation and the schedule of services.

If Contractor defaults or fails to fulfill in a timely and proper manner its obligations pursuant to this Agreement, the City may, seven (7) days after written notice has been delivered to Contractor, and without prejudice to any other remedy it may have, make good such deficiencies and may deduct the cost thereof from the payment then or thereafter due to Contractor. In the alternative the City may, at its option, terminate this Agreement and take possession of the site and of all materials, equipment, tools, and construction equipment and machinery thereon owned by Contractor, and may finish the project by whatever method it may deem expedient. In case the expenses incurred by the City (including payments previously made to Contractor) shall be less than the sum which would have been payable under the Agreement if it had been completed by Contractor, Contractor shall be entitled to receive the difference. However, in case such expense shall exceed the sum which would have been payable under the Agreement, Contractor will be liable and shall pay to the City the amount of said excess. By taking over prosecution of the work, the City does not forfeit the right to recover damages from Contractor or its surety for failure to complete the work in the time specified.

Article 12. Default

If Contractor breaches this Agreement or fails to perform the work in an acceptable manner, it shall be considered in default. Any one or more of the following will be considered a default:

- Failure to begin the work under this Agreement within the time specified.
- Failure to perform the work with sufficient supervision, workers, equipment and materials to insure prompt completion of said work within the time limits allowed.
- Unsuitable performance of the work as determined by City.
- Neglecting or refusing to remove defective materials or failure to perform anew such work as shall have been rejected.
- Discontinuing the prosecution of the work or any part of it.
- Inability to finance the work adequately.
- If, for any other reason, Contractor breaches this Agreement or fails to carry on the work in an acceptable manner.

The City shall send Contractor a written notice of default. If Contractor, within a period of seven (7) days after such notice, fails to remedy the default, then the City shall have full power and authority, without violation of the Agreement, to take the prosecution of the work out of the hands of Contractor, as set forth in this Agreement.

Article 13. Identity of Contractor

Contractor acknowledges that one of the primary reasons for its selection by the City to perform the Services is the qualifications and experience of Contractor. Contractor thus agrees that the Services to be performed pursuant to this Agreement shall be performed by Contractor. Contractor shall not subcontract any part of the Services without the prior written permission of the City. The City's project manager shall have the ability to provide this written permission. The City reserves the right to reject any of the Contractor's personnel or proposed outside professional sub-consultants, and the City reserves the right to request that acceptable replacement personnel be assigned to the project.

Article 14. Independent Contractor Status

During the entire term of this Agreement, Contractor shall be an independent contractor, and in no event shall any of its personnel, agents or sub-contractors be construed to be, or represent themselves to be, employees of the City. Contractor shall be solely responsible for the payment and reporting of all employee and employer taxes, including social security, unemployment, and any other federal, state, or local taxes required to be withheld from employees or payable on behalf of its employees.

Article 15. Indemnification

Contractor shall indemnify, defend, and hold the City—including its Officials, Agents, and Employees—free and harmless from all liability, including, but not limited to, losses, damages, costs, attorney's fees, expenses, causes of action, claims, or judgments resulting from claimed injury, death, damage to property, or loss of use of property or any person or legal entity arising out of or in any way connected with the performance of work or work to be performed under this Agreement.

Contractor shall reimburse the City for any costs, expenses, judgments, and attorney's fees paid or incurred, by or on behalf of the City, its Officials, Agents, or Employees, or paid for on behalf of the City, its Officials, Agents, or Employees by insurance purchased or self-insurance provided by the City arising out of or in any way connected with the performance of work or work to be performed under this Agreement.

Contractor shall further indemnify, defend, and hold harmless the City, its Officials, Agents, and Employees from liability or claims for any injuries to or death of Contractor's employees (or the employees of any authorized subcontractor) arising out of or in any way connected with the work or work to be performed under this Agreement, including protection against any claim of the contractor or subcontractor for any payments under any worker's compensation law or any expenses of or any payments made by any worker's compensation insurance carrier on behalf of said contractor or sub-contractor and the contractor shall indemnify the City for any costs, expenses, judgments, and attorney's fees with respect to any above referenced workers' compensation claims incurred or paid by the City or paid on its behalf or on behalf of its Officials, Agents, or Employees by insurance purchased or self-insurance provided by the City of Sheboygan.

Article 16. Insurance

Contractor shall not commence work under this Agreement until it has obtained all insurance required under this Article. Additionally, Contractor shall not allow any approved subcontractor to commence work on its subcontract until the subcontractor has obtained all insurance required under this Article.

During the performance of any and all Services under this Agreement, Contractor shall maintain the following insurance in full force and effect, and shall provide proof of insurance to the Purchasing Agent listing the City of Sheboygan as an additional insured:

- a. **Workers' Compensation Insurance** — Contractor shall acquire and maintain, for the duration of the Agreement, Workers' Compensation Insurance that meets all statutory requirements. In the event this Agreement authorizes any work to be sublet, Contractor shall require any subcontractor to similarly provide Workers' Compensation Insurance in accordance with all statutory requirements.
- b. **Commercial General Liability Insurance** — Contractor shall acquire and maintain, for the duration of the Agreement, Commercial General Liability Insurance with a policy limit of at least \$1,000,000 per occurrence and \$2,000,000 in the aggregate.

All insurance must be primary and non-contributory to any insurance or self-insurance carried by the City.

Approval of the insurance by the City shall not relieve or decrease the extent to which Contractor may be held responsible for payment of damages resulting from Contractor's provision of the Services or its operations under this Agreement. If Contractor fails or refuses to procure or maintain the insurance required by these provisions, or fails or refuses to furnish the City the

required proof that the insurance has been procured and is in force and paid for, the City shall have the right at its election to terminate the Agreement.

Article 17. Conflict of Interest

Contractor declares that it has no present interest, nor shall it acquire any interest, direct or indirect, which would conflict with the performance of Services under this Agreement. Contractor agrees that no person having any such interest shall be employed in the performance of this Agreement.

Article 18. Waiver

No failure of either party to enforce a term of this Agreement against the other shall be construed as a waiver of that term, nor shall it in any way affect the party's right to enforce that term. No waiver by any party of any term of this Agreement shall be considered to be a waiver of any other term or breach thereof.

Article 19. Severability

The invalidity, illegality or unenforceability of any provision of this Agreement or the occurrence of any event rendering any portion or provision of this Agreement void shall in no way affect the validity or enforceability of any other portion or provision of this Agreement. Any void provision shall be deemed severed from this Agreement, and the balance of the Agreement shall be construed and enforced as if it did not contain the particular provision to be held void. The parties further agree to amend this Agreement to replace any stricken provision with a valid provision that comes as close as possible to the intent of the stricken provision. The provisions of this Article shall not prevent this entire Agreement from being void should a provision which is of the essence of this Agreement be determined void.

Article 20. Assignment

Neither the City nor Contractor shall assign any rights or duties under this Agreement without the prior written consent of the other party.

Article 21. Third Party Rights

Nothing in this Agreement shall be construed to give any rights or benefits to anyone other than the City and Contractor.

Article 22. Governing Law and Venue

This Agreement shall be governed by the laws of the State of Wisconsin. Venue of any disputes arising under this Agreement shall be in the Sheboygan County Circuit Court, Wisconsin.

Article 23. Non-Discrimination

In connection with the performance of work under this Agreement, Contractor agrees not to discriminate against any employee or applicant for employment because of age, race, religion, color, handicap, sex, physical condition, developmental disability (as defined in Wis. Stat. 51.01(5)), sexual orientation (as defined in Wis. Stat. 111.32(13m)), or national origin. This provision shall include, but not be limited to, the following: employment, upgrading, demotion or transfer, recruitment or recruitment advertising, layoff or termination, rates of pay or other forms of

compensation, and selection for training, including apprenticeship. Contractor further agrees to take affirmative action to ensure equal employment opportunities.

Article 24. Compliance with Laws

In performing the Services under this Agreement, Contractor shall comply with any and all applicable federal, state and local statutes, ordinances, plans, and regulations.

The City reserves the right to cancel this Agreement if Contractor fails to follow the requirements of Wis. Stat. 77.66 and related statutes regarding certification for collection of sales and use tax. The City also reserves the right to cancel this Agreement with any state or federally debarred contractor.

Contractor shall have any and all licenses and permits required to perform the work specified, and shall furnish proof of such licensing authorization and permits upon request.

Article 25. Notices

Any notice required by this Agreement shall be made in writing to the individuals/addresses specified below:

City:

Contractor:

City Clerk	John Gretzinger
City of Sheboygan	Zeise Construction
828 Center Ave.	901 Vanderbraak Street
Sheboygan, Wisconsin 53083	Green Bay, Wisconsin 54302

Nothing contained in this Article shall be construed to restrict the transmission of routine communications between representatives of the City and Contractor.

Article 26. Intent to be Bound

The City and Contractor each binds itself and its successors, executors, administrators, permitted assigns, legal representatives and, in the case of a partnership, its partners to the other party to this Agreement, and to the successors, executors, administrators, permitted assigns, legal representatives and partners of such other party in respect to all provisions of this Agreement.

Article 27. Force Majeure

Neither party shall be in default by reason of any failure in performance of this Agreement in accordance with reasonable control and without fault or negligence on their part. Such causes may include, but are not restricted to, acts of nature or the public enemy, acts of the government in either its sovereign or contractual capacity, fires, floods, epidemics, quarantine restrictions, strikes, freight embargoes, and unusually severe weather. In every case, the failure to perform must be beyond the reasonable control and without the fault or negligence of the party.

Article 28. Integration and Modification

This Agreement, including all Exhibits incorporated by reference, represents the entire and integrated agreement between the City and the Contractor. It supersedes all prior and contemporaneous communications, representations and agreements, whether oral or written, relating to the subject matter of this Agreement. This Agreement may be modified only by a written amendment signed by both parties hereto.

Article 29. Non-Collusion

Contractor is certifying, under penalty of perjury, that to the best of its knowledge and belief:

- a. The price in its bid was arrived at independently, without collusion, consultation, communication, or agreement, for the purpose of restricting competition as to any other matter relating to such prices with any other bidder, or with any other competitor.
- b. No attempt was made to induce any other person, partnership, or corporation to submit or not submit a bid for the purpose of restricting competition.

Article 30. Other Provisions

- a. Material Safety Data Sheet. If any item(s) on an order(s) resulting from this Agreement is a hazardous chemical, as defined under 29 C.F.R. 1910.1200, Contractor shall provide one (1) copy of a Material Safety Data Sheet for each item with the shipped container(s) and one (1) copy with the invoice(s).
- b. Advertising and News Releases. Reference to or use of the City, or any of its departments, officials, or employees, for commercial promotion is prohibited. News releases pertaining to this procurement shall not be made without prior approval of the City. Release of broadcast e-mails pertaining to this procurement shall not be made without prior written authorization of the City.
- c. Foreign Corporation. A foreign corporation (any corporation other than a Wisconsin corporation) which becomes a party to this Agreement is required to conform to all the requirements of Wis. Stat. 180 relating to a foreign corporation, and must possess a certificate of authority from the Wisconsin Department of Financial Institutions, unless the corporation is transacting business in interstate commerce or is otherwise exempt from the requirement of obtaining a certificate of authority.
- d. Neither Party the Drafter. Despite the possibility that one party or its representatives may have prepared the initial draft of this Agreement (or any provision thereof), or played a greater role in the preparation of subsequent drafts, the parties agree that neither of them shall be deemed the drafter of this Agreement.
- e. Authority. Each person executing this Agreement on behalf of a party hereto represents and warrants to the other party: That the execution and delivery of this Agreement has been duly authorized, that the person or persons executing this Agreement have the full power,

authority, and right to do so, and that such execution is sufficient and legally binding on such party to enable this Agreement to be enforceable in accordance with its terms.

IN WITNESS WHEREOF, the parties hereto have caused this Agreement to be executed the day and year first written above.

CITY OF SHEBOYGAN, WISCONSIN

CONTRACTOR

BY: _____
Michael J. Vandersteen, Mayor

BY: _____

ATTEST: _____
Meredith DeBruin, City Clerk

ATTEST: _____

DATE: _____

DATE: _____

CITY OF SHEBOYGAN DPW RENOVATION

2026 NEW JERSEY AVE, SHEBOYGAN, WI 53081

LOCKER ROOM RENOVATIONS



REVISIONS:

NO. DATE
1 10/20/2019
2 11/15/2019
3 12/10/2019
4 01/15/2020
5 02/10/2020
6 03/10/2020
7 04/10/2020
8 05/10/2020
9 06/10/2020
10 07/10/2020
11 08/10/2020
12 09/10/2020
13 10/10/2020
14 11/10/2020
15 12/10/2020
16 01/10/2021
17 02/10/2021
18 03/10/2021
19 04/10/2021
20 05/10/2021
21 06/10/2021
22 07/10/2021
23 08/10/2021
24 09/10/2021
25 10/10/2021
26 11/10/2021
27 12/10/2021
28 01/10/2022
29 02/10/2022
30 03/10/2022
31 04/10/2022
32 05/10/2022
33 06/10/2022
34 07/10/2022
35 08/10/2022
36 09/10/2022
37 10/10/2022
38 11/10/2022
39 12/10/2022
40 01/10/2023
41 02/10/2023
42 03/10/2023
43 04/10/2023
44 05/10/2023
45 06/10/2023
46 07/10/2023
47 08/10/2023
48 09/10/2023
49 10/10/2023
50 11/10/2023
51 12/10/2023
52 01/10/2024
53 02/10/2024
54 03/10/2024
55 04/10/2024
56 05/10/2024
57 06/10/2024
58 07/10/2024
59 08/10/2024
60 09/10/2024
61 10/10/2024
62 11/10/2024
63 12/10/2024
64 01/10/2025
65 02/10/2025
66 03/10/2025
67 04/10/2025
68 05/10/2025
69 06/10/2025
70 07/10/2025
71 08/10/2025
72 09/10/2025
73 10/10/2025
74 11/10/2025
75 12/10/2025
76 01/10/2026
77 02/10/2026
78 03/10/2026
79 04/10/2026
80 05/10/2026
81 06/10/2026
82 07/10/2026
83 08/10/2026
84 09/10/2026
85 10/10/2026
86 11/10/2026
87 12/10/2026
88 01/10/2027
89 02/10/2027
90 03/10/2027
91 04/10/2027
92 05/10/2027
93 06/10/2027
94 07/10/2027
95 08/10/2027
96 09/10/2027
97 10/10/2027
98 11/10/2027
99 12/10/2027
100 01/10/2028
101 02/10/2028
102 03/10/2028
103 04/10/2028
104 05/10/2028
105 06/10/2028
106 07/10/2028
107 08/10/2028
108 09/10/2028
109 10/10/2028
110 11/10/2028
111 12/10/2028
112 01/10/2029
113 02/10/2029
114 03/10/2029
115 04/10/2029
116 05/10/2029
117 06/10/2029
118 07/10/2029
119 08/10/2029
120 09/10/2029
121 10/10/2029
122 11/10/2029
123 12/10/2029
124 01/10/2030
125 02/10/2030
126 03/10/2030
127 04/10/2030
128 05/10/2030
129 06/10/2030
130 07/10/2030
131 08/10/2030
132 09/10/2030
133 10/10/2030
134 11/10/2030
135 12/10/2030
136 01/10/2031
137 02/10/2031
138 03/10/2031
139 04/10/2031
140 05/10/2031
141 06/10/2031
142 07/10/2031
143 08/10/2031
144 09/10/2031
145 10/10/2031
146 11/10/2031
147 12/10/2031
148 01/10/2032
149 02/10/2032
150 03/10/2032
151 04/10/2032
152 05/10/2032
153 06/10/2032
154 07/10/2032
155 08/10/2032
156 09/10/2032
157 10/10/2032
158 11/10/2032
159 12/10/2032
160 01/10/2033
161 02/10/2033
162 03/10/2033
163 04/10/2033
164 05/10/2033
165 06/10/2033
166 07/10/2033
167 08/10/2033
168 09/10/2033
169 10/10/2033
170 11/10/2033
171 12/10/2033
172 01/10/2034
173 02/10/2034
174 03/10/2034
175 04/10/2034
176 05/10/2034
177 06/10/2034
178 07/10/2034
179 08/10/2034
180 09/10/2034
181 10/10/2034
182 11/10/2034
183 12/10/2034
184 01/10/2035
185 02/10/2035
186 03/10/2035
187 04/10/2035
188 05/10/2035
189 06/10/2035
190 07/10/2035
191 08/10/2035
192 09/10/2035
193 10/10/2035
194 11/10/2035
195 12/10/2035
196 01/10/2036
197 02/10/2036
198 03/10/2036
199 04/10/2036
200 05/10/2036
201 06/10/2036
202 07/10/2036
203 08/10/2036
204 09/10/2036
205 10/10/2036
206 11/10/2036
207 12/10/2036
208 01/10/2037
209 02/10/2037
210 03/10/2037
211 04/10/2037
212 05/10/2037
213 06/10/2037
214 07/10/2037
215 08/10/2037
216 09/10/2037
217 10/10/2037
218 11/10/2037
219 12/10/2037
220 01/10/2038
221 02/10/2038
222 03/10/2038
223 04/10/2038
224 05/10/2038
225 06/10/2038
226 07/10/2038
227 08/10/2038
228 09/10/2038
229 10/10/2038
230 11/10/2038
231 12/10/2038
232 01/10/2039
233 02/10/2039
234 03/10/2039
235 04/10/2039
236 05/10/2039
237 06/10/2039
238 07/10/2039
239 08/10/2039
240 09/10/2039
241 10/10/2039
242 11/10/2039
243 12/10/2039
244 01/10/2040
245 02/10/2040
246 03/10/2040
247 04/10/2040
248 05/10/2040
249 06/10/2040
250 07/10/2040
251 08/10/2040
252 09/10/2040
253 10/10/2040
254 11/10/2040
255 12/10/2040
256 01/10/2041
257 02/10/2041
258 03/10/2041
259 04/10/2041
260 05/10/2041
261 06/10/2041
262 07/10/2041
263 08/10/2041
264 09/10/2041
265 10/10/2041
266 11/10/2041
267 12/10/2041
268 01/10/2042
269 02/10/2042
270 03/10/2042
271 04/10/2042
272 05/10/2042
273 06/10/2042
274 07/10/2042
275 08/10/2042
276 09/10/2042
277 10/10/2042
278 11/10/2042
279 12/10/2042
280 01/10/2043
281 02/10/2043
282 03/10/2043
283 04/10/2043
284 05/10/2043
285 06/10/2043
286 07/10/2043
287 08/10/2043
288 09/10/2043
289 10/10/2043
290 11/10/2043
291 12/10/2043
292 01/10/2044
293 02/10/2044
294 03/10/2044
295 04/10/2044
296 05/10/2044
297 06/10/2044
298 07/10/2044
299 08/10/2044
300 09/10/2044
301 10/10/2044
302 11/10/2044
303 12/10/2044
304 01/10/2045
305 02/10/2045
306 03/10/2045
307 04/10/2045
308 05/10/2045
309 06/10/2045
310 07/10/2045
311 08/10/2045
312 09/10/2045
313 10/10/2045
314 11/10/2045
315 12/10/2045
316 01/10/2046
317 02/10/2046
318 03/10/2046
319 04/10/2046
320 05/10/2046
321 06/10/2046
322 07/10/2046
323 08/10/2046
324 09/10/2046
325 10/10/2046
326 11/10/2046
327 12/10/2046
328 01/10/2047
329 02/10/2047
330 03/10/2047
331 04/10/2047
332 05/10/2047
333 06/10/2047
334 07/10/2047
335 08/10/2047
336 09/10/2047
337 10/10/2047
338 11/10/2047
339 12/10/2047
340 01/10/2048
341 02/10/2048
342 03/10/2048
343 04/10/2048
344 05/10/2048
345 06/10/2048
346 07/10/2048
347 08/10/2048
348 09/10/2048
349 10/10/2048
350 11/10/2048
351 12/10/2048
352 01/10/2049
353 02/10/2049
354 03/10/2049
355 04/10/2049
356 05/10/2049
357 06/10/2049
358 07/10/2049
359 08/10/2049
360 09/10/2049
361 10/10/2049
362 11/10/2049
363 12/10/2049
364 01/10/2050
365 02/10/2050
366 03/10/2050
367 04/10/2050
368 05/10/2050
369 06/10/2050
370 07/10/2050
371 08/10/2050
372 09/10/2050
373 10/10/2050
374 11/10/2050
375 12/10/2050
376 01/10/2051
377 02/10/2051
378 03/10/2051
379 04/10/2051
380 05/10/2051
381 06/10/2051
382 07/10/2051
383 08/10/2051
384 09/10/2051
385 10/10/2051
386 11/10/2051
387 12/10/2051
388 01/10/2052
389 02/10/2052
390 03/10/2052
391 04/10/2052
392 05/10/2052
393 06/10/2052
394 07/10/2052
395 08/10/2052
396 09/10/2052
397 10/10/2052
398 11/10/2052
399 12/10/2052
400 01/10/2053
401 02/10/2053
402 03/10/2053
403 04/10/2053
404 05/10/2053
405 06/10/2053
406 07/10/2053
407 08/10/2053
408 09/10/2053
409 10/10/2053
410 11/10/2053
411 12/10/2053
412 01/10/2054
413 02/10/2054
414 03/10/2054
415 04/10/2054
416 05/10/2054
417 06/10/2054
418 07/10/2054
419 08/10/2054
420 09/10/2054
421 10/10/2054
422 11/10/2054
423 12/10/2054
424 01/10/2055
425 02/10/2055
426 03/10/2055
427 04/10/2055
428 05/10/2055
429 06/10/2055
430 07/10/2055
431 08/10/2055
432 09/10/2055
433 10/10/2055
434 11/10/2055
435 12/10/2055
436 01/10/2056
437 02/10/2056
438 03/10/2056
439 04/10/2056
440 05/10/2056
441 06/10/2056
442 07/10/2056
443 08/10/2056
444 09/10/2056
445 10/10/2056
446 11/10/2056
447 12/10/2056
448 01/10/2057
449 02/10/2057
450 03/10/2057
451 04/10/2057
452 05/10/2057
453 06/10/2057
454 07/10/2057
455 08/10/2057
456 09/10/2057
457 10/10/2057
458 11/10/2057
459 12/10/2057
460 01/10/2058
461 02/10/2058
462 03/10/2058
463 04/10/2058
464 05/10/2058
465 06/10/2058
466 07/10/2058
467 08/10/2058
468 09/10/2058
469 10/10/2058
470 11/10/2058
471 12/10/2058
472 01/10/2059
473 02/10/2059
474 03/10/2059
475 04/10/2059
476 05/10/2059
477 06/10/2059
478 07/10/2059
479 08/10/2059
480 09/10/2059
481 10/10/2059
482 11/10/2059
483 12/10/2059
484 01/10/2060
485 02/10/2060
486 03/10/2060
487 04/10/2060
488 05/10/2060
489 06/10/2060
490 07/10/2060
491 08/10/2060
492 09/10/2060
493 10/10/2060
494 11/10/2060
495 12/10/2060
496 01/10/2061
497 02/10/2061
498 03/10/2061
499 04/10/2061
500 05/10/2061
501 06/10/2061
502 07/10/2061
503 08/10/2061
504 09/10/2061
505 10/10/2061
506 11/10/2061
507 12/10/2061
508 01/10/2062
509 02/10/2062
510 03/10/2062
511 04/10/2062
512 05/10/2062
513 06/10/2062
514 07/10/2062
515 08/10/2062
516 09/10/2062
517 10/10/2062
518 11/10/2062
519 12/10/2062
520 01/10/2063
521 02/10/2063
522 03/10/2063
523 04/10/2063
524 05/10/2063
525 06/10/2063
526 07/10/2063
527 08/10/2063
528 09/10/2063
529 10/10/2063
530 11/10/2063
531 12/10/2063
532 01/10/2064
533 02/10/2064
534 03/10/2064
535 04/10/2064
536 05/10/2064
537 06/10/2064
538 07/10/2064
539 08/10/2064
540 09/10/2064
541 10/10/2064
542 11/10/2064
543 12/10/2064
544 01/10/2065
545 02/10/2065
546 03/10/2065
547 04/10/2065
548 05/10/2065
549 06/10/2065
550 07/10/2065
551 08/10/2065
552 09/10/2065
553 10/10/2065
554 11/10/2065
555 12/10/2065
556 01/10/2066
557 02/10/2066
558 03/10/2066
559 04/10/2066
560 05/10/2066
561 06/10/2066
562 07/10/2066
563 08/10/2066
564 09/10/2066
565 10/10/2066
566 11/10/2066
567 12/10/2066
568 01/10/2067
569 02/10/2067
570 03/10/2067
571 04/10/2067
572 05/10/2067
573 06/10/2067
574 07/10/2067
575 08/10/2067
576 09/10/2067
577 10/10/2067
578 11/10/2067
579 12/10/2067
580 01/10/2068
581 02/10/2068
582 03/10/2068
583 04/10/2068
584 05/10/2068
585 06/10/2068
586 07/10/2068
587 08/10/2068
588 09/10/2068
589 10/10/2068
590 11/10/2068
591 12/10/2068
592 01/10/2069
593 02/10/2069
594 03/10/2069
595 04/10/2069
596 05/10/2069
597 06/10/2069
598 07/10/2069
599 08/10/2069
600 09/10/2069
601 10/10/2069
602 11/10/2069
603 12/10/2069
604 01/10/2070
605 02/10/2070
606 03/10/2070
607 04/10/2070
608 05/10/2070
609 06/10/2070
610 07/10/2070
611 08/10/2070
612 09/10/2070
613 10/10/2070
614 11/10/2070
615 12/10/2070
616 01/10/2071
617 02/10/2071
618 03/10/2071
619 04/10/2071
620 05/10/2071
621 06/10/2071
622 07/10/2071
623 08/10/2071
624 09/10/2071
625 10/10/2071
626 11/10/2071
627 12/10/2071
628 01/10/2072
629 02/10/2072
630 03/10/2072
631 04/10/2072
632 05/10/2072
633 06/10/2072
634 07/10/2072
635 08/10/2072
636 09/10/2072
637 10/10/2072
638 11/10/2072
639 12/10/2072
640 01/10/2073
641 02/10/2073
642 03/10/2073
643 04/10/2073
644 05/10/2073
645 06/10/2073
646 07/10/2073
647 08/10/2073
648 09/10/2073
649 10/10/2073
650 11/10/2073
651 12/10/2073
652 01/10/2074
653 02/10/2074
654 03/10/2074
655 04/10/2074
656 05/10/2074
657 06/10/2074
658 07/10/2074
659 08/10/2074
660 09/10/2074
661 10/10/2074
662 11/10/2074
663 12/10/2074
664 01/10/2075
665 02/10/2075
666 03/10/2075
667 04/10/2075
668 05/10/2075
669 06/10/2075
670 07/10/2075
671 08/10/2075
672 09/10/2075
673 10/10/2075
674 11/10/2075
675 12/10/2075
676 01/10/2076
677 02/10/2076
678 03/10/2076
679 04/10/2076
680 05/10/2076
681 06/10/2076
682 07/10/2076
683 08/10/2076
684 09/10/2076
685 10/10/2076
686 11/10/2076
687 12/10/2076
688 01/10/2077
689 02/10/2077
690 03/10/2077
691 04/10/2077
692 05/10/2077
693 06/10/2077
694 07/10/2077
695 08/10/2077
696 09/10/2077
697 10/10/2077
698 11/10/2077
699 12/10/2077
700 01/10/2078
701 02/10/2078
702 03/10/2078
703 04/10/2078
704 05/10/2078
705 06/10/2078
706 07/10/2078
707 08/10/2078
708 09/10/2078
709 10/10/2078
710 11/10/2078
711 12/10/2078
712 01/10/2079
713 02/10/2079
714 03/10/2079
715 04/10/2079
716 05/10/2079
717 06/10/2079
718 07/10/2079
719 08/10/2079
720 09/10/2079
721 10/10/2079
722 11/10/2079
723 12/10/2079
724 01/10/2080
725 02/10/2080
726 03/10/2080
727 04/10/2080
728 05/10/2080
729 06/10/2080
730 07/10/2080
731 08/10/2080
732 09/10/2080
733 10/10/2080
734 11/10/2080
735 12/10/2080
736 01/10/2081
737 02/10/2081
738 03/10/2081
739 04/10/2081
740 05/10/2081
741 06/10/2081
742 07/10/2081
743 08/10/2081
744 09/10/2081
745 10/10/2081
746 11/10/2081
747 12/10/2081
748 01/10/2082
749 02/10/2082
750 03/10/2082
751 04/10/2082
752 05/10/2082
753 06/10/2082
754 07/10/2082
755 08/10/2082
756 09/10/2082
757 10/10/2082
758 11/10/2082
759 12/10/2082
760 01/10/2083
76

NO.	DESCRIPTION
1	REMOVE EXISTING WALL OPENING WITH CONSTRUCTION TO MATCH EXISTING (NEW) NEW SURFACE FINISH WITH EXISTING ADJACENT SURFACES
2	NEW CONCRETE AT OWNER
3	NEW CONCRETE FLOOR TO MATCH EXISTING
4	WALL HEIGHT 8'-0" SHALL HOSE CHAMION TOP OF WALL

GENERAL PLAN NOTES	
1.	ALL CONSTRUCTION SHALL BE IN ACCORDANCE WITH THE 2015 INTERNATIONAL RESIDENTIAL CODE BOOK (IRC) AND THE 2015 INTERNATIONAL BUILDING CODE (IBC) UNLESS OTHERWISE NOTED.
2.	CONCRETE SHALL BE 3000 PSI MINIMUM COMPRESSIVE STRENGTH WITH 4% MINIMUM STEEL REINFORCEMENT UNLESS OTHERWISE NOTED.
3.	ALL WALL CONSTRUCTION SHALL BE 8" MINIMUM THICKNESS UNLESS OTHERWISE NOTED.
4.	ALL FLOOR FINISHES SHALL BE 1/2" MINIMUM THICKNESS UNLESS OTHERWISE NOTED.
5.	ALL CEILING FINISHES SHALL BE 1/2" MINIMUM THICKNESS UNLESS OTHERWISE NOTED.
6.	ALL ROOF FINISHES SHALL BE 1/2" MINIMUM THICKNESS UNLESS OTHERWISE NOTED.
7.	ALL MECHANICAL SYSTEMS SHALL BE INSTALLED IN ACCORDANCE WITH THE 2015 INTERNATIONAL MECHANICAL CODE (IMC).
8.	ALL ELECTRICAL SYSTEMS SHALL BE INSTALLED IN ACCORDANCE WITH THE 2015 NATIONAL ELECTRICAL CODE (NEC).
9.	ALL PLUMBING SYSTEMS SHALL BE INSTALLED IN ACCORDANCE WITH THE 2015 INTERNATIONAL PLUMBING CODE (IPC).
10.	ALL FIRE PROTECTION SYSTEMS SHALL BE INSTALLED IN ACCORDANCE WITH THE 2015 INTERNATIONAL FIRE CODE (IFC).

GENERAL DEMO PLAN NOTES	
1.	REMOVE EXISTING WALL OPENING WITH CONSTRUCTION TO MATCH EXISTING (NEW) NEW SURFACE FINISH WITH EXISTING ADJACENT SURFACES
2.	REMOVE EXISTING WALL AND PREP ADJACENT SURFACES AS REQUIRED FOR NEW CONSTRUCTION
3.	REMOVE EXISTING CEILING ASSEMBLY & LIGHT FIXTURES
4.	REMOVE EXISTING FLOOR FINISH & BASE TO ACCOMMODATE NEW CONSTRUCTION. COORDINATE WITH PLUMBING
5.	REMOVE EXISTING TOILET TO ACCOMMODATE NEW CONSTRUCTION
6.	REMOVE EXISTING TOILET PARTITION, GRAB BARS AND ACCESSORIES IN EXISTING TOILET ROOM

DEMOLITION PLAN KEYNOTES	
1.	REMOVE EXISTING DOOR & FRAME (JEFF) CONSTRUCTION SERVICES FOR NEW CONSTRUCTION SURFACES AS REQUIRED FOR NEW CONSTRUCTION
2.	REMOVE EXISTING GYPSUM PATCH TO MATCH EXISTING
3.	REMOVE EXISTING WALL AND PREP ADJACENT SURFACES AS REQUIRED FOR NEW CONSTRUCTION
4.	CUT OPENING IN EXISTING WALL FOR NEW CONSTRUCTION. PREP ADJACENT SURFACES AS REQUIRED FOR NEW CONSTRUCTION
5.	REMOVE CABINET HEATER
6.	REMOVE EXISTING PLUMBING RECYCLE. PREPARE FOR NEW CONSTRUCTION
7.	REMOVE EXISTING CEILING ASSEMBLY & LIGHT FIXTURES
8.	REMOVE FLOOR FINISH & BASE TO ACCOMMODATE NEW CONSTRUCTION. COORDINATE WITH PLUMBING
9.	REMOVE EXISTING TOILET TO ACCOMMODATE NEW CONSTRUCTION
10.	REMOVE TOILET PARTITION, GRAB BARS AND ACCESSORIES IN EXISTING TOILET ROOM

NOTE:
SEE PLUMBING, HVAC AND ELECTRICAL PLANS FOR ADDITIONAL INFORMATION

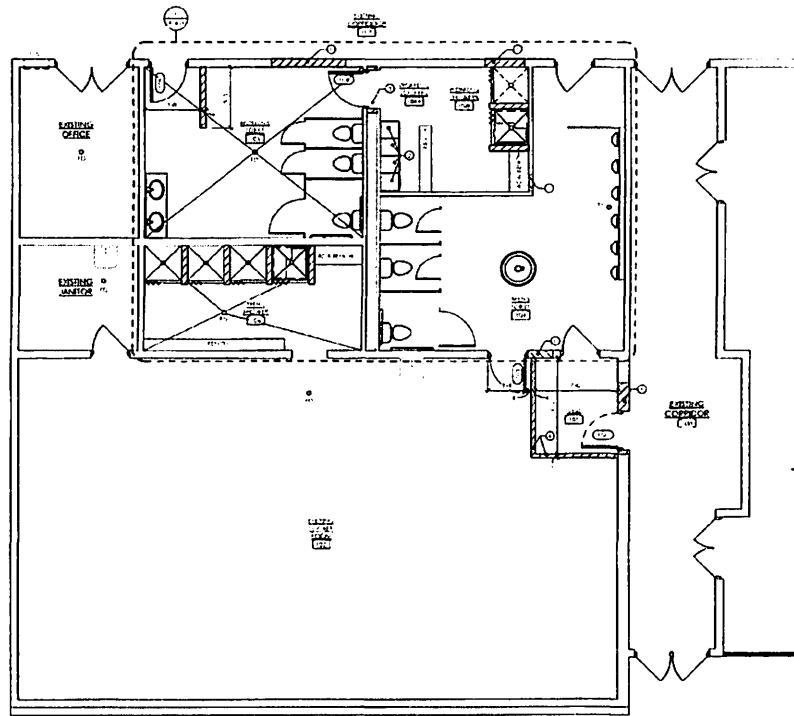

PARTIAL FIRST FLOOR PLAN
SCALE: 1/4" = 1'-0"
N
W
E
S

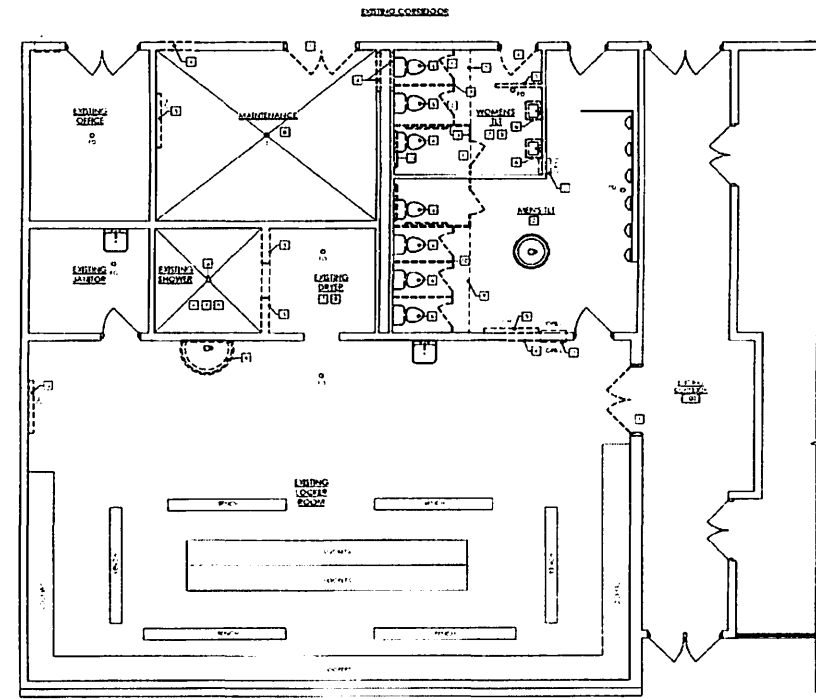

PARTIAL FIRST FLOOR-DEMOLITION PLAN
SCALE: 1/4" = 1'-0"
N
W
E
S



REVISIONS:

DATE: 01/15/2019
BY: [Signature]

PROJECT: LOCKER ROOM RENOVATIONS
 CITY OF SHEBOYGAN DPW RENOVATION
 2025 NEW JEFFREY AVE. SHEBOYGAN, WI 53081
 1124 WASHINGTON AVE. SHEBOYGAN, WI 53081 | PHONE: 920.224.4444 | FAX: 920.224.4440

DRAWN BY: GJP
 CHECKED BY: PJD
A
301
 PROJ. NO. 2019-22

BID SET

ROOM FINISH SCHEDULE											
NO	ROOM NAME	FLOOR	BASE	WALL FINISH / MATERIAL			CEILING	CEILING HEIGHT	FERROUS METALS	WOOD	REMARKS
				NORTH	EAST	WEST					
100	EXISTING CORRIDOR	F01	EXST	-	EXST	EXST	EXST	-	-	-	-
101	VEST	EXST	EXST	P-3	P-3	P-3	ACT	1-4	P-1	-	1-2
102	EXISTING LOCKER ROOM	EXST	EXST	P-3	P-3	P-3	EXST	1-4	P-1	-	1
103	MEN'S TOILET	F01	EXST	P-3	P-3	SGT	ACT	1-2	P-1	-	1
104A	WOMEN'S LOCKERS	PG	FTB	P-3	P-3	P-3	ACT	1-2	P-1	-	1
104B	WOMEN'S SHOWERS	PG	FTB	P-3	P-3	P-3	ACT	1-2	P-1	-	1
105	WOMEN'S TOILET	PG	FTB	P-3	P-3	P-3	ACT	1-2	P-1	-	1
106	MEN'S SHOWER	PG	FTB	P-3	P-3	P-3	ACT	1-2	P-1	-	1
107	EXISTING CORRIDOR	-	-	-	-	P-3	-	-	-	-	-

DOOR SCHEDULE												
DOOR NO	DOOR SIZE	ELEV	MATEL	GLASS TYPE	HARDWARE SET NO	FRAME			RFD RATING	REMARKS		
						ELEV	MATEL	DEPTH				
101	1'-0" x 7'-0"	D-1	NMA	-	BY OWNER	F-1	NMA	5/32"	2/A302	2/A302	-	-
102	1'-0" x 7'-0"	D-1	NMA	-	BY OWNER	F-1	NMA	5/32"	2/A302	2/A302	-	-
104	1'-0" x 7'-0"	D-1	NMA	-	BY OWNER	F-1	NMA	5/32"	2/A302	2/A302	-	-
105	1'-0" x 7'-0"	D-1	NMA	-	BY OWNER	F-1	NMA	5/32"	2/A302	2/A302	-	-

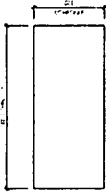

D-1
DOOR TYPES
SCALE 1/12" = 1'-0"

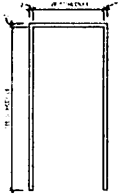

F-1
FRAME TYPE
SCALE 1/12" = 1'-0"

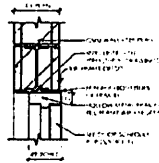

HEAD/JAMB DETAIL (2)
SCALE 1/12" = 1'-0" (A.30)

ROOM FINISH REMARKS	
NO	DESCRIPTION
1	PATCH AND REPAIR EXISTING FLOOR AND BASE TO MATCH EXISTING AT AREAS OF CONSTRUCTION
2	FRAME DOOR AND DOOR FRAME P-1

ROOM FINISH LEGEND	
KEY	DESCRIPTION
ACT-1	ACQUITY CEILING TILE - 24" x 24"
ACT-2	VPF FACED GYPSUM BOARD - 24" x 24" x 5/8"
CMU	CONCRETE MASONRY UNIT
CCFC	CONCRETE
CRF	CHALK
IS	EXPOSED STRUCTURE
BY	BRUSHED FINISH
GYP	GYPSUM BOARD
HSL	MELLOW METAL
P	PART FINISH
FG	FURFUR QUARTZ
PT	POCELLAN TILE
PTA	POCELLAN TILE BASE
CC	HEART CONCRETE
SPF	STRUCTURAL GLAZED FACING IRL
YS	YORK BASE
VCL	VITROL COMPOSITION TILE
WD	WOOD

REFLECTED CEILING PLAN LEGEND	
[Grid Pattern]	ACQUITY CEILING TILE
[Hatched Pattern]	POCELLAN TILE
[Solid Black]	WOOD



REVISIONS:

DATE: 01/11/2019
BY: [Signature]
DESCRIPTION: [Text]

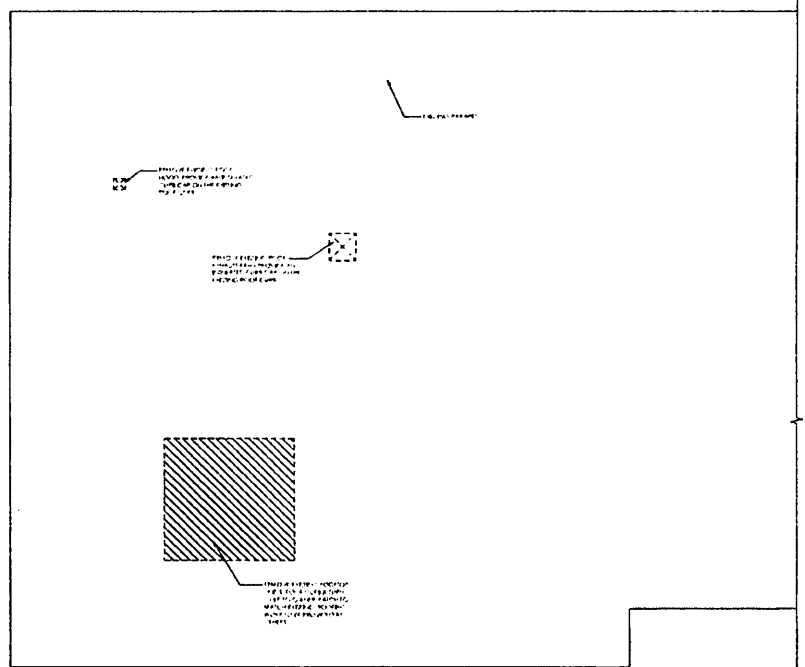

PARTIAL DEMOLITION ROOF PLAN
SCALE 1/4" = 1'-0" (A.30)

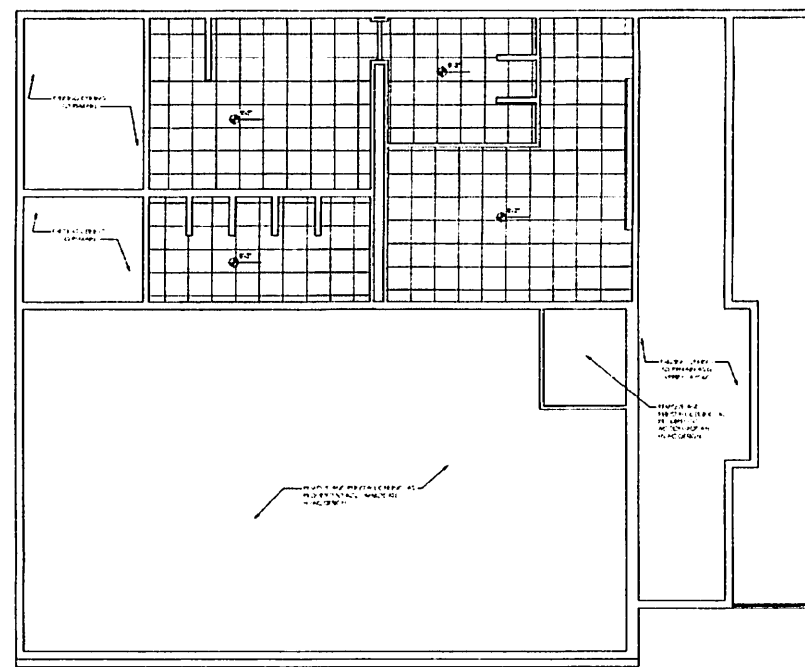

PARTIAL REFLECTED CEILING PLAN
SCALE 1/4" = 1'-0" (A.30)

CITY OF SHEBOYGAN DPW RENOVATION
 2026 NEW JERSEY AVE. SHEBOYGAN, WI 53081
 1134 MONROE AVE. SHEBOYGAN, WI 53081 | (920) 852-4444 | 225 EAST ST. FAIR AVE. MILWAUKEE, WI 53202 (414) 857-4450

DRAWN BY: GFE
CHECKED BY: RED

A
302
PROJ. NO. 2019-22

BID SET

REVISIONS:



FACTORY-BUILT RESTROOM
FACTORY-BUILT RESTROOM

LOCKER ROOM RENOVATIONS
CITY OF SHEBOYGAN DPW RENOVATION
3026 NEW JERSEY AVE. SHEBOYGAN, WI 53081
1135A WASHINGTON AVE. SHEBOYGAN, WI 53081 | TEL: 920.834.1100 | FAX: 920.834.1100

LOCKER ROOM RENOVATIONS
CITY OF SHEBOYGAN DPW RENOVATION
3026 NEW JERSEY AVE. SHEBOYGAN, WI 53081
1135A WASHINGTON AVE. SHEBOYGAN, WI 53081 | TEL: 920.834.1100 | FAX: 920.834.1100

DESIGNED BY: GCP
CHECKED BY: KED
A
303
PROJ. NO. 2019-22

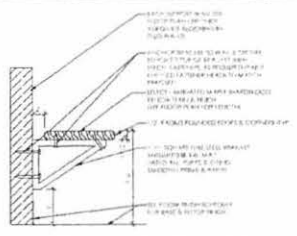

CONT. WALL BENCH DETAIL
SCALE: 1/2" = 1'-0" (A 303)

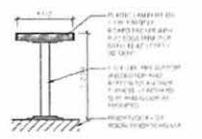

BENCH DETAIL
SCALE: 1/2" = 1'-0" (A 303)

ACCESSIBLE TOILET ROOM ACCESSORIES DETAIL
SCALE: 1/2" = 1'-0" (A 303)

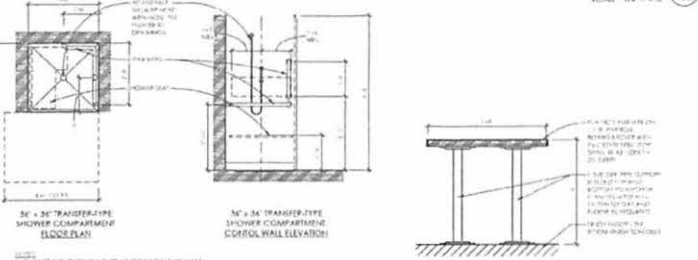

ACCESSIBLE TRANSFER SHOWER DETAIL
SCALE: 1/2" = 1'-0" (A 303)

ACCESSIBLE BENCH DETAIL
SCALE: 1/2" = 1'-0" (A 303)

ACCESSIBLE SIGNAGE DETAIL
SCALE: 3" = 1'-0" (A 303)

TOILET ROOM KEYNOTES

NO.	DESCRIPTION
1	1/2" GRAB BAR
2	3/4" GRAB BAR
3	1" GRAB BAR
4	IMPACT - SEE ELEVATION FOR SIZE
5	TYPICAL SHOWER STALL - SEE FINISH SCHEDULE
6	FOLDING SHOWER SEAT - WALL MOUNTED AT 18" AFF
7	SHOWER CURTAIN AND CURTAIN ROD - MOUNTED HORIZ
8	ROCK HOOD - SEE DETAIL 10(A.303) FOR MOUNTING HEIGHT

GENERAL PLAN NOTES

- ALL TOILET ROOMS SHALL BE ACCESSIBLE TO ALL PEOPLE WITH PHYSICAL DISABILITIES. ALL TOILET ROOMS SHALL BE ACCESSIBLE TO ALL PEOPLE WITH PHYSICAL DISABILITIES. ALL TOILET ROOMS SHALL BE ACCESSIBLE TO ALL PEOPLE WITH PHYSICAL DISABILITIES.
- GENERAL CONTRACTOR SHALL PROVIDE THE NECESSARY DIMENSIONS.
- GENERAL CONTRACTOR SHALL PROVIDE THE NECESSARY DIMENSIONS.
- GENERAL CONTRACTOR SHALL PROVIDE THE NECESSARY DIMENSIONS.
- GENERAL CONTRACTOR SHALL PROVIDE THE NECESSARY DIMENSIONS.
- GENERAL CONTRACTOR SHALL PROVIDE THE NECESSARY DIMENSIONS.

TOILET ROOM ELEVATION
SCALE: 1/2" = 1'-0" (A 303)

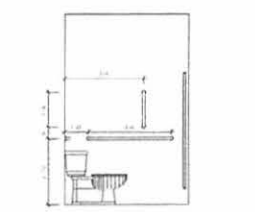

TOILET ROOM ELEVATION
SCALE: 1/2" = 1'-0" (A 303)

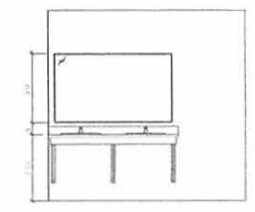

TOILET ROOM ELEVATION
SCALE: 1/2" = 1'-0" (A 303)

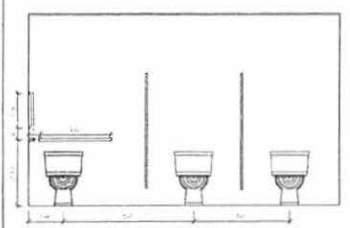

TOILET ROOM ELEVATION
SCALE: 1/2" = 1'-0" (A 303)

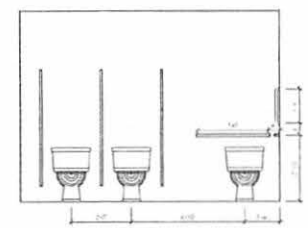

TOILET ROOM ELEVATION
SCALE: 1/2" = 1'-0" (A 303)

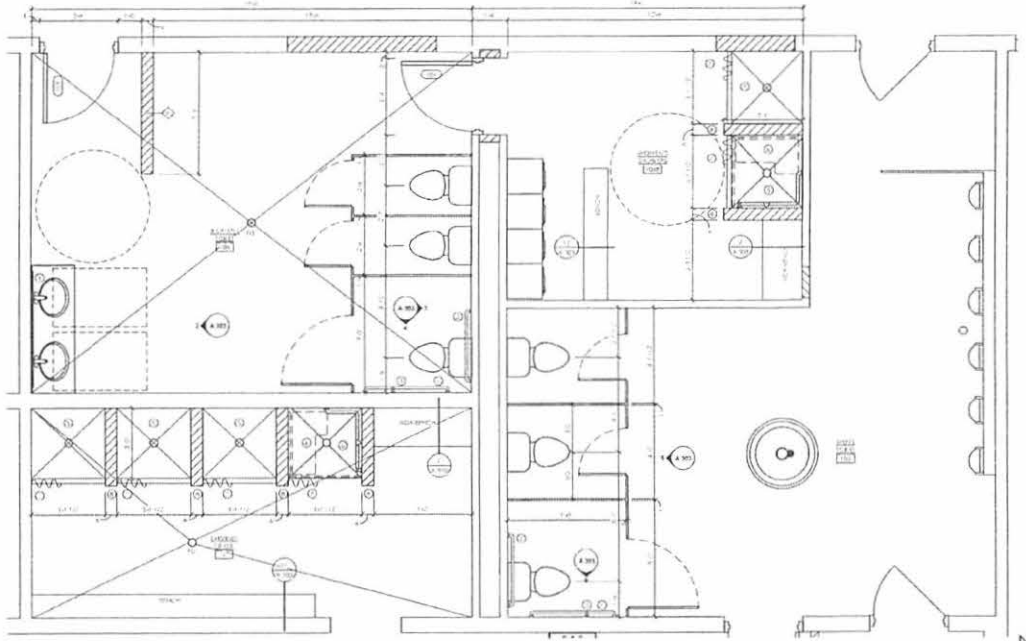

ENLARGED TOILET/LOCKER/SHOWER ROOM
SCALE: 1/2" = 1'-0" (A 303)



BID SET

FIRE PROTECTION NOTES

1. ALL NEW AND EXISTING ROOMS SHALL BE PROVIDED WITH AUTOMATICALLY ACTIVATING FIRE ALARMS (AFA) AND SMOKE DETECTORS (SD) AS SHOWN ON THIS PLAN. THE AFA SHALL BE INSTALLED IN ACCORDANCE WITH NFPA 72, SECTION 7.5.1. THE SD SHALL BE INSTALLED IN ACCORDANCE WITH NFPA 72, SECTION 7.6.1. THE AFA AND SD SHALL BE WIRING TO A CENTRAL STATION OR MONITORING STATION AS SHOWN ON THIS PLAN.

2. ALL NEW AND EXISTING ROOMS SHALL BE PROVIDED WITH PORTABLE FIRE EXTINGUISHERS (PFE) AS SHOWN ON THIS PLAN. THE PFE SHALL BE INSTALLED IN ACCORDANCE WITH NFPA 10, SECTION 4.1.1. THE PFE SHALL BE WIRING TO A CENTRAL STATION OR MONITORING STATION AS SHOWN ON THIS PLAN.

3. ALL NEW AND EXISTING ROOMS SHALL BE PROVIDED WITH FIRE EXTINGUISHERS (FE) AS SHOWN ON THIS PLAN. THE FE SHALL BE INSTALLED IN ACCORDANCE WITH NFPA 10, SECTION 4.1.1. THE FE SHALL BE WIRING TO A CENTRAL STATION OR MONITORING STATION AS SHOWN ON THIS PLAN.

4. ALL NEW AND EXISTING ROOMS SHALL BE PROVIDED WITH FIRE EXTINGUISHERS (FE) AS SHOWN ON THIS PLAN. THE FE SHALL BE INSTALLED IN ACCORDANCE WITH NFPA 10, SECTION 4.1.1. THE FE SHALL BE WIRING TO A CENTRAL STATION OR MONITORING STATION AS SHOWN ON THIS PLAN.

5. ALL NEW AND EXISTING ROOMS SHALL BE PROVIDED WITH FIRE EXTINGUISHERS (FE) AS SHOWN ON THIS PLAN. THE FE SHALL BE INSTALLED IN ACCORDANCE WITH NFPA 10, SECTION 4.1.1. THE FE SHALL BE WIRING TO A CENTRAL STATION OR MONITORING STATION AS SHOWN ON THIS PLAN.

FIRE PROTECTION SYSTEM LEGEND

□ AUTOMATICALLY ACTIVATING FIRE ALARMS (AFA)

□ SMOKE DETECTORS (SD)

□ PORTABLE FIRE EXTINGUISHERS (PFE)

□ FIRE EXTINGUISHERS (FE)

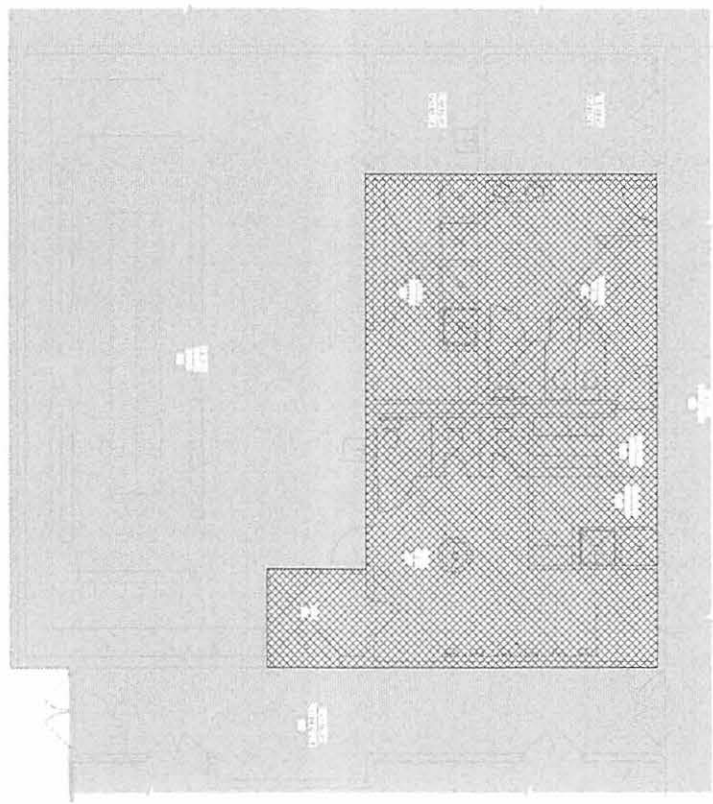

PARTIAL FIRST FLOOR PLAN - FIRE PROTECTION
SCALE: 1/8" = 1'-0"



REVISIONS:

SEPTEMBER 6, 2019
LOCKER ROOM RENOVATION
SHEBOYGAN DPW RENOVATION
2026 NEW JERSEY AVE, SHEBOYGAN, WI 53081
1135A MICHIGAN AVE. SHEBOYGAN, WI 53081 | (920) 453-4444 | 205 EAST ST. PALM AVE. MILWAUKEE, WI 53202 | (414) 837-4450

DRAWN BY: TGO
CHECKED BY: JBT

FP
101

PROJ. NO. 2019-22



REVISIONS:

- 1. REVISED TO REFLECT CHANGES TO THE PROJECT.
- 2. REVISED TO REFLECT CHANGES TO THE PROJECT.
- 3. REVISED TO REFLECT CHANGES TO THE PROJECT.
- 4. REVISED TO REFLECT CHANGES TO THE PROJECT.

EXISTING P-OBJECT CONDITIONS NOTE

EXISTING CONDITIONS TO BE DEMOLISHED OR REMOVED SHALL BE SHOWN WITH DASHED LINES AND CIRCLED NUMBERS. ALL DEMOLITION SHALL BE IN ACCORDANCE WITH THE CITY OF NEW JERSEY PLUMBING CODE AND ALL APPLICABLE REGULATIONS. THE CONTRACTOR SHALL BE RESPONSIBLE FOR OBTAINING ALL NECESSARY PERMITS AND APPROVALS FROM THE APPROPRIATE AGENCIES.

GENERAL NOTES

1. ALL WORK SHALL BE IN ACCORDANCE WITH THE CITY OF NEW JERSEY PLUMBING CODE AND ALL APPLICABLE REGULATIONS.
2. THE CONTRACTOR SHALL BE RESPONSIBLE FOR OBTAINING ALL NECESSARY PERMITS AND APPROVALS FROM THE APPROPRIATE AGENCIES.
3. ALL DEMOLITION SHALL BE IN ACCORDANCE WITH THE CITY OF NEW JERSEY PLUMBING CODE AND ALL APPLICABLE REGULATIONS.
4. THE CONTRACTOR SHALL BE RESPONSIBLE FOR OBTAINING ALL NECESSARY PERMITS AND APPROVALS FROM THE APPROPRIATE AGENCIES.

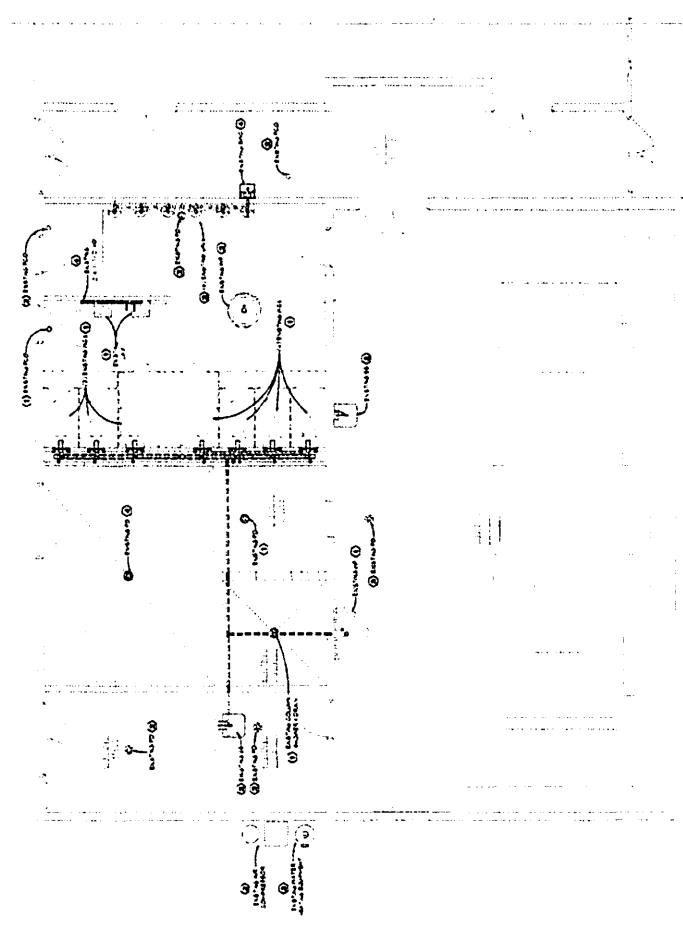

PARTIAL FIRST FLOOR DEMOLITION PLAN - PLUMBING
 SCALE: 1/8" = 1'-0"

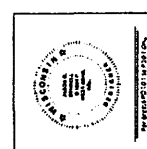

PLUMBING SHEET INDEX	
SHEET	DESCRIPTION
PD 101	PARTIAL FLOOR PLAN
PD 102	PARTIAL DEMOLITION PLAN
PD 103	PARTIAL PLUMBING & SANITARIAS
PD 104	MECHANICAL & ELECTRICAL

LOCKER ROOM RENOVATION
 SHEBOGAN DPM RENOVATION
 2026 NEW JERSEY AVE. SHEBOGAN, WI 53081
 1134 HENRIETTA AVE. SHEBOGAN, WI 53081 | 231.845.4444 | 231.845.4444 | 1134 HENRIETTA AVE. SHEBOGAN, WI 53081

DRAWN BY: LOD
 CHECKED BY: JPS

PD
 101

PROJ. NO. 2019-22

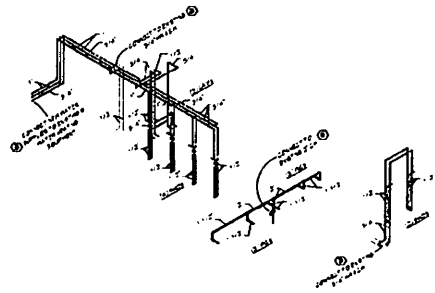

SUPPLY RISER DIAGRAM
SCALE: 1/4" = 1'-0" (P.10)

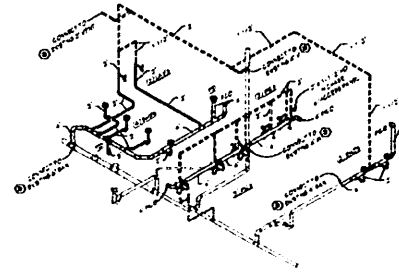

WASTE & VENT DIAGRAM
SCALE: 1/4" = 1'-0" (P.10)

IG
 In Motion - Custom Plumbing & Accessories, Inc.
 Plumbing & Fire Protection Installation

- KEY OF NOTES**
1. INDICATES EQUIPMENT TO BE REMOVED OR REPLACED BY THE CONTRACTOR. SEE SPECIFICATIONS FOR EQUIPMENT TO BE INSTALLED.
 2. INDICATES THE LOCATION OF THE EQUIPMENT TO BE INSTALLED.
 3. INDICATES THE LOCATION OF THE EQUIPMENT TO BE REMOVED OR REPLACED BY THE CONTRACTOR. SEE SPECIFICATIONS FOR EQUIPMENT TO BE INSTALLED.

ABACUS
 ARCHITECTS

REVISIONS:

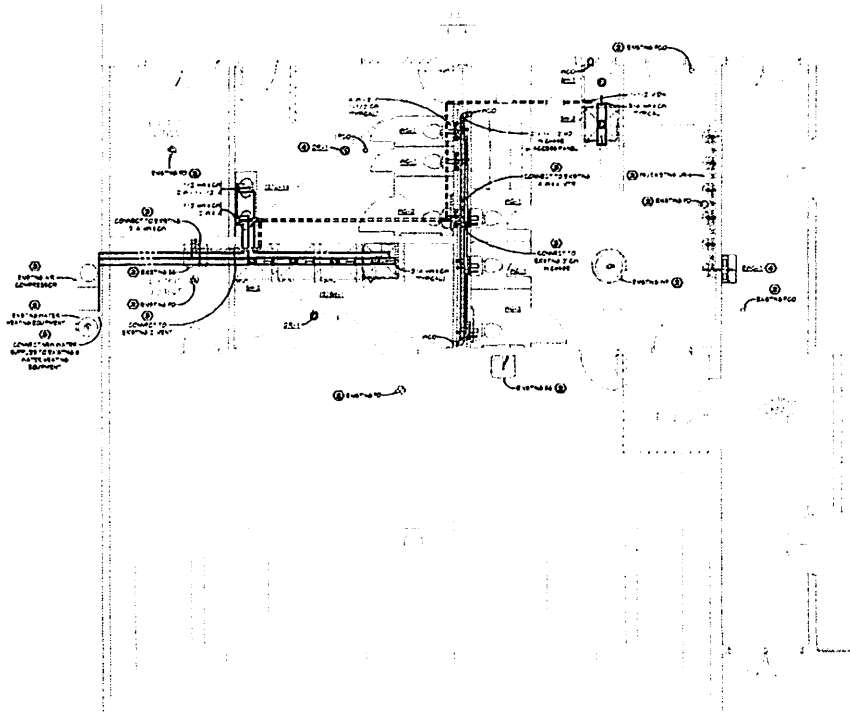

PARTIAL FIRST FLOOR PLAN - PLUMBING
SCALE: 1/4" = 1'-0" (P.10)

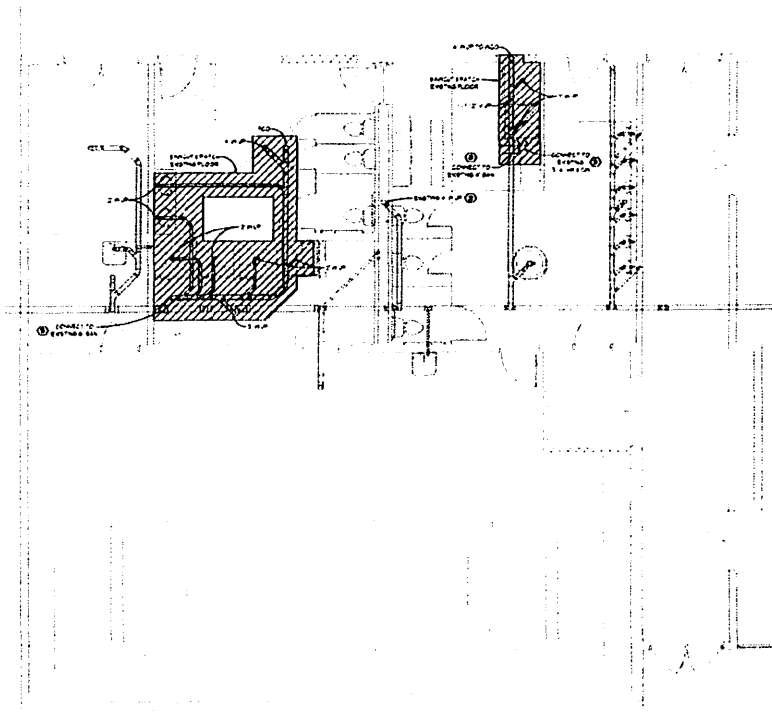

PARTIAL BELOW GRADE PLAN - PLUMBING
SCALE: 1/4" = 1'-0" (P.10)



DATE: 08/14/2019
 DRAWN BY: LGO
 CHECKED BY: #5

LOCKER ROOM RENOVATION
 SHEBOYGAN DPW RENOVATION
 2024 NEW JERSEY AVE. SHEBOYGAN, WI 53081
 11314 WISCONSIN AVE. SHEBOYGAN, WI 53081 TEL: 262.241.1111 FAX: 262.241.1112

DRAWN BY: LGO
 CHECKED BY: #5

P
 101

PROJ. NO. 2019-22

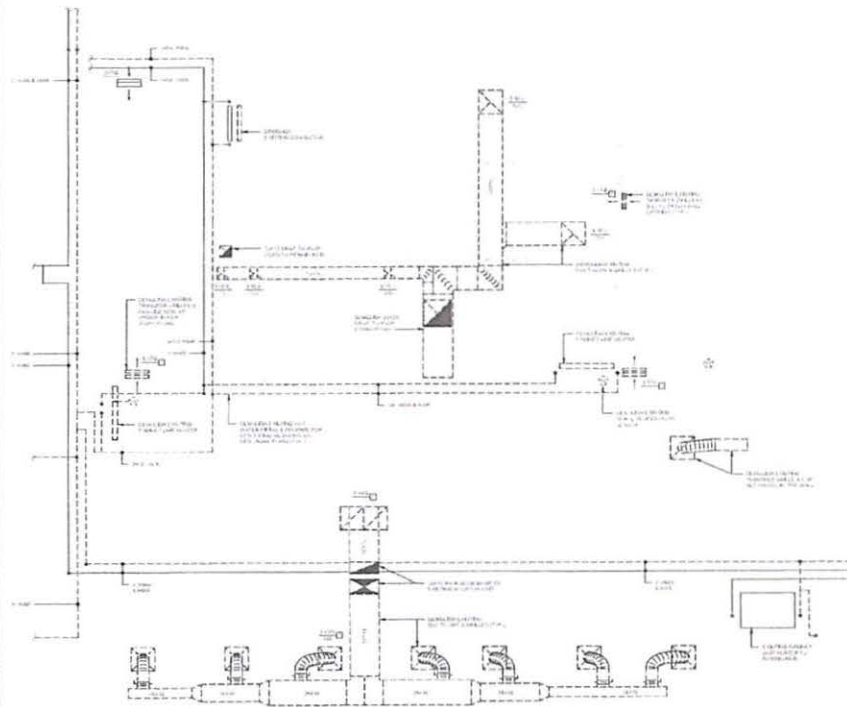

⊕ 2 FIRST FLOOR DEMOLITION PLAN

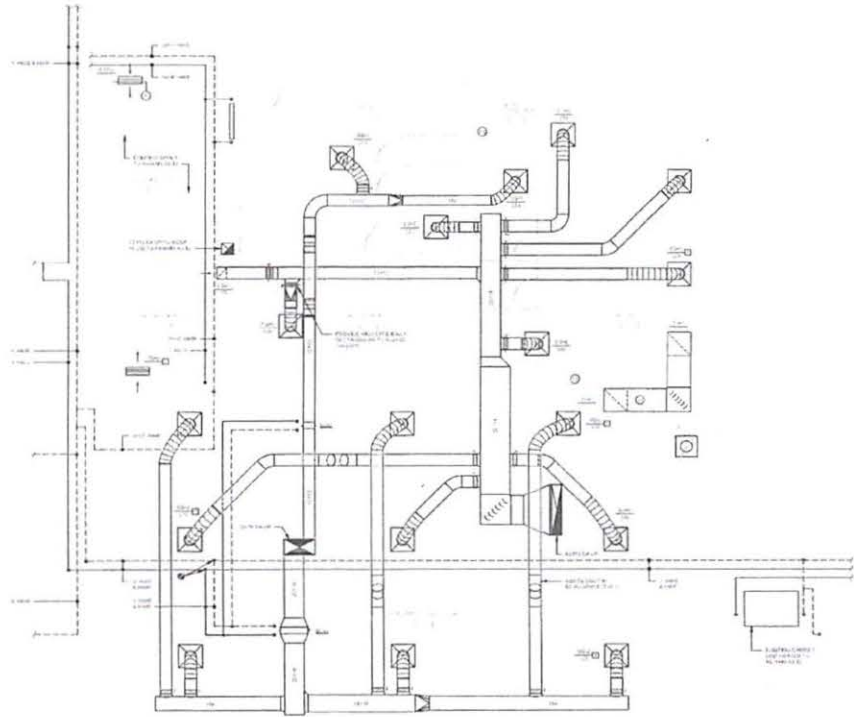

⊕ 1 FIRST FLOOR NEW WORK PLAN

4/15/2018
LOCKER ROOM RENOVATIONS
CITY OF SHEBOYGAN DPW RENOVATION

2026 NEW JERSEY AVE, SHEBOYGAN, WI 53081

1132A MICHIGAN AVE. SHEBOYGAN, WI 53081 | P: 224.412.4442 | 225 EAST ST. PAUL AVE. MILWAUKEE, WI 53202 | (414) 237-4452

⊕ 2 ROOF DEMOLITION PLAN

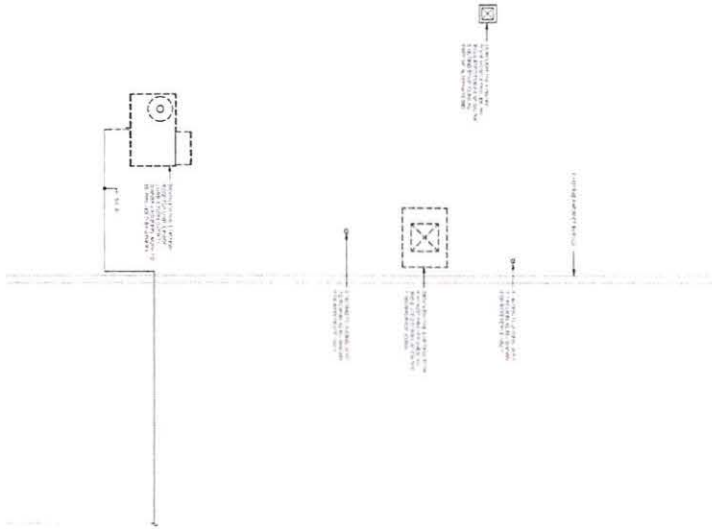

⊕ 1 ROOF NETWORK PLAN

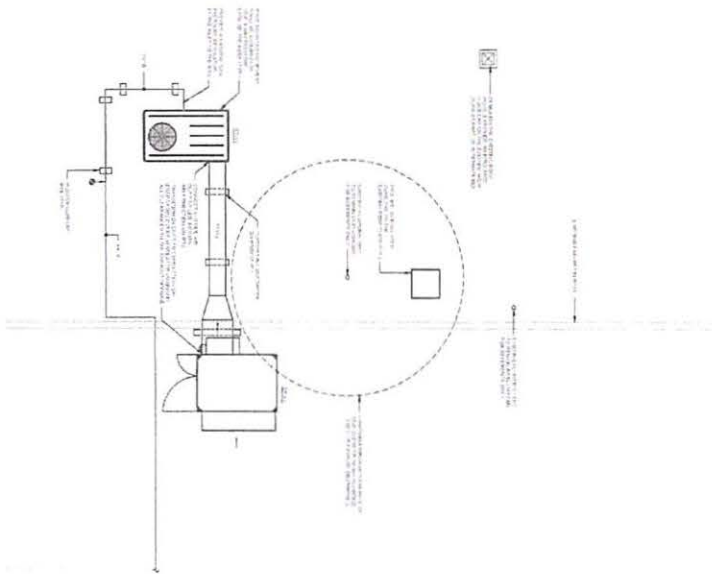

REVISIONS:

DATE: 01/20/2019
PROJECT: CITY OF SHEBOYGAN DPW RENOVATION
DRAWN BY: DCE
CHECKED BY: DCE

CITY OF SHEBOYGAN DPW RENOVATION
 2026 NEW JERSEY AVE. SHEBOYGAN, WI 53081
 1333A MCNEPP RD AVE. SHEBOYGAN, WI 53081 (P) 920.824.4444 | 225 EAST ST. AUBURN, WI 53001

DRAWN BY: DCE
 CHECKED BY: DCE
M
300
 DCE PROJECT: 1902
 PROJ. NO. 2019-22

MOTOR STARTER & ELECTRICAL CONNECTIONS															
TAG	EQUIPMENT TYPE	LOCATION	MOTOR DATA				MOTOR CONNECTIONS				MOTOR ELECTRICAL CONNECTIONS			NOTES	
			HP	VOLTS	PHASES	AMPS	WIRING METHOD	TERMINAL BLOCK	WIRING METHOD	TERMINAL BLOCK	WIRING METHOD	TERMINAL BLOCK			
1000	ROOFTOP UNIT	ROOFTOP	1/2	230	3	1.5	1	1	1	1	1	1	1	1	
1001	ENERGY RECOVERY VENTILATOR	ROOFTOP	1/2	230	3	1.5	1	1	1	1	1	1	1	1	

GRILLES, REGISTERS, & DIFFUSERS													
TAG	TYPE	LOCATION	SIZE	MANUFACTURER	MODEL	FINISH	INSTALLATION	NOTES					
1002	GRILLE	ROOFTOP	12" x 12"	GRILLE	GRILLE	GRILLE	GRILLE						
1003	REGISTER	ROOFTOP	12" x 12"	REGISTER	REGISTER	REGISTER	REGISTER						

EQUIPMENT SUPPORT COORDINATION										
TAG	EQUIPMENT TYPE	LOCATION	EQUIPMENT WEIGHT				EQUIPMENT SUPPORT			NOTES
			WGT	WGT	WGT	WGT	SUPPORT TYPE	WIRING METHOD	TERMINAL BLOCK	
1000	ROOFTOP UNIT	ROOFTOP	100	100	100	100	100	100	100	
1001	ENERGY RECOVERY VENTILATOR	ROOFTOP	100	100	100	100	100	100	100	

1. ALL WEIGHTS ARE BASED ON MANUFACTURER'S WEIGHTS. VERIFY WEIGHTS WITH MANUFACTURER.
 2. ALL WEIGHTS ARE BASED ON EQUIPMENT WEIGHTS. VERIFY WEIGHTS WITH MANUFACTURER.
 3. ALL WEIGHTS ARE BASED ON EQUIPMENT WEIGHTS. VERIFY WEIGHTS WITH MANUFACTURER.

ROOFTOP UNITS														
TAG	SERIES	UNIT DATA				UNIT CONNECTIONS				UNIT ELECTRICAL CONNECTIONS				NOTES
		WIRING METHOD	TERMINAL BLOCK	WIRING METHOD	TERMINAL BLOCK	WIRING METHOD	TERMINAL BLOCK	WIRING METHOD	TERMINAL BLOCK	WIRING METHOD	TERMINAL BLOCK	WIRING METHOD	TERMINAL BLOCK	
1000	ROOFTOP UNIT	1000	1000	1000	1000	1000	1000	1000	1000	1000	1000	1000	1000	
1001	ENERGY RECOVERY VENTILATOR	1001	1001	1001	1001	1001	1001	1001	1001	1001	1001	1001	1001	

1. ALL WEIGHTS ARE BASED ON MANUFACTURER'S WEIGHTS. VERIFY WEIGHTS WITH MANUFACTURER.
 2. ALL WEIGHTS ARE BASED ON EQUIPMENT WEIGHTS. VERIFY WEIGHTS WITH MANUFACTURER.
 3. ALL WEIGHTS ARE BASED ON EQUIPMENT WEIGHTS. VERIFY WEIGHTS WITH MANUFACTURER.

ENERGY RECOVERY VENTILATOR														
TAG	SERIES	UNIT DATA				UNIT CONNECTIONS				UNIT ELECTRICAL CONNECTIONS				NOTES
		WIRING METHOD	TERMINAL BLOCK	WIRING METHOD	TERMINAL BLOCK	WIRING METHOD	TERMINAL BLOCK	WIRING METHOD	TERMINAL BLOCK	WIRING METHOD	TERMINAL BLOCK	WIRING METHOD	TERMINAL BLOCK	
1001	ENERGY RECOVERY VENTILATOR	1001	1001	1001	1001	1001	1001	1001	1001	1001	1001	1001	1001	
1002	ENERGY RECOVERY VENTILATOR	1002	1002	1002	1002	1002	1002	1002	1002	1002	1002	1002	1002	

1. ALL WEIGHTS ARE BASED ON MANUFACTURER'S WEIGHTS. VERIFY WEIGHTS WITH MANUFACTURER.
 2. ALL WEIGHTS ARE BASED ON EQUIPMENT WEIGHTS. VERIFY WEIGHTS WITH MANUFACTURER.

BOOSTER COILS														
TAG	SERIES	UNIT DATA				UNIT CONNECTIONS				UNIT ELECTRICAL CONNECTIONS				NOTES
		WIRING METHOD	TERMINAL BLOCK	WIRING METHOD	TERMINAL BLOCK	WIRING METHOD	TERMINAL BLOCK	WIRING METHOD	TERMINAL BLOCK	WIRING METHOD	TERMINAL BLOCK	WIRING METHOD	TERMINAL BLOCK	
1003	BOOSTER COIL	1003	1003	1003	1003	1003	1003	1003	1003	1003	1003	1003	1003	
1004	BOOSTER COIL	1004	1004	1004	1004	1004	1004	1004	1004	1004	1004	1004	1004	

1. ALL WEIGHTS ARE BASED ON MANUFACTURER'S WEIGHTS. VERIFY WEIGHTS WITH MANUFACTURER.
 2. ALL WEIGHTS ARE BASED ON EQUIPMENT WEIGHTS. VERIFY WEIGHTS WITH MANUFACTURER.

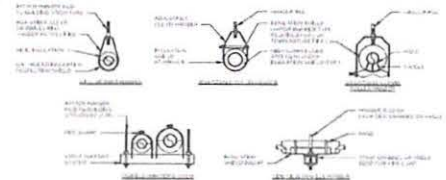

8 PIPE H-ANGERS & SUPPORTS DETAIL

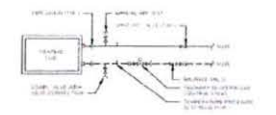

5 RUBBER SUPPORT RAIL DETAIL

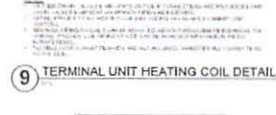

9 TERMINAL UNIT HEATING COIL DETAIL



10 ROOF MOUNTED ROOFTOP UNIT DETAIL

6 CONDENSATE DRAIN TRAP DETAIL

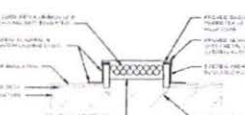

7 EXISTING ROOF CURB CAP DETAIL

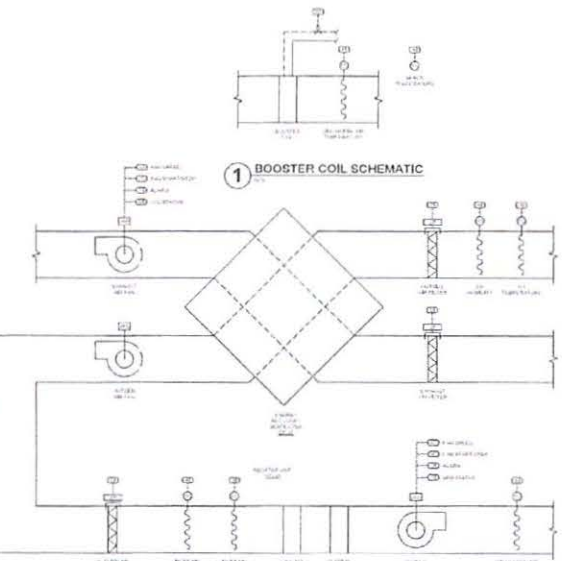

2 ROOFTOP UNIT & ENERGY RECOVERY VENTILATOR SCHEMATIC

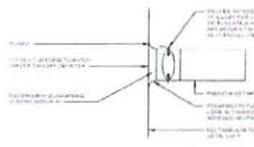

3 ROUND DUCT TAP CONNECTION DETAIL

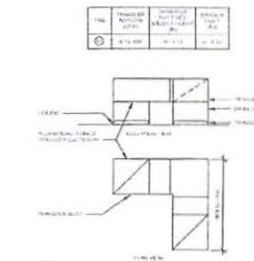

4 TRANSFER DUCT DETAIL



1 BOOSTER COIL SCHEMATIC

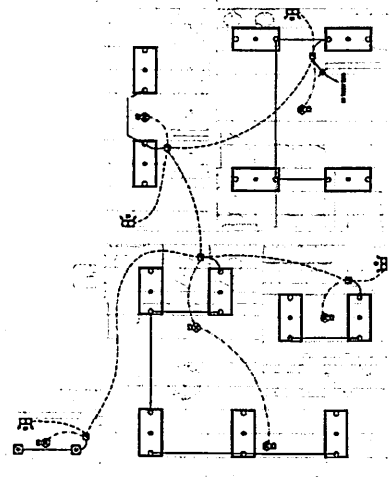

PARTIAL FIRST FLOOR LIGHTING PLAN

1. All symbols shown on drawings are to be installed as shown unless otherwise noted. 2. All symbols shown on drawings are to be installed as shown unless otherwise noted. 3. All symbols shown on drawings are to be installed as shown unless otherwise noted.

PARTIAL FIRST FLOOR POWER PLAN

FIXTURE SCHEDULE

NO.	TYPE	MANUFACTURER	MODEL	QUANTITY	REMARKS
1	RECESSED	OSRAM	4000K	10	10' x 18' RECESSED
2	RECESSED	OSRAM	4000K	10	10' x 18' RECESSED
3	RECESSED	OSRAM	4000K	10	10' x 18' RECESSED
4	RECESSED	OSRAM	4000K	10	10' x 18' RECESSED
5	RECESSED	OSRAM	4000K	10	10' x 18' RECESSED
6	RECESSED	OSRAM	4000K	10	10' x 18' RECESSED
7	RECESSED	OSRAM	4000K	10	10' x 18' RECESSED
8	RECESSED	OSRAM	4000K	10	10' x 18' RECESSED
9	RECESSED	OSRAM	4000K	10	10' x 18' RECESSED
10	RECESSED	OSRAM	4000K	10	10' x 18' RECESSED

MOTOR SCHEDULE

NO.	TYPE	MANUFACTURER	MODEL	QUANTITY	REMARKS
1	MOTOR	OSRAM	4000K	10	10' x 18' RECESSED
2	MOTOR	OSRAM	4000K	10	10' x 18' RECESSED
3	MOTOR	OSRAM	4000K	10	10' x 18' RECESSED
4	MOTOR	OSRAM	4000K	10	10' x 18' RECESSED
5	MOTOR	OSRAM	4000K	10	10' x 18' RECESSED
6	MOTOR	OSRAM	4000K	10	10' x 18' RECESSED
7	MOTOR	OSRAM	4000K	10	10' x 18' RECESSED
8	MOTOR	OSRAM	4000K	10	10' x 18' RECESSED
9	MOTOR	OSRAM	4000K	10	10' x 18' RECESSED
10	MOTOR	OSRAM	4000K	10	10' x 18' RECESSED

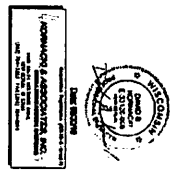

PROJECT NO. 19083
 DRAWING NO. 100
 CHECKED BY: D.S.

DATE: AUGUST 30, 2018
 LOCKER ROOM RENOVATION
SHEBOYGAN DPW RENOVATION
 2026 NEW JERSEY AVE. SHEBOYGAN, WI 53081
 1133A MICHIGAN AVE. SHEBOYGAN, WI 53081 (920) 457-4444 | 225 EAST ST. PALLA AVE. SHEBOYGAN, WI 53082 (414) 837-4450

ABACUS
 ARCHITECTS

REVISIONS:



RELATIONAL ARCHITECTURE

Addendum #1

Date: October 15th, 2019

City Of Sheboygan DPW Renovation

2026 New Jersey Ave
Sheboygan, WI 53081

Abacus Architects, Inc. Project No. 2019-22

This addendum is issued to explain, modify or correct the original Specifications and drawings and is hereby made a part of the contract Documents. This addendum must be attached to the specifications in your possession.

Pre-Bid Walkthrough

Add: Sign in sheet of bidders present at pre-bid walkthrough 10-11-19.

End of Addendum No. 1

CITY OF SHEBOYGAN
 REQUEST FOR BIDS #1974-19
 MUNICIPAL SERVICE BUILDING
 SHOWER AND BATH IMPROVEMENTS
 MANDATORY PRE-BID SIGN-IN SHEET
 OCTOBER 11, 2019 9:00 AM

COMPANY	NAME	PHONE	EMAIL
IMMEL	JOE GRANEY	920-406-0123	BIDS@IMMEL-BUILDERS.COM
Mike Koenig Const.	Richard Peterson	920-467-0923	richardp@mikekoenigconstruction.com
THE PIEPER ELECT	Tony Dohr	920-312-6156	Tony.DOHR@PIEPERPOWER.COM
A. Chappa Const.	Lance Hacker	920-467-2212	lance@achappaconstruction.com
ACE Building Service	Kyle Reuter	920-682-6105	Kreuter@acbuilding-service.com
Groeschel Co	Chris Aldag	920-979-8745	chrisa@groeschelco.com
Cardinal	Mike Duesterbach	920 922 4446	Mike@CardinalConstructionCo.com
Hackack Plumbing	Tony Weigert	920 892-6601	TonyWeigert@HackackPlumbing.com
J: H CONTRAS	TIM HACK	920-517-2125	THACK@JHCONTRAS.COM
Ben Steiner	Jos. Schmitt Const.	920 446 3925	Bstelmur@jschmitt.cc

CITY OF SHEBOYGAN
REQUEST FOR BIDS #1974-19
MUNICIPAL SERVICE BUILDING
SHOWER AND BATH IMPROVEMENTS
MANDATORY PRE-BID SIGN-IN SHEET
OCTOBER 11, 2019 9:00 AM

COMPANY	NAME	PHONE	EMAIL
JOS SCHMITZ	STEVE SCHMITZ	920 946-0991	sschmitt@joschmitz.com
SHOWCASE PAINTING	MICHAEL GABRIELSKI	(920) 207-6262	MGABRIELSKI@SHOWCASEPAINTING.COM
EDGEWATER PLUMBING	ADAM SCHMITZ	(920) 334-5535	adam@edgewaterplumbingllc.com
SCHAUS MECHANICAL	ROCK GOLLATA	920 684-5559	rigollata@schausme.com
J+H CONTROLS	MARK HAWLEY	920.322.8470	MHAWLEY@JHCONTROLS.COM
Aldag Harold Mech.	Tyler Abel	920-458-5558	tyler_a@aldagharold.com
ZEISE CONSTRUCTION	BOB GRETZINGER	920-437-5126	BOB@ZEISECONSTRUCTION.COM

**Addendum #2**

Date October 16, 2019

City Of Sheboygan DPW Renovation2026 New Jersey Ave
Sheboygan, WI 53081

Abacus Architects, Inc. Project No. 2019-22

This addendum is issued to explain, modify or correct the original Specifications and drawings and is hereby made a part of the contract Documents. This addendum must be attached to the specifications in your possession.

Bid Clarification**STRUCTURAL**

Clarify: New roof top unit support. See attached drawing.

HVAC

Q: Several of the supply and exhaust diffusers/grilles do not have designations or CFMs listed:

A: See the cover page for the symbols and abbreviation describing the typical notation for multiple grilles.

Q: Would it be possible to use the existing supply opening in the roof for the new supply drop?

A: This is acceptable as long as the unit is located at least 10'-0" away from the roof to avoid the need for guardrails at the edge of the roof.

Q: Control specifications are not included in the Construction Documents.

A: Controls specifications are provided on M000.

Q: Are controls through the Mechanical Contractor or is the Control Contractor bidding directly to the Owner. If controls are through the Mechanical Contractor, can you provide a specification with manufacturers and/or control contractors?

A: Controls specifications are provided on M000 and are part of the Mechanical Contractors scope of work. J&H Controls provides the controls work for the facility.

Q: Please provide a list of acceptable manufactures for all listed equipment.

A: RTUs – Trane, Carrier, McQuay, JCI, Aaon.

ERV – Renewaire, Greenheck.

Booster Coils – Trane, Carrier, McQuay, JCI, Greenheck.

Grilles – Open to any manufacturer meeting the scheduled data.



Alternative manufacturers can be submitted during the bidding period (not during the submittal process) for approval if desired.

Specifications

Sheet A901-General Building Specifications

Division 10 Specialties

Delete: Delete H.

Clarify: A. Scranton Products (HDPE) bathroom partitions.

Drawings

Sheet A101 – TITLE SHEET

Add: Add Wall Type "B" See Drawing.

Sheet A301 – PARTIAL FIRST FLOOR DEMOLITION PLAN, PARTIAL FIRST FLOOR PLAN, DEMOLITION NOTES, FLOOR PLAN NOTES, AND GENERAL PLAN NOTES

Partial First Floor Plan – Demolition plan 1/A301

Clarify: Clarify cut opening dimension. See drawing.

Partial First Floor Plan – 2/A301

Add: Add metal stud wall in Woman's Toilet 105. See drawing.

Add: Add fire extinguisher in Existing Locker Room 102 and Women's Toilet 105. See drawing.

Floor Plan Keynotes

Add: Add keynote no. 5 – fire extinguisher – by owner.

General Demo Plan notes

Add: Add note to patch and repair duct opening(s) between toilet rooms. See drawing.

Sheet A302 – PARTIAL REFLECTED CEILING PLAN, PARTIAL DEMOLITION ROOF PLAN, ROOM FINISH SCHEDULE, DOOR SCHEDULE, PAINT TYPE AND DETAILS

Partial Reflected Ceiling Plan 1/A302



Clarify: Clarify ceiling material in rooms 103, 104A, 104B, 105 and 106. See drawing.

Add: Add Sound Attenuation to Women's Locker 104A, and Showers 104B and 104C. See drawing.

Head/Jamb Detail 2/A302

Clarify: Clarify steel lintel sizing to W8X10 w/ 1/4" bottom plate. See drawing.

Partial Demolition Roof Plan 3/A302

Add: Added note to clarify all cutting and patching to accommodate new construction is done by owner. See drawing.

Room Finish Schedule

Clarify: Clarify base material, wall finish/materials ceiling materials and door remarks. See drawing.

Room finish remarks

Add: Added No. 3 remark to room finish remark. See drawing.

Sheet A303 - ENLARGED TOILET/LOCKER/SHOWER ROOM PLANS, TOILET ROOM ELEVATIONS, TOILET ROOM ACCESSORIES AND DETAILS

Enlarged Toilet/Locker/Shower Room 1/A303

Revise: Revised CMU thickness on south wall of Women's Shower 104C, which allowed ADA bench to be 42." See drawing.

Add: Add toilet paper dispensers in toilet stalls. See drawing.

Add: Add metal stud wall in woman's toilet 105, and tagged wall type "B." See drawing.

Add: Add room tag in men's and women's shower. See drawing.

Toilet Room Elevations

Add: Add toilet paper dispenser 15" min from finished floor. See drawing.

Toilet Room Elevations 2/A303



Clarify: Clarify countertop material to be solid surface – price color B. See drawing.

Accessible Signage Detail

Add: Add note accessible signage by owner. See Drawing.

Accessible Transfer shower detail 8/A303

Clarify: Clarify ADA shower stall dimension is 3'-0" finish wall to wall. See Drawing.

Toilet Room Keynotes

Add: Add keynote 9- toilet paper dispenser. See Drawing

Drawings – Mechanical

Sheet M300 – Schedules & Details

Motor Starter & Electrical Connection Schedule:

Revise: Revise ERV-1 & RTU-1 electrical data to be 480V/3phase. See drawing.

Drawings – Electrical

Sheet E200 – Schedules & Details

Motor Schedule:

Revise: Revise ERV-1 & RTU-1 electrical data to be 480V/3phase. See drawing.

End of Addendum No. 2

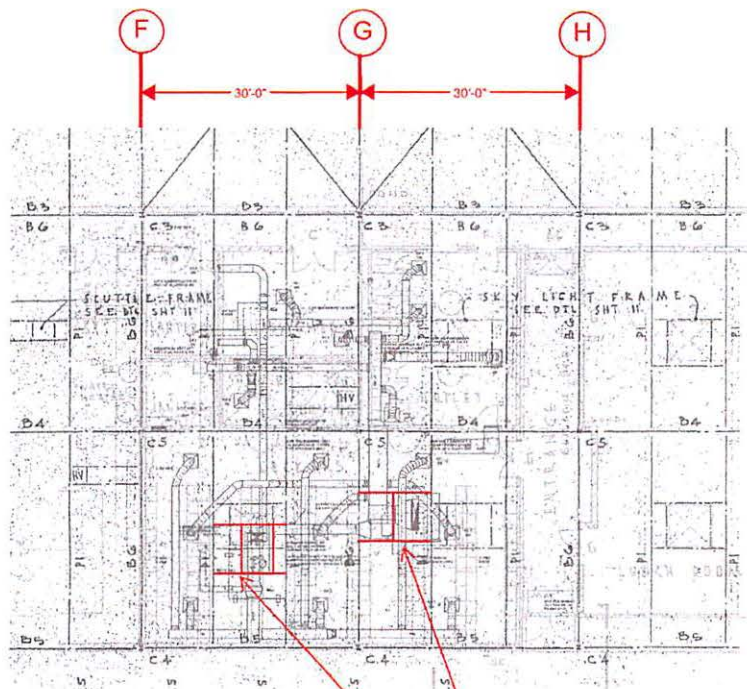

L5X3X1/4 (LLV) FRAME
TYPICAL AT RTU-1 AND
ERV-1

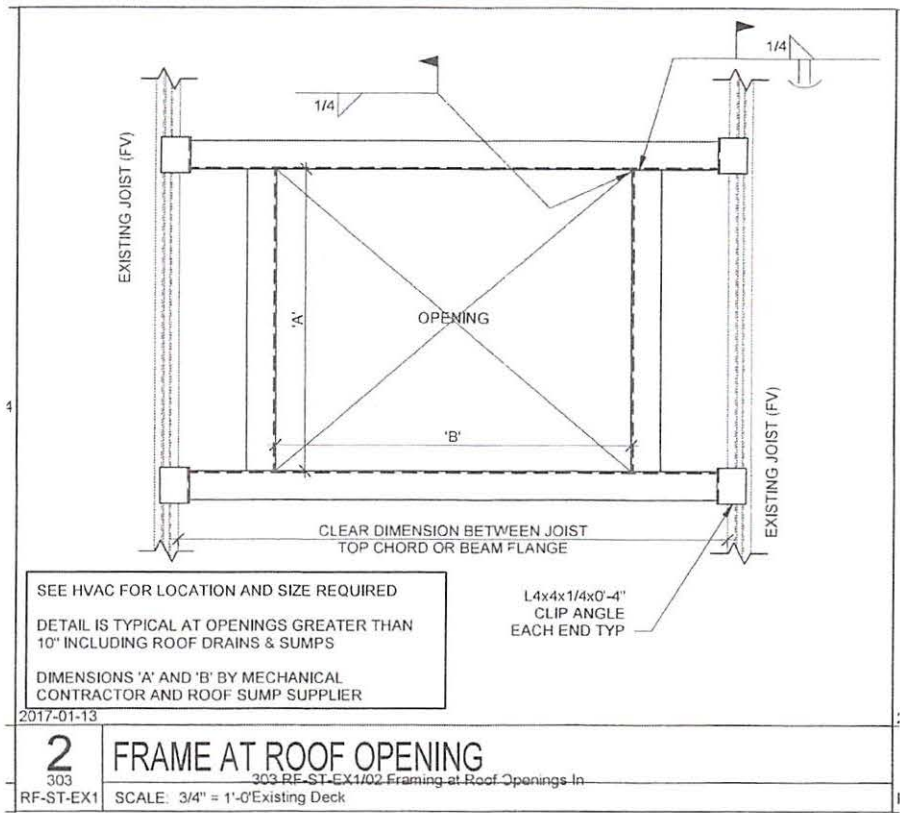

2017-01-13

2 FRAME AT ROOF OPENING

RF-ST-EX1 SCALE: 3/4" = 1'-0" Existing Deck

SHEBOYGAN DPW NEW RTU SUPPORT
09-10-19 MTB

LOCKER ROOM RENOVATIONS

CITY OF SHEBOYGAN DPW RENOVATION

2026 NEW JERSEY AVE, SHEBOYGAN, WI 53081



REVISIONS:
ADD: 5-16/2019

DATE: 5/16/2019
PROJECT: LOCKER ROOM RENOVATIONS
DRAWN BY: [blank]
CHECKED BY: [blank]

ABBREVIATIONS

SYMBOL	DESCRIPTION	SYMBOL	DESCRIPTION
1-1	CONCRETE	1-1	CONCRETE
1-2	CONCRETE	1-2	CONCRETE
1-3	CONCRETE	1-3	CONCRETE
1-4	CONCRETE	1-4	CONCRETE
1-5	CONCRETE	1-5	CONCRETE
1-6	CONCRETE	1-6	CONCRETE
1-7	CONCRETE	1-7	CONCRETE
1-8	CONCRETE	1-8	CONCRETE
1-9	CONCRETE	1-9	CONCRETE
1-10	CONCRETE	1-10	CONCRETE
1-11	CONCRETE	1-11	CONCRETE
1-12	CONCRETE	1-12	CONCRETE
1-13	CONCRETE	1-13	CONCRETE
1-14	CONCRETE	1-14	CONCRETE
1-15	CONCRETE	1-15	CONCRETE
1-16	CONCRETE	1-16	CONCRETE
1-17	CONCRETE	1-17	CONCRETE
1-18	CONCRETE	1-18	CONCRETE
1-19	CONCRETE	1-19	CONCRETE
1-20	CONCRETE	1-20	CONCRETE
1-21	CONCRETE	1-21	CONCRETE
1-22	CONCRETE	1-22	CONCRETE
1-23	CONCRETE	1-23	CONCRETE
1-24	CONCRETE	1-24	CONCRETE
1-25	CONCRETE	1-25	CONCRETE
1-26	CONCRETE	1-26	CONCRETE
1-27	CONCRETE	1-27	CONCRETE
1-28	CONCRETE	1-28	CONCRETE
1-29	CONCRETE	1-29	CONCRETE
1-30	CONCRETE	1-30	CONCRETE
1-31	CONCRETE	1-31	CONCRETE
1-32	CONCRETE	1-32	CONCRETE
1-33	CONCRETE	1-33	CONCRETE
1-34	CONCRETE	1-34	CONCRETE
1-35	CONCRETE	1-35	CONCRETE
1-36	CONCRETE	1-36	CONCRETE
1-37	CONCRETE	1-37	CONCRETE
1-38	CONCRETE	1-38	CONCRETE
1-39	CONCRETE	1-39	CONCRETE
1-40	CONCRETE	1-40	CONCRETE
1-41	CONCRETE	1-41	CONCRETE
1-42	CONCRETE	1-42	CONCRETE
1-43	CONCRETE	1-43	CONCRETE
1-44	CONCRETE	1-44	CONCRETE
1-45	CONCRETE	1-45	CONCRETE
1-46	CONCRETE	1-46	CONCRETE
1-47	CONCRETE	1-47	CONCRETE
1-48	CONCRETE	1-48	CONCRETE
1-49	CONCRETE	1-49	CONCRETE
1-50	CONCRETE	1-50	CONCRETE
1-51	CONCRETE	1-51	CONCRETE
1-52	CONCRETE	1-52	CONCRETE
1-53	CONCRETE	1-53	CONCRETE
1-54	CONCRETE	1-54	CONCRETE
1-55	CONCRETE	1-55	CONCRETE
1-56	CONCRETE	1-56	CONCRETE
1-57	CONCRETE	1-57	CONCRETE
1-58	CONCRETE	1-58	CONCRETE
1-59	CONCRETE	1-59	CONCRETE
1-60	CONCRETE	1-60	CONCRETE
1-61	CONCRETE	1-61	CONCRETE
1-62	CONCRETE	1-62	CONCRETE
1-63	CONCRETE	1-63	CONCRETE
1-64	CONCRETE	1-64	CONCRETE
1-65	CONCRETE	1-65	CONCRETE
1-66	CONCRETE	1-66	CONCRETE
1-67	CONCRETE	1-67	CONCRETE
1-68	CONCRETE	1-68	CONCRETE
1-69	CONCRETE	1-69	CONCRETE
1-70	CONCRETE	1-70	CONCRETE
1-71	CONCRETE	1-71	CONCRETE
1-72	CONCRETE	1-72	CONCRETE
1-73	CONCRETE	1-73	CONCRETE
1-74	CONCRETE	1-74	CONCRETE
1-75	CONCRETE	1-75	CONCRETE
1-76	CONCRETE	1-76	CONCRETE
1-77	CONCRETE	1-77	CONCRETE
1-78	CONCRETE	1-78	CONCRETE
1-79	CONCRETE	1-79	CONCRETE
1-80	CONCRETE	1-80	CONCRETE
1-81	CONCRETE	1-81	CONCRETE
1-82	CONCRETE	1-82	CONCRETE
1-83	CONCRETE	1-83	CONCRETE
1-84	CONCRETE	1-84	CONCRETE
1-85	CONCRETE	1-85	CONCRETE
1-86	CONCRETE	1-86	CONCRETE
1-87	CONCRETE	1-87	CONCRETE
1-88	CONCRETE	1-88	CONCRETE
1-89	CONCRETE	1-89	CONCRETE
1-90	CONCRETE	1-90	CONCRETE
1-91	CONCRETE	1-91	CONCRETE
1-92	CONCRETE	1-92	CONCRETE
1-93	CONCRETE	1-93	CONCRETE
1-94	CONCRETE	1-94	CONCRETE
1-95	CONCRETE	1-95	CONCRETE
1-96	CONCRETE	1-96	CONCRETE
1-97	CONCRETE	1-97	CONCRETE
1-98	CONCRETE	1-98	CONCRETE
1-99	CONCRETE	1-99	CONCRETE
1-100	CONCRETE	1-100	CONCRETE

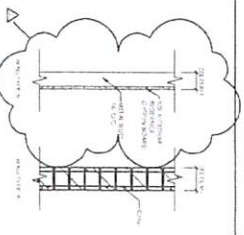
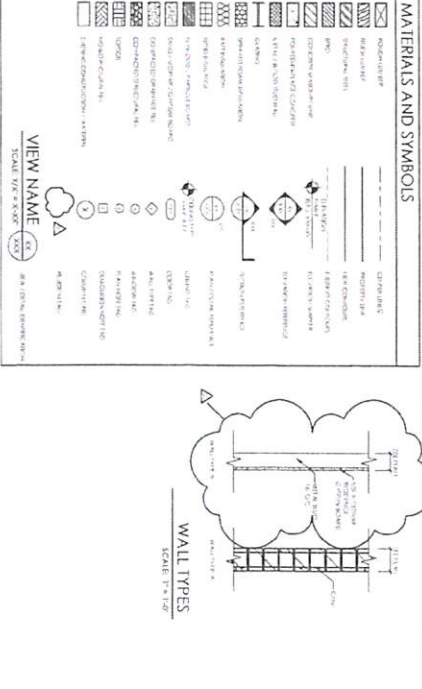

ARCHITECTURAL	STRUCTURAL	PLUMBING	H.V.A.C.	ELECTRICAL	PROJECT INFORMATION	PROJECT NOTES
<p>44000 ARCHITECT AND ENGINEER 1135A MICHIGAN AVENUE SHEBOYGAN, WI 53081</p> <p>1-101 REVISIONS 1-102 REVISIONS 1-103 REVISIONS 1-104 REVISIONS 1-105 REVISIONS 1-106 REVISIONS 1-107 REVISIONS 1-108 REVISIONS 1-109 REVISIONS 1-110 REVISIONS 1-111 REVISIONS 1-112 REVISIONS 1-113 REVISIONS 1-114 REVISIONS 1-115 REVISIONS 1-116 REVISIONS 1-117 REVISIONS 1-118 REVISIONS 1-119 REVISIONS 1-120 REVISIONS 1-121 REVISIONS 1-122 REVISIONS 1-123 REVISIONS 1-124 REVISIONS 1-125 REVISIONS 1-126 REVISIONS 1-127 REVISIONS 1-128 REVISIONS 1-129 REVISIONS 1-130 REVISIONS 1-131 REVISIONS 1-132 REVISIONS 1-133 REVISIONS 1-134 REVISIONS 1-135 REVISIONS 1-136 REVISIONS 1-137 REVISIONS 1-138 REVISIONS 1-139 REVISIONS 1-140 REVISIONS 1-141 REVISIONS 1-142 REVISIONS 1-143 REVISIONS 1-144 REVISIONS 1-145 REVISIONS 1-146 REVISIONS 1-147 REVISIONS 1-148 REVISIONS 1-149 REVISIONS 1-150 REVISIONS 1-151 REVISIONS 1-152 REVISIONS 1-153 REVISIONS 1-154 REVISIONS 1-155 REVISIONS 1-156 REVISIONS 1-157 REVISIONS 1-158 REVISIONS 1-159 REVISIONS 1-160 REVISIONS 1-161 REVISIONS 1-162 REVISIONS 1-163 REVISIONS 1-164 REVISIONS 1-165 REVISIONS 1-166 REVISIONS 1-167 REVISIONS 1-168 REVISIONS 1-169 REVISIONS 1-170 REVISIONS 1-171 REVISIONS 1-172 REVISIONS 1-173 REVISIONS 1-174 REVISIONS 1-175 REVISIONS 1-176 REVISIONS 1-177 REVISIONS 1-178 REVISIONS 1-179 REVISIONS 1-180 REVISIONS 1-181 REVISIONS 1-182 REVISIONS 1-183 REVISIONS 1-184 REVISIONS 1-185 REVISIONS 1-186 REVISIONS 1-187 REVISIONS 1-188 REVISIONS 1-189 REVISIONS 1-190 REVISIONS 1-191 REVISIONS 1-192 REVISIONS 1-193 REVISIONS 1-194 REVISIONS 1-195 REVISIONS 1-196 REVISIONS 1-197 REVISIONS 1-198 REVISIONS 1-199 REVISIONS 1-200 REVISIONS</p>	<p>44000 ARCHITECT AND ENGINEER 1135A MICHIGAN AVENUE SHEBOYGAN, WI 53081</p>	<p>44000 ARCHITECT AND ENGINEER 1135A MICHIGAN AVENUE SHEBOYGAN, WI 53081</p>	<p>44000 ARCHITECT AND ENGINEER 1135A MICHIGAN AVENUE SHEBOYGAN, WI 53081</p>	<p>44000 ARCHITECT AND ENGINEER 1135A MICHIGAN AVENUE SHEBOYGAN, WI 53081</p>	<p>44000 ARCHITECT AND ENGINEER 1135A MICHIGAN AVENUE SHEBOYGAN, WI 53081</p>	<p>44000 ARCHITECT AND ENGINEER 1135A MICHIGAN AVENUE SHEBOYGAN, WI 53081</p>

CITY OF SHEBOYGAN DPW RENOVATION
2026 NEW JERSEY AVE, SHEBOYGAN, WI 53081
1135A MICHIGAN AVE, SHEBOYGAN, WI 53081 | 920.432.4444 | 225 EAST ST, PAUL AVE, MILWAUKEE, WI 53202 | (414) 537-6400

BID SET

DRAWN BY: [blank]
CHECKED BY: [blank]

101

PROJ. NO. 2019-22

FLOOR PLAN KEYNOTES

NO.	DESCRIPTION
1	WALL EXISTING WALL OPENING WITH CONSTRUCTION TO MATCH EXISTING EXPOSED NEW SURFACE FLUSH WITH EXISTING ADJACENT SURFACES
2	2" FIBER GLASS BY OVERLAP
3	NEW CONCrete FLOOR TO MATCH EXISTING
4	WALL HEIGHT 8'-0", ALL NOTE CAUTION FOR OVERLAP
5	FIRE EXTINGUISHER BY OWNER

GENERAL PLAN NOTES

1	ALL EXISTING WALLS TO BE DEMOLISHED AND RECONSTRUCTED TO MATCH EXISTING WALLS AND FINISHES.
2	ALL EXISTING FLOORING TO BE DEMOLISHED AND RECONSTRUCTED TO MATCH EXISTING FLOORING AND FINISHES.
3	ALL EXISTING CEILING TO BE DEMOLISHED AND RECONSTRUCTED TO MATCH EXISTING CEILING AND FINISHES.
4	ALL EXISTING MECHANICAL AND ELECTRICAL TO BE DEMOLISHED AND RECONSTRUCTED TO MATCH EXISTING MECHANICAL AND ELECTRICAL AND FINISHES.
5	ALL EXISTING PARTITIONS TO BE DEMOLISHED AND RECONSTRUCTED TO MATCH EXISTING PARTITIONS AND FINISHES.
6	ALL EXISTING DOORS TO BE DEMOLISHED AND RECONSTRUCTED TO MATCH EXISTING DOORS AND FINISHES.
7	ALL EXISTING WINDOWS TO BE DEMOLISHED AND RECONSTRUCTED TO MATCH EXISTING WINDOWS AND FINISHES.
8	ALL EXISTING LIGHT FIXTURES TO BE DEMOLISHED AND RECONSTRUCTED TO MATCH EXISTING LIGHT FIXTURES AND FINISHES.
9	ALL EXISTING CASES TO BE DEMOLISHED AND RECONSTRUCTED TO MATCH EXISTING CASES AND FINISHES.
10	ALL EXISTING CABINETS TO BE DEMOLISHED AND RECONSTRUCTED TO MATCH EXISTING CABINETS AND FINISHES.
11	ALL EXISTING TUBS AND SHOWERS TO BE DEMOLISHED AND RECONSTRUCTED TO MATCH EXISTING TUBS AND SHOWERS AND FINISHES.
12	ALL EXISTING TOILETS TO BE DEMOLISHED AND RECONSTRUCTED TO MATCH EXISTING TOILETS AND FINISHES.
13	ALL EXISTING SINKS TO BE DEMOLISHED AND RECONSTRUCTED TO MATCH EXISTING SINKS AND FINISHES.
14	ALL EXISTING VANITIES TO BE DEMOLISHED AND RECONSTRUCTED TO MATCH EXISTING VANITIES AND FINISHES.
15	ALL EXISTING BATHS TO BE DEMOLISHED AND RECONSTRUCTED TO MATCH EXISTING BATHS AND FINISHES.
16	ALL EXISTING KITCHENS TO BE DEMOLISHED AND RECONSTRUCTED TO MATCH EXISTING KITCHENS AND FINISHES.
17	ALL EXISTING BREAK ROOMS TO BE DEMOLISHED AND RECONSTRUCTED TO MATCH EXISTING BREAK ROOMS AND FINISHES.
18	ALL EXISTING OFFICES TO BE DEMOLISHED AND RECONSTRUCTED TO MATCH EXISTING OFFICES AND FINISHES.
19	ALL EXISTING CONFERENCE ROOMS TO BE DEMOLISHED AND RECONSTRUCTED TO MATCH EXISTING CONFERENCE ROOMS AND FINISHES.
20	ALL EXISTING STORAGE ROOMS TO BE DEMOLISHED AND RECONSTRUCTED TO MATCH EXISTING STORAGE ROOMS AND FINISHES.
21	ALL EXISTING LOCKER ROOMS TO BE DEMOLISHED AND RECONSTRUCTED TO MATCH EXISTING LOCKER ROOMS AND FINISHES.
22	ALL EXISTING RESTROOMS TO BE DEMOLISHED AND RECONSTRUCTED TO MATCH EXISTING RESTROOMS AND FINISHES.
23	ALL EXISTING JANITORIES TO BE DEMOLISHED AND RECONSTRUCTED TO MATCH EXISTING JANITORIES AND FINISHES.
24	ALL EXISTING MECHANICAL ROOMS TO BE DEMOLISHED AND RECONSTRUCTED TO MATCH EXISTING MECHANICAL ROOMS AND FINISHES.
25	ALL EXISTING ELECTRICAL ROOMS TO BE DEMOLISHED AND RECONSTRUCTED TO MATCH EXISTING ELECTRICAL ROOMS AND FINISHES.
26	ALL EXISTING TELEPHONE ROOMS TO BE DEMOLISHED AND RECONSTRUCTED TO MATCH EXISTING TELEPHONE ROOMS AND FINISHES.
27	ALL EXISTING STORAGE CLOSETS TO BE DEMOLISHED AND RECONSTRUCTED TO MATCH EXISTING STORAGE CLOSETS AND FINISHES.
28	ALL EXISTING ENTRYWAYS TO BE DEMOLISHED AND RECONSTRUCTED TO MATCH EXISTING ENTRYWAYS AND FINISHES.
29	ALL EXISTING CORRIDORS TO BE DEMOLISHED AND RECONSTRUCTED TO MATCH EXISTING CORRIDORS AND FINISHES.
30	ALL EXISTING STAIRWAYS TO BE DEMOLISHED AND RECONSTRUCTED TO MATCH EXISTING STAIRWAYS AND FINISHES.
31	ALL EXISTING ELEVATOR SHAFTS TO BE DEMOLISHED AND RECONSTRUCTED TO MATCH EXISTING ELEVATOR SHAFTS AND FINISHES.
32	ALL EXISTING MECHANICAL SHAFTS TO BE DEMOLISHED AND RECONSTRUCTED TO MATCH EXISTING MECHANICAL SHAFTS AND FINISHES.
33	ALL EXISTING ELECTRICAL SHAFTS TO BE DEMOLISHED AND RECONSTRUCTED TO MATCH EXISTING ELECTRICAL SHAFTS AND FINISHES.
34	ALL EXISTING TELEPHONE SHAFTS TO BE DEMOLISHED AND RECONSTRUCTED TO MATCH EXISTING TELEPHONE SHAFTS AND FINISHES.
35	ALL EXISTING STORAGE SHAFTS TO BE DEMOLISHED AND RECONSTRUCTED TO MATCH EXISTING STORAGE SHAFTS AND FINISHES.
36	ALL EXISTING LOCKER SHAFTS TO BE DEMOLISHED AND RECONSTRUCTED TO MATCH EXISTING LOCKER SHAFTS AND FINISHES.
37	ALL EXISTING RESTROOM SHAFTS TO BE DEMOLISHED AND RECONSTRUCTED TO MATCH EXISTING RESTROOM SHAFTS AND FINISHES.
38	ALL EXISTING JANITORY SHAFTS TO BE DEMOLISHED AND RECONSTRUCTED TO MATCH EXISTING JANITORY SHAFTS AND FINISHES.
39	ALL EXISTING MECHANICAL SHAFTS TO BE DEMOLISHED AND RECONSTRUCTED TO MATCH EXISTING MECHANICAL SHAFTS AND FINISHES.
40	ALL EXISTING ELECTRICAL SHAFTS TO BE DEMOLISHED AND RECONSTRUCTED TO MATCH EXISTING ELECTRICAL SHAFTS AND FINISHES.
41	ALL EXISTING TELEPHONE SHAFTS TO BE DEMOLISHED AND RECONSTRUCTED TO MATCH EXISTING TELEPHONE SHAFTS AND FINISHES.
42	ALL EXISTING STORAGE SHAFTS TO BE DEMOLISHED AND RECONSTRUCTED TO MATCH EXISTING STORAGE SHAFTS AND FINISHES.
43	ALL EXISTING LOCKER SHAFTS TO BE DEMOLISHED AND RECONSTRUCTED TO MATCH EXISTING LOCKER SHAFTS AND FINISHES.
44	ALL EXISTING RESTROOM SHAFTS TO BE DEMOLISHED AND RECONSTRUCTED TO MATCH EXISTING RESTROOM SHAFTS AND FINISHES.
45	ALL EXISTING JANITORY SHAFTS TO BE DEMOLISHED AND RECONSTRUCTED TO MATCH EXISTING JANITORY SHAFTS AND FINISHES.
46	ALL EXISTING MECHANICAL SHAFTS TO BE DEMOLISHED AND RECONSTRUCTED TO MATCH EXISTING MECHANICAL SHAFTS AND FINISHES.
47	ALL EXISTING ELECTRICAL SHAFTS TO BE DEMOLISHED AND RECONSTRUCTED TO MATCH EXISTING ELECTRICAL SHAFTS AND FINISHES.
48	ALL EXISTING TELEPHONE SHAFTS TO BE DEMOLISHED AND RECONSTRUCTED TO MATCH EXISTING TELEPHONE SHAFTS AND FINISHES.
49	ALL EXISTING STORAGE SHAFTS TO BE DEMOLISHED AND RECONSTRUCTED TO MATCH EXISTING STORAGE SHAFTS AND FINISHES.
50	ALL EXISTING LOCKER SHAFTS TO BE DEMOLISHED AND RECONSTRUCTED TO MATCH EXISTING LOCKER SHAFTS AND FINISHES.

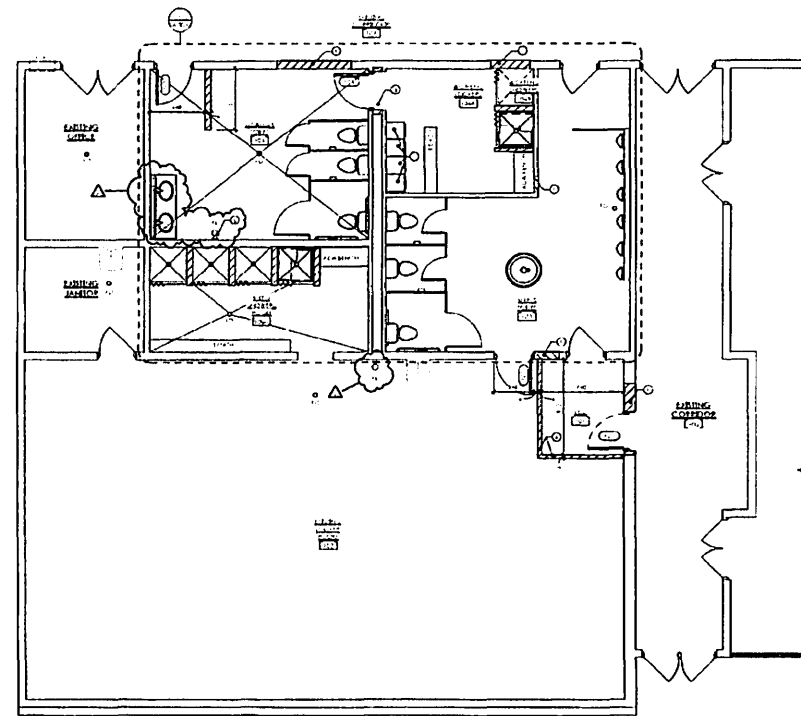

PARTIAL FIRST FLOOR PLAN
SCALE 1/4" = 1'-0"
N
W
E
S

GENERAL DEMO PLAN NOTES

1	REMOVE EXISTING WALLS AND PARTITIONS TO MATCH EXISTING WALLS AND FINISHES.
2	REMOVE EXISTING FLOORING TO MATCH EXISTING FLOORING AND FINISHES.
3	REMOVE EXISTING CEILING TO MATCH EXISTING CEILING AND FINISHES.
4	REMOVE EXISTING MECHANICAL AND ELECTRICAL TO MATCH EXISTING MECHANICAL AND ELECTRICAL AND FINISHES.
5	REMOVE EXISTING PARTITIONS TO MATCH EXISTING PARTITIONS AND FINISHES.
6	REMOVE EXISTING DOORS TO MATCH EXISTING DOORS AND FINISHES.
7	REMOVE EXISTING WINDOWS TO MATCH EXISTING WINDOWS AND FINISHES.
8	REMOVE EXISTING LIGHT FIXTURES TO MATCH EXISTING LIGHT FIXTURES AND FINISHES.
9	REMOVE EXISTING CASES TO MATCH EXISTING CASES AND FINISHES.
10	REMOVE EXISTING CABINETS TO MATCH EXISTING CABINETS AND FINISHES.
11	REMOVE EXISTING TUBS AND SHOWERS TO MATCH EXISTING TUBS AND SHOWERS AND FINISHES.
12	REMOVE EXISTING TOILETS TO MATCH EXISTING TOILETS AND FINISHES.
13	REMOVE EXISTING SINKS TO MATCH EXISTING SINKS AND FINISHES.
14	REMOVE EXISTING VANITIES TO MATCH EXISTING VANITIES AND FINISHES.
15	REMOVE EXISTING BATHS TO MATCH EXISTING BATHS AND FINISHES.
16	REMOVE EXISTING KITCHENS TO MATCH EXISTING KITCHENS AND FINISHES.
17	REMOVE EXISTING BREAK ROOMS TO MATCH EXISTING BREAK ROOMS AND FINISHES.
18	REMOVE EXISTING OFFICES TO MATCH EXISTING OFFICES AND FINISHES.
19	REMOVE EXISTING CONFERENCE ROOMS TO MATCH EXISTING CONFERENCE ROOMS AND FINISHES.
20	REMOVE EXISTING STORAGE ROOMS TO MATCH EXISTING STORAGE ROOMS AND FINISHES.
21	REMOVE EXISTING LOCKER ROOMS TO MATCH EXISTING LOCKER ROOMS AND FINISHES.
22	REMOVE EXISTING RESTROOMS TO MATCH EXISTING RESTROOMS AND FINISHES.
23	REMOVE EXISTING JANITORIES TO MATCH EXISTING JANITORIES AND FINISHES.
24	REMOVE EXISTING MECHANICAL ROOMS TO MATCH EXISTING MECHANICAL ROOMS AND FINISHES.
25	REMOVE EXISTING ELECTRICAL ROOMS TO MATCH EXISTING ELECTRICAL ROOMS AND FINISHES.
26	REMOVE EXISTING TELEPHONE ROOMS TO MATCH EXISTING TELEPHONE ROOMS AND FINISHES.
27	REMOVE EXISTING STORAGE CLOSETS TO MATCH EXISTING STORAGE CLOSETS AND FINISHES.
28	REMOVE EXISTING ENTRYWAYS TO MATCH EXISTING ENTRYWAYS AND FINISHES.
29	REMOVE EXISTING CORRIDORS TO MATCH EXISTING CORRIDORS AND FINISHES.
30	REMOVE EXISTING STAIRWAYS TO MATCH EXISTING STAIRWAYS AND FINISHES.
31	REMOVE EXISTING ELEVATOR SHAFTS TO MATCH EXISTING ELEVATOR SHAFTS AND FINISHES.
32	REMOVE EXISTING MECHANICAL SHAFTS TO MATCH EXISTING MECHANICAL SHAFTS AND FINISHES.
33	REMOVE EXISTING ELECTRICAL SHAFTS TO MATCH EXISTING ELECTRICAL SHAFTS AND FINISHES.
34	REMOVE EXISTING TELEPHONE SHAFTS TO MATCH EXISTING TELEPHONE SHAFTS AND FINISHES.
35	REMOVE EXISTING STORAGE SHAFTS TO MATCH EXISTING STORAGE SHAFTS AND FINISHES.
36	REMOVE EXISTING LOCKER SHAFTS TO MATCH EXISTING LOCKER SHAFTS AND FINISHES.
37	REMOVE EXISTING RESTROOM SHAFTS TO MATCH EXISTING RESTROOM SHAFTS AND FINISHES.
38	REMOVE EXISTING JANITORY SHAFTS TO MATCH EXISTING JANITORY SHAFTS AND FINISHES.
39	REMOVE EXISTING MECHANICAL SHAFTS TO MATCH EXISTING MECHANICAL SHAFTS AND FINISHES.
40	REMOVE EXISTING ELECTRICAL SHAFTS TO MATCH EXISTING ELECTRICAL SHAFTS AND FINISHES.
41	REMOVE EXISTING TELEPHONE SHAFTS TO MATCH EXISTING TELEPHONE SHAFTS AND FINISHES.
42	REMOVE EXISTING STORAGE SHAFTS TO MATCH EXISTING STORAGE SHAFTS AND FINISHES.
43	REMOVE EXISTING LOCKER SHAFTS TO MATCH EXISTING LOCKER SHAFTS AND FINISHES.
44	REMOVE EXISTING RESTROOM SHAFTS TO MATCH EXISTING RESTROOM SHAFTS AND FINISHES.
45	REMOVE EXISTING JANITORY SHAFTS TO MATCH EXISTING JANITORY SHAFTS AND FINISHES.
46	REMOVE EXISTING MECHANICAL SHAFTS TO MATCH EXISTING MECHANICAL SHAFTS AND FINISHES.
47	REMOVE EXISTING ELECTRICAL SHAFTS TO MATCH EXISTING ELECTRICAL SHAFTS AND FINISHES.
48	REMOVE EXISTING TELEPHONE SHAFTS TO MATCH EXISTING TELEPHONE SHAFTS AND FINISHES.
49	REMOVE EXISTING STORAGE SHAFTS TO MATCH EXISTING STORAGE SHAFTS AND FINISHES.
50	REMOVE EXISTING LOCKER SHAFTS TO MATCH EXISTING LOCKER SHAFTS AND FINISHES.

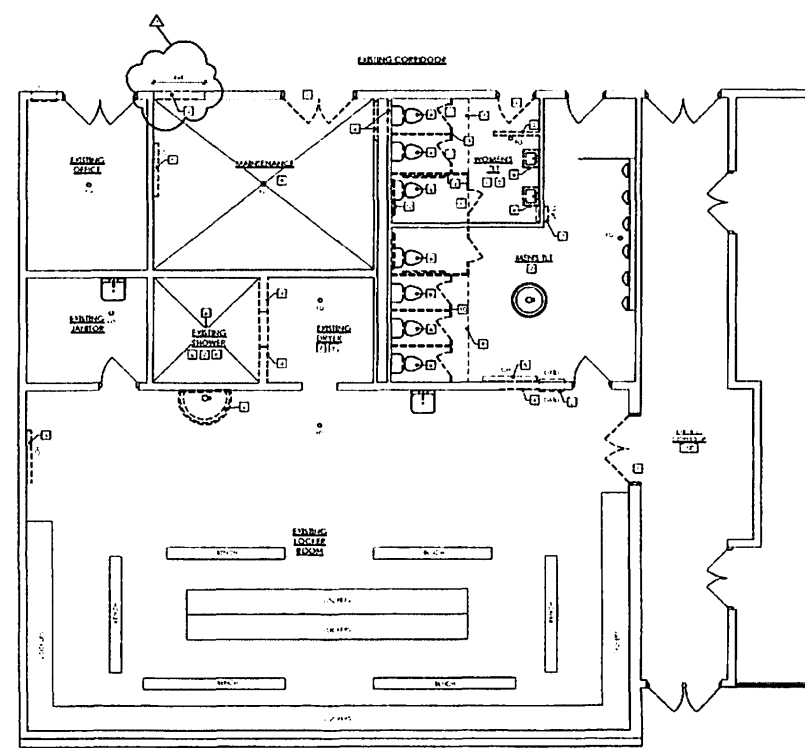

PARTIAL FIRST FLOOR- DEMOLITION PLAN
SCALE 1/4" = 1'-0"
N
W
E
S

DEMOLITION PLAN KEYNOTES

NO.	DESCRIPTION
1	REMOVE EXISTING DOOR & FRAME (VERIFY CONSTRUCTION) SALVAGE FOR REUSE. PREP ADJACENT SURFACES AS REQUIRED FOR NEW CONSTRUCTION.
2	REMOVE EXISTING GABRIEL PATCH TO MATCH EXISTING
3	REMOVE EXISTING WALL AND PREP ADJACENT SURFACES AS REQUIRED FOR NEW CONSTRUCTION
4	CUT OPENING IN EXISTING WALL FOR NEW CONSTRUCTION. PREP ADJACENT SURFACES AS REQUIRED FOR NEW CONSTRUCTION.
5	REMOVE CABINET HEATER.
6	REMOVE EXISTING PLUMBING FIXTURE. PREPARE FOR NEW CONSTRUCTION.
7	REMOVE EXISTING CEILING ASSEMBLY & LIGHT FIXTURES.
8	REMOVE FLOOR FINISH & BASE TO ACCOMMODATE NEW CONSTRUCTION. COORDINATE WITH PLUMBING.
9	REMOVE EXISTING SLOPPED TO ACCOMMODATE NEW CONSTRUCTION.
10	REMOVE TOILET PARTITION, GRAB BARS AND ACCESSORIES IN EXISTING TOILET ROOM.

NOTE:
SEE PLUMBING, HVAC AND ELECTRICAL PLANS FOR ADDITIONAL INFORMATION.



REVIEWS:
ADD # 2-10/16/2019

SEE PLUMBING, HVAC AND ELECTRICAL PLANS FOR ADDITIONAL INFORMATION.

LOCKER ROOM RENOVATIONS
 CITY OF SHEBOYGAN DPW RENOVATION
 2026 NEW JERSEY AVE. SHEBOYGAN, WI 53081
 1155A WISCONSIN AVE. SHEBOYGAN, WI 53081, P.O. BOX 402-0000, 1.252.545.3171 FAX 1.252.545.3172

BID SET

DRAWN BY: GJP
 CHECKED BY: EJD
 A
 301
 PROJ. NO. 2019-22



ALL SHOWER WALLS, CURTAINS AND ACCESSORIES SHALL BE INSTALLED TO BE ACCESSIBLE TO ALL PEOPLE WITH MOBILITY LIMITS.

ALL SHOWER WALLS, CURTAINS AND ACCESSORIES SHALL BE INSTALLED TO BE ACCESSIBLE TO ALL PEOPLE WITH MOBILITY LIMITS.

ACCESSIBLE TOILET ROOM ACCESSORIES DETAIL
SCALE: 1/2" = 1'-0" (A-303)

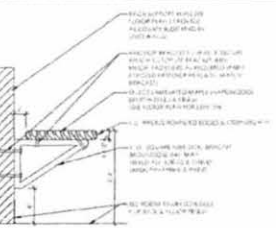
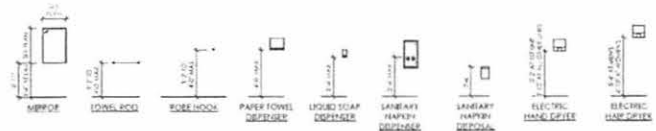

CONT. WALL BENCH DETAIL
SCALE: 1/2" = 1'-0" (A-303)

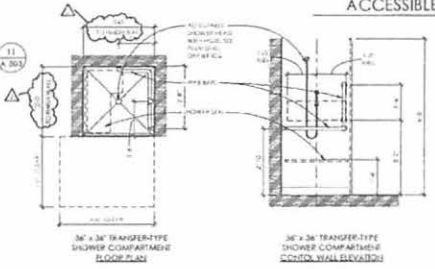

ACCESSIBLE TRANSFER SHOWER DETAIL
SCALE: 1/2" = 1'-0" (A-303)

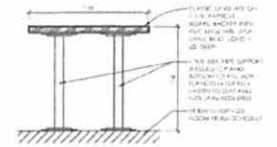

ACCESSIBLE BENCH DETAIL
SCALE: 1/2" = 1'-0" (A-303)

ACCESSIBLE SIGNAGE DETAIL
SCALE: 1/2" = 1'-0" (A-303)

TOILET ROOM KEYNOTES

KEY	DESCRIPTION
1	1/2" GRAB BAR
2	1/2" GRAB BAR
3	1/2" GRAB BAR
4	IMPURCE - SEE ELEVATION FOR SITE
5	TYPICAL SHOWER STALL - SEE TRASH SCHEDULE
6	SHOWER SEAT - WALL MOUNTED AT 18" AFF
7	SHOWER CURTAIN AND CURTAIN ROD - MOUNTED 18" AFF
8	TOILET PAPER DISPENSER

- GENERAL PLAN NOTES**
- ALL TOILET ROOMS SHALL BE ACCESSIBLE TO ALL PEOPLE WITH MOBILITY LIMITS.
 - ALL TOILET ROOMS SHALL BE ACCESSIBLE TO ALL PEOPLE WITH MOBILITY LIMITS.
 - ALL TOILET ROOMS SHALL BE ACCESSIBLE TO ALL PEOPLE WITH MOBILITY LIMITS.
 - ALL TOILET ROOMS SHALL BE ACCESSIBLE TO ALL PEOPLE WITH MOBILITY LIMITS.
 - ALL TOILET ROOMS SHALL BE ACCESSIBLE TO ALL PEOPLE WITH MOBILITY LIMITS.
 - ALL TOILET ROOMS SHALL BE ACCESSIBLE TO ALL PEOPLE WITH MOBILITY LIMITS.
 - ALL TOILET ROOMS SHALL BE ACCESSIBLE TO ALL PEOPLE WITH MOBILITY LIMITS.
 - ALL TOILET ROOMS SHALL BE ACCESSIBLE TO ALL PEOPLE WITH MOBILITY LIMITS.
 - ALL TOILET ROOMS SHALL BE ACCESSIBLE TO ALL PEOPLE WITH MOBILITY LIMITS.
 - ALL TOILET ROOMS SHALL BE ACCESSIBLE TO ALL PEOPLE WITH MOBILITY LIMITS.

TOILET ROOM ELEVATION
SCALE: 1/2" = 1'-0" (A-303)

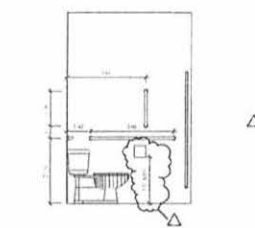

TOILET ROOM ELEVATION
SCALE: 1/2" = 1'-0" (A-303)

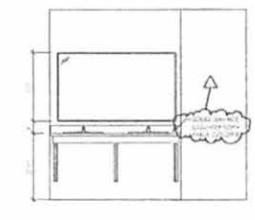

TOILET ROOM ELEVATION
SCALE: 1/2" = 1'-0" (A-303)

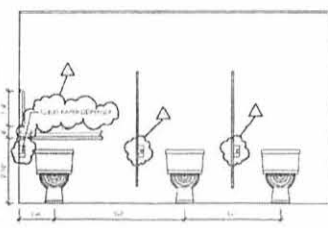

TOILET ROOM ELEVATION
SCALE: 1/2" = 1'-0" (A-303)

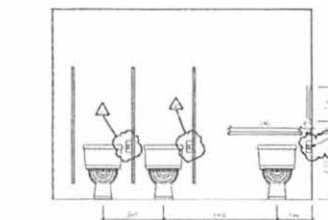

TOILET ROOM ELEVATION
SCALE: 1/2" = 1'-0" (A-303)

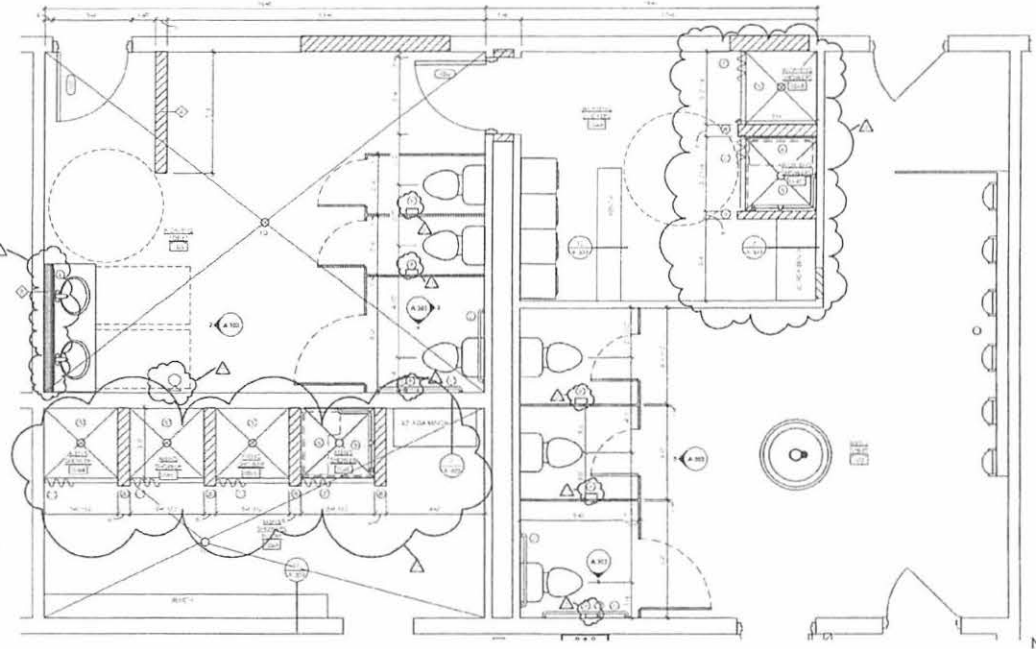

ENLARGED TOILET/LOCKER/SHOWER ROOM
SCALE: 1/2" = 1'-0" (A-303)

LOCER ROOM RENOVATIONS
CITY OF SHEBOYGAN DPW RENOVATION
2026 NEW JERSEY AVE. SHEBOYGAN, WI 53081
LISA MICHIGAN AVE. SHEBOYGAN, WI 53081
100 EAST ST. PAUL, ILL. 62450
INDIANAPOLIS, IN 46204

DRAWN BY: GJK
CHECKED BY: KED

A
303

MOTOR STARTER & ELECTRICAL CONNECTIONS															
TAG	EQUIPMENT TAG	FUNCTION	MOTOR DATA					ELECTRICAL DATA					NOTES		
			HP	VOLTS	PHASES	AMPS	FLA	TERMINAL	WIRING	CONTROL	STARTER	PROTECTION		REMARKS	
1001	1001-1	1001-1	1/2	230	3	1.5	1.5	1.5	1.5	1.5	1.5	1.5	1.5	1.5	
1002	1002-1	1002-1	1/2	230	3	1.5	1.5	1.5	1.5	1.5	1.5	1.5	1.5		

EQUIPMENT SUPPORT COORDINATION														
TAG	EQUIPMENT TAG	EQUIPMENT	SUPPORT DATA					ELECTRICAL DATA					NOTES	
			TYPE	LOCATION	HEIGHT	WIRING	CONTROL	TERMINAL	WIRING	CONTROL	STARTER	PROTECTION		REMARKS
1001	1001-1	1001-1	1/2	230	3	1.5	1.5	1.5	1.5	1.5	1.5	1.5	1.5	

- 1. ALL MOTOR STARTERS TO BE INSTALLED IN ACCORDANCE WITH ALL APPLICABLE CODES.
- 2. ALL WIRING TO BE INSTALLED IN ACCORDANCE WITH ALL APPLICABLE CODES.
- 3. ALL EQUIPMENT TO BE INSTALLED IN ACCORDANCE WITH ALL APPLICABLE CODES.

GRILLES, REGISTERS, & DIFFUSERS														
TAG	UNIT TAG	FUNCTION	GRILLE DATA					REGISTER DATA					NOTES	
			TYPE	SIZE	LOCATION	WIRING	CONTROL	TERMINAL	WIRING	CONTROL	STARTER	PROTECTION		REMARKS
1001	1001-1	1001-1	1/2	230	3	1.5	1.5	1.5	1.5	1.5	1.5	1.5	1.5	

- 1. ALL GRILLES, REGISTERS, & DIFFUSERS TO BE INSTALLED IN ACCORDANCE WITH ALL APPLICABLE CODES.

ROOFTOP UNITS														
TAG	UNIT TAG	FUNCTION	UNIT DATA					ELECTRICAL DATA					NOTES	
			TYPE	SIZE	LOCATION	WIRING	CONTROL	TERMINAL	WIRING	CONTROL	STARTER	PROTECTION		REMARKS
1001	1001-1	1001-1	1/2	230	3	1.5	1.5	1.5	1.5	1.5	1.5	1.5	1.5	

- 1. ALL ROOFTOP UNITS TO BE INSTALLED IN ACCORDANCE WITH ALL APPLICABLE CODES.
- 2. ALL WIRING TO BE INSTALLED IN ACCORDANCE WITH ALL APPLICABLE CODES.
- 3. ALL EQUIPMENT TO BE INSTALLED IN ACCORDANCE WITH ALL APPLICABLE CODES.

ENERGY RECOVERY VENTILATOR														
TAG	UNIT TAG	FUNCTION	UNIT DATA					ELECTRICAL DATA					NOTES	
			TYPE	SIZE	LOCATION	WIRING	CONTROL	TERMINAL	WIRING	CONTROL	STARTER	PROTECTION		REMARKS
1001	1001-1	1001-1	1/2	230	3	1.5	1.5	1.5	1.5	1.5	1.5	1.5	1.5	

- 1. ALL ENERGY RECOVERY VENTILATORS TO BE INSTALLED IN ACCORDANCE WITH ALL APPLICABLE CODES.

BOOSTER COILS														
TAG	UNIT TAG	FUNCTION	UNIT DATA					ELECTRICAL DATA					NOTES	
			TYPE	SIZE	LOCATION	WIRING	CONTROL	TERMINAL	WIRING	CONTROL	STARTER	PROTECTION		REMARKS
1001	1001-1	1001-1	1/2	230	3	1.5	1.5	1.5	1.5	1.5	1.5	1.5	1.5	

- 1. ALL BOOSTER COILS TO BE INSTALLED IN ACCORDANCE WITH ALL APPLICABLE CODES.

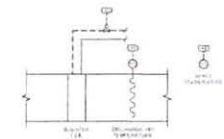

1 BOOSTER COIL SCHEMATIC

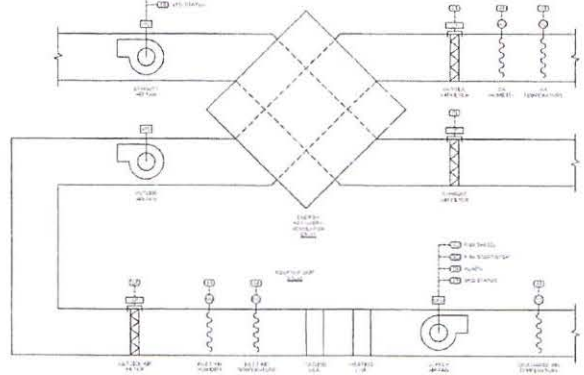

2 ROOFTOP UNIT & ENERGY RECOVERY VENTILATOR SCHEMATIC

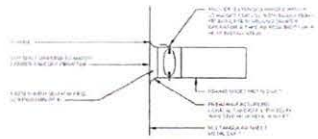

3 ROUND DUCT TAP CONNECTION DETAIL

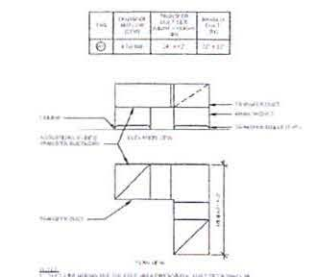

4 TRANSFER DUCT DETAIL

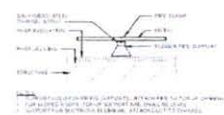

5 RUBBER SUPPORT RAIL DETAIL

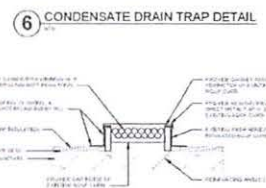

6 CONDENSATE DRAIN TRAP DETAIL



7 EXISTING ROOF CURB CAP DETAIL

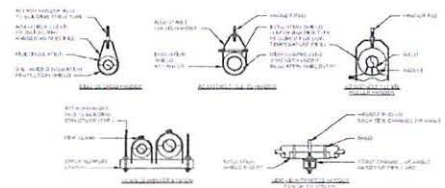

8 PIPE HANGERS & SUPPORTS DETAIL



9 TERMINAL UNIT HEATING COIL DETAIL



10 ROOF MOUNTED ROOFTOP UNIT DETAIL

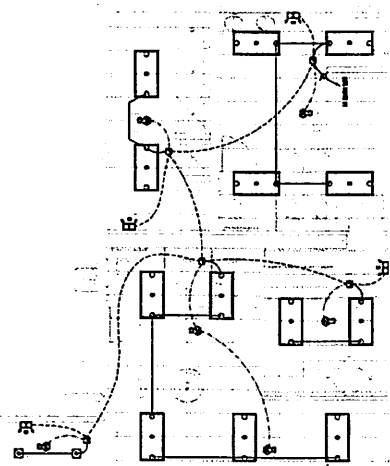

PARTIAL FIRST FLOOR LIGHTING PLAN

1. ALL FIXTURES SHALL BE INSTALLED IN ACCORDANCE WITH THE MANUFACTURER'S INSTALLATION INSTRUCTIONS.
 2. ALL WIRING SHALL BE IN ACCORDANCE WITH THE NATIONAL ELECTRICAL CODE (NEC) AND ALL LOCAL CODES.
 3. ALL WIRING SHALL BE IN ACCORDANCE WITH THE MANUFACTURER'S INSTALLATION INSTRUCTIONS.

PARTIAL FIRST FLOOR POWER PLAN

FIXTURE SCHEDULE

NO.	SYMBOL	TYPE	DESCRIPTION	QUANTITY	REMARKS
1	L1	RECESSED	4" SQUARE	1	
2	L2	RECESSED	4" SQUARE	1	
3	L3	RECESSED	4" SQUARE	1	
4	L4	RECESSED	4" SQUARE	1	
5	L5	RECESSED	4" SQUARE	1	
6	L6	RECESSED	4" SQUARE	1	
7	L7	RECESSED	4" SQUARE	1	
8	L8	RECESSED	4" SQUARE	1	
9	L9	RECESSED	4" SQUARE	1	
10	L10	RECESSED	4" SQUARE	1	

MOTOR SCHEDULE

NO.	SYMBOL	TYPE	DESCRIPTION	QUANTITY	REMARKS
1	M1	ELECTRIC	1/2 HP	1	
2	M2	ELECTRIC	1/2 HP	1	
3	M3	ELECTRIC	1/2 HP	1	
4	M4	ELECTRIC	1/2 HP	1	
5	M5	ELECTRIC	1/2 HP	1	
6	M6	ELECTRIC	1/2 HP	1	
7	M7	ELECTRIC	1/2 HP	1	
8	M8	ELECTRIC	1/2 HP	1	
9	M9	ELECTRIC	1/2 HP	1	
10	M10	ELECTRIC	1/2 HP	1	

REVISIONS

NO.	DATE	DESCRIPTION
1	08/10/2019	ISSUED FOR PERMIT



ABACUS ARCHITECTS
 226 EAST ST. PAUL, AVE. MILWAUKEE, WI 53202 (414) 837-4430
 1121A MCWYGAN AVE. SHEBOYGAN, WI 53081 (262) 457-4444
 SHEBOYGAN DPW RENOVATION
 LOCKER ROOM RENOVATION
 ISSUE DATE: AUGUST 30, 2019
 DRAWING NO. 200
 PROJECT NO. 19083

**Addendum #3**

Date October 18, 2019

City Of Sheboygan DPW Renovation2026 New Jersey Ave
Sheboygan, WI 53081

Abacus Architects, Inc. Project No. 2019-22

This addendum is issued to explain, modify or correct the original Specifications and drawings and is hereby made a part of the contract Documents. This addendum must be attached to the specifications in your possession.

Bid Clarification**HVAC**

- Clarify: Q: Control specifications are not included in the Construction Documents.
A: Controls specifications are provided on M000 to provide scope of work. Actual contract shall be directly through Owner.

Drawings**Sheet A101 – TITLE SHEET****Architect Title**

- Add:** Add sheet A304 Partial Finished Finish Floor Plan.

HVAC TITLE

- Add:** Add sheet M101 First Floor New Work Plan – Alternate.

Sheet A301 – PARTIAL FIRST FLOOR DEMOLITION PLAN, PARTIAL FIRST FLOOR PLAN, DEMOLITION NOTES, FLOOR PLAN NOTES, AND GENERAL PLAN NOTES**Partial First Floor Plan – 2/A301**

- Revised:** Revise door 104 and 105. See sheet 2/A301.
- Clarify:** Clarify ADA bench in Men's Shower Room 106A. See sheet 2/A301.
- Revised:** Revised Women's toilet and Men's toilet ADA stall door. See sheet 2/A301.



Delete: Delete one stall in women's toilet. See sheet 2/A301.

Floor Plan Keynotes

Revised: Revised keynote no. 1. See sheet A/301.

Sheet A302 – PARTIAL REFLECTED CEILING PLAN, PARTIAL DEMOLITION ROOF PLAN, ROOM FINISH SCHEDULE, DOOR SCHEDULE, PAINT TYPE AND DETAILS

Room Finish Schedule

Clarify: Clarify base material, wall finish/materials ceiling materials and door remarks. See sheet A/302.

Sheet A303 - ENLARGED TOILET/LOCKER/SHOWER ROOM PLANS, TOILET ROOM ELEVATIONS, TOILET ROOM ACCESSORIES AND DETAILS

Enlarged Toilet/Locker/Shower Room 1/A303

Revised: Revise door 104 and 105. See sheet 1/A303.

Revised: Revised Women's toilet and Men's toilet ADA stall door. See sheet 1/A303.

Delete: Delete one stall in women's toilet. See sheet 1/A303.

Sheet A304- PARTIAL FINISH PLAN A304

Add: Added new sheet. See sheet 1/A304.

Drawings – Mechanical

Sheet M101 – FIRST FLOOR NEW WORK PLAN - ALTERNATE

Add: Add new sheet. See sheet M/101

End of Addendum No. 3

ROOM FINISH SCHEDULE

ROOM	NAME	FLOOR	BASE	WALL FINISH MATERIAL				CEILING	CEILING HEIGHT	FLOOR METALS	WOOD TRIM	REMARKS
				NORTH	EAST	SOUTH	WEST					
100	EXIST'G CORRIDOR	1ST	FTB	-	-	-	-	ENG	-	-	3	
101	VEST	1ST	FTB	EXIST SGT	EXIST SGT	EXIST SGT	EXIST SGT	ACT-2	0-4	P-1	1,2,3	
102	EXIST'G LOCKER ROOM	1ST	FTB	P-1/SGT	P-1	-	-	ENG	0-4	P-1	1,2	
103	MEN'S TOILET	1ST	1ST	CMU P-1/EXIST SGT	EXIST SGT	EXIST SGT	EXIST SGT	ACT-3	0-2	P-1	1,3	
104A	WOMEN'S LOCKERS	1ST	FTB	CMU P-1/FT	CMU P-1	CMU P-1	EXIST SGT	ACT-2	0-2	P-1	-	
104B	WOMEN'S SHOWERS	1ST	FTB	FT	FT	FT	-	ACT-2	0-2	P-1	1	
104C	WOMEN'S SHOWERS	1ST	FTB	FT	FT	FT	-	ACT-2	0-2	P-1	1	
104D	WOMEN'S TOILET	1ST	FTB	CMU P-1/FT	CMU P-1	CMU P-1	P-1/CMU P-1	ACT-2	0-2	P-1	1	
104A	MEN'S SHOWERS ROOM	1ST	FTB	ENG SGT	EXIST SGT	EXIST SGT	EXIST SGT	ACT-2	0-2	-	3	
104B	MEN'S SHOWER	1ST	FTB	CMU P-1	CMU P-1	CMU P-1	CMU P-1	ACT-2	0-2	-	-	
104C	MEN'S SHOWER	1ST	FTB	FT	FT	FT	FT	ACT-2	0-2	-	-	
104D	MEN'S SHOWER	1ST	FTB	FT	FT	FT	FT	ACT-2	0-2	-	-	
104E	MEN'S SHOWER	1ST	FTB	FT	FT	FT	FT	ACT-2	0-2	-	-	

ROOM FINISH REMARKS

1 PATCH AND REPAIR EXIST'G FLOOR AND BASE TO MATCH EXIST'G AT AREAS OF CONSTRUCTION.

2 STRUCTURAL GLAZED FACING TO BE REPAIRED.

ROOM FINISH LEGEND

KEY	DESCRIPTION
ACT-1	ACETYLENE CEILING TILE - 24" x 24"
ACT-2	VFPI FACED GYPSUM BOARD - 24" x 24"
CMU	CONCRETE MASONRY UNIT
CCFC	CONCRETE
CP	CLAY TILE
E	EMBED STRUCTURE
EX	EXIST'G FINISH
GF	GYPSUM BOARD
TRM	TERRAZZO
F	FLOOR FINISH
FG	FOURED QUARTZ
PT	PORCELAIN TILE
PTB	PORCELAIN TILE BASE
SC	SEALED CONCRETE
SGT	STRUCTURAL GLAZED FACING TILE
VB	VENEER BASE
VCS	VENEER COMPOSITE TILE
WD	WOOD

REFLECTED CEILING PLAN LEGEND

	24" x 24" ACT-1
	WOOD FINISH

DOOR SCHEDULE

DOORING	DOOR SIZE	ELEV.	MATERIAL	GLASS TYPE	HARDWARE SET NO.	FRAME				REMARKS	
						ELEV.	MATERIAL	DEPTH	HEAD		JAMB
101	3'-0" x 7'-0"	D-1	HM	-	BY OWNER	0-1	HM	5 3/4"	2 1/2"	2 1/2"	2 1/2"
102	3'-0" x 7'-0"	D-1	HM	-	BY OWNER	0-1	HM	5 3/4"	2 1/2"	2 1/2"	2 1/2"
104	3'-0" x 7'-0"	D-1	HM	-	BY OWNER	0-1	HM	5 3/4"	2 1/2"	2 1/2"	2 1/2"
105	3'-0" x 7'-0"	D-1	HM	-	BY OWNER	0-1	HM	5 3/4"	2 1/2"	2 1/2"	2 1/2"

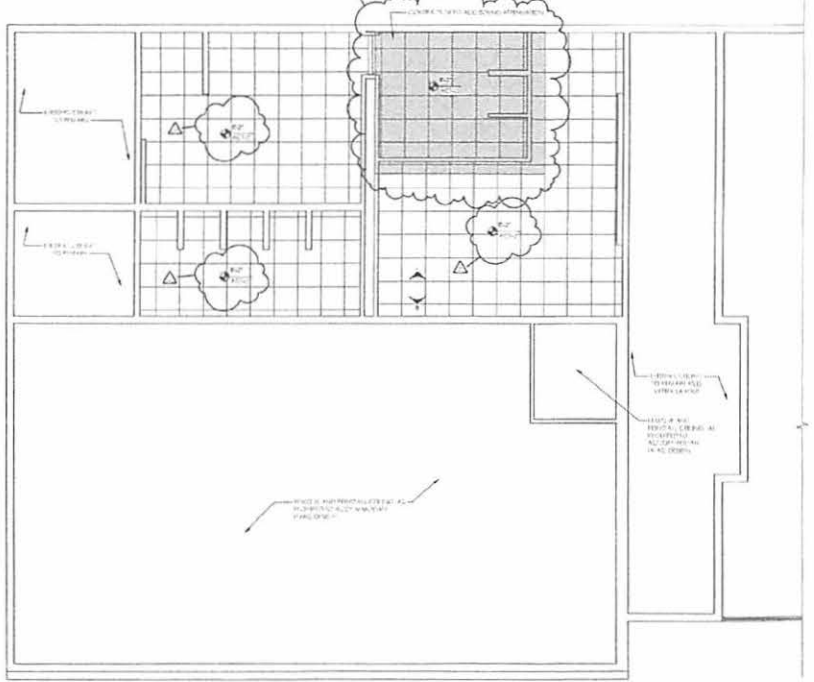
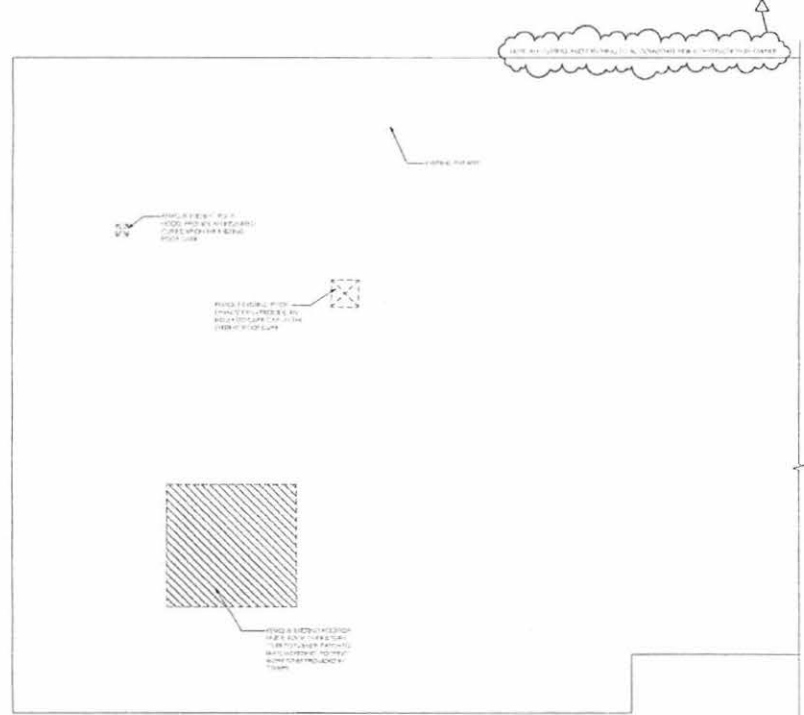
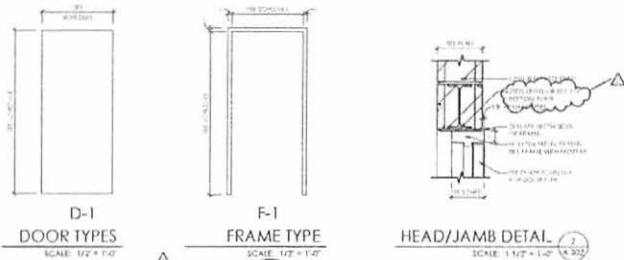

ABACUS ARCHITECTS

REVISIONS:
ADD # 2 - 10/14/2019
ADD # 3 - 10/15/2019

LOCKER ROOM RENOVATIONS
 CITY OF SHEBOYGAN DPW RENOVATION
 2026 NEW JERSEY AVE. SHEBOYGAN, WI 53081
 1338A MONROE AVE. SHEBOYGAN, WI 53081 | P.O. BOX 452 4444 | 232 EAST ST. PALE AVE. MILWAUKEE, WI 53202 | 414.527.4450

DRAWN BY: GAE
CHECKED BY: YSD

A

302

PRGJ. NO. 2019-22

BID SET

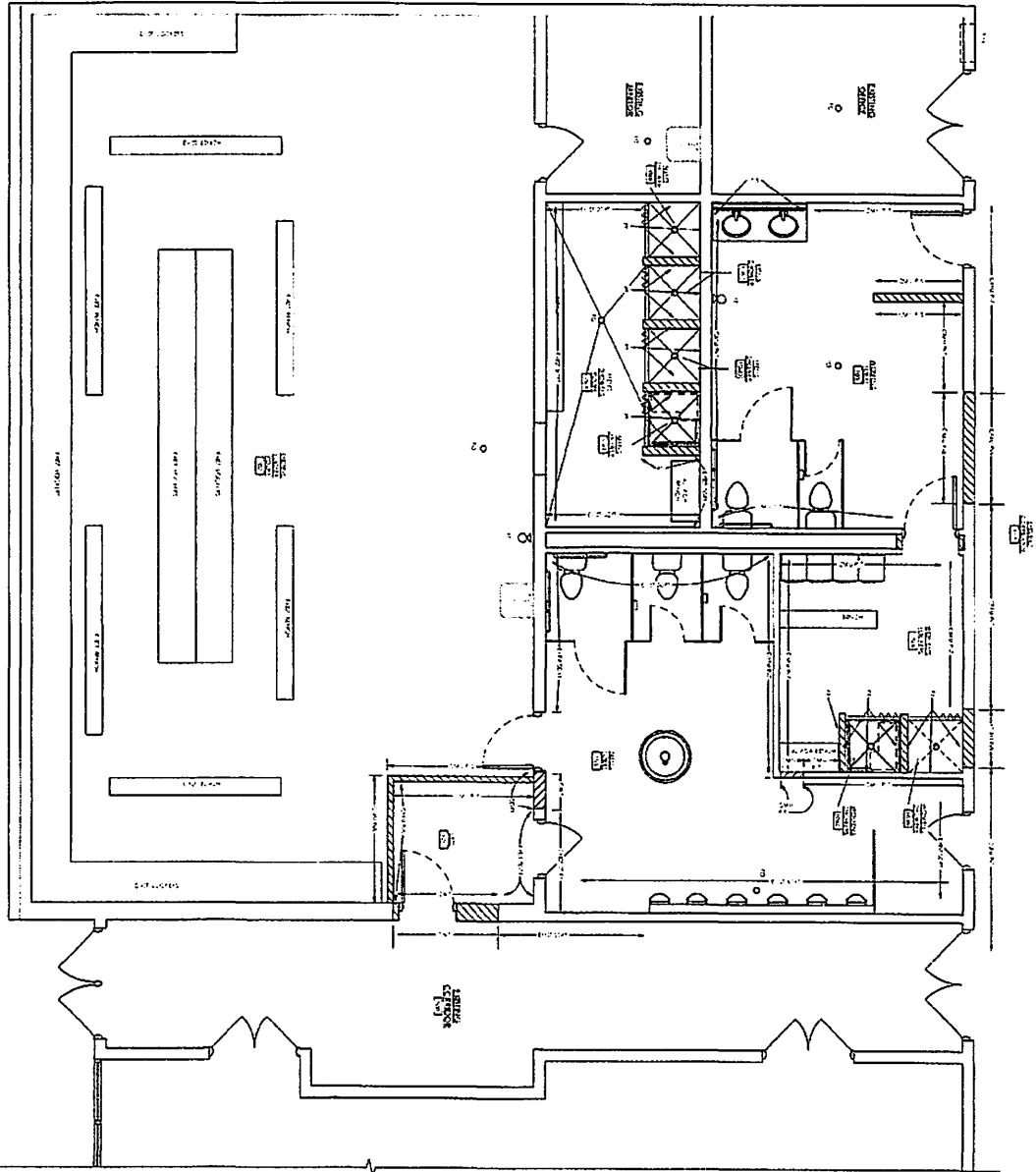

PARTIAL FIRST FLOOR PLAN - FINISH FLOOR
 SCALE: 3/8" = 1'-0"



PROJ. NO. 2019-22

A
304

DRAWN BY: CMH
 CHECKED BY: LEO

9/2/2019
 LOCKER ROOM RENOVATIONS
CITY OF SHEBOYGAN DPW RENOVATION
 2026 NEW JERSEY AVE. SHEBOYGAN, WI 53081
 1135A MICHIGAN AVE. SHEBOYGAN, WI 53081 | P.O. BOX 482-4444 | 228 EAST ST. PAUL, AVE. MILWAUKEE, WI 53202 (414) 837-6430

BID SET

THIS DOCUMENT IS THE PROPERTY OF ABACUS ARCHITECTS. IT IS TO BE USED ONLY FOR THE PROJECT AND SITE SPECIFICALLY IDENTIFIED HEREIN. IT IS NOT TO BE REPRODUCED, COPIED, OR TRANSMITTED IN ANY FORM OR BY ANY MEANS, ELECTRONIC OR MECHANICAL, INCLUDING PHOTOCOPYING, RECORDING, OR BY ANY INFORMATION STORAGE AND RETRIEVAL SYSTEM, WITHOUT THE WRITTEN PERMISSION OF ABACUS ARCHITECTS.

REVISIONS:
 ADD: 4.3.18 HORIZON



GENERAL BUILDING SPECIFICATIONS

**DIVISION 1
GENERAL REQ**

**DIVISION 3
CONCRETE**

**DIVISION 9
FINISHES**

**DIVISION 10
SPECIALTIES**

1.01 - GENERAL
1.01.1 - SUMMARY
1.01.2 - RELATED DIVISIONS

1.02 - QUALITY ASSURANCE
1.02.1 - TESTING

1.03 - MATERIALS
1.03.1 - GENERAL

1.04 - INSTALLATION
1.04.1 - GENERAL

1.05 - PROTECTION
1.05.1 - GENERAL

1.06 - MAINTENANCE
1.06.1 - GENERAL

1.07 - CLEANUP
1.07.1 - GENERAL

1.08 - DEMOLITION
1.08.1 - GENERAL

1.09 - UTILITIES
1.09.1 - GENERAL

1.10 - MISCELLANEOUS
1.10.1 - GENERAL

1.11 - SPECIALTIES
1.11.1 - GENERAL

1.12 - FINISHES
1.12.1 - GENERAL

3.01 - GENERAL
3.01.1 - SUMMARY

3.02 - FORMWORK
3.02.1 - GENERAL

3.03 - REINFORCEMENT
3.03.1 - GENERAL

3.04 - CONCRETE
3.04.1 - GENERAL

3.05 - CURING
3.05.1 - GENERAL

3.06 - PROTECTION
3.06.1 - GENERAL

3.07 - MAINTENANCE
3.07.1 - GENERAL

3.08 - CLEANUP
3.08.1 - GENERAL

3.09 - DEMOLITION
3.09.1 - GENERAL

3.10 - UTILITIES
3.10.1 - GENERAL

3.11 - MISCELLANEOUS
3.11.1 - GENERAL

3.12 - SPECIALTIES
3.12.1 - GENERAL

9.01 - GENERAL
9.01.1 - SUMMARY

9.02 - PAINTS
9.02.1 - GENERAL

9.03 - WALL COVERINGS
9.03.1 - GENERAL

9.04 - CEILING FINISHES
9.04.1 - GENERAL

9.05 - FLOOR FINISHES
9.05.1 - GENERAL

9.06 - GLASS
9.06.1 - GENERAL

9.07 - METALS
9.07.1 - GENERAL

9.08 - WOOD
9.08.1 - GENERAL

9.09 - PLASTER
9.09.1 - GENERAL

9.10 - MASONRY
9.10.1 - GENERAL

9.11 - OTHER FINISHES
9.11.1 - GENERAL

9.12 - SPECIALTIES
9.12.1 - GENERAL

10.01 - GENERAL
10.01.1 - SUMMARY

10.02 - ELEVATORS
10.02.1 - GENERAL

10.03 - ESCALATORS
10.03.1 - GENERAL

10.04 - MECHANICAL
10.04.1 - GENERAL

10.05 - ELECTRICAL
10.05.1 - GENERAL

10.06 - TELEPHONE
10.06.1 - GENERAL

10.07 - SECURITY
10.07.1 - GENERAL

10.08 - SIGNAGE
10.08.1 - GENERAL

10.09 - SPECIALTIES
10.09.1 - GENERAL

10.10 - MISCELLANEOUS
10.10.1 - GENERAL

10.11 - DEMOLITION
10.11.1 - GENERAL

10.12 - UTILITIES
10.12.1 - GENERAL

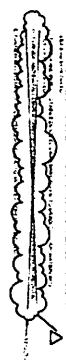

**DIVISION 8
DOORS & WINDOWS**

8.01 - GENERAL
8.01.1 - SUMMARY

8.02 - GLASS
8.02.1 - GENERAL

8.03 - METALS
8.03.1 - GENERAL

8.04 - WOOD
8.04.1 - GENERAL

8.05 - OTHER
8.05.1 - GENERAL

8.06 - SPECIALTIES
8.06.1 - GENERAL

8.07 - MISCELLANEOUS
8.07.1 - GENERAL

9/10/2011
LOCKER ROOM RENOVATIONS
CITY OF SHEBOYGAN DPW RENOVATION
2026 NEW JERSEY AVE. SHEBOYGAN, WI 53081
1135A MICHIGAN AVE. SHEBOYGAN, WI 53081 | 920.452.4448 | 225 EAST ST. PALM AVE. AGENWAIR, WI 53202 | 414.837.6450

REVISIONS:
ADD # 2 10/16/2011

ABACUS
ARCHITECTS

CHAMBERLAIN
C43
CHECKED BY: EJD
A
901
PROJ. NO. 2019-22

BID SET

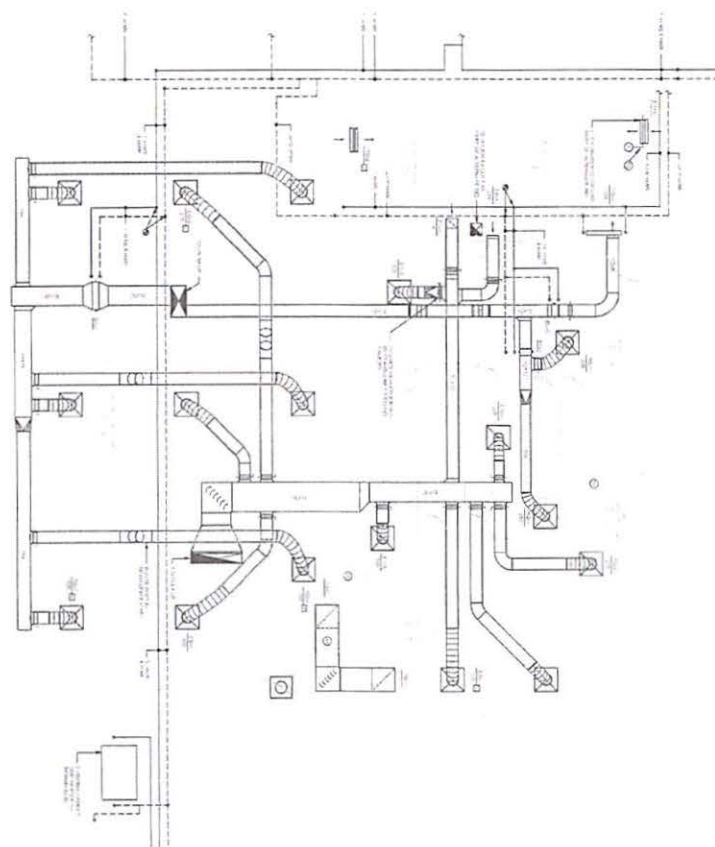

① FIRST FLOOR NEW WORK PLAN - ALTERNATE

ABACUS
ARCHITECTS

REVISIONS:

LOCKER ROOM RENOVATIONS
CITY OF SHEBOYGAN DPW RENOVATION

2026 NEW JERSEY AVE, SHEBOYGAN, WI 53081
1133A MICHOIGAN AVE, SHEBOYGAN, WI 53081 | (920) 432-4444 | 225 EAST ST. PALE AVE., MILWAUKEE, WI 53202 | (414) 537-4450

DSE DYNAMIC CONSULTING ENGINEERS

DCE PROJECT 1802

101
M

PROJECT NO. 2019-22



ZEISE

CONSTRUCTION

Nov-04-19

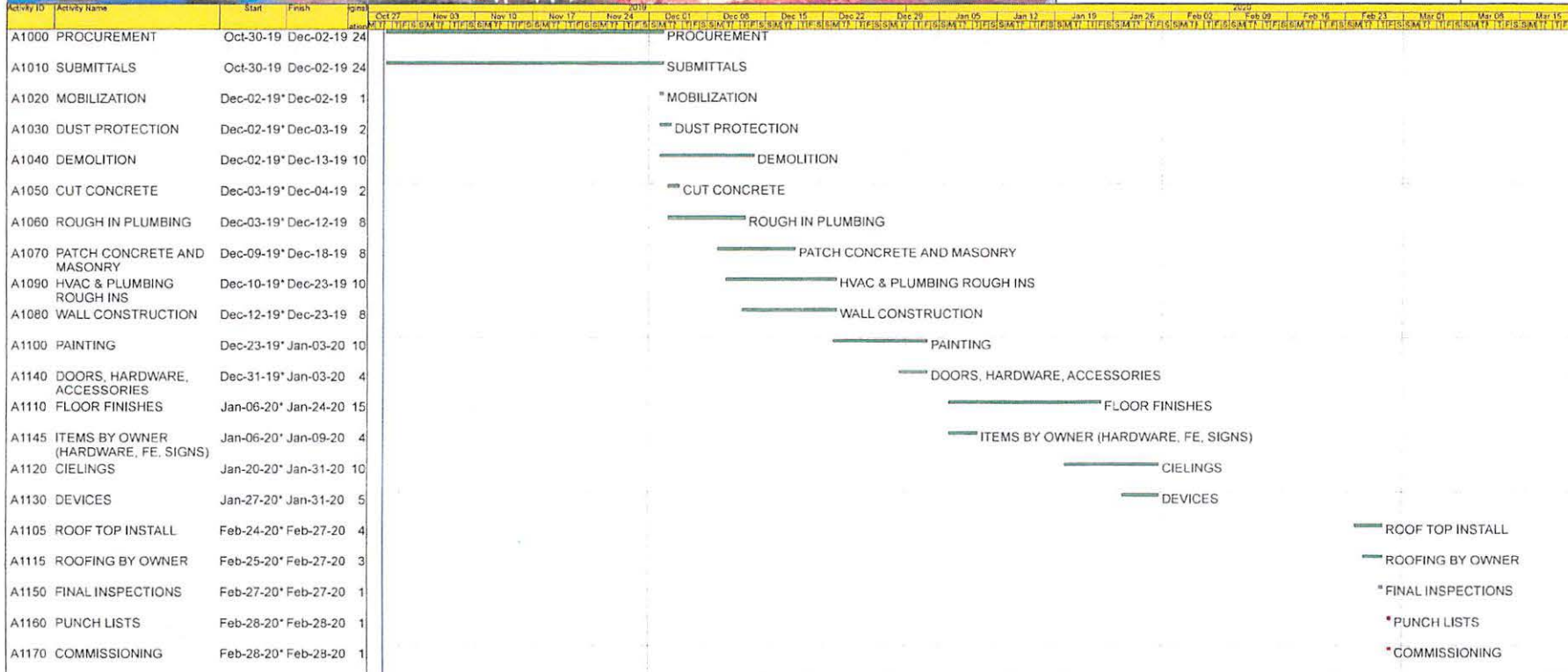

Date	Revision	Checked	Approved
Oct-30-19	PRELIMINARY #1	CMC	CMC
Nov-04-19	PRELIMINARY #2 BASED ON HVAC EQUIPMENT ...	CMC	CMC

SHEBOYGAN DPW LOCKER ROOM RENOVATION

Page 1 of 1

Craig M Cornell, PM



**AGREEMENT
BETWEEN THE CITY OF SHEBOYGAN, WISCONSIN AND
ZEISE CONSTRUCTION, INC.**

**REGARDING REMODELING THE MEN'S AND WOMEN'S BATHROOM FACILITIES
AT THE MUNICIPAL SERVICES BUILDING**

This Agreement ("Agreement") is made and entered into effective this 21st day of November, 2019 (the "Effective Date"), by and between the City of Sheboygan (the "City"), a municipal corporation, and Zeise Construction, Inc. ("Contractor").

WITNESSETH:

WHEREAS, the bathroom facilities at the Municipal Services Building in the City of Sheboygan, located at 2026 New Jersey Ave. are in need of renovation; and

WHEREAS, the City solicited bids for the necessary renovations; and

WHEREAS, Contractor was identified as the lowest responsive and responsible bidder; and

WHEREAS, Contractor is willing and able to complete the renovations under the terms set forth in this Agreement.

NOW, THEREFORE, in consideration of the mutual covenants herein contained, the parties hereto agree as follows:

Article 1. Scope of Services

Contractor shall provide all services and materials necessary to renovate the men's and women's bathroom facilities at the Municipal Services Building in the City of Sheboygan (located at 2026 New Jersey Ave.) (the "Services") pursuant to the Plans and Specifications attached to this Agreement as Exhibit A, as modified by Addendum No. 1 (attached to this Agreement as Exhibit B), Addendum No. 2 (attached to this Agreement as Exhibit C), and Addendum No. 3 (attached to this Agreement as Exhibit D) (collectively the "Plans and Specifications").

Contractor shall be responsible for obtaining any and all applicable City permits and paying any and all applicable permit fees prior to beginning work.

Contractor shall be responsible for furnishing, erecting, and maintaining suitable barricades, warning signs, flashers, fencing, and other protective equipment to properly protect and safeguard its personnel and the public during all phases of the Services.

Contractor shall give notice to the proper authorities in charge of streets, gas and water pipes, electric and other conduits, railroad, poles, catch basins, sewers, and all other property that may be affected by Contractor's operations, at least three (3) business days before beginning operations.

Contractor shall not hinder or interfere with any persons in the protection of such property or with the operations of utilities at any time. Contractor shall protect such utilities from damage and unnecessary exposure. The cost of repairing any damage to utilities shall be the responsibility of Contractor.

Article 2. Standard of Care

Contractor shall be responsible for completion of the Services in a manner consistent with that degree of care and skill ordinarily exercised by members of the same profession currently practicing under similar circumstances (“Standard of Care”). The City shall be the sole judge of the adequacy of Contractor’s work in meeting the Standard of Care; however, the City shall not unreasonably withhold its approval as to the adequacy of Contractor’s performance. Upon notice to Contractor, Contractor will, without additional compensation, correct or replace any and all Services not meeting the Standard of Care.

Article 3. Responsibilities of the City

The City designates Michael Willmas as its designated project manager for purposes of this Agreement.

Article 4. Compensation

The City shall pay Contractor for all fees and expenses in an amount not to exceed Two Hundred Nine Thousand Eight Hundred Thirty Two Dollars (\$209,832).

Invoices may be sent via first class mail postage prepaid or via email. Payment will be remitted to Contractor within forty-five days of receipt of invoice. Contractor shall submit an invoice to the City on a monthly basis and shall be based on the percentage complete of the Services described in Article 1. The invoice shall be sent to:

Michael Willmas
Department of Public Works
City of Sheboygan
2026 New Jersey Ave.
Sheboygan, Wisconsin 53081
michael.willmas@sheboyganwi.gov

Additional services not set forth in Article 1, or changes in the Services must be authorized in writing by the City or its designated project manager prior to such work being performed, or expenses incurred. The City shall not make payment for any unauthorized work or expenses.

The City may withhold payment, in whole or in part, to the extent necessary to protect itself from a loss on account of any of the following:

- Defective work.
- Evidence indicating the probable filing of claims by other parties against Contractor which may adversely affect the City.

- Failure of Contractor to make payments due to subcontractors, material suppliers, or employees.
- Damage to the City or a third party.

The submission of any request for payment shall be deemed a waiver and release by Contractor of all liens and claims with respect to the work and period to which such payment request pertains except as specifically reserved and noted on such request.

Article 5. Appropriation of Funds

Notwithstanding any other provision of this Agreement, if funds for the continued fulfillment of this Agreement by the City are at any time not forthcoming or are insufficient, through failure of any entity, including the City itself, to appropriate funds or otherwise, then the City shall have the right to terminate this Agreement without penalty.

Article 6. Performance and Payment Bond

Contractor shall, within ten (10) days of the approval of this Agreement by the Common Council of the City of Sheboygan, provide the City with a Performance Bond and a Payment Bond in the amount of one hundred percent (100%) of the contract amount.

Failure by Contractor to perform the work in a timely or satisfactory fashion may result in forfeiture of Contractor's Performance Bond.

If the Surety on any bond furnished by Contractor becomes a party to supervision or liquidation, or its right to do business in the State of Wisconsin is terminated, Contractor shall, within thirty (30) calendar days thereafter, substitute another bond or surety, both of which must be acceptable to the City.

Article 7. Schedule

Contractor shall begin the Services as soon as is practicable after this Agreement is approved by the Common Council of the City of Sheboygan and shall continue the prosecution of the Services as quickly as is practicable until the Services are completed. Contractor shall complete the services by March 2020 or within such extra time as may have been allowed by a mutually agreed extension.

The Parties agree that no charges or claims for damages shall be made by Contractor for any delays or hindrances, from any cause whatsoever, during the progress of any portion of the services specified in the Agreement. Such delays or hindrances, if any, may be compensated for by an extension of time for a reasonable period as may be mutually agreed upon between the Parties, it being understood however, that permitting Contractor to proceed to complete any service, or any part of the services / project, after the date to which the time of completion may have been extended shall, in no way operate as a waiver on the part of the City of any of its rights herein.

Article 8. Quality of Materials

All materials used by Contractor shall be new, newest model year, and free from defects. Items which are used, demonstrators, obsolete, seconds, of which have been discontinued are unacceptable without prior written approval by the City.

Article 9. Safety Requirements

Contractor shall be responsible for the safety of employees at all times and shall provide all equipment necessary to insure their safety. Contractor shall ensure the enforcement of all applicable safety rules, regulations, ordinances and laws, whether federal, state, or local. Contractor's Superintendent of Safety shall make daily inspections upon the arrival and leaving of the site at the close of each workday.

Article 10. Open Records

Both parties understand that the City is bound by the Wisconsin Public Records Law and, as such, this contract is subject to that law. Contractor acknowledges that it is obligated to assist the City in retaining and producing records that are subject to Wisconsin Public Records Law, and that the failure to do so shall constitute a material breach of the contract, and that Contractor must defend and hold the City harmless from liability under that law. Except as otherwise authorized, those records shall be maintained for a period of seven (7) years after receipt of final payment under the Agreement.

Article 11. Termination

The City may terminate or suspend performance of this Agreement at the City's prerogative at any time upon written notice to Contractor. Contractor shall terminate or suspend performance of the Services on a schedule acceptable to the City and the City shall pay Contractor for all the Services performed up to the date that written notice is received, plus reasonable termination or suspension expenses. Upon restart, an equitable adjustment shall be made to Contractor's compensation and the schedule of services.

If Contractor defaults or fails to fulfill in a timely and proper manner its obligations pursuant to this Agreement, the City may, seven (7) days after written notice has been delivered to Contractor, and without prejudice to any other remedy it may have, make good such deficiencies and may deduct the cost thereof from the payment then or thereafter due to Contractor. In the alternative the City may, at its option, terminate this Agreement and take possession of the site and of all materials, equipment, tools, and construction equipment and machinery thereon owned by Contractor, and may finish the project by whatever method it may deem expedient. In case the expenses incurred by the City (including payments previously made to Contractor) shall be less than the sum which would have been payable under the Agreement if it had been completed by Contractor, Contractor shall be entitled to receive the difference. However, in case such expense shall exceed the sum which would have been payable under the Agreement, Contractor will be liable and shall pay to the City the amount of said excess. By taking over prosecution of the work, the City does not forfeit the right to recover damages from Contractor or its surety for failure to complete the work in the time specified.

Article 12. Default

If Contractor breaches this Agreement or fails to perform the work in an acceptable manner, it shall be considered in default. Any one or more of the following will be considered a default:

- Failure to begin the work under this Agreement within the time specified.
- Failure to perform the work with sufficient supervision, workers, equipment and materials to insure prompt completion of said work within the time limits allowed.
- Unsuitable performance of the work as determined by City.
- Neglecting or refusing to remove defective materials or failure to perform anew such work as shall have been rejected.
- Discontinuing the prosecution of the work or any part of it.
- Inability to finance the work adequately.
- If, for any other reason, Contractor breaches this Agreement or fails to carry on the work in an acceptable manner.

The City shall send Contractor a written notice of default. If Contractor, within a period of seven (7) days after such notice, fails to remedy the default, then the City shall have full power and authority, without violation of the Agreement, to take the prosecution of the work out of the hands of Contractor, as set forth in this Agreement.

Article 13. Identity of Contractor

Contractor acknowledges that one of the primary reasons for its selection by the City to perform the Services is the qualifications and experience of Contractor. Contractor thus agrees that the Services to be performed pursuant to this Agreement shall be performed by Contractor. Contractor shall not subcontract any part of the Services without the prior written permission of the City. The City's project manager shall have the ability to provide this written permission. The City reserves the right to reject any of the Contractor's personnel or proposed outside professional sub-consultants, and the City reserves the right to request that acceptable replacement personnel be assigned to the project.

Article 14. Independent Contractor Status

During the entire term of this Agreement, Contractor shall be an independent contractor, and in no event shall any of its personnel, agents or sub-contractors be construed to be, or represent themselves to be, employees of the City. Contractor shall be solely responsible for the payment and reporting of all employee and employer taxes, including social security, unemployment, and any other federal, state, or local taxes required to be withheld from employees or payable on behalf of its employees.

Article 15. Indemnification

Contractor shall indemnify, defend, and hold the City—including its Officials, Agents, and Employees—free and harmless from all liability, including, but not limited to, losses, damages, costs, attorney's fees, expenses, causes of action, claims, or judgments resulting from claimed injury, death, damage to property, or loss of use of property or any person or legal entity arising out of or in any way connected with the performance of work or work to be performed under this Agreement.

Contractor shall reimburse the City for any costs, expenses, judgments, and attorney's fees paid or incurred, by or on behalf of the City, its Officials, Agents, or Employees, or paid for on behalf of the City, its Officials, Agents, or Employees by insurance purchased or self-insurance provided by the City arising out of or in any way connected with the performance of work or work to be performed under this Agreement.

Contractor shall further indemnify, defend, and hold harmless the City, its Officials, Agents, and Employees from liability or claims for any injuries to or death of Contractor's employees (or the employees of any authorized subcontractor) arising out of or in any way connected with the work or work to be performed under this Agreement, including protection against any claim of the contractor or subcontractor for any payments under any worker's compensation law or any expenses of or any payments made by any worker's compensation insurance carrier on behalf of said contractor or sub-contractor and the contractor shall indemnify the City for any costs, expenses, judgments, and attorney's fees with respect to any above referenced workers' compensation claims incurred or paid by the City or paid on its behalf or on behalf of its Officials, Agents, or Employees by insurance purchased or self-insurance provided by the City of Sheboygan.

Article 16. Insurance

Contractor shall not commence work under this Agreement until it has obtained all insurance required under this Article. Additionally, Contractor shall not allow any approved subcontractor to commence work on its subcontract until the subcontractor has obtained all insurance required under this Article.

During the performance of any and all Services under this Agreement, Contractor shall maintain the following insurance in full force and effect, and shall provide proof of insurance to the Purchasing Agent listing the City of Sheboygan as an additional insured:

a. **Workers' Compensation Insurance** — Contractor shall acquire and maintain, for the duration of the Agreement, Workers' Compensation Insurance that meets all statutory requirements. In the event this Agreement authorizes any work to be sublet, Contractor shall require any subcontractor to similarly provide Workers' Compensation Insurance in accordance with all statutory requirements.

b. **Commercial General Liability Insurance** — Contractor shall acquire and maintain, for the duration of the Agreement, Commercial General Liability Insurance with a policy limit of at least \$1,000,000 per occurrence and \$2,000,000 in the aggregate.

All insurance must be primary and non-contributory to any insurance or self-insurance carried by the City.

Approval of the insurance by the City shall not relieve or decrease the extent to which Contractor may be held responsible for payment of damages resulting from Contractor's provision of the Services or its operations under this Agreement. If Contractor fails or refuses to procure or maintain the insurance required by these provisions, or fails or refuses to furnish the City the

required proof that the insurance has been procured and is in force and paid for, the City shall have the right at its election to terminate the Agreement.

Article 17. Conflict of Interest

Contractor declares that it has no present interest, nor shall it acquire any interest, direct or indirect, which would conflict with the performance of Services under this Agreement. Contractor agrees that no person having any such interest shall be employed in the performance of this Agreement.

Article 18. Waiver

No failure of either party to enforce a term of this Agreement against the other shall be construed as a waiver of that term, nor shall it in any way affect the party's right to enforce that term. No waiver by any party of any term of this Agreement shall be considered to be a waiver of any other term or breach thereof.

Article 19. Severability

The invalidity, illegality or unenforceability of any provision of this Agreement or the occurrence of any event rendering any portion or provision of this Agreement void shall in no way affect the validity or enforceability of any other portion or provision of this Agreement. Any void provision shall be deemed severed from this Agreement, and the balance of the Agreement shall be construed and enforced as if it did not contain the particular provision to be held void. The parties further agree to amend this Agreement to replace any stricken provision with a valid provision that comes as close as possible to the intent of the stricken provision. The provisions of this Article shall not prevent this entire Agreement from being void should a provision which is of the essence of this Agreement be determined void.

Article 20. Assignment

Neither the City nor Contractor shall assign any rights or duties under this Agreement without the prior written consent of the other party.

Article 21. Third Party Rights

Nothing in this Agreement shall be construed to give any rights or benefits to anyone other than the City and Contractor.

Article 22. Governing Law and Venue

This Agreement shall be governed by the laws of the State of Wisconsin. Venue of any disputes arising under this Agreement shall be in the Sheboygan County Circuit Court, Wisconsin.

Article 23. Non-Discrimination

In connection with the performance of work under this Agreement, Contractor agrees not to discriminate against any employee or applicant for employment because of age, race, religion, color, handicap, sex, physical condition, developmental disability (as defined in Wis. Stat. 51.01(5)), sexual orientation (as defined in Wis. Stat. 111.32(13m)), or national origin. This provision shall include, but not be limited to, the following: employment, upgrading, demotion or transfer, recruitment or recruitment advertising, layoff or termination, rates of pay or other forms of

compensation, and selection for training, including apprenticeship. Contractor further agrees to take affirmative action to ensure equal employment opportunities.

Article 24. Compliance with Laws

In performing the Services under this Agreement, Contractor shall comply with any and all applicable federal, state and local statutes, ordinances, plans, and regulations.

The City reserves the right to cancel this Agreement if Contractor fails to follow the requirements of Wis. Stat. 77.66 and related statutes regarding certification for collection of sales and use tax. The City also reserves the right to cancel this Agreement with any state or federally debarred contractor.

Contractor shall have any and all licenses and permits required to perform the work specified, and shall furnish proof of such licensing authorization and permits upon request.

Article 25. Notices

Any notice required by this Agreement shall be made in writing to the individuals/addresses specified below:

City:

Contractor:

City Clerk	John Gretzinger
City of Sheboygan	Zeise Construction
828 Center Ave.	901 Vanderbraak Street
Sheboygan, Wisconsin 53083	Green Bay, Wisconsin 54302

Nothing contained in this Article shall be construed to restrict the transmission of routine communications between representatives of the City and Contractor.

Article 26. Intent to be Bound

The City and Contractor each binds itself and its successors, executors, administrators, permitted assigns, legal representatives and, in the case of a partnership, its partners to the other party to this Agreement, and to the successors, executors, administrators, permitted assigns, legal representatives and partners of such other party in respect to all provisions of this Agreement.

Article 27. Force Majeure

Neither party shall be in default by reason of any failure in performance of this Agreement in accordance with reasonable control and without fault or negligence on their part. Such causes may include, but are not restricted to, acts of nature or the public enemy, acts of the government in either its sovereign or contractual capacity, fires, floods, epidemics, quarantine restrictions, strikes, freight embargoes, and unusually severe weather. In every case, the failure to perform must be beyond the reasonable control and without the fault or negligence of the party.

Article 28. Integration and Modification

This Agreement, including all Exhibits incorporated by reference, represents the entire and integrated agreement between the City and the Contractor. It supersedes all prior and contemporaneous communications, representations and agreements, whether oral or written, relating to the subject matter of this Agreement. This Agreement may be modified only by a written amendment signed by both parties hereto.

Article 29. Non-Collusion

Contractor is certifying, under penalty of perjury, that to the best of its knowledge and belief:

- a. The price in its bid was arrived at independently, without collusion, consultation, communication, or agreement, for the purpose of restricting competition as to any other matter relating to such prices with any other bidder, or with any other competitor.
- b. No attempt was made to induce any other person, partnership, or corporation to submit or not submit a bid for the purpose of restricting competition.

Article 30. Other Provisions

- a. Material Safety Data Sheet. If any item(s) on an order(s) resulting from this Agreement is a hazardous chemical, as defined under 29 C.F.R. 1910.1200, Contractor shall provide one (1) copy of a Material Safety Data Sheet for each item with the shipped container(s) and one (1) copy with the invoice(s).
- b. Advertising and News Releases. Reference to or use of the City, or any of its departments, officials, or employees, for commercial promotion is prohibited. News releases pertaining to this procurement shall not be made without prior approval of the City. Release of broadcast e-mails pertaining to this procurement shall not be made without prior written authorization of the City.
- c. Foreign Corporation. A foreign corporation (any corporation other than a Wisconsin corporation) which becomes a party to this Agreement is required to conform to all the requirements of Wis. Stat. 180 relating to a foreign corporation, and must possess a certificate of authority from the Wisconsin Department of Financial Institutions, unless the corporation is transacting business in interstate commerce or is otherwise exempt from the requirement of obtaining a certificate of authority.
- d. Neither Party the Drafter. Despite the possibility that one party or its representatives may have prepared the initial draft of this Agreement (or any provision thereof), or played a greater role in the preparation of subsequent drafts, the parties agree that neither of them shall be deemed the drafter of this Agreement.
- e. Authority. Each person executing this Agreement on behalf of a party hereto represents and warrants to the other party: That the execution and delivery of this Agreement has been duly authorized, that the person or persons executing this Agreement have the full power,

authority, and right to do so, and that such execution is sufficient and legally binding on such party to enable this Agreement to be enforceable in accordance with its terms.

IN WITNESS WHEREOF, the parties hereto have caused this Agreement to be executed the day and year first written above.

CITY OF SHEBOYGAN, WISCONSIN

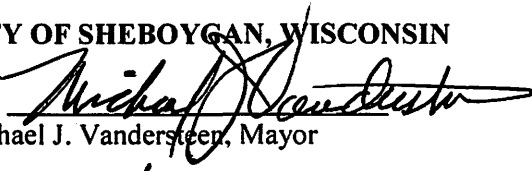
BY: 
Michael J. Vandersteen, Mayor

ATTEST: 
Meredith DeBruin, City Clerk

DATE: 11-25-19

CONTRACTOR

BY: 
Thomas J. Zeise, President

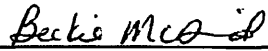
ATTEST: 

DATE: 11-21-19

IX

R. C. No. _____ - 19 - 20. By LICENSING, HEARINGS, AND PUBLIC SAFETY COMMITTEE. November 18, 2019.

Your Committee to whom was referred Gen. Ord. No. 34-19-20 by Alderperson Sorenson amending Gen. Ord. No. 83-11-12, passed by Council on April 4, 2012, in order to update the polling locations for the thirty-one (31) wards relating to Section 38-3 of the Municipal Code regarding wards and aldermanic districts; recommends adopting the Ordinance.

res

_____ Committee

I HEREBY CERTIFY that the foregoing Committee Report was duly accepted and adopted by the Common Council of the City of Sheboygan, Wisconsin, on the _____ day of _____, 20____.

Dated _____ 20____. _____, City Clerk

Approved _____ 20____. _____, Mayor



Gen. Ord. No. 34-19 - 20. By Alderperson Sorenson. November 4, 2019.

AN ORDINANCE amending Gen. Ord. No. 83-11-12, passed by Council on April 4, 2012, in order to update the polling locations for the thirty-one (31) wards relating to Section 38-3 of the Municipal Code regarding wards and aldermanic districts.

THE COMMON COUNCIL OF THE CITY OF SHEBOYGAN DO ORDAIN AS FOLLOWS:

Section 1. Section 38-3 of the Municipal Code entitled, "Wards and Voting Polls", is hereby repealed and recreated to read as follows:

"Section 38-3. Wards and Voting Polls.

The City is hereby divided into thirty-one (31) wards, and boundaries of which are described as follows. All divisions shall be the center of streets unless otherwise prescribed.

(1) FIRST WARD - DISTRICT 1

Beginning at the intersection of North Avenue and North 13th Street, thence North on North 13th Street to Eisner Avenue; thence West on Eisner Avenue to the West right of way line of N 13th Street (North of Eisner Avenue) and the North City limits; thence following along said City limits to the North, West, South, and East to a point on the centerline of North Avenue 134 feet, more or less, West of the West right of way line of North Taylor Drive; thence East on North Avenue to its intersection with North 13th Street and the Point of Beginning.

Voting Poll: Quarryview Center

(2) SECOND WARD - DISTRICT 2

Beginning at the intersection of the shore of Lake Michigan and centerline of Grand Avenue extended, thence West on Grand Avenue, and its extension, to North 6th Street; thence South on North 6th Street to North Avenue; thence West on North Avenue to North 13th Street; thence North on North 13th Street to Eisner Avenue; thence West on Eisner Avenue to the West right of way line of N 13th Street (North of Eisner Avenue) and the North City limits; thence following along said City limits to the North, East, South, and West to its intersection with the shore of Lake Michigan; thence Southeasterly along the shore of Lake Michigan to Grand Avenue extended and the Point of Beginning.

Voting Poll: First Congregational Church

adopt.

(3) THIRD WARD - DISTRICT 2

Beginning at the intersection of the shore of Lake Michigan and the centerline of Grand Avenue extended, thence West on Grand Avenue, and its extension, to North 6th Street; thence South on North 6th Street to North Avenue; thence West on North Avenue to North 15th Street; thence South on North 15th Street to Annie Court; thence East on Annie Court to North 13th Street; thence South on North 13th Street to Bell Avenue; thence East on Bell Avenue to North 3rd Street; thence South on North 3rd Street to Vollrath Boulevard; thence East on Vollrath Boulevard extended to the shore of Lake Michigan; thence Northwesterly along the shore of Lake Michigan to Grand Avenue extended and the Point of Beginning.

Voting Poll: First Congregational Church

(4) FOURTH WARD - DISTRICT 4

Beginning at the intersection of North 15th Street and North Avenue, thence West on North Avenue to North 25th Street; thence South on North 25th Street to Geele Avenue; thence East on Geele Avenue to the West centerline of the Union Pacific Railroad; thence South on said Union Pacific Railroad to Saemann Avenue; thence East on Saemann Avenue to Calumet Drive; thence Northwesterly on Calumet Drive to North 15th Street; thence North on North 15th Street to Heermann Court; thence East on Heermann Court to North 13th Street; thence North on North 13th Street to Annie Court; thence West on Annie Court to North 15th Street; thence North on North 15th Street to North Avenue and the Point of Beginning.

Voting Poll: Quarryview Center

(5) FIFTH WARD - DISTRICT 1

Beginning at the intersection of North Avenue and North 25th Street, thence South on North 25th Street to Geele Avenue; thence West on Geele Avenue to North 36th Street; thence South on North 36th Street to the West City limits; thence North, West, South, and East along the West and North City limits to a point on the centerline of North Avenue 134 feet, more or less, West of the West right of way line of North Taylor Drive; thence East on North Avenue to North 25th Street and the Point of Beginning.

Voting Poll: Evangelical Free Church

(6) SIXTH WARD - DISTRICT 1

Beginning at the intersection of North 25th Street and Geele Avenue, thence West on Geele Avenue to North 36th Street; thence South on North 36th Street to Saemann Avenue; thence East of Saemann Avenue to North 25th Street; thence North on North 25th Street to Geele Avenue and the Point of Beginning.

Voting Poll: Evangelical Free Church

(7) SEVENTH WARD - DISTRICT 4

Beginning at the intersection of the West centerline of the Union Pacific Railroad and Geele Avenue, thence West on Geele Avenue to North 25th Street; thence South on North 25th Street to Cleveland Avenue; thence East on Cleveland Avenue to North 18th Street; thence South on North 18th Street to Saemann Avenue; thence East on Saemann Avenue to said Union Pacific Railroad; thence North on said Union Pacific Railroad to Geele Avenue and the Point of Beginning.

Voting Poll: Evangelical Free Church

(8) EIGHTH WARD - DISTRICT 5

Beginning at the intersection of North 25th Street and Cleveland Avenue, thence East on Cleveland Avenue to North 18th Street; thence South on North 18th Street to Saemann Avenue; thence East on Saemann Avenue to the West centerline of the Union Pacific Railroad; thence South along said Union Pacific Railroad to Superior Avenue; thence West on Superior Avenue to North 22nd Street; thence North on North 22nd Street to Saemann Avenue; thence West on Saemann Avenue to North 25th Street; thence North on North 25th Street to Cleveland Avenue and the Point of Beginning.

Voting Poll: Evangelical Free Church

(9) NINTH WARD - DISTRICT 5

Beginning at the intersection of the West centerline of the Union Pacific Railroad and Saemann Avenue, thence East on Saemann Avenue to North 15th Street; thence South on North 15th Street to Superior Avenue; thence West on Superior Avenue to said Union Pacific Railroad; thence North along said Union Pacific Railroad to Saemann Avenue and the Point of Beginning.

Voting Poll: Evangelical Free Church

(10) TENTH WARD - DISTRICT 4

Beginning at the intersection of Superior Avenue and North 10th Street, thence West on Superior Avenue to North 15th Street; thence North on North 15th Street to Saemann Avenue; thence East on Saemann Avenue to Calumet Drive; thence Northwesterly on Calumet Drive to North 15th Street; thence North on North 15th Street to Heermann Court; thence East on Heermann Court to North 13th Street; thence North on North 13th Street to Bell Avenue; thence East on Bell Avenue to North 9th Street; thence South on North 9th Street to Bluff Avenue; thence West on Bluff Avenue to North 10th Street; thence South on North 10th Street to Superior Avenue and the Point of Beginning.

Voting Poll: Evangelical Free Church

(11) ELEVENTH WARD - DISTRICT 3

Beginning at the intersection of Superior Avenue and North 10th Street, thence North on North 10th Street to Bluff Avenue; thence East on Bluff Avenue to North 9th Street; thence North on North 9th Street to Geele Avenue; thence East on Geele Avenue to North 7th Street; thence South on North 7th Street to Bluff Avenue; thence East on Bluff Avenue to North 5th Street; thence South on North 5th Street to Lincoln Avenue; thence East on Lincoln Avenue to North 3rd Street; thence South on North 3rd Street to Prospect Avenue; thence East on Prospect Avenue to North 2nd Street; thence South on North 2nd Street to Superior Avenue; thence West on Superior Avenue to North 10th Street and the Point of Beginning.

Voting Poll: First Congregational Church

(12) TWELFTH WARD - DISTRICT 2

Beginning at the intersection of the shore of Lake Michigan and Superior Avenue extended, thence West along Superior Avenue, and its extension, to North 2nd street; thence North on North 2nd Street to Prospect Avenue; thence West on Prospect Avenue to North 3rd Street; thence North on North 3rd Street to Lincoln Avenue; thence West on Lincoln Avenue to North 5th Street; thence North on North 5th Street to Bluff Avenue; thence West on Bluff Avenue to North 7th Street; thence North on North 7th Street to Geele Avenue; thence West on Geele Avenue to North 9th Street; thence North on North 9th Street to Bell Avenue; thence East on Bell Avenue to North 3rd Street; thence South on North 3rd Street to Vollrath Boulevard; thence East on Vollrath Boulevard extended to the shore of Lake Michigan; thence Southeasterly and Southwesterly along the shore of Lake Michigan to Superior Avenue extended and the Point of Beginning.

Voting Poll: First Congregational Church

(13) THIRTEENTH WARD - DISTRICT 3

Beginning at the intersection of the shore of Lake Michigan and the centerline of Superior Avenue extended, thence West along Superior Avenue, and its extension, to North 11th Street; thence South on North 11th Street to Michigan Avenue; thence East on Michigan Avenue to North 10th Street; thence South on North 10th Street to Niagara Avenue; thence East on Niagara Avenue to North 8th Street; thence South on North 8th Street to Pennsylvania Avenue; thence East on Pennsylvania Avenue extended to the shore of Lake Michigan; thence Northerly along the shore of Lake Michigan to Superior Avenue extended and the Point of Beginning.

Voting Poll: Mead Library

(14) FOURTEENTH WARD - DISTRICT 7

Beginning at the intersection of Indiana Avenue and South 8th Street, thence West on Indiana Avenue to South 13th Street; thence North on South 13th Street to New Jersey Avenue; thence West on New Jersey Avenue to South 14th Street; thence North on South and North 14th Street to Superior Avenue; thence East on Superior Avenue to North 11th Street; thence South on North 11th Street to Michigan Avenue; thence East on Michigan Avenue to North 10th Street; thence South on North 10th Street to Niagara Avenue; thence East on Niagara Avenue to North 8th Street; thence South on North and South 8th Street to Indiana Avenue and the Point of Beginning.

Voting Poll: Mead Library

(15) FIFTEENTH WARD - DISTRICT 7

Beginning at the intersection of the shore of Lake Michigan and the centerline of Georgia Avenue extended, thence West on Georgia Avenue, and its extension, to South 14th Street; thence North on South 14th Street to New Jersey Avenue; thence East on New Jersey Avenue to South 13th Street; thence South on South 13th Street to Indiana Avenue; thence East on Indiana Avenue to South 8th Street; thence North on South 8th Street to Pennsylvania Avenue; thence East on Pennsylvania Avenue extended to the shore of Lake Michigan; thence Southwesterly along the shore of Lake Michigan to Georgia Avenue extended and the Point of Beginning.

Voting Poll: Senior Activity Center

(16) SIXTEENTH WARD - DISTRICT 5

Beginning at the intersection of Saemann Avenue and North 22nd Street, thence South on North 22nd Street to Superior Avenue; thence East on Superior Avenue to North 17th Street; thence South on North 17th Street to Erie Avenue; thence West on Erie Avenue to North 19th Street and Kohler Memorial Drive; thence West on Kohler Memorial Drive to North 36th Street and the West City limits; thence West, North, East, and South along the West City limits to the intersection of Saemann Avenue and North 36th Street; thence East on Saemann Avenue to North 22nd Street and the Point of Beginning.

Voting Poll: First United Lutheran Church

(17) SEVENTEENTH WARD - DISTRICT 5

Beginning at the intersection of North 18th Street and Erie Avenue Drive, thence West on Erie Avenue to North 19th Street and Kohler Memorial Drive; thence West on Kohler Memorial Drive to North 36th Street and the West City limits; thence South, East, North, and West along said City limits to a point on the West right of way line of South Taylor Drive 1070 feet, more or less, Northwesterly of New Jersey Avenue at the intersection of the current and 2011 City limits; thence South along the 2011 City limits to its intersection with the current City limits; thence South, West, North, and East along the current City limits to South Taylor Drive; thence North on South Taylor Drive to New Jersey Avenue; thence Northeasterly on New Jersey Avenue to Wildwood Avenue; thence Northeasterly on Wildwood Avenue to North 18th Street; thence North on North 18th Street to Erie Avenue and the Point of Beginning.

Voting Poll: First United Lutheran Church

(18) EIGHTEENTH WARD - DISTRICT 6

Beginning at the intersection on North 18th Street and Erie Avenue, thence East on Erie Avenue to North 17th Street; thence North on North 17th Street to Superior Avenue; thence East on Superior Avenue to North 14th Street; thence South on North and South 14th Street to Georgia Avenue; thence West on Georgia Avenue to South 19th Street; thence North on South 19th Street to Indiana Avenue; thence West on Indiana Avenue to the City limits; thence North, West, and South on the City limits to South Taylor Drive; thence North on South Taylor Drive to New Jersey Avenue; thence Northeasterly on New Jersey Avenue to Wildwood Avenue; thence Northeasterly on Wildwood Avenue to North 18th Street; thence North on North 18th Street to Erie Avenue and the Point of Beginning.

Voting Poll: First United Lutheran Church

(19) NINETEENTH WARD - DISTRICT 6

Beginning at the intersection on Indiana Avenue and South 19th Street, thence South on South 19th Street to Georgia Avenue; thence East on Georgia Avenue to the intersection with the centerline of the Union Pacific Railroad; thence Southwesterly along said Union Pacific Railroad to Union Avenue; thence West on Union Avenue to the City limits; thence North, East, South, and West along said City limits to a point on the centerline on Indiana Avenue 150 feet, more or less, West of South 24th Street; thence Northeasterly on Indiana Avenue to South 19th Street and the Point of Beginning.

Voting Poll: Good Shepherd Lutheran Church

(20) TWENTIETH WARD - DISTRICT 8

Beginning at the intersection of the shore of Lake Michigan and Union Avenue extended, thence West on Union Avenue to the centerline of the Union Pacific Railroad; thence Northeasterly along said Union Pacific Railroad to Georgia Avenue; thence East on Georgia Avenue to South 14th Street; thence South on South 14th Street to Broadway; thence East on Broadway to South 12th Street; thence South on South 12th Street to High Avenue; thence East on High Avenue to South 9th Street; thence North on South 9th Street to Broadway; thence East on Broadway extended to the shore of Lake Michigan; thence South along the shore of Lake Michigan to Union Avenue extended and the Point of Beginning.

Voting Poll: Senior Activity Center

(21) TWENTY-FIRST WARD - DISTRICT 7

Beginning at the intersection of the shore of Lake Michigan and Georgia Avenue extended, thence West on Georgia Avenue, and its extension, to South 14th Street; thence South on South 14th Street to Broadway; thence East on Broadway to South 12th Street; thence South on South 12th Street to High Avenue; thence East on High Avenue to South 9th Street; thence North on South 9th Street to Broadway; thence East on Broadway extended to the shore of Lake Michigan; thence North along the shore of Lake Michigan to Georgia Avenue extended and the Point of Beginning.

Voting Poll: Senior Activity Center

(22) TWENTY-SECOND WARD - DISTRICT 9

Beginning at the intersection of the East right of way line of Interstate "43" and the centerline of Washington Avenue/S.T.H. "28", said intersection also being a point on the West City limits, thence North, East, South, and West along the West City limits to Union Avenue; thence East on Union Avenue to Henry Street; thence South on Henry Street to Wilson Avenue; thence West on Wilson Avenue to South 18th Street; thence South on South 18th Street to Washington Avenue/S.T.H. "28"; thence West on Washington Avenue/S.T.H. "28" to the East right of way line of Interstate "43" and the Point of Beginning.

Voting Poll: Good Shepherd Lutheran Church

(23) TWENTY-THIRD WARD - DISTRICT 10

Beginning at the intersection of the East right of way line of Interstate "43" and the centerline of Washington Avenue/S.T.H. "28", said intersection also being a point on the West City limits, thence East on Washington Avenue/S.T.H. "28" to South 18th Street; thence South on South 18th Street to Marvery Road; thence East on Marvery Road to the East right of way line of Pheasant Lane; thence South along the East right of way line of Pheasant Lane to Weeden Creek Road; thence continuing South, East, North, and West along the South City limits to the South right of way line of Weeden Creek Road at South 18th Street; thence West along the South right of way line of Weeden Creek Road to a point 775 feet, more or less, West of Moenning Road; thence South and West along the City limits to the East right of way line of Moenning Road; thence South, West, and East along the City limits to the centerline of South Business Drive; thence South, West, North, and East along the City limits to the East right of way line of Interstate "43" at Racetrack Road; thence North along the East right of way line of Interstate "43" to the centerline of Weeden Creek Road; thence West along the centerline of Weeden Creek Road to the East right of way line of the Union Pacific Railroad; thence Northeasterly along the East right of way line of the Union Pacific Railroad to the East right of way line of Interstate "43"; thence North along the East right of way of Interstate "43" to the centerline of Washington Avenue/S.T.H. "28" and the Point of Beginning, excepting all lands lying within the above described area not under the jurisdiction of the City of Sheboygan.

Voting Poll: Good Shepherd Lutheran Church

(24) TWENTY-FOURTH WARD - DISTRICT 8

Beginning at the intersection of the shore of Lake Michigan and Union Avenue extended, thence West on Union Avenue, and its extension, to Henry Street; thence South on Henry Street to Wilson Avenue; thence East on Wilson Avenue to South 10th Street; thence South on South 10th Street to Washington Avenue; thence East on Washington Avenue to South 9th Street; thence South on South 9th Street to Greenfield Avenue; thence Southeasterly on Greenfield Avenue 165 feet, more or less, to the South City limits; thence South and East along the South City limits to the shore of Lake Michigan; thence North along the shore of Lake Michigan to Union Avenue extended and the Point of Beginning.

Voting Poll: Bethany Reformed

(25) TWENTY-FIFTH WARD - DISTRICT 9

Beginning at the intersection of Wilson Avenue and South 18th Street, thence East on Wilson Avenue to South 10th Street; thence South on South 10th Street to Washington Avenue; thence East on Washington Avenue to South 9th Street; thence South on South 9th Street to Greenfield Avenue; thence West on Greenfield Avenue to South 12th Street; thence South on South 12th Street to Carmen Avenue; thence West on Carmen Avenue to South 18th Street; thence North on South 18th Street to Wilson Avenue and the Point of Beginning.

Voting Poll: Bethany Reformed

(26) TWENTY-SIXTH WARD - DISTRICT 10

Beginning at the intersection of South 9th Street and Greenfield Avenue, thence West on Greenfield Avenue to South 12th Street; thence South on South 12th Street to Carmen Avenue; thence West on Carmen Avenue to South 18th Street; thence South on South 18th Street to the South City limits; thence East, South, West, and North along the South City limits to Greenfield Avenue; thence Northwesterly on Greenfield Avenue to South 9th Street and the Point of Beginning. Also including that parcel of land being South of Panther Avenue and West of South 9th Street known as Indian Mound Park.

Voting Poll: Bethany Reformed

(27) TWENTY-SEVENTH WARD - DISTRICT 5

Beginning at a point on the West right of way line of South Taylor Drive 1070 feet, more or less, Northwesterly of New Jersey Avenue at the intersection of the current and 2011 City limits, thence South, East, and West along the 2011 City limits to its intersection with the current City limits; thence West, North, East, and South along the current City limits to a point on the West right of way line of South Taylor Drive 1070 feet, more or less, Northwesterly of New Jersey Avenue and the Point of Beginning. This ward contains all lands mapped and described in the Certified Survey Map recorded in Volume 27 of Certified Survey Maps on Pages 215-219 as document 2024388 in the Sheboygan County Register of Deeds Office.

Voting Poll: First United Lutheran Church

(28) TWENTY-EIGHTH WARD - DISTRICT 5

Beginning 165 feet, more or less, Northwesterly of the intersection of Wilgus Avenue and North 36th Street at the intersection of the centerline of Wilgus Avenue and the Northerly extension of the West line of Lot 1 of a Certified Survey Map recorded in Volume 7 on Page 236 of Certified Survey Maps in the Sheboygan County Register of Deeds Office, thence South along said West line, and its Northerly extension, 196 feet, more or less, to the Southwest corner of said Lot; thence East along the South line of said Lot, and its extension, 178 feet, more or less, to the East right of way line of North 36th Street; thence North along said East right of way line to the centerline of Wilgus Avenue; thence Northwesterly along said centerline to the intersection with the Northerly extension of said West line and the Point of Beginning.

Voting Poll: First United Lutheran Church

(29) TWENTY-NINTH WARD - DISTRICT 9

Commencing at the intersection of the centerline of Union Avenue and the Northwesterly right of way line of South Taylor Drive, thence West along the centerline of Union Avenue 1234 feet, more or less, to the City limits and Point of Beginning; thence South along the City Limits 331 feet, more or less; thence West 125 feet more or less, to the City Limits; thence North along the City limits 331 feet, more or less, to the centerline of Union Avenue; thence East along the centerline of Union Avenue, and the City Limits, 125 feet, more or less, to the Point of Beginning. This ward contains the parcel described in a personal representative's deed recorded as document 1905817 in the Sheboygan County Register of Deeds Office, and is further referred to as parcel number 59281431081.

Voting Poll: Good Shepherd Lutheran Church

(30) THIRTIETH WARD - DISTRICT 9

Commencing at the intersection of the centerline of Union Avenue and the Northwesterly right of way line of South Taylor Drive, thence West along the centerline of Union Avenue 1032 feet, more or less, to the City limits and Point of Beginning; thence South along the City Limits 330 feet, more or less; thence West 100 feet more or less, to the City Limits; thence North along the City limits 330 feet, more or less, to the centerline of Union Avenue; thence East along the centerline of Union Avenue, and the City Limits, 100 feet, more or less, to the Point of Beginning. This ward contains the parcel described in a warranty deed recorded as document 2012970 in the Sheboygan County Register of Deeds Office, and is further referred to as parcel number 59281431082.

Voting Poll: Good Shepherd Lutheran Church

(31) THIRTY-FIRST WARD - DISTRICT 9

Beginning at the intersection of the centerline of Union Avenue and the Northwesterly right of way line of South Taylor Drive, thence Southwesterly along the Northwesterly right of way line of South Taylor Drive, and the City limits, 247 feet, more or less; thence West 397 feet, more or less, to the City limits; thence North along the City limits 221 feet, more or less, to the centerline of Union Avenue, and the City Limits; thence East along the centerline of Union Avenue, and the City limits, 506 feet, more or less, to the Northwesterly right of way line of South Taylor Drive and the Point of Beginning. This ward contains the parcels described in the warranty deeds recorded as documents 1149902 and 1980404 in the Sheboygan County Register of Deeds Office, and are further referred to as parcel numbers 59281431083 and 59281431084.

Voting Poll: Good Shepherd Lutheran Church

Section 2. All ordinances or parts thereof in conflict with the provisions of this ordinance are hereby repealed to the extent of such conflict, and this ordinance shall be in effect from and after its passage and publication for the purpose of local elections beginning January 1, 2020, and thereafter.

A handwritten signature in black ink, appearing to read "Benjamin", written over a horizontal line.

I HEREBY CERTIFY that the foregoing Ordinance was duly passed by the Common Council of the City of Sheboygan, Wisconsin, on the _____ day of _____, 20____.

Dated _____ 20____. _____, City Clerk

Approved _____ 20____. _____, Mayor

Other Matters

R. O. No. 109 - 19 - 20. By CITY CLERK. November 18, 2019.

Submitting various license applications for the period ending December 31, 2020, June 30, 2020 and June 30, 2021.

City Clerk

BEVERAGE OPERATOR'S LICENSE (NEW) (June 30, 2021)

<u>No.</u>	<u>Name</u>	<u>Address</u>
4688	Allen, William R.	620 Center Avenue, Oostburg
3007	Clark, Debra L.	2709 Main Avenue
3005	Goettl, Francis A.	1817 N. 1 st Street
3009	Khang, May X.	1407 N. 13 th Street
3008	Lewandoske, Amy M.	2411 N. 29 th Street
3010	Lewis, Quiana M.	929 N. 8 th Street Apt. 2
3003	Pribbernow, Grace S.	2123 Woodglen Drive #3D
1288	Sohre, Jayme L.	1718A S. 10 th Street
3006	Thompson, Lisa M.	919 Geele Avenue

"CLASS B" LICENSE (RESERVE) (NEW) (June 30, 2020)

<u>No.</u>	<u>Name</u>	<u>Address</u>
3434	John Michael Kohler Art Preserve	3636 Lower Falls Rd

TAXICAB BUSINESS LICENSE (RENEW) (December 31, 2020)

<u>No.</u>	<u>Name</u>	<u>Address</u>
3023	Yellowcab	2917 N. 15 th Street

TAXICAB DRIVERS LICENSE (RENEW) (December 31, 2020)

<u>No.</u>	<u>Name</u>	<u>Address</u>
9660	Johnson, Charleen M.	1424 S. 9 th Street
9846	Waraich, Celia M.	N6233 Woodland Road
0142	Waraich, Jesse S.	N6233 Woodland Road

AHP5

QUADRICYCLE DRIVER LICENSE (RENEW) (December 31, 2020)

<u>No.</u>	<u>Name</u>	<u>Address</u>
2148	Vannieuwenhoven, Justin	2205 S. 8 th Street

QUADRICYCLE LICENSE (RENEW) (December 31, 2020)

<u>No.</u>	<u>Name</u>	<u>Address</u>
3321	Shebikin' Pedal Tours	2205 S. 8 th Street