

*****ATTACHMENTS*****

CITY OF SHEBOYGAN
TWENTY-THIRD REGULAR COMMON COUNCIL MEETING

Monday, March 4, 2019

ALDERPERSONS PRESENT:

Todd Wolf, Mary Lynne Donohue, Jim Bohren, Ryan Sorenson, Ron Rindfleisch, Markus Savaglio, Dean Dekker, Rose Phillips - 8.

ALDERPERSON ABSENT AND EXCUSED:

Trey Mitchell - 1.

Meeting called to order at 6:00 PM

1. OPENING OF MEETING

1.1 ROLL CALL

1.2 PLEDGE OF ALLEGIANCE - The Pledge was led by Sam Lindow of Boy Scout Troop 801 (Grace Episcopal Church).

1.3 APPROVAL OF MINUTES

MOTION TO APPROVE MINUTES

Motion by Todd Wolf, second by Mary Lynne Donohue.

Final Resolution: Motion Passes

Aye: Todd Wolf, Mary Lynne Donohue, Jim Bohren, Ryan Sorenson, Ron Rindfleisch, Markus Savaglio, Dean Dekker, Rose Phillips - 8.

1.4 RESIGNATION - Alderperson Rosemarie Trester from the City of Sheboygan Common Council - District 4

MOTION TO ACCEPT AND FILE

Motion by Todd Wolf, second by Mary Lynne Donohue.

Final Resolution: Motion Passes

Aye: Todd Wolf, Mary Lynne Donohue, Jim Bohren, Ryan Sorenson, Ron Rindfleisch, Markus Savaglio, Dean Dekker, Rose Phillips - 8.

1.5 MAYOR'S APPOINTMENT - Paul Gottsacker to the Historic Preservation Commission. Lays over.

1.6 MAYOR'S APPOINTMENT - Vicky Schneider to the position of Director of Senior Services. Lays over.

1.7 PRESENTATION - 2019 State of the City Address – City Administrator Darrell Hofland

1.8 PUBLIC FORUM - Limit of five people having five minutes each with comments limited to items on this agenda. No one spoke.

1.9 MAYOR'S ANNOUNCEMENTS - UPCOMING COMMUNITY EVENTS, PROCLAMATIONS, EMPLOYEE RECOGNITIONS

2. HEARING

2.1 Hearing No. 8-18-19 pursuant to a notice published and personal notices sent by the City Clerk, there is a hearing scheduled for this evening for the proposed assessments for water lateral

replacement in North Avenue from N. 15th Street to N. 21st Street.

MOTION TO CLOSE HEARING

Motion by Todd Wolf, second by Mary Lynne Donohue.

Final Resolution: Motion Passes

Aye: Todd Wolf, Mary Lynne Donohue, Jim Bohren, Ryan Sorenson, Ron Rindfleisch, Markus Savaglio, Dean Dekker, Rose Phillips - 8.

3. CONSENT AGENDA

3.1 MOTION TO ACCEPT AND FILE ALL RO'S, ACCEPT AND ADOPT ALL RC'S AND PASS ALL RESOLUTIONS AND ORDINANCES

Resolution: MOTION TO ACCEPT AND FILE ALL RO'S, ACCEPT AND ADOPT ALL RC'S AND PASS ALL RESOLUTIONS AND ORDINANCES

Motion by Todd Wolf, second by Mary Lynne Donohue.

Final Resolution: Motion Passes

Aye: Todd Wolf, Mary Lynne Donohue, Jim Bohren, Ryan Sorenson, Ron Rindfleisch, Markus Savaglio, Dean Dekker, Rose Phillips - 8.

3.2 R. O. No. 223-18-19 by City Clerk submitting various license applications (D'werdenfelser). ACCEPT AND FILE

Resolution: MOTION TO ACCEPT AND FILE

Motion by Todd Wolf, second by Mary Lynne Donohue.

Final Resolution: Motion Passes

Aye: Todd Wolf, Mary Lynne Donohue, Jim Bohren, Ryan Sorenson, Ron Rindfleisch, Markus Savaglio, Dean Dekker, Rose Phillips - 8.

3.3 Res. No. 178-18-19 by Alderperson Rindfleisch confirming the exercise of police power in making an assessment for those benefited properties against which assessments are proposed for the replacement of lead and/or galvanized iron water laterals in North Avenue from N. 15th Street to N. 21st Street. PASS RESOLUTION

Resolution: MOTION TO PASS RESOLUTION

Motion by Todd Wolf, second by Mary Lynne Donohue.

Final Resolution: Motion Passes

Aye: Todd Wolf, Mary Lynne Donohue, Jim Bohren, Ryan Sorenson, Ron Rindfleisch, Markus Savaglio, Dean Dekker, Rose Phillips - 8.

3.4 R. C. No. 256-18-19 by Licensing, Hearings, and Public Safety Committee to whom was referred R. O. No. 204-18-19 by City Clerk submitting various license applications, recommends denying Taxicab Driver License application No. 2008 (Bethany B. Garcia) based upon her recent record of violations related to the licensed activity and her failure to cooperate with the committee. ACCEPT AND FILE

Resolution: MOTION TO ACCEPT AND FILE

Motion by Todd Wolf, second by Mary Lynne Donohue.

Final Resolution: Motion Passes

Aye: Todd Wolf, Mary Lynne Donohue, Jim Bohren, Ryan Sorenson, Ron Rindfleisch, Markus Savaglio, Dean Dekker, Rose Phillips - 8.

3.5 R. C. No. 257-18-19 by Finance and Personnel Committee to whom was referred R. O. No. 220-18-19 by City Administrator submitting the City Of Sheboygan 2019 Long Term Financial Plan to the Common Council; recommends to file the document. ACCEPT AND FILE

Resolution: MOTION TO ACCEPT AND FILE

Motion by Todd Wolf, second by Mary Lynne Donohue.

Final Resolution: Motion Passes

Aye: Todd Wolf, Mary Lynne Donohue, Jim Bohren, Ryan Sorenson, Ron Rindfleisch, Markus Savaglio, Dean Dekker, Rose Phillips - 8.

3.6 R. C. No. 258-18-19 by Licensing, Hearings, and Public Safety Committee to whom was referred R. O. No. 221-18-19 by Chief of Police submitting the annual report of the Sheboygan Police Department for the year 2018; recommends filing the document. ACCEPT AND FILE

Resolution: MOTION TO ACCEPT AND FILE

Motion by Todd Wolf, second by Mary Lynne Donohue.

Final Resolution: Motion Passes

Aye: Todd Wolf, Mary Lynne Donohue, Jim Bohren, Ryan Sorenson, Ron Rindfleisch, Markus Savaglio, Dean Dekker, Rose Phillips - 8.

3.7 R. C. No. 259-18-19 by Licensing, Hearings, and Public Safety Committee to whom was referred, pursuant to R. O. No. 222-18-19 by City Clerk submitting various license applications; recommends that the following licenses be granted with various caveats. ACCEPT AND FILE

Resolution: MOTION TO ACCEPT AND FILE

Motion by Todd Wolf, second by Mary Lynne Donohue.

Final Resolution: Motion Passes

Aye: Todd Wolf, Mary Lynne Donohue, Jim Bohren, Ryan Sorenson, Ron Rindfleisch, Markus Savaglio, Dean Dekker, Rose Phillips - 8.

3.8 R. C. No. 260-18-19 by Public Works Committee to whom was referred Res. No. 175-18-19 by Alderpersons Wolf and Sorenson authorizing the appropriate City officials to enter into a contract for the Mead Public Library Plaza renovation project; recommends approving the Resolution. ACCEPT AND ADOPT AND PASS RESOLUTION

Resolution: MOTION TO ACCEPT AND ADOPT AND PASS RESOLUTION

Motion by Todd Wolf, second by Mary Lynne Donohue.

Final Resolution: Motion Passes

Aye: Todd Wolf, Mary Lynne Donohue, Jim Bohren, Ryan Sorenson, Ron Rindfleisch, Markus Savaglio, Dean Dekker, Rose Phillips - 8.

3.9 R. C. No. 264-18-19 by Licensing, Hearings, and Public Safety Committee to whom was referred Gen. Ord. No. 45-18-19 by Alderpersons Donohue, Dekker, Sorenson and Wolf amending Section 2-138 of the Municipal Code to provide that remote attendance would be included in the quorum count; recommends approving the Ordinance. ACCEPT AND ADOPT AND PASS ORDINANCE

Resolution: MOTION TO ACCEPT AND ADOPT AND PASS ORDINANCE

Motion by Todd Wolf, second by Mary Lynne Donohue.

Final Resolution: Motion Passes

Aye: Todd Wolf, Mary Lynne Donohue, Jim Bohren, Ryan Sorenson, Ron Rindfleisch, Markus Savaglio, Dean Dekker, Rose Phillips - 8.

4. REPORTS OF OFFICERS

4.1 R. O. No. 224-18-19 by City Clerk submitting a communication from Prohibition Bistro (Avni and Harry Latifi) requesting an encroachment into portions of Lot 1 Promenade, South Pier for the purpose of expanding the outdoor patio area. REFER TO CITY PLAN COMMISSION

4.2 R. O. No. 225-18-19 by City Clerk submitting a claim from Zachory T. Felsing for alleged damages to his vehicle when it was struck by a garbage truck. REFER TO FINANCE AND PERSONNEL COMMITTEE

5. RESOLUTIONS

5.1 Res. No. 179-18-19 by Alderpersons Wolf and Donohue authorizing the appropriate City officials to sign the January 1, 2018 - December 31, 2020 Contract between the City of Sheboygan and International Association of Firefighters Local 483. SUSPEND AND PASS RESOLUTION

MOTION TO SUSPEND AND PASS RESOLUTION

Motion by Todd Wolf, second by Mary Lynne Donohue.

Final Resolution: Motion Passes

Aye: Todd Wolf, Mary Lynne Donohue, Jim Bohren, Ryan Sorenson, Ron Rindfleisch, Markus Savaglio, Dean Dekker, Rose Phillips - 8.

5.2 Res. No. 180-18-19 by Alderpersons Rindfleisch and Bohren authorizing the Purchasing Agent to issue a purchase order for the purchase of the 20 BCycle Bike Share Program and related software for use in the downtown and the waterfront areas. REFER TO FINANCE AND PERSONNEL COMMITTEE

5.3 Res. No. 181-18-19 by Alderpersons Rindfleisch and Bohren authorizing the Senior Activity Center of Sheboygan to accept a donation of an automated external defibrillator (AED) to be placed at the Senior Activity Center. REFER TO FINANCE AND PERSONNEL COMMITTEE

5.4 Res. No. 182-18-19 by Alderpersons Rindfleisch and Bohren authorizing the appropriate City officials to execute the PILOT Agreement between the City of Sheboygan, Wasserman Redevelopment, LLC, and the Housing Authority of the City of Sheboygan, Wisconsin, with regard to the Housing Authority rental project located at 611 North Water Street. REFER TO FINANCE AND PERSONNEL COMMITTEE

5.5 Res. No. 183-18-19 by Alderpersons Wolf and Donohue dissolving the Sustainable Sheboygan Task Force. REFER TO LICENSING, HEARINGS, AND PUBLIC SAFETY COMMITTEE

5.6 Res. No. 184-18-19 by Alderpersons Wolf and Donohue changing the starting time of the organizational meeting of the new council for council year 2019-20. REFER TO LICENSING, HEARINGS, AND PUBLIC SAFETY COMMITTEE

5.7 Res. No. 185-18-19 by Alderpersons Wolf and Sorenson authorizing the appropriate City officials to enter into a contract for the 2019 Sidewalk Program project. REFER TO PUBLIC WORKS COMMITTEE

5.8 Res. No. 186-18-19 by Alderperson Wolf authorizing the Mayor to execute the amended 2019 General Contract between Sheboygan County Health & Human Services Department and Shoreline Metro regarding transportation for elderly and disabled individuals. REFER TO TRANSIT COMMISSION

6. REPORT OF COMMITTEES

6.1 R. C. No. 261-18-19 by Public Works Committee to whom was referred Res. No. 176-18-19 by Alderpersons Wolf and Sorenson authorizing a transfer of appropriations in the 2019 Budget (traffic signal upgrade); recommends approving the Resolution. ACCEPT AND ADOPT AND PASS RESOLUTION

MOTION TO ACCEPT AND ADOPT AND PASS RESOLUTION

Motion by Todd Wolf, second by Ryan Sorenson.

Final Resolution: Motion Passes

Aye: Todd Wolf, Mary Lynne Donohue, Jim Bohren, Ryan Sorenson, Ron Rindfleisch, Markus Savaglio, Dean Dekker, Rose Phillips - 8.

6.2 R. C. No. 262-18-19 by Finance and Personnel Committee to whom was referred DIRECT

REFERRAL Res. No. 177-18-19 by Alderpersons Rindfleisch and Bohren authorizing entering into a letter agreement with Graef-USA, Inc. for professional planning services; recommends approving the Resolution with updated contracts. ACCEPT AND ADOPT AND PASS RESOLUTION

MOTION TO ACCEPT AND ADOPT AND PASS RESOLUTION

Motion by Ron Rindfleisch, second by Jim Bohren.

Final Resolution: Motion Passes

Aye: Todd Wolf, Mary Lynne Donohue, Jim Bohren, Ryan Sorenson, Ron Rindfleisch, Markus Savaglio, Dean Dekker, Rose Phillips - 8.

6.3 R. C. No. 265-18-19 by Finance and Personnel Committee to whom was referred Gen. Ord. No. 42-18-19 by Alderpersons Rindfleisch and Bohren amending Section 82-33 of the Sheboygan Municipal Code so as to modify the City Administrator's Department Table of Organization; recommends approving the Ordinance with updated job description. ACCEPT AND ADOPT AND PASS ORDINANCE

MOTION TO ACCEPT AND ADOPT AND PASS ORDINANCE with updated job description provided to the council this evening in writing; and to request Clerk attach the updated job description to the Ordinance.

Motion by Ron Rindfleisch, second by Jim Bohren.

Final Resolution: Motion Passes

Aye: Todd Wolf, Mary Lynne Donohue, Jim Bohren, Ryan Sorenson, Ron Rindfleisch, Markus Savaglio, Dean Dekker, Rose Phillips - 8.

6.4 R. C. No. 266-18-19 by Finance and Personnel Committee to whom was referred Gen. Ord. No. 43-18-19 by Alderpersons Rindfleisch and Bohren amending Section 82-33 of the Sheboygan Municipal Code so as to modify the Senior Activity Center Table of Organization; recommends approving the Ordinance with updated job description. ACCEPT AND ADOPT AND PASS ORDINANCE

MOTION TO ACCEPT AND ADOPT AND PASS ORDINANCE with updated job description provided to the council this evening in writing; and to request Clerk attach the updated job description to the Ordinance.

Motion by Ron Rindfleisch, second by Jim Bohren.

Final Resolution: Motion Passes

Aye: Todd Wolf, Mary Lynne Donohue, Jim Bohren, Ryan Sorenson, Ron Rindfleisch, Markus Savaglio, Dean Dekker, Rose Phillips - 8.

6.5 R. C. No. 263-18-19 by Finance and Personnel Committee to whom was referred Gen. Ord. No. 44-18-19 by Alderpersons Rindfleisch and Bohren amending Section 82-33 of the Sheboygan Municipal Code so as to modify the City Development Department/Building Inspection Division Table of Organization; recommends approving the Ordinance. ACCEPT AND ADOPT AND PASS ORDINANCE

MOTION TO ACCEPT AND ADOPT AND PASS ORDINANCE

Motion by Ron Rindfleisch, second by Jim Bohren.

Final Resolution: Motion Passes

Aye: Todd Wolf, Mary Lynne Donohue, Jim Bohren, Ryan Sorenson, Ron Rindfleisch, Markus Savaglio, Dean Dekker, Rose Phillips - 8.

6.6 R. C. No. 267-18-19 by Finance and Personnel Committee to whom was referred Gen. Ord. No. 46-18-19 by Alderpersons Rindfleisch and Bohren amending Section 82-33 of the Sheboygan Municipal Code so as to modify the Department of Finance Table of Organization; recommends approving the Ordinance with updated job description. ACCEPT AND ADOPT AND PASS ORDINANCE

MOTION TO ACCEPT AND ADOPT AND PASS ORDINANCE

Motion by Ron Rindfleisch, second by Jim Bohren.

Final Resolution: Motion Passes

Aye: Todd Wolf, Mary Lynne Donohue, Jim Bohren, Ryan Sorenson, Ron Rindfleisch, Markus Savaglio, Dean Dekker, Rose Phillips - 8.

7. GENERAL ORDINANCE

7.1 Gen. Ord. No. 47-18-19 by Alderperson Phillips granting Prohibition Bistro, its successors and assigns, the privilege of encroaching upon described portions of Lot 1 Promenade, South Pier located at 668 South Pier Drive in the City of Sheboygan for the purpose of expanding the outdoor patio area. REFER TO CITY PLAN COMMISSION

8. OTHER MATTERS RECIEVED AFTER THE AGENDA WAS PUBLISHED

8.1 R. O. No. 226-18-19 by City Clerk submitting various license applications. REFER TO LICENSING, HEARINGS, AND PUBLIC SAFETY COMMITTEE

9. CLOSED SESSION

9.1 Motion to convene in closed session under the exemption contained in Sec. 19.85(1)(e), Wis. Stats., where competitive or bargaining reasons require a closed session related to possible purchase of land in SouthPointe Enterprise Campus.

MOTION TO CONVENE IN CLOSED SESSION

Motion by Todd Wolf, second by Mary Lynne Donohue.

Final Resolution: Motion Passes

Aye: Todd Wolf, Mary Lynne Donohue, Jim Bohren, Ryan Sorenson, Ron Rindfleisch, Markus Savaglio, Dean Dekker, Rose Phillips - 8.

10. ADJOURN MEETING

10.1 Motion to Adjourn

MOTION TO ADJOURN at 6:51 PM

Motion by Todd Wolf, second by Mary Lynne Donohue.

Final Resolution: Motion Passes

Aye: Todd Wolf, Mary Lynne Donohue, Jim Bohren, Ryan Sorenson, Ron Rindfleisch, Markus Savaglio, Dean Dekker, Rose Phillips - 8.

Generated by City Clerk Meredith DeBruin on Tuesday, March 5, 2019

Betty A. Rose-Ackley
1116 Lincoln Avenue
Sheboygan, WI 53081

MAR 4 '19 PM 2:00

Ms. Meredith DeBruin
City Clerk – City of Sheboygan
828 Center Avenue
Sheboygan, WI 53081

March 4, 2019

RE: District 4 Common Council Position

Dear Ms. DeBruin,

Please accept this letter as a request to be considered for the position of common council representative for district 4. I was saddened to see the posting on Nextdoor that Rosemarie Trester was leaving her post on the common council for the remainder of her term. One thing I often looked forward to was her quarterly newsletter. I feel that she has left enormous shoes to fill.

My husband, children and I all feel a strong connection to the City of Sheboygan. My husband Ted is a Sheboygan native. He served in the U.S. Army for 24 years and retired in good standing. Ted's father, Michael Ackley, served for 31 years with the Sheboygan Police Department. Ted's mother, Norma Ackley, was a beloved German language teacher with the Sheboygan Area School District, and she ran for mayor many years ago. We chose to raise our four children in Sheboygan, and have lived in the city since 2009.

Our family has lived on Lincoln Avenue since August of 2015. As a wife and mother, my main concern has always been that my children grow up in a wholesome environment and a safe community. One thing I noticed was that neighbors did not talk to each other often. Everyone was in their private oasis within their property boundaries. My family rented a home on the south side of Sheboygan from August 2009 until August of 2015. When we lived on the south side, our neighbors on the block often organized picnics and get-togethers as a way to keep our micro-community connected. When moving to Lincoln Avenue, I found myself attempting to get to know our neighbors and reaching out to form friendships. During the three years we have lived here, my husband and I have tried to ensure we know the people in our immediate neighborhood. When I see people walking by, I always make an effort to smile, say hello and wish them a good day. These are qualities of the neighborhoods I grew up in when I was a child. In today's technologically connected world, often we become so engrossed in our own lives, it can be challenging to focus on others. However, to ensure we have a safe and healthy neighborhood, we must reach beyond our property lines and at a minimum, be available to help our neighbors.

I am currently attending school at Lakeshore Technical College (LTC) to complete general education requirements. I have been accepted to UW-Green Bay and will begin taking courses there in the fall semester of 2019. While at UW-Green Bay, I will be working toward a bachelor's degree in Psychology. Mental health is a subject matter that has been stigmatized for far too long. There is a tremendous need within the research sector of the mental health field and will be my future goal once I have completed a Ph.D. program. As I continue my educational journey, I hope to show my children that no matter how old you are, if you have a will to do something, you will find a way to get it done. I have maintained a 4.0 GPA, achieved the Dean's List

twice, and have joined Phi Theta Kappa Honor Society as of the fall of 2018. In addition to my academic achievements, I chose to self nominate in September 2018 for the position of Vice President of the Student Government Association at LTC. I have thoroughly enjoyed helping my fellow students and leading by example. I feel that there is always a way to serve others.

My husband Ted is a volunteer firefighter with the Town of Sheboygan Fire Department. He works at Piggly Wiggly Midwest as a Transportation Supervisor. I telecommute and work part-time as a Market Research Analyst in addition to my studies and caring for our three children still living at home, who range in age from 7 to 15. My eldest son is a cryptology technician with the U.S. Naval Reserves and a full-time college student at UW-Whitewater, so he is no longer living in our home.

The SGA experience has led me to believe that working for my community, and my neighborhood, would be emotionally rewarding as well as a way to give back to the city in which I live. I thank you in advance for your time and consideration with this matter. My cell phone number is (920) 226-4790, and my email address is autumnalraven@gmail.com should you have any questions or comments.

Warmest Regards,



Betty A. Rose-Ackley

John A. Holzwart
1225 Heermann Ct
Sheboygan, WI 53081
February 27th, 2019

To whom it may concern:

Please consider this letter a formal declaration of my interest in Aldermanic position available in Sheboygan's 4th district.

My name is John Holzwart, son of John Holzwart, grandson of John Holzwart and great Grandson of John Holzwart who came to Sheboygan as a German Russian immigrant to flee the Bolsheviks in Reinwald, Russia. My family has a long history here and I'm proud to call this place my home.

Although I've lived here my entire life I have had opportunities to explore many other areas and aspects of this beautiful country, and yet I always look forward to returning to my hometown.

As you can see from my resume, I graduated from North High School in 1993. After jumping right into college level classes with a desire to become an art teacher I had a change of heart. I decided to start working in a local factory and chase the American dream. At 22 years old I bought my first house, of which I still live in today.

In 2007 when they closed the doors to the factory I decided I would try my hand at being self-employed. I transitioned into working with a partner and our business, Moonwise Herbs, was born. After many years of rewarding work our partnership ended in 2015.

At that point I formed my own business, Plant Based Services, and continued to do what I had been doing previously. This time I was solo and had the freedom to travel even more than I had been. I began getting hired as a historic demonstrator in 2007 and so the search for more events began. Annually I reach out to county and state fairs that are looking for demonstrators at their events. I've been hired as the broom maker at such large events as the Los Angeles County Fair, Erie County Fair (Buffalo, NY), Oklahoma State Fair, South Carolina State Fair as well as many other smaller fairs in MN, NY, VA & WI

My marketing and networking has paid off over the years, however, I am ready to travel less, shift my business focus to online sales, and focus more on local initiatives and community projects. The winter is when I start signing contracts with fairs and at this point I have only accepted a couple. The timing of this opportunity to serve as a representative of my city is perfect. Thank you for considering me for this position and please let me know if you have any questions.

Sincerely,

John A. Holzwart

John A. Holzwart

Artist Broom Maker

CONTACT

Email: plantbased@att.net

Phone: (920)457-9290

Address: 1225 Heermann Ct, Sheboygan,
WI 53081

SKILLS

Creative
Adaptable
Collaborative
Strong Communication
Resourceful
Critical Thinking
Team Building
Leadership

RESUME OBJECTIVE

I have been self-employed since 2007 and currently have a flexible schedule that involves some travel. I am looking to reduce my travel time and shift my focus to local opportunities, online marketing and distributions of the products or services that I provide. I hope to combine my love for Sheboygan, my interpersonal skills, and my desire to serve my community by representing Sheboygan's 4th district on the Common Council.

Education and Training

1993 North High School - Sheboygan, WI
1993 College Level Art Classes (Drawing, Sculpture, Pottery) - U.W. Sheboygan, WI
1998 Woodcarving Independent Study - Mentored by Richard Anderson
2004 Wilderness Survival Series - Maywood Environmental Center, Sheboygan, WI
2004 Cordwood Masonry - Weekend Workshop w/Rob Roy - Elkhart Lake, WI
2005 Continental Cordwood Conference - Merrill, WI
2005 Broom Making Workshop - Milwaukee, WI
2005 Broom Making (Advanced Studies with Instructor) - Rhinelander, WI
2006 Wild Edibles Symposium - Beaver Creek, WI
2006 Organic Apple Production w/Michael Phillips - Lacrosse, WI
2006 Non Violent Communication (Introduction) - Madison, WI
2007 Non Violent Communication - Weekend Intensive - Madison, WI
2007 New Warrior Training Adventure - WI Mankind Project
2010 Permaculture Design Certificate-Midwest Permaculture, Stelle, Ill
2011 Educational Delegation to Cuba. w/Global Exchange.
2011 Growing Mushrooms for Profit - LaCrosse, WI
2011 Natural Bee Keeping Certificate - Milwaukee, WI
2015 Non Violent Communication – 4 Day Intensive - Chicago, IL

Work History

1996 - 2007 Masland/Lear Corp/IAC -Sheboygan, WI

Title: Production worker

Duties include: Running various machines, changing over tooling in said machines, forklift driving, time keeping, paperwork, etc.

2004 - 2015 Moonwise Herbs - Sheboygan, WI

Title: Partner/ Lead Forager

Duties include: Foraging edible and medicinal wild plants, product making, teaching classes, vending wares at events, managing interns and apprentices, hired demonstrator

2013 - 2016 Mankind Project of Wisconsin - Milwaukee, WI

Title: Training Director

Duties include: Planning men's weekends, space rental, public outreach, enrollment, financial negotiations with participants, delegate work to support staff, report to board of directors

2015 - Present Plant Based Services, LLC - Sheboygan, WI

Title: Owner

Duties include: Foraging edible and medicinal wild plants, product making, honey bee removal and relocations, teaching classes, vending wares at events, hired demonstrator



March 15, 2019

HONORABLE MEMBERS OF THE COMMON COUNCIL:

I hereby submit the following appointment for your consideration:

The newly elected Alderperson of District 4 to be considered for appointment to the Licensing, Hearings, and Public Safety Committee to fill the unexpired term of Rosemarie Trester whose term expires 4/15/2019.

MICHAEL J. VANDERSTEEN, MAYOR

OFFICE OF MAYOR

CITY HALL
828 CENTER AVE., SUITE 301
SHEBOYGAN, WI
53081-4495

920/459-3317
FAX 920/459-0256



February 28, 2019

HONORABLE MEMBERS OF THE COMMON COUNCIL:

I hereby submit the following appointment for your consideration:

Paul Gottsacker to be considered for appointment to the Historic Preservation Commission to fill the unexpired term of Adam Cain whose term expires 4/20/2020.

MICHAEL J. VANDERSTEEN, MAYOR

Approved

OFFICE OF MAYOR
CITY HALL
828 CENTER AVE., SUITE 301
SHEBOYGAN, WI
53081-4495

920/459-3317
FAX 920/459-0256



February 28, 2019

HONORABLE MEMBERS OF THE COMMON COUNCIL:

I hereby submit the following appointment for your consideration:

Vicky Schneider to be considered for appointment to the position of Director of Senior Services.

MICHAEL J. VANDERSTEEN, MAYOR

Approved

OFFICE OF MAYOR

CITY HALL
828 CENTER AVE., SUITE 301
SHEBOYGAN, WI
53081-4495

920/459-3317
FAX 920/459-0256

II

R. O. No. _____ - 18 - 19. By BOARD OF CONTRACTORS EXAMINERS.
March 18, 2019

Attached hereto we are submitting application for Building Contractor License already GRANTED:

6381 Tyler S Holschbach
N2911 State Hwy 32
Oostburg, WI 53070-2134

Carpenter Contractor

BOARD OF CONTRACTORS EXAMINERS

consent

II

R. O. No. _____ - 18 - 19. By CITY CLERK. March 18, 2019.

Submitting various license applications.

City Clerk

TEMPORARY CLASS "B" LICENSE (AMENDED)

<u>No.</u>	<u>Name</u>	<u>Address</u>
3236	Sheboygan County Home Builders	637 Walton Drive, Plymouth - Three day event to be held 03/22/19-03/24/19 at Lakers Ice Center - 1202 S. Wildwood Ave. to include beer and wine.

TEMPORARY CLASS "B" LICENSE

<u>No.</u>	<u>Name</u>	<u>Address</u>
2184	Lutheran High Crusader Club	3323 University Drive - One day event to be held 04/13/2019 in the gymnasium to include beer and wine.

TEMPORARY BEVERAGE OPERATOR'S LICENSE

<u>No.</u>	<u>Name</u>	<u>Address</u>
4984	Jentsch, Allan A.	3635 N. 17 th Street

consent

VI

R. C. No. _____ - 18 - 19. By LICENSING, HEARINGS, AND PUBLIC SAFETY
COMMITTEE. March 18, 2019.

Your Committee to whom was referred R. O. No. 210-18-19 by City Clerk
submitting various license applications; recommends granting the following
license:

BEVERAGE OPERATOR'S LICENSE (NEW) (June 30, 2020)

<u>No.</u>	<u>Name</u>	<u>Address</u>
2577	Heard, Cecilia K.	220 Western Avenue, Plymouth

Consent

_____	_____
_____	_____
_____	_____

Committee

I HEREBY CERTIFY that the foregoing Committee Report was duly accepted
and adopted by the Common Council of the City of Sheboygan, Wisconsin, on the
_____ day of _____, 20____.

Dated _____ 20____. _____, City Clerk
Approved _____ 20____. _____, Mayor

II

Other Matters

R. O. No. 210 - 18 - 19. By CITY CLERK. January 21, 2019.

Submitting various license applications for the period ending December 31, 2019 and June 30, 2020.

City Clerk

BEVERAGE OPERATOR'S LICENSE (NEW) (June 30, 2020)

<u>No.</u>	<u>Name</u>	<u>Address</u>
2573	Alexander, Correy J.	2419 N. 9 th Street
0664	Gottsacker, Nathaniel D.	2518 S. 36 th Street
2577	Heard, Cecilia K.	220 Western Avenue, Plymouth
2570	Hendricks, Emily R.	1522 N. 10 th Street
2571	Kleefisch, Kayla M.	533 S. 26 th Street
2567	Kummer, Richard W.	3736 S. Taylor Drive
2579	Leavitt, Kaley F.	1245 Trimmerger Court
7725	Nelson, Amy A.	1016 North Avenue
6752	Ornelas, Noemi K.	914 Division Street, Manitowoc
2576	Randhawa, Prince K.	N 6233 Woodland Road
3735	Sackett, Tina M.	939 N. 25 th Street
2572	Salata-Labudde, Monica K.	414 Michigan Avenue Unit A

TAXICAB DRIVERS LICENSE (NEW) (December 31, 2019)

<u>No.</u>	<u>Name</u>	<u>Address</u>
2558	Bogart, Thomas Jr.	1616 N. 12 th Street
1300	Evraets, Ernest R.	528 S. 14 th Street

Handwritten notes:
AAPS
1-30 Hold #2577 (Heard)
3-13-19 Grant #2577 (Heard)

VII

R. C. No. _____ - 18 - 19. By LICENSING, HEARINGS, AND PUBLIC SAFETY COMMITTEE. March 18, 2019.

Your Committee to whom was referred, pursuant to R. O. No. 226-18-19 by City Clerk submitting various license applications; recommends granting the following licenses:

CHANGE OF PREMISE (PERMANENT)

<u>No.</u>	<u>Name</u>	<u>Address</u>
2949	Harrys Prohibition Bistro	668 South Pier Drive - Alcohol will be served within the new constructed walls/barriers patio on the west side of Prohibition Bistro along the boardwalk. All alcohol will be stored inside the building and no alcohol will be left outside after business hours.

BEVERAGE OPERATOR'S LICENSE (NEW) (June 30, 2020)

<u>No.</u>	<u>Name</u>	<u>Address</u>
2616	Birenbaum, Jenipher A.	1930 N. 7 th Street
2619	Campbell, Rebecca	1504 Illinois Avenue
0727	Fetterer, Aina L.	4407 Primrose Court #P208
2622	Guy, Le'Shay L.	4918 Windward Court Apt. 16
2613	Lietzau, Julie M.	8512 Pigeon Lake Road, Valders
2617	Olvera, Juan F.	718 Superior Avenue
2614	Raml, Jennifer L.	2605 N. 9 th Street
2615	Rutherford, Amy L.	2220 S. 42 nd Street, Manitowoc
2112	Schreiner, Kurt	1231 N. 8 th Street
9913	Steinberg, Rebecca M.	1811 N. 3 rd Street

TAXICAB DRIVERS LICENSE (NEW) (December 31, 2019)

<u>No.</u>	<u>Name</u>	<u>Address</u>
2428	Flunker, Angela S.	3616 Larkspar Way
0677	Perez-Velo, Erik F.	1623 Saemann Avenue
7238	Schaal, Kelli J.	1505 St. Clair Avenue

Consent

Massage License (NEW) (December 31, 2019)

<u>No.</u>	<u>Name</u>	<u>Address</u>
2044	Groove Salon	1227 N. 8 th Street

Committee

I HEREBY CERTIFY that the foregoing Committee Report was duly accepted and adopted by the Common Council of the City of Sheboygan, Wisconsin, on the _____ day of _____, 20____.

Dated _____ 20____. _____, City Clerk
Approved _____ 20____. _____, Mayor

VIII

R. C. No. _____ - 18 - 19. By FINANCE AND PERSONNEL COMMITTEE.
March 18, 2019.

Your Committee to whom was referred Res. No. 180-18-19 by Alderpersons Rindfleisch and Bohren authorizing the Purchasing Agent to issue a purchase order for the purchase of the 20 BCycle Bike Share Program and related software for use in the downtown and the waterfront areas; recommends approving the Resolution.

Consent

_____ Committee

I HEREBY CERTIFY that the foregoing Committee Report was duly accepted and adopted by the Common Council of the City of Sheboygan, Wisconsin, on the _____ day of _____, 20____.

Dated _____ 20____, _____, City Clerk

Approved _____ 20____, _____, Mayor

III

Res. No. 180 18 - 19. By Alderpersons Rindfleisch and Bohren.
March 4, 2019.

A RESOLUTION authorizing the Purchasing Agent to issue a purchase order for the purchase of the 20 BCycle Bike Share Program and related software for use in the downtown and the waterfront areas.

WHEREAS, city staff have done extensive research of bike share options and have determined that the BCycle Bike Share Program would best meet the needs of the Sheboygan bike share program, since Milwaukee and Madison also use this system which would allow the user the option of also renting at those locations; and

WHEREAS, 20 bikes would be spread out between the lakefront, South Pier, and the downtown and would be available for public use; and

WHEREAS, the Parking Utility would operate and maintain the program for the city in partnership with the City Development Department; and

WHEREAS, the total cost of a 20 BCycle Bike Share Program is \$57,700 for bicycles and software, \$8,000 for an operation fee to be paid to BCycle for two years of operation, and \$2,500 in maintenance costs to be paid into a fund for the use of the Parking Utility.

Finance & Personnel
approve

NOW, THEREFORE, BE IT RESOLVED: That the Purchasing Agent is authorized to issue a Purchase Order to BCYCLE, Waterloo, WI for \$65,700 and to the Parking Utility for \$2,500 and draw orders upon the following account numbers in payment of same:

Tourism-Advertising & Marketing	26054100-521400	\$30,200
TID16-Capital Project Fund- Improvements Other Than Buildings	42661100-631100	\$38,000

Ronald R. Flynn

James A. Bohre

I HEREBY CERTIFY that the foregoing Resolution was duly passed by the Common Council of the City of Sheboygan, Wisconsin, on the _____ day of _____, 20____.

Dated _____ 20____. _____, City Clerk

Approved _____ 20____. _____, Mayor



R. C. No. _____ - 18 - 19. By FINANCE AND PERSONNEL COMMITTEE.
March 18, 2019.

Your Committee to whom was referred Res. No. 181-18-19 by Alderpersons Rindfleisch and Bohren authorizing the Senior Activity Center of Sheboygan to accept a donation of an automated external defibrillator (AED) to be placed at the Senior Activity Center; recommends approving the Resolution.

Consent

_____ Committee

I HEREBY CERTIFY that the foregoing Committee Report was duly accepted and adopted by the Common Council of the City of Sheboygan, Wisconsin, on the _____ day of _____, 20____.

Dated _____ 20____. _____, City Clerk

Approved _____ 20____. _____, Mayor

1111

III

Res. No. 181 - 18 - 19. By Alderpersons Rindfleisch and Bohren.
March 4, 2019.

A RESOLUTION authorizing the Senior Activity Center of Sheboygan to accept a donation of an automated external defibrillator (AED) to be placed at the Senior Activity Center.

WHEREAS, the Senior Activity Center of Sheboygan has received an offer for a donation of an AED from Aurora Health Care; and

WHEREAS, the Senior Activity of Sheboygan wishes to accept the donation.

NOW, THEREFORE, BE IT RESOLVED: That the Supervisor of the Senior Activity Center of Sheboygan is hereby authorized to accept the donation of the AED from Aurora Health Care and execute the letter agreement with Aurora Health Care, a copy of which is attached hereto and incorporated herein.

Paul Rindfleisch
Janeva Bohren

*Finance & Personnel
approve*

I HEREBY CERTIFY that the foregoing Resolution was duly passed by the Common Council of the City of Sheboygan, Wisconsin, on the _____ day of _____, 20____.

Dated _____ 20____. _____, City Clerk

Approved _____ 20____. _____, Mayor



February 15, 2019

Wendy Schmitz, Supervisor
Senior Activity Center of Sheboygan
428 Wisconsin Ave, Sheboygan, WI 53081

Dear Wendy:

In 2015, Aurora Health Care launched the *When Minutes Matter* campaign, to not only improve cardiac arrest survival rates, but also to improve pre-hospital medicine in Ozaukee and Sheboygan Counties.

One initiative of the campaign was to remedy the lack of automated external defibrillators (AED) for public access and use in the communities we serve. In order to address this need, Aurora undertook an AED assessment in Ozaukee and Sheboygan Counties to determine where AED gaps exist within the community. Upon completion of the assessment, Aurora would distribute, through Aurora Health Care Foundation, AEDs to community partners for public access, allowing us to better the health in our communities and to meet community needs.

We are excited to share that your non-profit organization, Senior Activity Center of Sheboygan, has been identified to receive an AED from the Aurora Health Care Foundation.

With your acceptance of this gift, you agree to the following:

- You will place the device in a publicly accessible area within 4 weeks of receipt and will put up signs to appropriately direct the public to the device.
- An initial, one session, training opportunity will be provided by Aurora Health Care to the organization at a mutually agreeable date/time. Ongoing training will be your sole responsibility; Aurora will not provide any ongoing training.
- All maintenance and further costs (i.e. replacement batteries, replacement pads, etc) associated with the placement or use of the AED will be your sole responsibility.
- Maintenance or replacement parts can be obtained, at your cost, by contacting Scott Mullenberg, Account Executive at Allied 100, LLC at 715-356-0249 or scott@aed.com.
- You will provide complete contact information to device manufacturer, Allied 100, LLC, so it may be registered to your organization, activate the warranty and receive the indemnification coverage from Allied 100, LLC as the owner/end user of the device.
- Should you ever close your doors or be unable to maintain the device properly, you will promptly, and at your cost, return the AED to Aurora Medical Center in Grafton's EMS team so it may be donated to another organization in need.



- You acknowledge and agree that no Aurora entity (including without limitation, Aurora Health Care Foundation) shall have any ongoing liability for this AED or for any use thereof by the community.

If you are able and willing to accept the AED and these terms, please return an executed copy of this agreement in the enclosed self-addressed, stamped envelope. In addition, if you have any questions, please contact us at 262-329-1910. We look forward to working with you.

Sincerely,

A handwritten signature in black ink, appearing to read "Steven Zils MD".

Steven Zils, MD
Out-of-hospital Medical Director
Aurora Health Care

A handwritten signature in black ink, appearing to read "Randy Varju".

Randy Varju
President
Aurora Health Care Foundation

Acknowledged and Agreed to

Senior Activity Center of Sheboygan

Wendy Schmitz
Supervisor

VIII

R. C. No. _____ - 18 - 19. By PUBLIC WORKS COMMITTEE. March 18, 2019.

Your Committee to whom was referred Res. No. 185-18-19 by Alderpersons Wolf and Sorenson authorizing the appropriate City officials to enter into a contract for the 2019 Sidewalk Program project; recommends approving the Resolution.

Consent

Committee

I HEREBY CERTIFY that the foregoing Committee Report was duly accepted and adopted by the Common Council of the City of Sheboygan, Wisconsin, on the _____ day of _____, 20____.

Dated _____ 20____. _____, City Clerk

Approved _____ 20____. _____, Mayor

III

5.7

Res. No. 185- 18 - 19. By Alderpersons Wolf and Sorenson.
March 4, 2019.

A RESOLUTION authorizing the appropriate City officials to enter into a contract for the 2019 Sidewalk Program project.

WHEREAS, pursuant to Resolution No. 165-18-19, the Engineering Division of the Department of Public Works has advertised for bids for the 2019 Sidewalk Program project; and

WHEREAS, one bid was received in response to that advertisement; and

WHEREAS, the bid was from:

Klunck Masonry, LLC \$82,050.00; and

WHEREAS, the City Engineer has reviewed the bids and determined that the low bid, from Klunck Masonry, LLC, met all of the specifications.

NOW, THEREFORE, BE IT RESOLVED: That the appropriate City officials are hereby authorized to enter into the attached contract with Klunck Masonry, LLC for the 2019 Sidewalk Program Project in the amount of \$82,050.00 and are authorized to draw funds from the following account:

Sidewalk/Trail Improvements 40033140-631300 \$82,050.00

Public works approve





I HEREBY CERTIFY that the foregoing Resolution was duly passed by the Common Council of the City of Sheboygan, Wisconsin, on the _____ day of _____, 20____.

Dated _____ 20 . _____, City Clerk

Approved _____ 20 . _____, Mayor

4.02 Contract Times: Dates

- A. The Work will be substantially completed on or before August 16, 2019 and completed and ready for final payment in accordance with Paragraph 15.06 of the General Conditions on or before the 14th day following substantial completion.

4.03 Liquidated Damages

- A. Contractor and Owner recognize that time is of the essence as stated in Paragraph 4.01 above and that Owner will suffer financial and other losses if the Work is not completed and Milestones not achieved within the times specified in Paragraph 4.02 above, plus any extensions thereof allowed in accordance with the Contract. The parties also recognize the delays, expense, and difficulties involved in proving in a legal or arbitration proceeding the actual loss suffered by Owner if the Work is not completed on time. Accordingly, instead of requiring any such proof, Owner and Contractor agree that as liquidated damages for delay (but not as a penalty):

1. **Substantial Completion:** Contractor shall pay Owner the amount identified in paragraph 19.01 of the Supplementary Conditions for each day that expires after the time (as duly adjusted pursuant to the Contract) specified in Paragraph 4.02.A above for Substantial Completion until the Work is substantially complete.
2. **Completion of Remaining Work:** After Substantial Completion, if Contractor shall neglect, refuse, or fail to complete the remaining Work within the Contract Times (as duly adjusted pursuant to the Contract) for completion and readiness for final payment, Contractor shall pay Owner the amount identified in paragraph 19.01 of the Supplementary Conditions for each day that expires after such time until the Work is completed and ready for final payment.
3. Liquidated damages for failing to timely attain Substantial Completion and final completion are not additive and will not be imposed concurrently.
4. **Milestones:** Contractor shall pay Owner the amount identified in paragraph 19.01 of the Supplementary Conditions for each day that expires after the time (as duly adjusted pursuant to the Contract) specified above for achievement of Milestone 1, until Milestone 1 is achieved.

4.04 Special Damages

- A. In addition to the amount provided for liquidated damages, Contractor shall reimburse Owner (1) for any fines or penalties imposed on Owner as a direct result of the Contractor's failure to attain Substantial Completion according to the Contract Times, and (2) for the actual costs reasonably incurred by Owner for engineering, construction observation, inspection, and administrative services needed after the time specified in Paragraph 4.02 for Substantial Completion (as duly adjusted pursuant to the Contract), until the Work is substantially complete.
- B. After Contractor achieves Substantial Completion, if Contractor shall neglect, refuse, or fail to complete the remaining Work within the Contract Times, Contractor shall reimburse Owner for the actual costs reasonably incurred by Owner for engineering, construction observation, inspection, and administrative services needed after the time specified in Paragraph 4.02 for Work to be completed and ready for final payment (as duly adjusted pursuant to the Contract), until the Work is completed and ready for final payment.

ARTICLE 5 – CONTRACT PRICE

5.01 Owner shall pay Contractor for completion of the Work in accordance with the Contract Documents the amounts that follow, subject to adjustment under the Contract:

- A. For all Work, at the prices stated in Contractor's Bid, attached hereto as an exhibit.

ARTICLE 6 – PAYMENT PROCEDURES

6.01 *Submittal and Processing of Payments*

- A. Contractor shall submit Applications for Payment in accordance with Article 15 of the General Conditions. Applications for Payment will be processed by Engineer as provided in the General Conditions.

6.02 *Progress Payments; Retainage*

- A. Owner shall make progress payments on account of the Contract Price on the basis of Contractor's Applications for Payment on or about the 1st day of each month during performance of the Work as provided in Paragraph 6.02.A.1 below, provided that such Applications for Payment have been submitted in a timely manner and otherwise meet the requirements of the Contract. All such payments will be measured by the Schedule of Values established as provided in the General Conditions (and in the case of Unit Price Work based on the number of units completed) or, in the event there is no Schedule of Values, as provided elsewhere in the Contract.

- 1. Prior to Substantial Completion, progress payments will be made in an amount equal to the percentage indicated below but, in each case, less the aggregate of payments previously made and less such amounts as Owner may withhold, including but not limited to liquidated damages, in accordance with the Contract

- a. 95 percent of Work completed (with the balance being retainage). If the Work has been 50 percent completed as determined by Engineer, and if the character and progress of the Work have been satisfactory to Owner and Engineer, then as long as the character and progress of the Work remain satisfactory to Owner and Engineer, there will be no additional retainage; and

- b. 0 percent of cost of materials and equipment not incorporated in the Work (with the balance being retainage).

- B. Upon Substantial Completion, Owner shall pay an amount sufficient to increase total payments to Contractor to 100 percent of the Work completed, less such amounts set off by Owner pursuant to Paragraph 15.01.E of the General Conditions, and less 200 percent of Engineer's estimate of the value of Work to be completed or corrected as shown on the punch list of items to be completed or corrected prior to final payment.

6.03 *Final Payment*

- A. Upon final completion and acceptance of the Work in accordance with Paragraph 15.06 of the General Conditions, Owner shall pay the remainder of the Contract Price as recommended by Engineer as provided in said Paragraph 15.06.

ARTICLE 7 – INTEREST

7.01 All amounts not paid when due shall bear interest at the rate of 0 percent per annum.

ARTICLE 8 – CONTRACTOR’S REPRESENTATIONS

8.01 In order to induce Owner to enter into this Contract, Contractor makes the following representations:

- A. Contractor has examined and carefully studied the Contract Documents, and any data and reference items identified in the Contract Documents.
- B. Contractor has visited the Site, conducted a thorough, alert visual examination of the Site and adjacent areas, and become familiar with and is satisfied as to the general, local, and Site conditions that may affect cost, progress, and performance of the Work.
- C. Contractor is familiar with and is satisfied as to all Laws and Regulations that may affect cost, progress, and performance of the Work.
- D. Contractor has carefully studied all: (1) reports of explorations and tests of subsurface conditions at or adjacent to the Site and all drawings of physical conditions relating to existing surface or subsurface structures at the Site that have been identified in the Supplementary Conditions, especially with respect to Technical Data in such reports and drawings, and (2) reports and drawings relating to Hazardous Environmental Conditions, if any, at or adjacent to the Site that have been identified in the Supplementary Conditions, especially with respect to Technical Data in such reports and drawings.
- E. Contractor has considered the information known to Contractor itself; information commonly known to contractors doing business in the locality of the Site; information and observations obtained from visits to the Site; the Contract Documents; and the Site-related reports and drawings identified in the Contract Documents, with respect to the effect of such information, observations, and documents on (1) the cost, progress, and performance of the Work; (2) the means, methods, techniques, sequences, and procedures of construction to be employed by Contractor; and (3) Contractor’s safety precautions and programs.
- F. Based on the information and observations referred to in the preceding paragraph, Contractor agrees that no further examinations, investigations, explorations, tests, studies, or data are necessary for the performance of the Work at the Contract Price, within the Contract Times, and in accordance with the other terms and conditions of the Contract.
- G. Contractor is aware of the general nature of work to be performed by Owner and others at the Site that relates to the Work as indicated in the Contract Documents.
- H. Contractor has given Engineer written notice of all conflicts, errors, ambiguities, or discrepancies that Contractor has discovered in the Contract Documents, and the written resolution thereof by Engineer is acceptable to Contractor.
- I. The Contract Documents are generally sufficient to indicate and convey understanding of all terms and conditions for performance and furnishing of the Work.
- J. Contractor’s entry into this Contract constitutes an incontrovertible representation by Contractor that without exception all prices in the Agreement are premised upon performing and furnishing the Work required by the Contract Documents.

ARTICLE 9 – CONTRACT DOCUMENTS

9.01 Contents

- A. The Contract Documents consist of the following:
1. This Agreement (pages 00 52 00-1 to -[], inclusive).
 2. Performance bond (pages 00 61 13-1 to 00 61 13 - ____, inclusive).
 3. Payment bond (pages 00 61 14-1 to 00 61 14- ____, inclusive).
 4. General Conditions (EJCDC C-700, 2013 Edition) Supplementary Conditions, Specifications, and Drawings, not attached but incorporated by reference, as listed in the attached table of contents of the Project Manual.
 5. Addenda (not attached but incorporated by reference) (numbers 1 to -[], inclusive).
 6. Exhibits to this Agreement (enumerated as follows):
 - a. Contractor’s Bid (pages 1 to -[], inclusive).
 7. The following which may be delivered or issued on or after the Effective Date of the Contract and are not attached hereto:
 - a. Notice to Proceed,
 - b. Work Change Directives,
 - c. Change Orders,
 - d. Field Order,
 - e. Task Orders.
- B. The documents listed in Paragraph 9.01.A are attached to this Agreement (except as expressly noted otherwise above).
- C. There are no Contract Documents other than those listed above in this Article 9.
- D. The Contract Documents may only be amended, modified, or supplemented as provided in the General Conditions.

ARTICLE 10 – MISCELLANEOUS

10.01 Terms

- A. Terms used in this Agreement will have the meanings stated in the General Conditions and the Supplementary Conditions.

10.02 Assignment of Contract

- A. Unless expressly agreed to elsewhere in the Contract, no assignment by a party hereto of any rights under or interests in the Contract will be binding on another party hereto without the written consent of the party sought to be bound; and, specifically but without limitation, money that may become due and money that is due may not be assigned without such consent (except to the extent that the effect of this restriction may be limited by law), and unless specifically stated to the contrary in any written consent to an assignment, no assignment will release or discharge the assignor from any duty or responsibility under the Contract Documents.

10.03 Successors and Assigns

- A. Owner and Contractor each binds itself, its successors, assigns, and legal representatives to the other party hereto, its successors, assigns, and legal representatives in respect to all covenants, agreements, and obligations contained in the Contract Documents.

10.04 Severability

- A. Any provision or part of the Contract Documents held to be void or unenforceable under any Law or Regulation shall be deemed stricken, and all remaining provisions shall continue to be valid and binding upon Owner and Contractor, who agree that the Contract Documents shall be reformed to replace such stricken provision or part thereof with a valid and enforceable provision that comes as close as possible to expressing the intention of the stricken provision.

10.05 Contractor's Certifications

- A. Contractor certifies that it has not engaged in corrupt, fraudulent, collusive, or coercive practices in competing for or in executing the Contract. For the purposes of this Paragraph 10.05:
1. "corrupt practice" means the offering, giving, receiving, or soliciting of any thing of value likely to influence the action of a public official in the bidding process or in the Contract execution;
 2. "fraudulent practice" means an intentional misrepresentation of facts made (a) to influence the bidding process or the execution of the Contract to the detriment of Owner, (b) to establish Bid or Contract prices at artificial non-competitive levels, or (c) to deprive Owner of the benefits of free and open competition;
 3. "collusive practice" means a scheme or arrangement between two or more Bidders, with or without the knowledge of Owner, a purpose of which is to establish Bid prices at artificial, non-competitive levels; and
 4. "coercive practice" means harming or threatening to harm, directly or indirectly, persons or their property to influence their participation in the bidding process or affect the execution of the Contract.

10.06 Other Provisions

- A. Owner stipulates that if the General Conditions that are made a part of this Contract are based on EJCDC® C-700, Standard General Conditions for the Construction Contract, published by the Engineers Joint Contract Documents Committee®, and if Owner is the party that has furnished said General Conditions, then Owner has plainly shown all modifications to the standard wording of such published document to the Contractor, through a process such as highlighting or "track changes" (redline/strikeout), or in the Supplementary Conditions.

(Continued on next page)

IN WITNESS WHEREOF, Owner and Contractor have signed this Agreement.

This Agreement will be effective on _____ (which is the Effective Date of the Contract).

OWNER:

CONTRACTOR:

City of Sheboygan

By: _____
(signature)

Name,
Title: Darrell Hofland , City Administrator

Date: _____

By: _____
(signature)

Name,
Title: _____
(printed)

Date: _____

(If Contractor is a corporation, a partnership, or a joint venture, attach evidence of authority to sign.)

Address for giving notices:

City of Sheboygan - Engineering
2026 New Jersey Avenue
Sheboygan, WI 53081

Address for giving notices:

License No.: _____
(where applicable)

Signed by:

Approved as to form and Execution:

By: _____
(signature)

Name,
Title: Michael Vandersteen, Mayor

Date: _____

By: _____
(signature)

Name,
Title: Charles C. Adams, City Attorney

Date: _____

Countersigned by:

By: _____
(signature)

Name,
Title: Meredith DeBruin, City Clerk

Date: _____

2019 Sidewalk Program

SECTION	TITLE	PAGES
00 00 00	PROCUREMENT AND CONTRACTING REQUIREMENTS	
00 01 01	Cover	00 01 01-1
00 01 10	Table of Contents	00 01 10-1 to 00 01 10-1
00 11 13	Advertisements for Bids	00 11 13-1
00 21 13	Instructions for Bidders	00 21 13-1 to 00 21 13-10
00 41 43	Bid Form	00 41 43-1 to 00 41 43-5
00 41 44	Unit Price Worksheet	00 41 44-1
00 41 44.1	Quest Unit Price Worksheet	1 Pages
00 42 13	Bid Bond	00 42 13-1 to 00 42 13-2
00 45 13	Bidder's Proof of Responsibility	00 45 13-1 to 00 45-13-5
00 45 19	Non-Collusion Affidavit of Bidder	00 45 19-1
00 45 20	Non-Collusion Affidavit of Subcontractor	00 45 20-1
00 45 50	List of Subcontractors	00 45 50-1
00 52 00	Agreement	00 52 00-1 to 00 52 00-8
00 55 00	Notice to Proceed	00 55 00-1
00 61 13	Performance Bond	00 61 13-1 to 00 61 13-3
00 61 14	Payment Bond	00 61 14-1 to 00 61 14-3
00 62 11	Submittal Cover	00 62 11-1
00 62 76	Application for Payment	00 62 76-1 to 00 62 76-2
00 63 13	Request for Information	00 63 13-1
00 63 49	Work Change Directive	00 63 49-1
00 63 63	Change Order Form	00 63 63-1
00 65 16	Certificate of Substantial Completion	00 65 16-1
00 65 18	Certificate of Compliance	00 65 13-1
00 65 19	Consent of Surety to Final Payment	00 65 19-1
00 72 00	General Conditions	00 72 00 -1 to 00 72 00-72
00 73 00	Supplementary Conditions	00 73 00-1 to 00 73 00-13
01 00 00	GENERAL REQUIREMENTS	
01 11 00	Summary of Work	01 11 00-1 to 01 11 00-2
01 14 00	Work Restrictions	01 14 00-1 to 01 14 00-6
01 57 19	Temporary Environmental Controls	01 57 19-1 to 01 57 19-2
32 00 00	EXTERIOR IMPROVEMENT	
32 10 50	Concrete Sidewalk Program	32 10 50-1 to 32 10 50-9

2432-19 2019 Sidewalk Program (#6111160)

Owner: Sheboygan WI, City of

Solicitor: Sheboygan WI, City of

02/19/2019 10:00 AM CST

						Klunck Masonry LLC	
Line Item	Item Code	Item Description	UofM	Quantity	Unit Price	Extension	
	1 2019-1	Remove Concrete Sidewalk and Approaches	SF	9000	\$1.00	\$9,000.00	
	2 2019-2	Remove Concrete Aprons	SF	100	\$2.00	\$200.00	
	3 2019-3	Remove Curb & Gutter	LF	150	\$7.50	\$1,125.00	
	4 2019-4	Remove Integral Sidewalk/Curb	SF	200	\$6.00	\$1,200.00	
	5 2019-5	Excessive Cut	CY	50	\$25.00	\$1,250.00	
	6 2019-6	Excessive Fill/Gravel	Cy	50	\$18.00	\$900.00	
	7 2019-7	Concrete Sidewalk 4-inch	SF	9000	\$6.00	\$54,000.00	
	8 2019-8	Concrete Sidewalk 6-inch	SF	500	\$6.25	\$3,125.00	
	9 2019-9	Concrete Apron 7-inch	SF	100	\$6.00	\$600.00	
	10 2019-10	Concrete Curb and Gutter 30-inch	LF	150	\$24.00	\$3,600.00	
	11 2019-11	Concrete Curb 6-inch	LF	50	\$7.00	\$350.00	
	12 2019-12	Integral Sidewalk & Curb	SY	200	\$5.50	\$1,100.00	
	13 2019-13	Concrete Sawing	LF	250	\$6.00	\$1,500.00	
	14 2019-14	Grading For New Sidewalk	SF	500	\$2.00	\$1,000.00	
	15 2019-15	4-inch Topsoil, Seed & Fertilizer	SY	60	\$15.00	\$900.00	
	16 2019-16	Concrete Sidewalk 6-inch with Panel Finish	SF	200	\$6.00	\$1,200.00	
	17 2019-17	Curb Ramp Detectabel Warning Field	EA	10	\$100.00	\$1,000.00	
Total							\$82,050.00

II

R. O. No. _____ - 18 - 19. By CITY PLAN COMMISSION. March 18, 2019.

Your Commission to whom was referred Gen. Ord. No. 47-18-19 by Alderperson Phillips and R. O. No. 224-18-19 by City Clerk who submitted a communication from Prohibition Bistro (Avni and Harry Latifi), requesting an encroachment into portions of Lot 1 Promenade, South Pier for the purpose of expanding the outdoor patio area; wishes to report this matter was discussed at the regular meeting of the City Plan Commission, March 12, 2019, and after due consideration, recommends approval of the General Ordinance and R. O.

CITY PLAN COMMISSION

Reg.

~~X~~

Gen. Ord. No. 47 - 18 - 19. By Alderperson Phillips. March 4, 2019.

AN ORDINANCE granting Prohibition Bistro, its successors and assigns, the privilege of encroaching upon described portions of Lot 1 Promenade, South Pier located at 668 South Pier Drive in the City of Sheboygan for the purpose of expanding the outdoor patio area.

THE COMMON COUNCIL OF THE CITY OF SHEBOYGAN DO ORDAIN AS FOLLOWS:

Section 1. Subject to the terms and conditions contained herein, Prohibition Bistro, its successors and assigns, is hereby granted the privilege of encroaching upon described portions of Lot 1 Promenade, South Pier, located at 668 South Pier Drive as follows:

Part of Lot 1 Promenade, South Pier, located in Government Lot 1 of Section 26, T15N-R23E, City of Sheboygan, Sheboygan County, Wisconsin lying west of and adjacent to that part of Lot 2, South Pier as described in "Correction Instrument Consolidated and Restated Prohibition Bistro Ground Lease" as Document Number 1971182 described as: Commencing at the Northwest corner of Lot 2, South Pier, said point being the point of beginning; thence along the west line of said Lot 2, S22°48'04"W 59.90 feet; thence N69°23'27"W 15.88 feet; thence N23°44'57"E 56.40 feet; thence S82°35'49"E 15.49 feet to the point of beginning. SAID AREA CONTAINS 894 SQ. FT. (0.021 ACRE)

for the purpose of expanding the outdoor patio area, in accordance with the sketch attached hereto and made a part hereof.

Section 2. The privilege as granted above is granted only on the condition that by the acceptance of the privilege, the said Prohibition Bistro, its successors and assigns:

a. Shall become primarily responsible and liable for all and any damage to persons or property caused by and arising from the grant and exercise of such privilege.

b. Shall remove the encroachment allowed herein within ten (10) days after notice so to remove given by the State of Wisconsin or the City of Sheboygan; in the event of the failure so to remove, the said Prohibition Bistro, its successors and assigns: shall pay the costs of removal by the State of Wisconsin or the City of Sheboygan, waiving all claim or claims for damages resulting from such removal, whether the removal is done by the said Prohibition Bistro, its successors and assigns, or by the State of Wisconsin or by the City of Sheboygan.

*City Plan
Approved*

c. Shall pay such compensation to the City of Sheboygan for the grant of this privilege as may be determined by a board consisting of the Mayor, the Director of Public Works and the City Attorney; the compensation shall be paid into the General Fund.

d. Shall make such construction and/or alterations and maintain the same subject to the approval of the City Building Inspector and Director of Public Works, and shall waive the right to contest in any manner the validity of this ordinance or the amount of compensation charged.

Section 3. The provisions of §66.0425(1) thru (5) of the Wisconsin Statutes are incorporated herein by reference to all intents and purposes as if set out fully.

Section 4. The City Clerk is authorized and directed to record a certified copy of this ordinance in the office of the Register of Deeds for Sheboygan County, Wisconsin, the costs thereof to be charged to the General Fund.

Section 5. This ordinance shall take effect and be in full force from and after its passage and publication and upon payment of the consideration to be determined hereunder, provided, however, that in the event of failure to exercise the privilege herein granted and the payment of such consideration within six (6) months from the effective date hereof, then and in that event such privilege shall be rendered null and void.

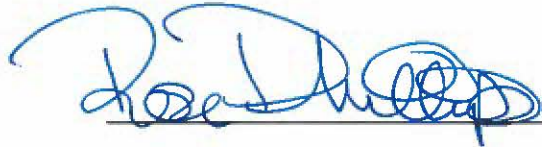

I HEREBY CERTIFY that the foregoing Ordinance was duly passed by the Common Council of the City of Sheboygan, Wisconsin, on the _____ day of _____, 20____.

Dated _____ 20____, _____, City Clerk

Approved _____ 20____, _____, Mayor

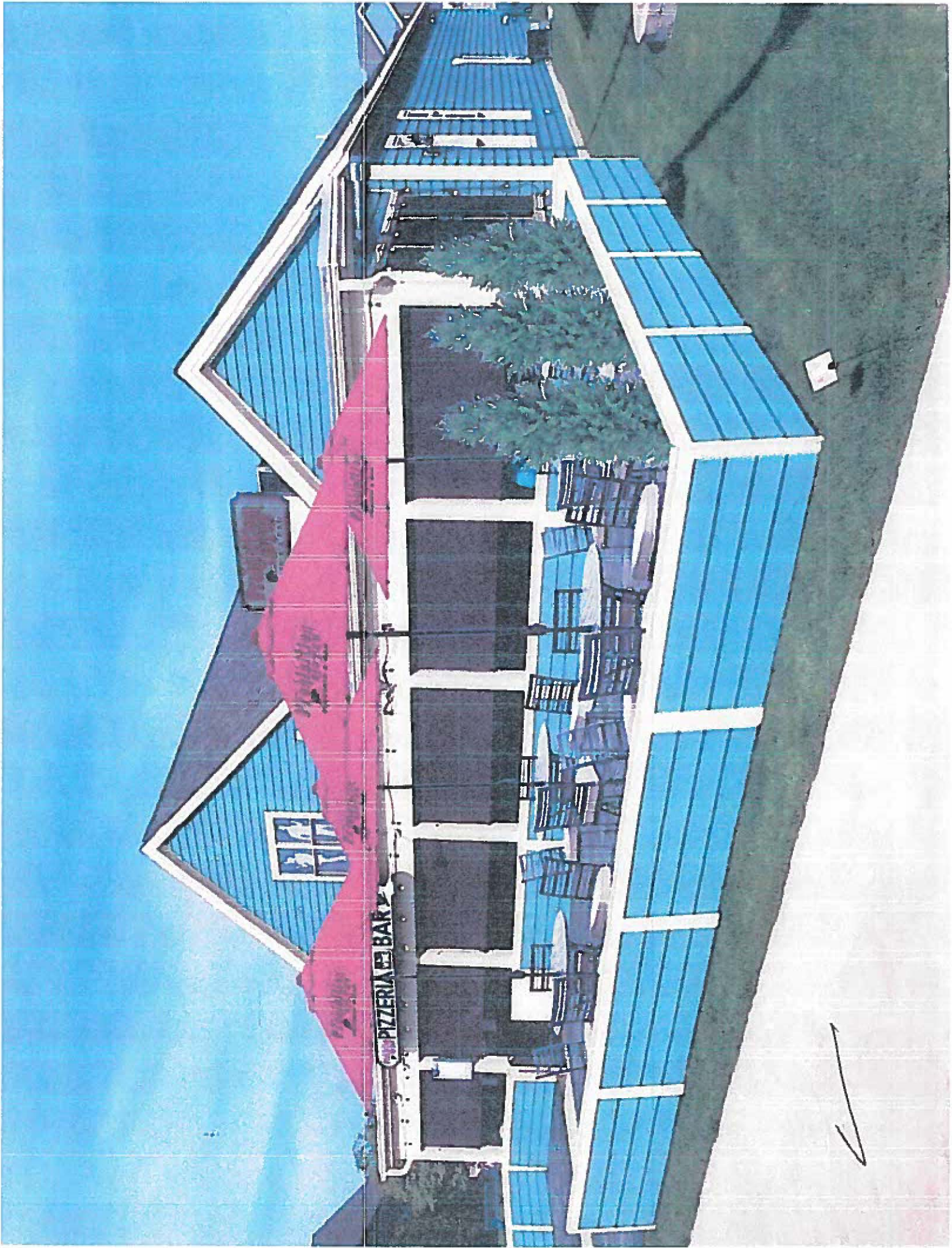

Encroachment Request
for
Prohibition Bistro 668 LLC

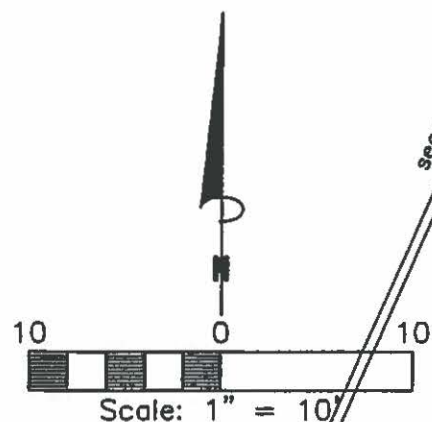

- = 1" iron pipe found
- ▲ = Large dia. nail found

Vertical Datum=City of Sheboygan
(Benchmark: Top of hydrant at
Pier Dr & Fisherman's Row, Elev 8.66)

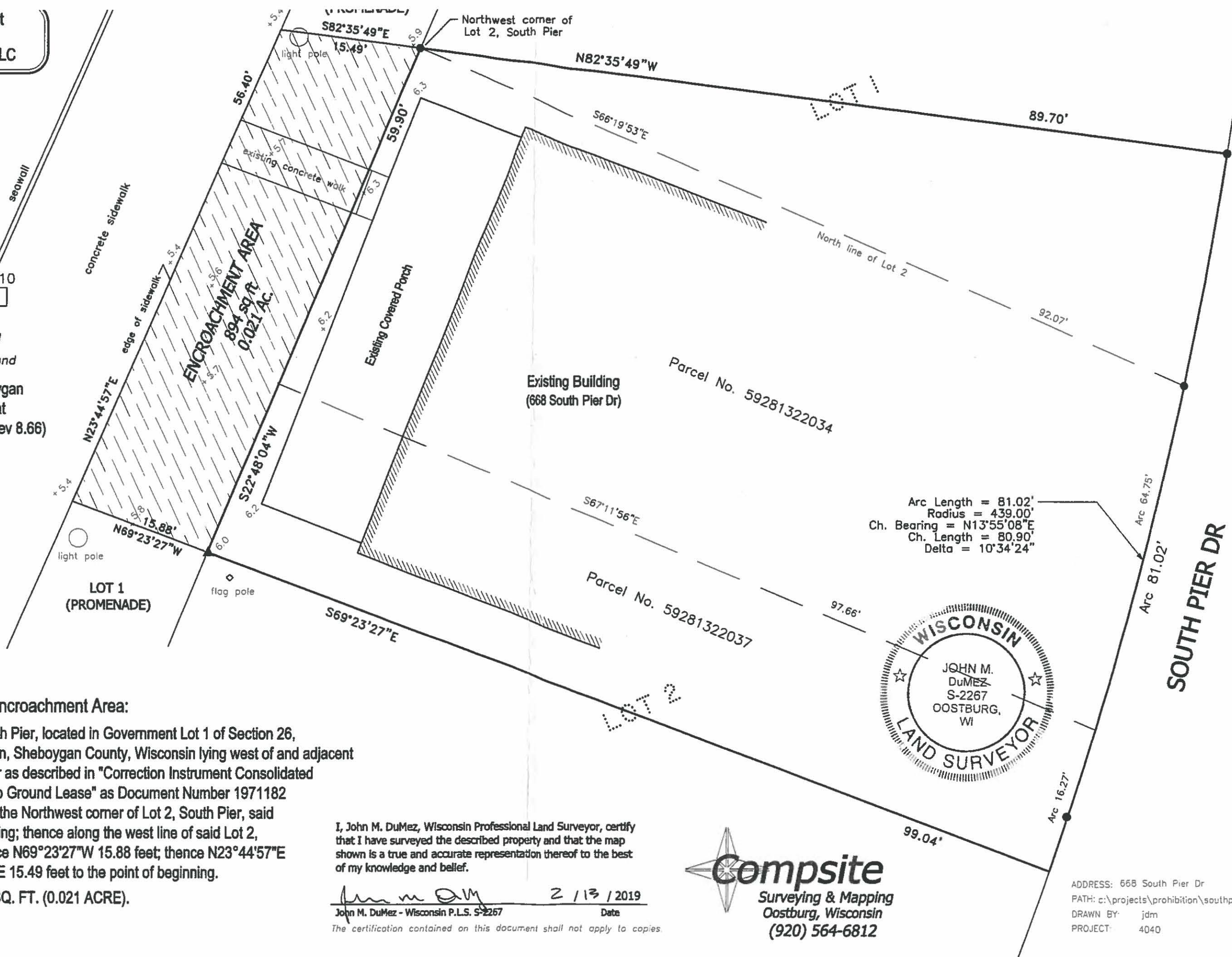

Description of Proposed Encroachment Area:

Part of Lot 1 Promenade, South Pier, located in Government Lot 1 of Section 26, T15N-R23E, City of Sheboygan, Sheboygan County, Wisconsin lying west of and adjacent to that part of Lot 2, South Pier as described in "Correction Instrument Consolidated and Restated Prohibition Bistro Ground Lease" as Document Number 1971182 described as: Commencing at the Northwest corner of Lot 2, South Pier, said point being the point of beginning; thence along the west line of said Lot 2, S22°48'04"W 59.90 feet; thence N69°23'27"W 15.88 feet; thence N23°44'57"E 56.40 feet; thence S82°35'49"E 15.49 feet to the point of beginning.

SAID AREA CONTAINS 894 SQ. FT. (0.021 ACRE).

I, John M. DuMez, Wisconsin Professional Land Surveyor, certify that I have surveyed the described property and that the map shown is a true and accurate representation thereof to the best of my knowledge and belief.

John M. DuMez 2/13/2019
John M. DuMez - Wisconsin P.L.S. S-2267 Date

The certification contained on this document shall not apply to copies.

Compsite
Surveying & Mapping
Oostburg, Wisconsin
(920) 564-6812

ADDRESS: 668 South Pier Dr
PATH: c:\projects\prohibition\southpier\dwg\
DRAWN BY: jdm
PROJECT: 4040

II

4.1

R. O. No. 224 - 18 - 19. By CITY CLERK. March 4, 2019.

Submitting a communication from Prohibition Bistro (Avni and Harry Latifi) requesting an encroachment into portions of Lot 1 Promenade, South Pier for the purpose of expanding the outdoor patio area.

CITY CLERK

*City Plan
approved*

FEB 20 '19 PM 1:17

02/20/19

Prohibition Bistro

668 South Pier Drive

Sheboygan, WI 53081

RE: Request for Encroachment at Prohibition Bistro- Addition of Patio on West Side of Building

Common Council of City of Sheboygan:

My brother, Harry and I are going into our 6th year of business at Prohibition Bistro and really enjoy the great location on beautiful South Pier.

Right now, we have a small patio area on the west side of the building overlooking the river. We have found this patio has become quite popular during our peak seasons. To meet the needs of increased business and make use of the grassy area existing, we are requesting an encroachment to extend our outdoor serving area. The new area would be enclosed by 3 foot walls and paved with bricks.

By expanding the outdoor patio area, we would be able to accommodate more locals and increase tourist interest on South Pier.

In working with Sasha Moco of Moco Construction, we have included photos of the proposed addition.

Regards,



Avni Latifi

owner



PIZZERIA BAR



**Encroachment Request
for
Prohibition Bistro 668 LLC**

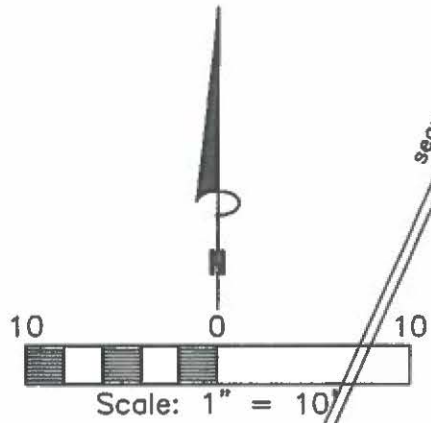

- = 1" iron pipe found
- ▲ = Large dia. nail found

Vertical Datum=City of Sheboygan
(Benchmark: Top of hydrant at
S. Pier Dr & Fisherman's Row, Elev 8.66)

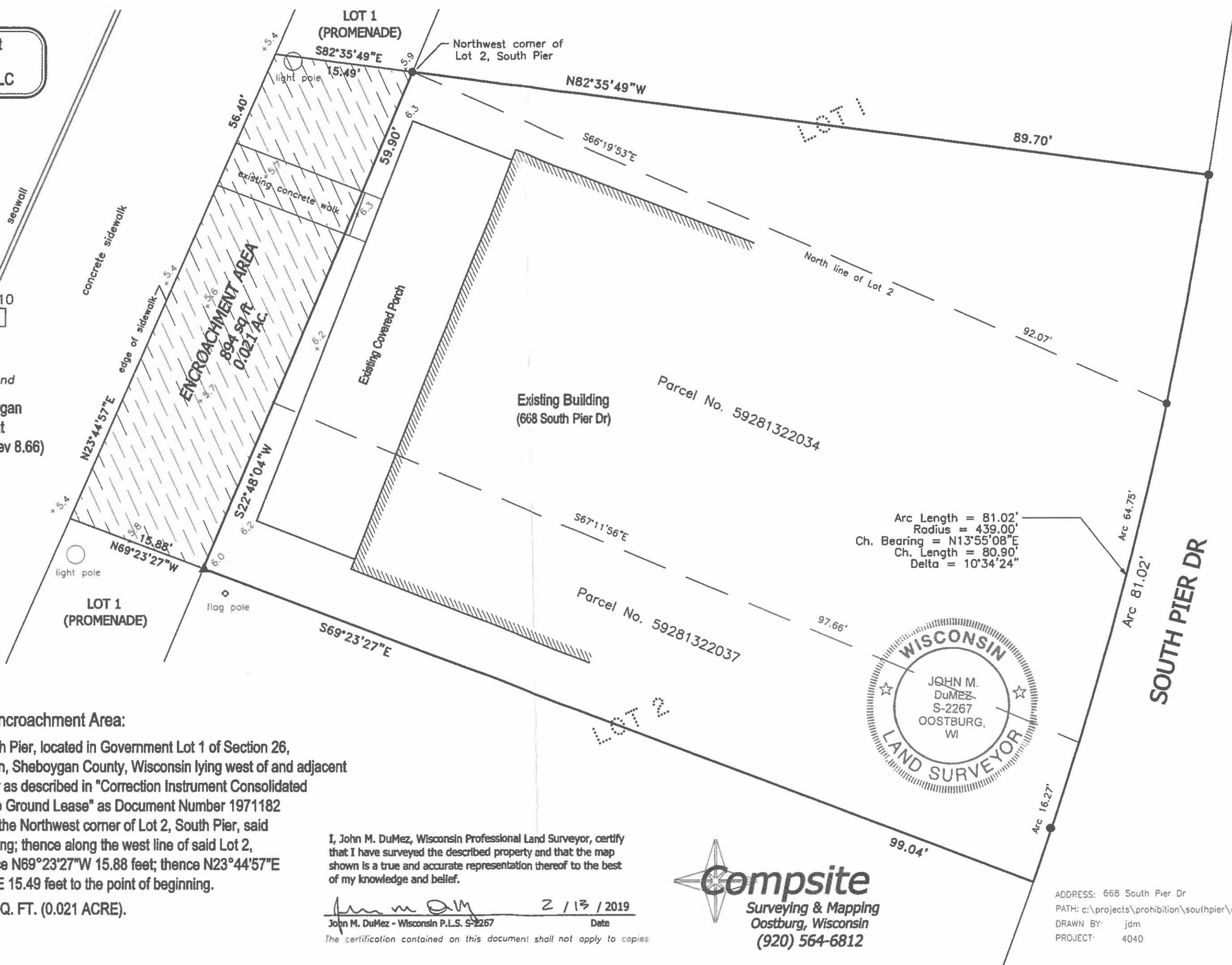

Description of Proposed Encroachment Area:

Part of Lot 1 Promenade, South Pier, located in Government Lot 1 of Section 26, T15N-R23E, City of Sheboygan, Sheboygan County, Wisconsin lying west of and adjacent to that part of Lot 2, South Pier as described in "Correction Instrument Consolidated and Restated Prohibition Bistro Ground Lease" as Document Number 1971182 described as: Commencing at the Northwest corner of Lot 2, South Pier, said point being the point of beginning; thence along the west line of said Lot 2, S22°48'04"W 59.90 feet; thence N69°23'27"W 15.88 feet; thence N23°44'57"E 56.40 feet; thence S82°35'49"E 15.49 feet to the point of beginning.

SAID AREA CONTAINS 894 SQ. FT. (0.021 ACRE).

I, John M. DuMez, Wisconsin Professional Land Surveyor, certify that I have surveyed the described property and that the map shown is a true and accurate representation thereof to the best of my knowledge and belief.

John M. DuMez 2 / 13 / 2019
John M. DuMez - Wisconsin P.L.S. S-2267 Date

The certification contained on this document shall not apply to copies

Compsite
Surveying & Mapping
Oostburg, Wisconsin
(920) 564-6812

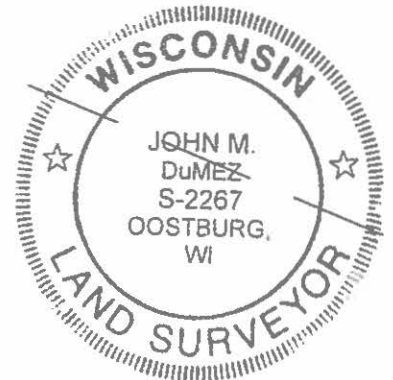

ADDRESS: 668 South Pier Dr
PATH: c:\projects\prohibition\southpier\dwg\
DRAWN BY: jdm
PROJECT: 4040

II

R. O. No. _____ - 18 - 19. By MAYOR. March 18, 2019.

Submitting a communication from Mayor Michael Vandersteen on behalf of the Great Lakes and St. Lawrence Cities Initiative requesting two of the City days for the 2019 Great Lakes and St. Lawrence Cities Initiative Annual Conference at Blue Harbor on June 6 and 7, 2019.

MAYOR MICHAEL VANDERSTEEN

Finance and Personnel

DATE RECEIVED 3-14-19

RECEIVED BY NKC

CLAIM NO. 3018 MAR 14 '19 AM 10:40

CITY OF SHEBOYGAN NOTICE OF DAMAGE OR INJURY

INSTRUCTIONS: TYPE OR PRINT IN BLACK INK

1. Notice of death, injury to persons or to property must be filed not later than 120 days after the occurrence.
2. Attach and sign additional supportive sheets, if necessary.
3. This notice form must be signed and filed with the Office of the City Clerk.

TWO ESTIMATES MUST BE ATTACHED IF YOU ARE CLAIMING DAMAGE TO A VEHICLE.

1. Name of Claimant: MARGARET A. BULKOW
2. Home address of Claimant: 125 S. 2ND ST. OOSTBURG, WI 53070
3. Home phone number: 920-564-5091
4. Business address and phone number of Claimant: _____

5. When did damage or injury occur? (date, time of day) 3-6-2019 @ 2:00 P.M.

6. Where did damage or injury occur? (give full description) MY CAR WAS PARKED FACING NORTHBOUND ON N 13th SOUTH OF NORTHAVE. A NORTH BOUND CITY BUS WENT PAST AND STRUCK MY DRIVERS SIDE MIRROR

7. How did damage or injury occur? (give full description) CITY BUS STRUCK THE DRIVERS SIDE MIRROR ON MY LEGALLY PARK VEHICLE

8. If the basis of liability is alleged to be an act or omission of a City officer or employee, complete the following:

(a) Name of such officer or employee, if known: _____

(b) Claimant's statement of the basis of such liability: CITY OF SHEBOYGAN BUS STRUCK MY DRIVERS SIDE MIRROR WHILE MY CAR WAS LEGALLY PARKED

9. If the basis of liability is alleged to be a dangerous condition of public property, complete the following:

(a) Public property alleged to be dangerous: _____

(b) Claimant's statement of basis for such liability: _____

UNITED STATES DEPARTMENT OF JUSTICE

FEDERAL BUREAU OF INVESTIGATION

MEMORANDUM FOR THE DIRECTOR, FBI

DATE: 10/10/50

RE: [Illegible]

[Illegible]

[Illegible]

[Illegible]

[Illegible]

[Illegible]

[Illegible]

[Illegible]

[Illegible]

[Illegible]

[Illegible]

[Illegible]

[Illegible]

[Illegible]

[Illegible]

[Illegible]

[Illegible]

[Illegible]

[Illegible]

[Illegible]

[Illegible]

[Illegible]

[Illegible]

[Illegible]

10. Give a description of the injury, property damage or loss, so far as is known at this time. (If there were no injuries, state "NO INJURIES").

NO INJURIES; CITY BUS STRUCK THE DRIVERS SIDE MIRROR ON MY PARKED VEHICLE

11. Name and address of any other person injured: NA

12. Damage estimate: (You are not bound by the amounts provided here.)

Auto: \$ 365.65
 Property: \$ —
 Personal injury: \$ —
 Other: (Specify below) \$ —
TOTAL \$ 365.65

Damaged vehicle (if applicable)

Make: CHEVROLET Model: EQUINOX Year: 2012 Mileage: 56,292

Names and addresses of witnesses, doctors and hospitals: NA

SHEBOYGAN POLICE DEPARTMENT INCIDENT NUMBER
CP-09464

FOR ALL ACCIDENT NOTICES, COMPLETE THE FOLLOWING DIAGRAM IN DETAIL. BE SURE TO INCLUDE NAMES OF ALL STREETS, HOUSE NUMBERS, LOCATION OF VEHICLES, INDICATING WHICH IS CITY VEHICLE (IF APPLICABLE), WHICH IS CLAIMANT VEHICLE, LOCATION OF INDIVIDUALS, ETC.

NOTE: If diagrams below do not fit the situation, attach proper diagram and sign.

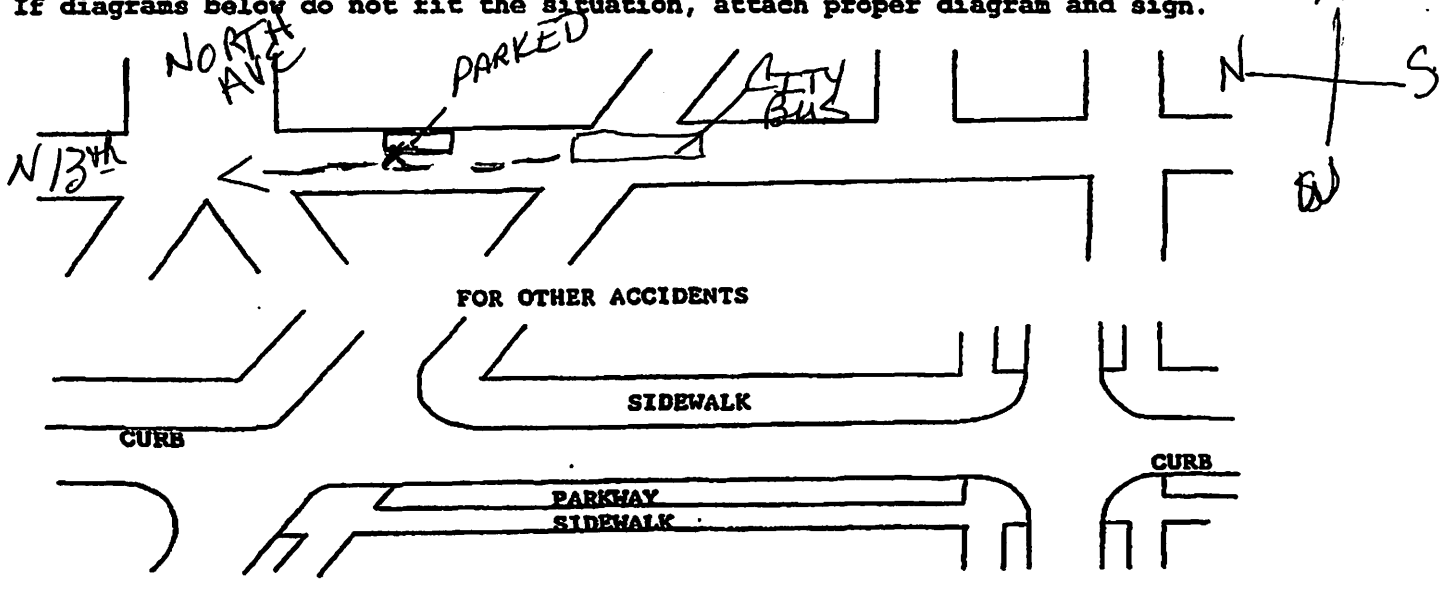

SIGNATURE OF CLAIMANT Margaret A. Bulbow

DATE 3-8-2019

DATE RECEIVED 3-14-19

RECEIVED BY MKC

CLAIM NO. 30-18

CLAIM

Claimant's Name: MARGARET A. BULKOW
Claimant's Address: 125 S. 2ND ST.
DOSTBURG, WI 53070
Claimant's Phone No. 920-564-5091

Auto \$ 365.65
Property \$ _____
Personal Injury \$ _____
Other (Specify below) \$ _____
TOTAL \$ 365.65

PLEASE INCLUDE COPIES OF ALL BILLS, INVOICES, ESTIMATES, ETC.

**WARNING: IT IS A CRIMINAL OFFENSE TO FILE A FALSE CLAIM.
(WISCONSIN STATUTES 943.395)**

The undersigned hereby makes a claim against the City of Sheboygan arising out of the circumstances described in the Notice of Damage or Injury. The claim is for relief in the form of money damages in the total amount of \$ 365.65.

SIGNED Margaret A. Bulkow

DATE: 3-8-2019

ADDRESS: 125 S 2ND ST. DOSTBURG, WI 53070

MAIL TO: CLERK'S OFFICE
828 CENTER AVE #100
SHEBOYGAN WI 53081

ROBERT RUSCH, INC.
1129 INDIANA AVENUE
SHEBOYGAN, WI. 53081
OFFICE:(920) 452-8681 FAX:(920) 452-8733

*** PRELIMINARY ESTIMATE ***

03/08/2019 11:33 AM

Owner

Owner: MARGRET BULKAOW
Address:

Work/Day: (920)564-5091

Inspection

Inspection Date: 03/08/2019 11:33 AM

Inspection Type:

Repairer

Repairer: Robert Rusch Inc.
Address: 1129 Indiana Ave.
City State Zip: Sheboygan, WI 53081
Email: doldenburg@robertruschinc.com

Contact: David Oldenburg
Work/Day: (920)452-8681
FAX: (920)452-8733

Target Complete Date/Time:

Days To Repair: 1

Vehicle

OEM Part Price Quote ID: ****

2012 Chevrolet Equinox 1LT 4 DR Wagon
6cyl Gasoline 3.0 Dohc
6-Speed Automatic

Lic Expire:
Veh Insp# :
Condition:
Ext. Refinish: Two-Stage

VIN: 2GNFLEE52C6296878
Mileage Type: Actual
Code: U7714B
Int. Refinish: Two-Stage

Options

1st Row LCD Monitor(s)
AM/FM CD Player
Aluminum/Alloy Wheels
Auxiliary Audio Input
Cruise Control
Electric Steering
Halogen Headlights
Heated Rear Wiper Park
Intermittent Wipers
Lighted Entry System
Power Door Locks
Pwr Driver Lumbar Supp
Rear View Camera
Reverse Sensing System
Skid Plates
Strg Wheel Radio Control
Tilt & Telescopic Steer
Traction Control System

2nd Row Head Airbags
Air Conditioning
Anti-Lock Brakes
Bucket Seats
Daytime Running Lights
Emergency S.O.S. System
Head Airbags
Heated W/S Wiper Washers
Keyless Entry System
MP3 Decoder
Power Windows
Rear Spoiler
Rear Window Defroster
Roof/Luggage Rack
Split Folding Rear Seat
Tachometer
Tire Pressure Monitor
Trip Computer

4-Wheel Drive
Alarm System
Auto Headlamp Control
Center Console
Dual Airbags
Floor Mats
Heated Power Mirrors
Illuminated Visor Mirror
Leather Steering Wheel
Power Brakes
Privacy Glass
Rear Step Bumper
Rear Window Wiper/Washer
Side Airbags
Stability Cntrl Suspensn
Theft Deterrent System
Touch Screen Display
Velour/Cloth Seats

Wireless Phone Connect XM Satellite Radio

Damages

Line	Op	Guide	MC	Description	MFR.Part No.	Price	ADJ%	B%	Hours	R
Front Doors										
1	E	266		Mirror,Outer R/C LT	22818288 GM Part	\$180.05			1.1	SM
2	L	266	13	Mirror,Outer R/C LT	Refinish				1.2	RF
					0.5 Surface					
					0.6 Two-stage setup					
					0.1 Two-stage					

Manual Entries										
3	SB			HAZARD. WSTE. REM.	Sublet Repair	\$3.00*				SM
3	Items									

MC	Message
13	INCLUDES 0.6 HOURS FIRST PANEL TWO-STAGE ALLOWANCE

Estimate Total & Entries

Gross Parts		\$180.05	
Paint & Materials	1.2 Hours @ \$40.00	\$48.00	
Parts & Material Total			\$228.05
Tax on Parts & Material	@ 5.500%		\$12.54

Labor	Rate	Replace Hrs	Repair Hrs	Total Hrs		
Sheet Metal (SM)	\$62.00	1.1		1.1	\$68.20	
Mech/Elec (ME)	\$80.00					
Frame (FR)	\$72.00					
Refinish (RF)	\$62.00	1.2		1.2	\$74.40	
Labor Total				2.3 Hours		\$142.60
Tax on Labor		@ 5.500%			\$7.84	
Sublet Repairs					\$3.00	
Tax on Sublet		@ 5.500%			\$0.17	
Gross Total						\$394.20
Net Total						\$394.20

Alternate Parts Y/00/00/00/00/00 CUM 00/00/00/00/00 Zip Code: 53081 Audatex Host
 OEM Part Prices DT 03/08/2019 11:33 AM EstimateID 533337611981299712 QuoteID ****
 Rate Name Default

Audatex Estimating 8.0.642 Update 3 ES 03/08/2019 11:38 AM REL 8.0.642 Update 3 DT 02/01/2019 DB 03/01/2019
 © 2019 Audatex North America, Inc.

0.7 HRS WERE ADDED TO THIS ESTIMATE BASED ON AUDATEX'S TWO-STAGE REFINISH FORMULA.

SHEBOYGAN COLLISION CENTER
CHEVROLET - BUICK - GMC - CADILLAC INC
3400 SOUTH BUSINESS DRIVE - SHEBOYGAN, WI 53081
OFFICE: 920-459-6855 FAX: 920-459-6286 TOLL FREE: 888-459-6855
FED I.D.# 83-0747810 EMAIL: COLLISIONCENTER@SHEBOYGANAUTO.COM

*** PRELIMINARY ESTIMATE ***

03/07/2019 10:46 AM

Owner

Owner: MARGARET BULKOW
Address: 125 S 2ND STREET
City State Zip: Oostburg, WI 53070

Home/Day: (920)564-5091
FAX:

Inspection

Inspection Date: 03/07/2019 10:45 AM
Inspection Location: Sheboygan Chev/Buick/GMC/Cad
Address: 3400 SOUTH BUSINESS DRIVE
City State Zip: SHEBOYGAN, WI 53081
Email: collisioncenter@sheboyganauto.com
Primary Impact: Left Side
Appraiser Name: Jeff Wiegand

Inspection Type: Drive In
Contact:
Work/Day: (920)459-6855x
Work/Day: (888)459-6855x
FAX: (920)459-6286x
Secondary Impact:
Appraiser License # :

Repairer

Repairer: Sheboygan Chev/Buick/GMC/Cad
Address: 3400 SOUTH BUSINESS DRIVE
City State Zip: SHEBOYGAN, WI 53081
Email: collisioncenter@sheboyganauto.com

Contact:
Work/Day: (920)459-6855
Work/Day: (888)459-6855
FAX: (920)459-6286

Target Complete Date/Time:

Days To Repair: 1

Vehicle

OEM Part Price Quote ID: ****

2012 Chevrolet Equinox 1LT 4 DR Wagon
6cyl Gasoline 3.0 Dohc
6-Speed Automatic

Lic.Plate: 150PLU
Lic Expire:
Prod Date: 03/2012
Veh Insp# :
Condition:

Ext. Color: SWITCHBLADE SILVER MET
Ext. Refinish: Two-Stage
Ext. Paint Code: 17,636R

Lic State: WI
VIN: 2GNFLEE52C6298878
Mileage: 56,261
Mileage Type: Actual
Code: U7714B
Int. Color: Yellow w/Yellow Trim w/Cloth
Seat Tri
Int. Refinish: Two-Stage
Int. Trim Code: AFJ

Options - AudaVIN Information Received

1st Row LCD Monitor(s)
AM/FM CD Player

2nd Row Head Airbags
Air Conditioning

4-Wheel Drive
Alarm System

All-Weather Mats (Floor)	Anti-Lock Brakes	Auto Headlamp Control
Auxiliary Audio Input	Bucket Seats	Center Console
Chromed Alloy Wheels	Cruise Control	Daytime Running Lights
Dual Airbags	Electric Steering	Emergency S.O.S. System
Halogen Headlights	Head Airbags	Heated Power Mirrors
Heated Rear Wiper Park	Heated W/S Wiper Washers	Illuminated Visor Mirror
Intermittent Wipers	Keyless Entry System	Leather Steering Wheel
Lighted Entry System	MP3 Decoder	Metallic Paint
Mud/Splash Guards	OnStar System	Power Brakes
Power Door Locks	Power Drivers Seat	Power Windows
Privacy Glass	Pwr Driver Lumbar Supp	Rear Spoiler
Rear Step Bumper	Rear View Camera	Rear Window Defroster
Rear Window Wiper/Washer	Remote Starter	Reverse Sensing System
Roof/Luggage Rack	Side Airbags	Skid Plates
Split Folding Rear Seat	Stability Cntrl Suspensn	Strg Wheel Radio Control
Tachometer	Theft Deterrent System	Tilt & Telescopic Steer
Tire Pressure Monitor	Touch Screen Display	Traction Control System
Trip Computer	Upgraded/Addl Speakers	Velour/Cloth Seats
Wireless Phone Connect	XM Satellite Radio	

AudaVIN options are listed in bold-italic fonts

Damages

Line	Op	Guide	MC	Description	MFR.Part No.	Price	ADJ%	B%	Hours	R	
Front Doors											
1	OE	266	46	Mirror,Outer R/C LT	Replace PXN OE Srpls	\$155.58			1.1	SM	
				>> RYDELL CHEVY OEM (800) 383-4601 >> 1325 E SAN MARNAN DR >> WATERLOO, IA, 50702 >> OEM SURPLUS >> 22818288 (DL8)							
2	L	266	13	Mirror,Outer R/C LT	Refinish				1.2	RF	
					0.5 Surface						
					0.6 Two-stage setup						
					0.1 Two-stage						

Manual Entries

3	SB			Hazardous Waste	Sublet Repair	\$5.00*				RF*
---	----	--	--	-----------------	---------------	---------	--	--	--	-----

MC	Message
13	INCLUDES 0.6 HOURS FIRST PANEL TWO-STAGE ALLOWANCE
46	PRINTABLE ALTERNATE PARTS COMPARE

Estimate Total & Entries

OE Surplus Parts		\$155.58	
Paint & Materials	1.2 Hours @ \$40.00	\$48.00	
Parts & Material Total			\$203.58
Tax on Parts & Material	@ 5.500%		\$11.20

Labor	Rate	Replace Hrs	Repair Hrs	Total Hrs	
Sheet Metal (SM)	\$60.00	1.1		1.1	\$66.00
Mech/Elec (ME)	\$120.00				
Frame (FR)	\$75.00				
Refinish (RF)	\$60.00	1.2		1.2	\$72.00

Labor Total		2.3 Hours		\$138.00
Tax on Labor	@ 5.500%		\$7.59	
Sublet Repairs			\$5.00	
Tax on Sublet	@ 5.500%		\$0.28	
Gross Total				\$365.65
Net Total				\$365.65

Alternate Parts Y/01/00/00/01/01 CUM 01/00/00/01/01 Zip Code: 53081 Default
 OEM Part Prices DT 03/07/2019 10:47 AM EstimateID 532963574067240960 QuoteID ****
 Recycled Parts NOT REQUESTED
 Rate Name Default

Audatex Estimating 8.0.643 ES 03/07/2019 10:54 AM REL 8.0.643 DT 02/01/2019 DB 03/01/2019
 © 2019 Audatex North America, Inc.

0.7 HRS WERE ADDED TO THIS ESTIMATE BASED ON AUDATEX'S TWO-STAGE REFINISH FORMULA.

THIS ESTIMATE HAS BEEN PREPARED BASED ON THE USE OF ONE OR MORE REPLACEMENT PARTS SUPPLIED BY A SOURCE OTHER THAN THE MANUFACTURER OF YOUR MOTOR VEHICLE. WARRANTIES APPLICABLE TO THESE REPLACEMENT PARTS ARE PROVIDED BY THE MANUFACTURER OR DISTRIBUTOR OF THE REPLACEMENT PARTS RATHER THAN BY THE MANUFACTURER OF YOUR MOTOR VEHICLE.

Op Codes

- | | | |
|----------------------------|---|--------------------------------|
| * = User-Entered Value | ^ = Labor Matches System Assigned Rates | E = Replace OEM |
| NG = Replace NAGS | EC = Replace Economy | OE = Replace PXN OE Srpls |
| UE = Replace OE Surplus | ET = Partial Replace Labor | EP = Replace PXN |
| EU = Replace Recycled | TE = Partial Replace Price | PM = Replace PXN Reman/Reblt |
| UM = Replace Reman/Rebuilt | L = Refinish | PC = Replace PXN Reconditioned |
| UC = Replace Reconditioned | TT = Two-Tone | SB = Sublet Repair |
| N = Additional Labor | BR = Blend Refinish | I = Repair |
| IT = Partial Repair | CG = Chipguard | RI = R & I Assembly |
| P = Check | AA = Appearance Allowance | RP = Related Prior Damage |



This report contains proprietary information of Audatex and may not be disclosed to any third party (other than the insured, claimant and others on a need to know basis in order to effectuate the claims process) without Audatex's prior written consent.

© 2019 Audatex North America, Inc.
 AUDATEX is a trademark owned by Audatex North America, Inc. All rights reserved.



II

R. O. No. _____ - 18 - 19. By CITY CLERK. March 18, 2019.

Submitting a communication from Harbor Centre Business Improvement District requesting that the City of Sheboygan release all funds collected on their behalf and those funds allocated to them for fiscal 2019.

CITY CLERK

Finance and Personnel



March 14, 2019

Common Council
City of Sheboygan
828 Center Avenue
Sheboygan, WI 53081

Dear Common Council,

The Harbor Centre Business Improvement District requests that the City of Sheboygan release all funds collected in our behalf and those funds allocated to us for fiscal 2019.

Thank you for your help in this matter.

Sincerely,

A handwritten signature in black ink, appearing to read "David O. Gass".

David O. Gass
President

A handwritten signature in black ink, appearing to read "John Motiska".

John Motiska
Executive Director

II

R. O. No. _____ - 18 - 19. By ASSISTANT FIRE CHIEF BUTLER. March 18, 2019.

Submitting the Annual Report for City of Sheboygan Fire Department for the year 2018.

ASSISTANT FIRE CHIEF CHARLES BUTLER

LHPS

2018

Annual Report



City of Sheboygan
Fire Department



Sheboygan Fire Department Annual Report | 2018



Thank you citizens, council and city leaders for supporting your Sheboygan Fire Department!

2018 was a great year for the department and the City of Sheboygan. We completed the year with no fire deaths and we improved our stations, apparatus and equipment to meet immediate and future needs. These improvements enhance services to our citizens on each and every medical or fire response.

We are proud of our 2018 accomplishments:

- Exceeded our 2017 ambulance revenue goal of \$1,200,000
- Completed our ambulance refurbishment program, saving \$240,000
- Won a federal health and wellness grant for \$98,000
- Received a State of Wisconsin award of \$87,000 for the successful completion of the 2016 fire inspection program
- Earned the highest satisfaction rating by citizens for fire and emergency medical service
- Successfully implemented the new emergency medical dispatch procedure
- Renovated training room with enhanced technology and a new department-wide teleconference system
- Initiated remodeling and repairs to our 112 year-old Fire Station 1
- Completed all architectural and engineering work for Station 2
- Added new electric extrication equipment
- Purchased two fire suppression tools with \$1,000 Kwik Trip grant
- Implemented new telecommunication system

Our mission is to provide quality professional services to those who live, work, invest, or visit our community. We accomplish this through the talent and commitment of the members of the Sheboygan Fire Department along with the leadership and support of our city leaders and the common council.

Yours in fire safety and prevention,

A handwritten signature in blue ink that reads "Mike Romas". The signature is written in a cursive style.

Mike Romas

Fire Chief

City of Sheboygan



Department Mission

The Sheboygan Fire Department is dedicated to serving all who live, visit, work and invest in the City of Sheboygan through excellence in fire protection, rescue, emergency and non-emergency medical services, code enforcement, and education, and at the highest professional level in a compassionate, ethical, and cost effective manner.

Courage * Honor * Integrity



Sheboygan Fire Department Annual Report | 2018

Sheboygan Fire Department Management and Administrative Staff



FIRE CHIEF – MICHAEL T. ROMAS
CHIEF OF THE DEPARTMENT



ASSISTANT CHIEF – VERNON KOCH



ASSISTANT CHIEF – CHARLES BUTLER



BATTALION CHIEF – PAT NICOLAUS
A SHIFT
EMS



BATTALION CHIEF – DEAN KLEIN
B SHIFT
SUPPORT SERVICES



BATTALION CHIEF – KEITH RISSE
C SHIFT
TRAINING



CONFIDENTIAL SECRETARY
LISA HORN



ADMINISTRATIVE ASSISTANT
JENNIFER ALBRIGHT



BATTALION CHIEF
ROBERT KOCMOUD

Sheboygan Fire Department Annual Report | 2018

Detailed Breakdown by Incident Type

INCIDENT TYPE	# INCIDENTS	% of TOTAL
111 - Building fire	48	0.89%
112 - Fires in structure other than in a building	1	0.02%
113 - Cooking fire, confined to container	5	0.09%
116 - Fuel burner/boiler malfunction, fire confined	1	0.02%
118 - Trash or rubbish fire, contained	3	0.06%
121 - Fire in mobile home used as fixed residence	1	0.02%
130 - Mobile property (vehicle) fire, other	1	0.02%
131 - Passenger vehicle fire	12	0.22%
132 - Road freight or transport vehicle fire	1	0.02%
134 - Water vehicle fire	1	0.02%
135 - Aircraft fire	1	0.02%
138 - Off-road vehicle or heavy equipment fire	1	0.02%
141 - Forest, woods or wildland fire	1	0.02%
142 - Brush or brush-and-grass mixture fire	1	0.02%
151 - Outside rubbish, trash or waste fire	8	0.15%
154 - Dumpster or other outside trash receptacle fire	5	0.09%
160 - Special outside fire, other	1	0.02%
162 - Outside equipment fire	2	0.04%
251 - Excessive heat, scorch burns with no ignition	36	0.67%
300 - Rescue, EMS incident, other	70	1.30%
311 - Medical assist, assist EMS crew	184	3.43%
320 - Emergency medical service, other	10	0.19%
321 - EMS call, excluding vehicle accident with injury	3769	70.20%
322 - Motor vehicle accident with injuries	117	2.18%
323 - Motor vehicle/pedestrian accident (MV Ped)	9	0.17%
324 - Motor vehicle accident with no injuries.	16	0.30%
331 - Lock-in (if lock out , use 511)	15	0.28%
342 - Search for person in water	1	0.02%
351 - Extrication of victim(s) from building/structure	1	0.02%
352 - Extrication of victim(s) from vehicle	3	0.06%
353 - Removal of victim(s) from stalled elevator	5	0.09%
361 - Swimming/recreational water areas rescue	2	0.04%
364 - Surf rescue	1	0.02%
381 - Rescue or EMS standby	17	0.32%
411 - Gasoline or other flammable liquid spill	11	0.20%
412 - Gas leak (natural gas or LPG)	26	0.48%
413 - Oil or other combustible liquid spill	14	0.26%
421 - Chemical hazard (no spill or leak)	1	0.02%
422 - Chemical spill or leak	31	0.58%
424 - Carbon monoxide incident	17	0.32%
440 - Electrical wiring/equipment problem, other	1	0.02%
441 - Heat from short circuit (wiring), defective/worn	4	0.07%
442 - Overheated motor	4	0.07%
443 - Breakdown of light ballast	4	0.07%
444 - Power line down	18	0.34%

Sheboygan Fire Department Annual Report | 2018

445 - Arcing, shorted electrical equipment	17	0.32%
451 - Biological hazard, confirmed or suspected	1	0.02%
463 - Vehicle accident, general cleanup	2	0.04%
500 - Service Call, other	3	0.06%
510 - Person in distress, other	1	0.02%
511 - Lock-out	51	0.95%
512 - Ring or jewelry removal	2	0.04%
520 - Water problem, other	3	0.06%
521 - Water evacuation	1	0.02%
522 - Water or steam leak	8	0.15%
531 - Smoke or odor removal	16	0.30%
542 - Animal rescue	14	0.26%
551 - Assist police or other governmental agency	33	0.61%
552 - Police matter	4	0.07%
553 - Public service	94	1.75%
554 - Assist invalid	110	2.05%
555 - Defective elevator, no occupants	1	0.02%
561 - Unauthorized burning	63	1.17%
571 - Cover assignment, standby, moveup	1	0.02%
600 - Good intent call, other	39	0.73%
611 - Dispatched & cancelled en route	56	1.04%
621 - Wrong location	1	0.02%
622 - No incident found on arrival at dispatch address	31	0.58%
631 - Authorized controlled burning	14	0.26%
651 - Smoke scare, odor of smoke	13	0.24%
652 - Steam, vapor, fog or dust thought to be smoke	6	0.11%
653 - Smoke from barbecue, tar kettle	2	0.04%
661 - EMS call, party transported by non-fire agency	6	0.11%
671 - HazMat release investigation w/no HazMat	25	0.47%
700 - False alarm or false call, other	1	0.02%
710 - Malicious, mischievous false call, other	2	0.04%
714 - Central station, malicious false alarm	10	0.19%
715 - Local alarm system, malicious false alarm	11	0.20%
730 - System malfunction, other	1	0.02%
731 - Sprinkler activation due to malfunction	12	0.22%
733 - Smoke detector activation due to malfunction	39	0.73%
734 - Heat detector activation due to malfunction	2	0.04%
735 - Alarm system sounded due to malfunction	44	0.82%
736 - CO detector activation due to malfunction	14	0.26%
740 - Unintentional transmission of alarm, other	2	0.04%
741 - Sprinkler activation, no fire - unintentional	5	0.09%
742 - Extinguishing system activation	2	0.04%
743 - Smoke detector activation, no fire - unintentional	53	0.99%
744 - Detector activation, no fire - unintentional	9	0.17%
745 - Alarm system activation, no fire - unintentional	52	0.97%
746 - Carbon monoxide detector activation, no CO	8	0.15%
911 - Citizen complaint	3	0.06%
TOTAL INCIDENTS:	5369	100.00%

Sheboygan Fire Department Annual Report | 2018

SHEBOYGAN FIRE DEPARTMENT TABLE OF ORGANIZATION

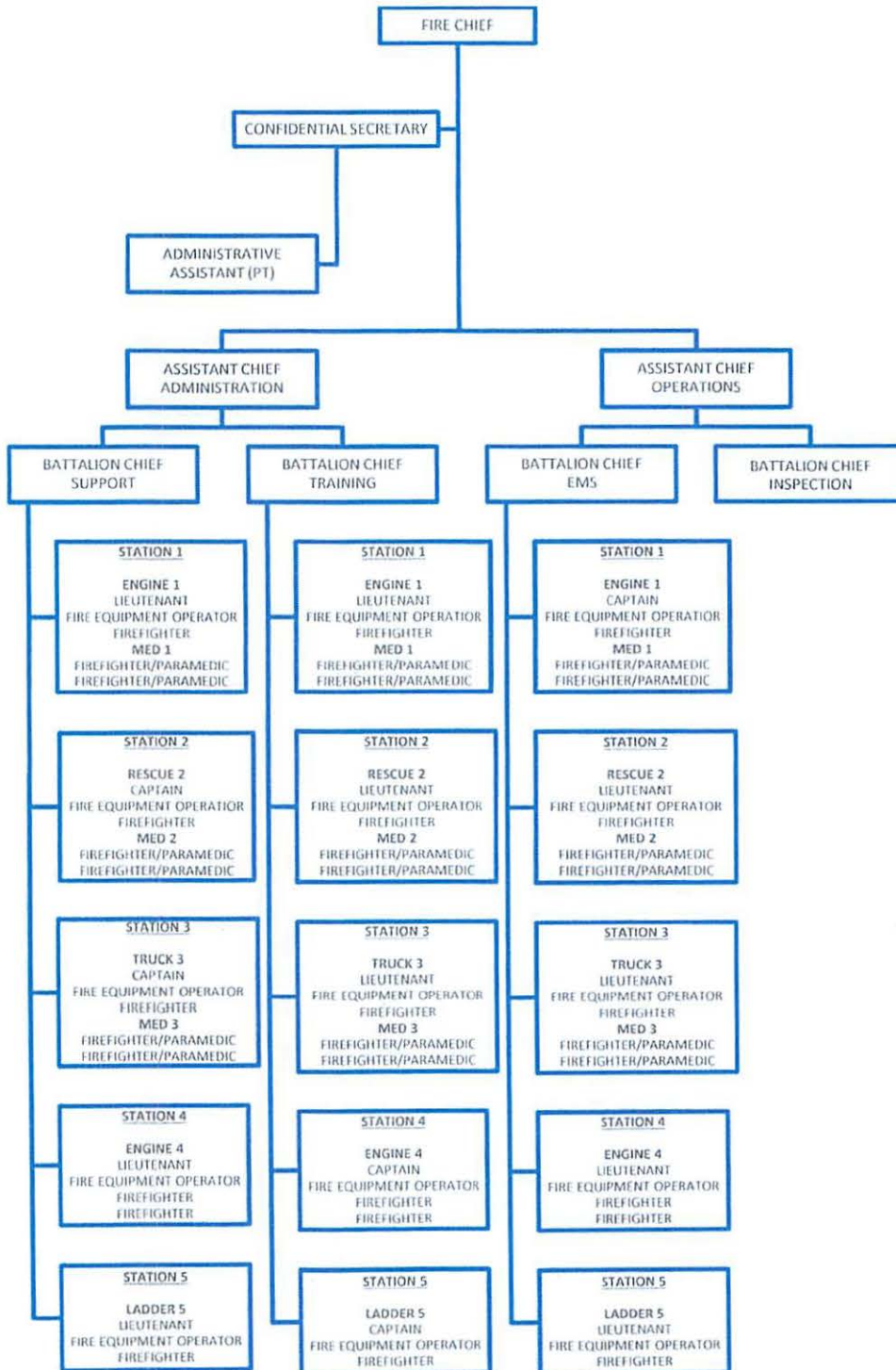

Sheboygan Fire Department Annual Report | 2018



Fire Station #1
833 New York Avenue
Engine 1
Med 1

Fire Station #2
2413 South 18th Street
Rescue 2
Med 2
Trench Rescue Trailer



Fire Station #3
1326 North 25th Street – Department Headquarters
Engine 3
Med 3
Battalion Chief Car

Fire Station #4
2622 North 15th Street
Ladder 4
Engine 6 (Reserve Engine)
Med 6 (Reserve Ambulance)



Fire Station #5
4504 South 18th Street
Ladder 5
Engine 7 (Reserve Engine)

Services Provided by the Sheboygan Fire Department

Fire Suppression and Rescue	Code Enforcement
Rope Rescue	Building Plan Review
Excavation Rescue	Fire Safety Training for Businesses
Confined Space Rescue	Medical Transports
Water/Ice Rescue	Public Service/Assistance
Automobile and Industrial Extrication	Hazardous Materials Response
Emergency Management	School Fire Safety Education
Advanced Life Support Response	Special Event Standby
Fire Safety Building Inspections	Fall Prevention Referrals
Smoke Alarm Installations	

Equipment, Facilities, and Vehicles Status Update

Equipment

- All cardiac monitors received preventative maintenance.
- All patient moving equipment, stair chairs and power cots received preventative maintenance.
- As part of a cancer mitigation program, the department continues to add additional sets of 10 new sets of personal protective gear so that each member has a second set while theirs is being cleaned between fires.
- Also as part of the cancer mitigation program a new extraction machine and a drying cabinet has been purchased to better remove contaminants from the personal fire gear. This process lessens the exposure to carcinogens in the by products of fires. Each apparatus also carries personal decon kits to be able to clean contaminants from skin as soon as possible after being exposed during fires.
- All ladders and pumps were tested to industry standards.
- All department fire hoses were inspected and pressure tested.

Apparatus

- In May of 2018 the department took delivery of a new Pierce Pumper now serving as E4.
- Delivery of a Pierce aerial ladder occurred in 2018 and will be placed into service in 2019 as Truck 3.

Buildings

- Work continues on Station #1 as part of a comprehensive maintenance and upgrade project.

Wellness Grant

An assistance to firefighters grant through FEMA was awarded to the Sheboygan Fire Department for the improvement and expansion of fitness and general wellness of the members of the fire department. This grant proposal is competitive and the department was fortunate to have their proposal funded. As a result of the grant, the department was able to contract with an outside fitness consultant, purchase a wide variety of exercise equipment for each station, train a core group of department members as fitness trainers, and also provide National Fire Protection Association compliant physicals for firefighters for the entire department. These physicals were designed specifically for the issues that are of concern for firefighters and the hazards they face on the job.

Response Statistics

Total Number of Responses

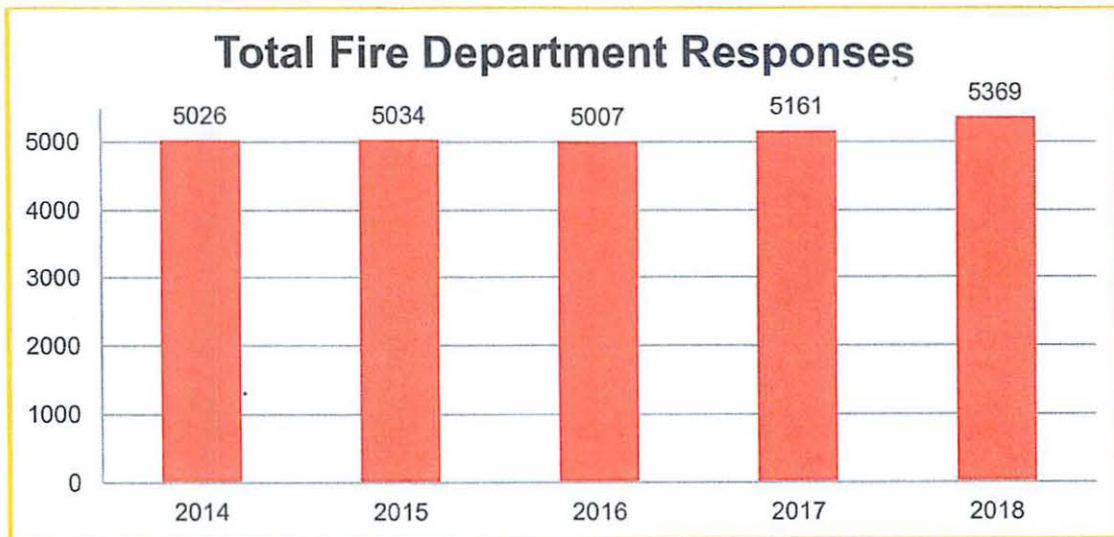

Types of Non EMS/Rescue Incidents

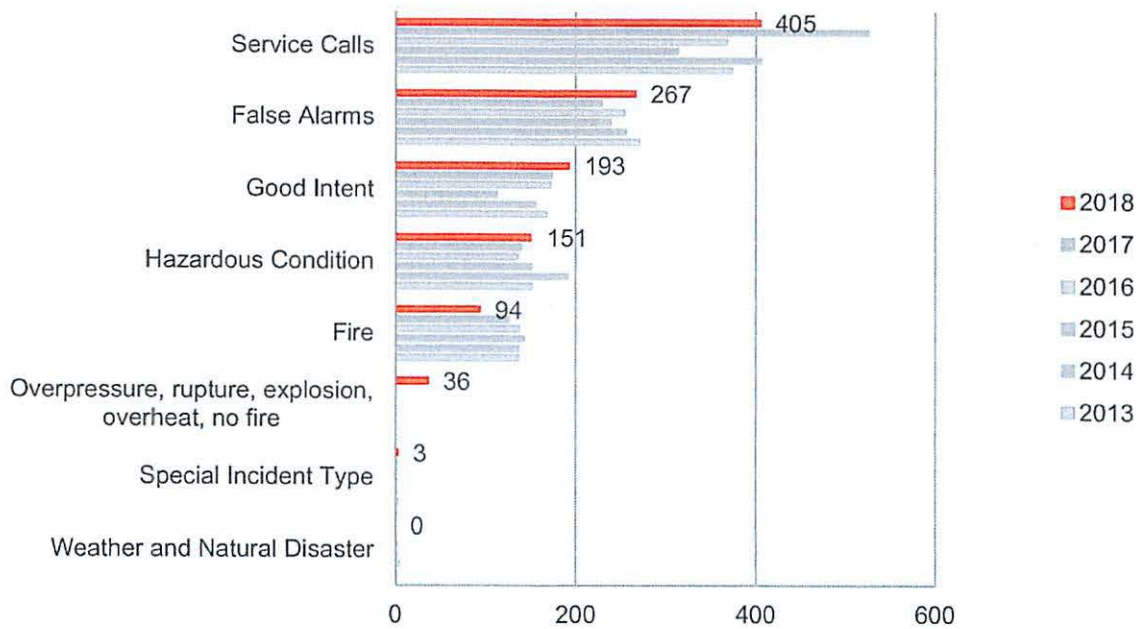

2018 Calls by Day of Week

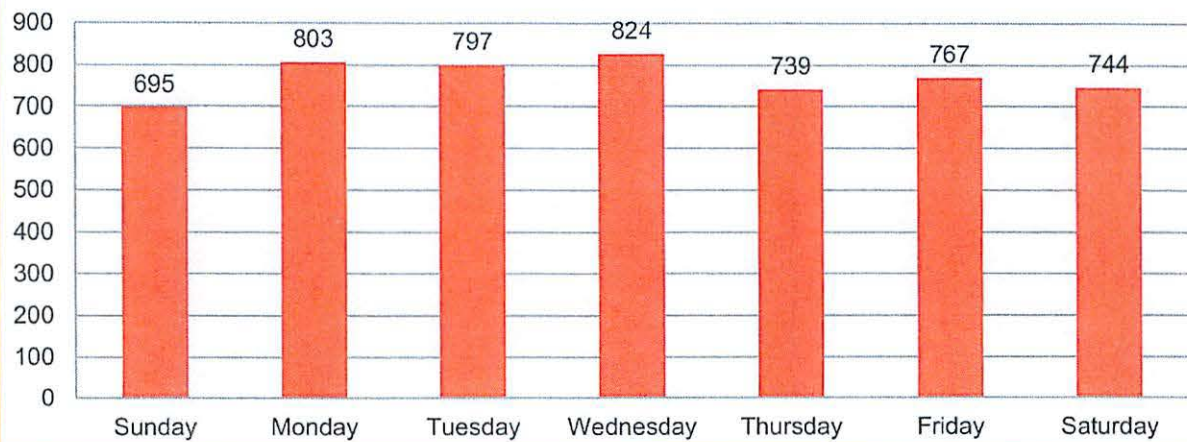

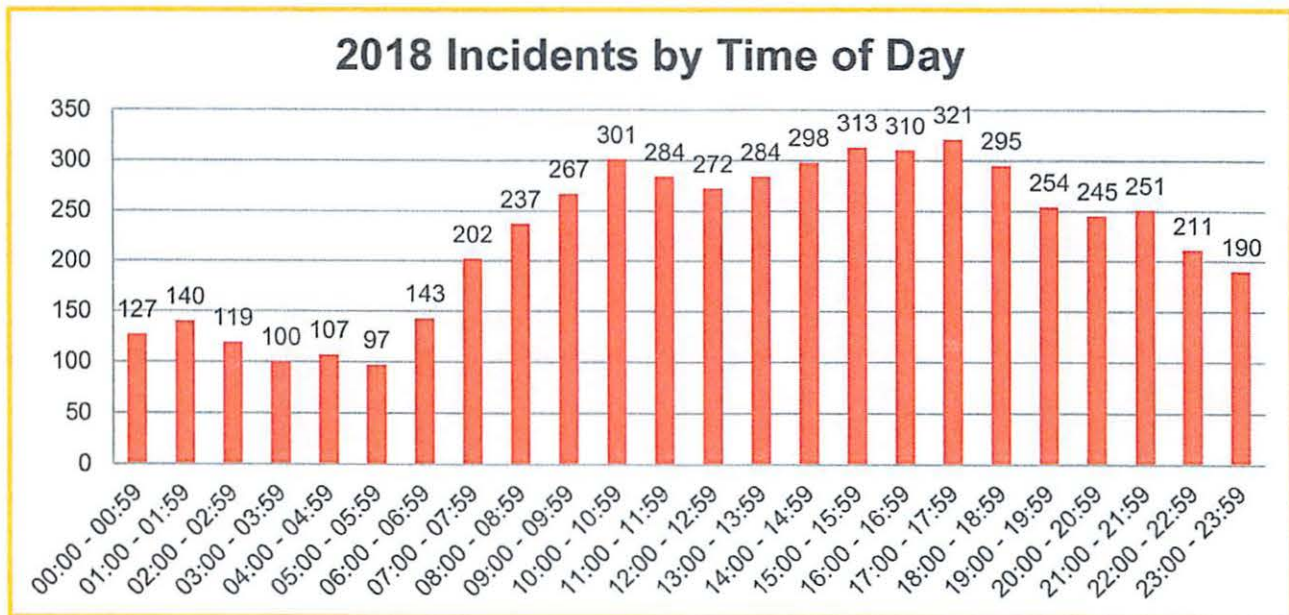

The *Calls by Day of Week* and *Calls by Time of Day* graphs are indicators of when requests for the Fire Department occur in Sheboygan. While there are some patterns that are seen, these graphs match trends nationally overall and also indicate that requests happen at all times.

Mutual Aid Given/Received

	2014	2015	2016	2017	2018
Total Responses Out of City	26	19	21	45	42
Incidents with Mutual Aid Provided	8	8	8	6	8
EMS and Other	18	11	13	39	34
Incidents with Mutual Aid Received	5	5	4	1	5

Fire Related Deaths

	2014	2015	2016	2017	2018
Fire Deaths	1	0	1	0	0

Concurrent Calls

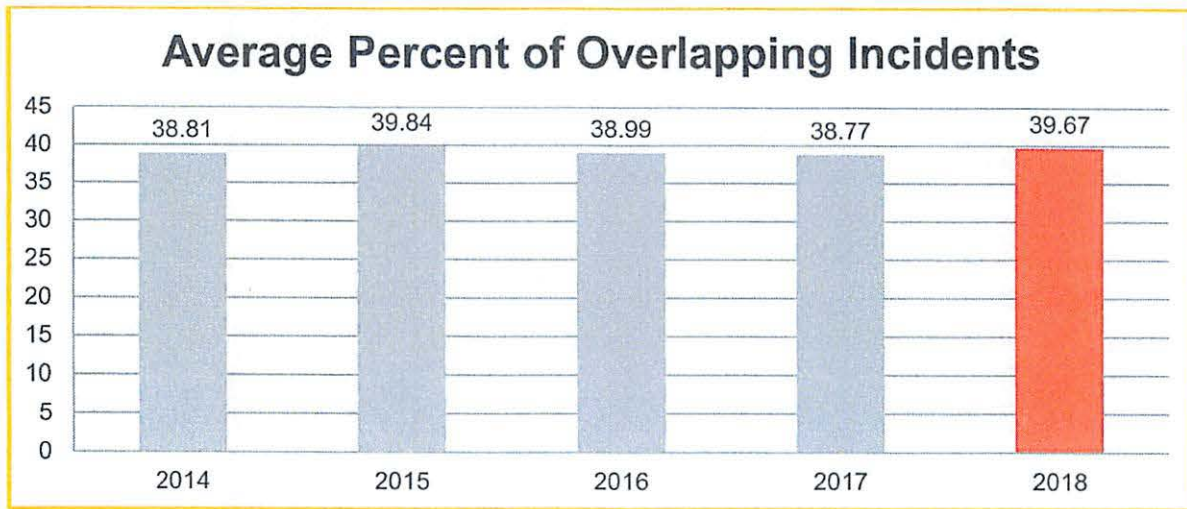

The measure of simultaneous calls represents the percentage of total call requests for the fire department while another call or multiple calls are already in progress. Generally speaking the call requests are random and in 2018 there was a slight increase in concurrent calls from the previous year, but that increase was insignificant and represented a relatively flat trend, which would suggest a relatively stable call volume overall with a consistent ability to handle the present call volume.

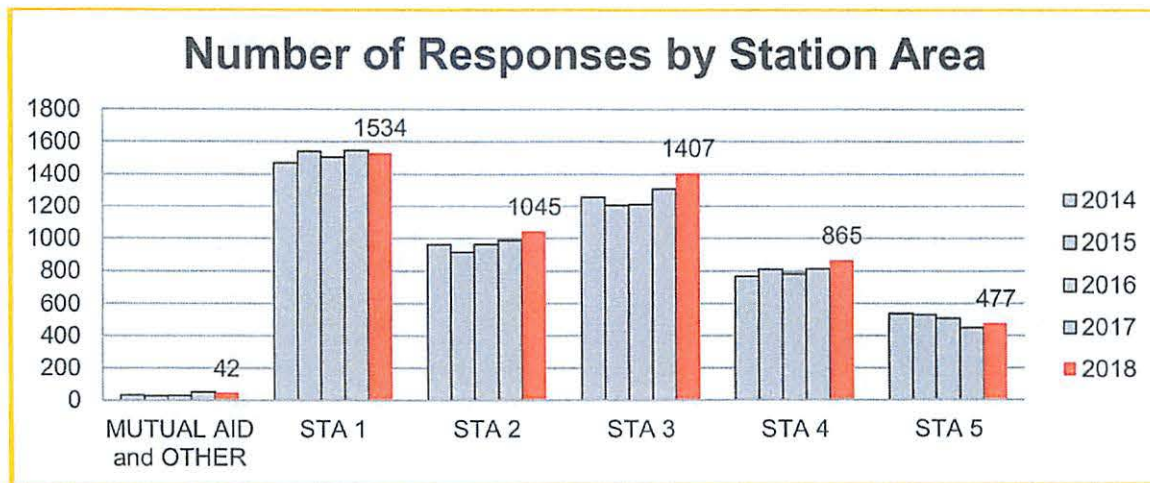

The *Response Requests by Station Area* graph is the total number of incidents as distributed by Fire Station Single Alarm response area as designated by the fire department. These response areas are established to maintain appropriate response times as set forth by the National Fire Protection Association (NFPA).



Emergency Medical Services

The Sheboygan Fire Department maintains a fleet of four ambulances for providing care and transport to the sick and injured. The department has continued to provide a quality, consistent, and compassionate service to the community.

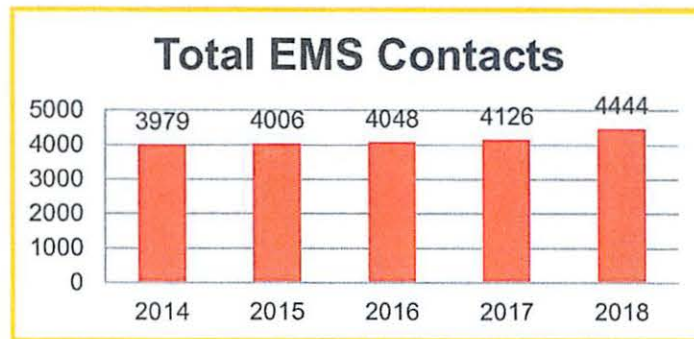

As a value-added service of the Fire Department, the revenues generated through the provision of the ambulance service aid in offsetting the cost of a effective and efficient fire department. This is done through the use of cross-trained personnel with a great deal of education and training and who are prepared to meet the emergency and non emergency needs of those it serves, whether it be a medical emergency, a fire, or another service need. Each ambulance vehicle also carries firefighting equipment for the firefighter/paramedics who staff those vehicles. This allows those personnel to also be able to respond to fires should they occur.

The Sheboygan Fire Department is interested in preventing injury that might cause need for someone to use an ambulance. As part of our injury prevention efforts, we have partnered with the Aging and Disability Resource Center (ADRC) in assisting with a referral program that provides for education and support from the ADRC for those who may need assistance or education about preventing falls in the home. When it is recognized through our contact, that a person might be in need of assistance or support, our crews will offer the referral and we will make contact with the ADRC to have them make contact with the individual and offer assistance. Our goal is to encourage every ambulance service in the county to provide this service and connection to the resources they need.

The Sheboygan Fire Department also is a key member of the recently created Dementia Crisis Care Task Force of Sheboygan County. It is the goal of this task force to improve all aspects of care to persons with dementia and in particular those who are suffering a crisis. The task force has focused on evaluating the current system in place for managing crisis situations, formulating improved, collaborative approaches to better manage those situations, and is providing county-wide education and changes to how these types of calls are being handled.

Fire Prevention and Public Education



In an effort to reduce the loss of life, injury, and property loss in the City of Sheboygan, the Sheboygan Fire Department is dedicated to providing education to the public as part of its mission.

While it is a core mission of the Sheboygan Fire Department to respond to and mitigate incidents in the City of Sheboygan, it is also the department's mission to reduce the number and severity of those incidents by proper code development and enforcement, effective and efficient response, and ongoing public education. It is through this continuous and comprehensive program of education that the

department maintains a culture of safety in the community.

As fire hazards presented to the public change, so will the program offerings to the public. It is the department's intent to keep educating the public to specific life hazards such as discarding (tossing) cigarettes in or outside of an occupancy and or removing fire safety equipment in an apartment space such as smoke detectors.

This general program area of public education is vital to the success of the fire department mission. The funding for the materials used for the school programs are largely generated through a program developed and operated by the National Fire Safety Council (NFSC). Each year, local businesses are solicited for donations toward the program by NFSC on the department's behalf and those funds are used by the department to purchase all of the fire prevention materials used in the public education programs delivered in the schools. We sincerely thank those who contribute to these funds and to this mission.

Using NFPA 1, the use operation and maintenance of all commercial buildings where employees work, and or the public has access and all common areas of 3 family or larger apartment complexes are inspected at least once in a calendar year. The Sheboygan Fire Department uses occupancy records software that tracks annual fire inspections and sends by email any code deficiencies to the owner or occupant. The software also keeps track of building preplan information such as type of occupancy, number of apartment units, chemical storage onsite and types of fire suppression equipment in a building.

Working with the Building and Planning Departments all new construction has a pre occupancy inspection while construction occurs and as fire systems come online in a building. After occupancy, a preplan of the building takes place noting all fire service equipment, utility shutoffs and chemical locations and type of construction are noted and added to our occupancy software. This information is held for the life of the building and is available for pre-incident planning as well as onsite mitigation during an incident.



FAMILIES PARTICIPATE IN ACTIVITY GAME
DESIGNED AND BUILT BY DEPARTMENT MEMBER

Training and Resource Development

The nature of the responsibilities of a fire department requires continuous training of its personnel to assure the best possible chance of a positive outcome when critical incidents occur. This is especially important when those events do not happen very often and you get one chance to get it right. Training and preparation is tailored to create effectiveness, efficiency, and safety when the fire department responds to incidents. The Sheboygan Fire Department provides for training of its employees through many different programs using a variety of methodologies that are designed to best meet the needs of the department both fiscally and operationally. Because of the inherent dangers present in the job, many of the training areas are statutorily mandated for the protection of both the employee and the citizens they serve.

In 2018, a focused effort was made on increasing training and education for Company Officers. This training covered items such as general leadership training, human resource and personnel skills, general supervisory skills, crew readiness, incident management, and many other topics designed to improve relationships and response and to decrease risk to personnel, the public, and to the City. That emphasis is reflected in the large administrative training category.

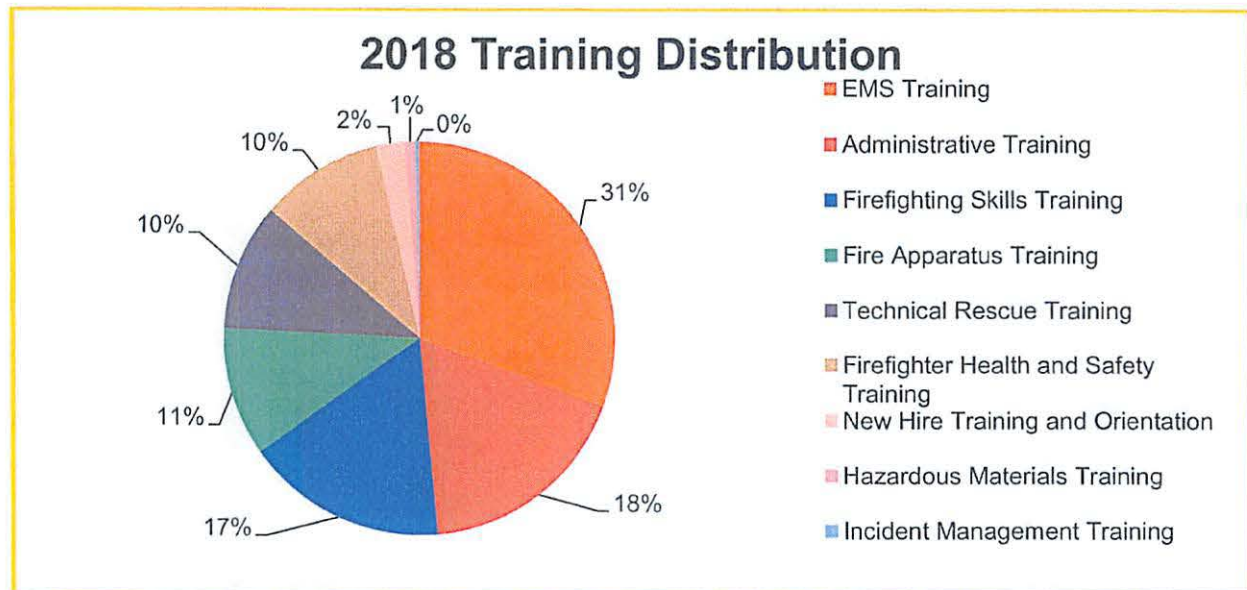

CATEGORY	TOTAL HOURS
Emergency Medical Services Training	3166
Administrative Training	1849
Firefighting Skills Training	1714
Fire Apparatus Training	1090
Technical Rescue Training	1089
Firefighter Health and Safety Training	1051
New Hire Training and Orientation	246
Hazardous Materials Training	86
Incident Management Training	34
TOTAL TRAINING HOURS	10325

Retirements in 2018



ASSISTANT CHIEF
VERNON KOCH



LIEUTENANT
BLAINE WERNER



FEO
KURT SPATT



FEO
MICHAEL TOTH



FEO
TODD McLAUGHLIN



FEO
JOSEPH RAML



FEO
MARK ZEMKE

Promotions in 2018



CAPTAIN
JEFFERY SALZMAN



LIEUTENANT
KURT MILLER

New Employees



FIREFIGHTER/PARAMEDIC
STEVEN BOYLE



FIREFIGHTER/PARAMEDIC
ANTHONY WENZEL



FIREFIGHTER/PARAMEDIC
KYLE WAM

New Hire Training

When newly hired personnel enter the Sheboygan Fire Department, it is important for the department to get them up to speed and into their day-to-day positions as soon as possible. It is also critical to their performance and safety that they are properly familiarized with their assignments and how to perform them according to the standards and expectations of the department.

The training division of the fire department works diligently to assure that these new firefighters have all of the tools necessary to perform their jobs. New firefighters are given intensive department familiarization through a year-long probationary period that begins with 3 weeks of direct instruction on 8 hour days prior to moving on to the 24 hour duty rotation. They are issued gear, brought up to speed on pertinent policies and procedures, tested on their driving performance for ambulance vehicles, their medical care and their firefighting skills, and even tested on historical facts and background on the fire department. All of this helps to build a sense of team and family as a member of the Sheboygan Fire Department.

Everyone coming into the department has education, certifications, and licenses as a condition of hire, but it is up to the department to verify that information and skill set and to expand that knowledge with department-specific information related to their new employment prior to placing them in the field providing medical care and entering hazardous situations.



In Memoriam



Vilas Vreeke

Born:
Appointed: 1964
Retired: 1991
Retired as a Fire Equipment Operator
Returned to Quarters: 2018



Thomas Murray

Born:
Appointed: 1961
Retired: 1990
Retired as a Lieutenant
Returned to Quarters: 2018

**“What we do for ourselves dies with us. What we do for others and
the world remains and is immortal.”**

Albert Pine

III

Res. No. _____ - 18 - 19. By Alderpersons Rindfleisch and Bohren.
March 18, 2019.

A RESOLUTION authorizing the City of Sheboygan to enter into a contract with Municipal Property Insurance Company (MPIC) for building and property insurance coverage.

WHEREAS, state law and the City's Procurement Policy allows the City to join with other purchasing associations in cooperative purchasing plans when the best interest of the City would be served; and

WHEREAS, the Municipal Property Insurance Company (MPIC) was formed by three municipal insurance companies - Wisconsin Municipal Mutual Insurance Company, Cities and Villages Mutual Insurance Company, and the League of Wisconsin Municipal Mutual Insurance Company - to provide a stable, long-term solution for property insurance for Wisconsin local government entities; and

WHEREAS, the City currently obtains its building and property insurance coverage from MPIC; and

WHEREAS, the City has obtained a quote from MPIC for building and property insurance coverage to renew that coverage for the period from June 1, 2019 through May 31, 2020; and

WHEREAS, Staff believes that this cost is reasonable in light of the buildings and properties being insured.

NOW, THEREFORE, BE IT RESOLVED: That the appropriate City Officials are hereby authorized to execute a contract with the Municipal Property Insurance Company (MPIC) to provide building and property insurance coverage to the City for the period from June 1, 2019 through May 31, 2020, pursuant to a contract substantially similar to the one attached, at a cost not to exceed One Hundred Thirty Thousand Dollars (\$130,000.00).

Finance and Personnel

BE IT FURTHER RESOLVED: That the appropriate City officials are hereby authorized to draw orders on the Prepaid Insurance Account No. 705-155010, in payment of same.

I HEREBY CERTIFY that the foregoing Resolution was duly passed by the Common Council of the City of Sheboygan, Wisconsin, on the _____ day of _____, 20____.

Dated _____ 20____. _____, City Clerk

Approved _____ 20____. _____, Mayor



MUNICIPAL PROPERTY INSURANCE COMPANY

9701 Brader Way, Suite 301, Middleton, WI 53562 - (608) 821-6303

RENEWAL POLICY QUOTE

Policy # 5000130_Q-1

Agent Pallin Allen

Named Insured and Principal Address:

City of Sheboygan
828 Center Avenue
Sheboygan, WI 53081-4497

Contact:

Marty Halverson
920-459-3882

Policy Period: 12:01 am 06/01/2019 to 06/01/2020

Coverage	Deductible	TIV	Rate	Annual Premium
Buildings, Personal Property & Property in the Open	5,000	214,026,961	0.0537	114,928
Contractors Equipment	1,000	6,515,257	0.192	12,509
Contractors Equipment valued under \$25,000	1,000	791,087	N/A	0
Monies & Securities	1,000	17,000	0.50	85
Pier and Wharf Limited Coverage		6,716	0.40	50
Specific Limit Coverage	5,000	100,000	0.0724	72
Vacancy Permit	5,000	285,000	0.029	83
Total Annual Premium		\$127,727		

Comments

This quote is your estimated renewal policy premium amount with coverages and coverage amounts as shown.

This quote becomes null and void within 30 days of transaction effective date.



MUNICIPAL PROPERTY INSURANCE COMPANY

9701 Brader Way, Suite 301, Middleton, WI 53562 - (608) 821-6303

DECLARATIONS

Policy # 5000130_Q-1

Replaces Policy # 240090

Agent Pallin Allen

Item I. Named Insured and Principal Address: Contact:
 City of Sheboygan Marty Halverson
 828 Center Avenue
 Sheboygan, WI 53081-4497 920-459-3882

Item II. Policy Period:

This Policy takes effect at 12:01 A.M., 06/01/2019, and expires at 12:01 A.M., 06/01/2020.

These effective and expiration times are based upon the local times at the principal address of the first named insured stated in Item I. above.

Item III. Coverages:

Coverage	Deductible	TIV	Rate	Annual Premium
Buildings, Personal Property & Property in the Open	5,000	214,026,961	0.0537	114,928
Contractors Equipment	1,000	6,515,257	0.192	12,509
Contractors Equipment valued under \$25,000	1,000	791,087	N/A	0
Monies & Securities Schedule Attached	1,000	17,000	0.50	85
Pier and Wharf Limited Coverage Schedule Attached		6,716	0.40	50
Specific Limit Coverage Schedule Attached	5,000	100,000	0.0724	72
Vacancy Permit Schedule Attached	5,000	285,000	0.029	83

Total Annual Premium \$127,727 Billed to Insured

Item IV. Forms and Endorsements made part of this policy at time of issue:

Form	Edition Date	Description
MPIC-001	01-2019	Municipal Property Insurance Company Policy
MPIC-004	06-2016	Statement of Values
MPIC-004 CE	06-2016	Contractor's Equipment
MPIC-004 PITO	06-2016	Property in the Open
MPIC-103	06-2016	Specific Limit Endorsement

MPIC-104	06-2016	Vacancy Permit
MPIC-201	06-2016	Monies & Securities Endorsement
MPIC-204	09-2018	Pier and Wharf Limited Coverage Endorsement
MPIC-300	01-2018	Contractor's Equipment Endorsement
MPIC-500	06-2016	Joint Loss Agreement Endorsement
MPIC-502	06-2016	Cap on Losses From Certified Acts of Terrorism
MPIC-506	06-2016	Coverage of Computer-Related Losses Endorsement
MPIC-510	01-2019	Tax Lien Property Coverage
MPIC-511	01-2019	Leased Property Coverage

Item V. Loss Payees:

Item VI. Variable Coverage Schedules:

Monies & Securities		
City Hall		17,000
		17,000
Pier and Wharf Limited Coverage		
HARBOR CENTRE MARINA - FLOATING DOCK		6,716
		6,716
Vacancy Permit		
Social Security Building - Vacancy Permit		285,000
		285,000
Specific Limit Coverage		
1920 Stahl Rd., Sheboygan, WI 53081 - Poth Farm		100,000
		100,000

STATEMENT OF VALUES

MUNICIPAL PROPERTY INSURANCE COMPANY

Coverage Amount - 214,026,961

Site	Bldg	Description	Year Built	Floors	Square Footage	Building CRN	Content CRN
1		CITY HALL					
	1	CITY HALL 828 Center Avenue Sheboygan WI 53081	1914	4	25,774	\$11,440,000	\$1,799,965
	2	CITY HALL GARAGE 828 CENTER AVENUE Sheboygan WI 53081	1914	1	6,238	\$368,022	\$185,985
	3	POLICE GARAGE 1315 North 23rd Street Sheboygan WI 53081	2008	1	10,719	\$702,860	\$474,767
	4	POLICE STATION 1211 N 23rd Street Sheboygan WI 53081	2008	1	33,746	\$7,272,072	\$1,588,204
		Property in the open					\$12,913
		CITY HALL (1) Total				\$19,782,954	\$4,061,834
2		FIRE ENGINE HOUSE 1					
	1	FIRE ENGINE HOUSE 1 833 New York Avenue Sheboygan WI 53081	1907	2	13,664	\$2,818,716	\$264,700
		FIRE ENGINE HOUSE 1 (2) Total				\$2,818,716	\$264,700
3		FIRE ENGINE HOUSE 2					
	1	FIRE ENGINE HOUSE 2 2413 South 18th Street Sheboygan WI 53081	1960	1	6,605	\$1,386,495	\$423,521
		FIRE ENGINE HOUSE 2 (3) Total				\$1,386,495	\$423,521
4		FIRE ENGINE HOUSE 3					
	1	FIRE ENGINE HOUSE 3 1326 N. 25th Street Sheboygan WI 53081	1971	2	33,077	\$6,439,687	\$1,588,204
	2	TRAINING FACILITY 1326 NORTH 25TH STREET Sheboygan WI 53081	2000	1	3,100	\$372,953	\$0
		Property in the open					\$809
		FIRE ENGINE HOUSE 3 (4) Total				\$6,812,640	\$1,589,013
5		FIRE STATION # 5					
	1	FIRE STATION # 5 4504 SOUTH 18TH STREET Sheboygan WI 53081	2006	1	7,005	\$850,965	\$308,035
		FIRE STATION # 5 (5) Total				\$850,965	\$308,035
6		PLAZA 8 FOUNTAIN					
	1	PLAZA 8 FOUNTAIN 700 BLOCK OF 8TH	1975	1	540	\$72,454	\$0

STATEMENT OF VALUES

MUNICIPAL PROPERTY INSURANCE COMPANY

Coverage Amount - 214,026,961

Site	Bldg	Description	Year Built	Floors	Square Footage	Building CRN	Content CRN
		Sheboygan WI 53081					
		PLAZA 8 FOUNTAIN (6) Total				\$72,454	\$0
7		FOUNTAIN PARK					
	1	FOUNTAIN PARK BANDSHELL ERIE AVENUE AND NORTH 9TH STREET Sheboygan WI 53081	1915	1	2,246	\$368,022	\$11,088
	2	FOUNTAIN PARK FOUNTAIN ERIE AVENUE AND NORTH 9TH STREET Sheboygan WI 53081	1915	1	84	\$48,303	\$1,756
		FOUNTAIN PARK (7) Total				\$416,325	\$12,844
8		END PARK					
	1	COMFORT STATION 13TH STREET AND LOS ANGELES AVENUE Sheboygan WI 53081	2003	1	513	\$186,841	\$2,609
	2	SHELTER 13TH AND LOS ANGELES AVENUE Sheboygan WI 53081	2005	1	1,140	\$143,627	\$1,789
		END PARK (8) Total				\$330,468	\$4,398
9		ROOSEVELT PARK					
	1	LIGHT CONTROL HOUSE S. 11TH ST & MEAD AVENUE Sheboygan WI 53081	1980	1	80	\$12,077	\$872
	2	SHELTER HOUSE SOUTH 12TH & MEAD AVENUE Sheboygan WI 53081	1980	1	2,040	\$274,069	\$20,101
		Property in the open					\$865,287
		ROOSEVELT PARK (9) Total				\$286,146	\$886,260
10		COLE PARK					
	1	COMFORT STATION NORTH 4TH AND NORTH 3RD STREET Sheboygan WI 53081	1980	1	408	\$57,179	\$2,182
		COLE PARK (10) Total				\$57,179	\$2,182
11		DELAND PARK					
	1	BEACH HOUSE 825 BROUGHTON DRIVE Sheboygan WI 53081	1985	1	4,831	\$838,053	\$21,096
	2	FISH CLEANING STATION/COMFORT BROUGHTON DRIVE	1980	1	801	\$125,421	\$4,585

STATEMENT OF VALUES

MUNICIPAL PROPERTY INSURANCE COMPANY

Coverage Amount - 214,026,961

Site	Bldg	Description	Year Built	Floors	Square Footage	Building CRN	Content CRN
		Sheboygan WI 53081					
	3	GROUP PICNIC SHELTER 833 BROUGHTON DRIVE Sheboygan WI 53081	1985	1	648	\$73,799	\$9,245
	4	SOUTH SHELTER - DELAND HOME BROUGHTON DRIVE Sheboygan WI 53081	1920	1	1,320	\$184,242	\$22,638
		Property in the open					\$788,147
		DELAND PARK (11) Total				\$1,221,515	\$845,711
12		KING PARK					
	1	PARK PAVILION 1601 S 7TH ST Sheboygan WI 53081	2009	1	1,900	\$734,594	\$7,616
	2	SHELTER LAKESHORE DR AND BROADWAY Sheboygan WI 53081	1934	1	913	\$126,970	\$4,147
		KING PARK (12) Total				\$861,564	\$11,763
13		VOLLRATH PARK					
	1	COMFORT STATION PARK AVENUE AND 2ND STREET Sheboygan WI 53081	1980	1	1,485	\$196,950	\$2,402
	2	CONCESSION STAND PARK AVENUE AND NORTH 2ND STREET Sheboygan WI 53081	1980	1	500	\$36,530	\$9,732
	3	ELECTRIC SWITCH HOUSE PARK AVENUE AND 2ND STREET Sheboygan WI 53081	1980	1	100	\$15,174	\$1,316
		Property in the open					\$1,205,979
		VOLLRATH PARK (13) Total				\$248,654	\$1,219,429
14		LAKE VIEW PARK					
	1	COMFORT STATION LAKESHORE DR AND SHOOTING PARKRD Sheboygan WI 53081	1980	1	560	\$76,235	\$3,057
	2	SHELTER HOUSE LAKESHORE DR AND SHOOTING PARKRD Sheboygan WI 53081	1912	1	1,176	\$162,007	\$5,240
		LAKE VIEW PARK (14) Total				\$238,242	\$8,297
15		EVERGREEN PARK					
	1	AREA #1 COMFORT STATION HIGHWAY 42	2001	1	1,500	\$307,387	\$0

STATEMENT OF VALUES

MUNICIPAL PROPERTY INSURANCE COMPANY

Coverage Amount - 214,026,961

Site	Bldg	Description	Year Built	Floors	Square Footage	Building CRN	Content CRN
		Sheboygan WI 53081					
	2	BAR STAND-AREA 1 HWY 42 Sheboygan WI 53081	1917	1	668	\$43,352	\$14,714
	3	COMFORT STATION AREA 2 HWY 42 Sheboygan WI 53081	1980	1	800	\$71,476	\$4,434
	4	COMFORT STATION AREA 4 & 5 HWY 42 Sheboygan WI 53081	1980	1	656	\$90,530	\$2,839
	5	COMFORT STATION/CONCESSION- ARE HWY 42 Sheboygan WI 53081	1974	1	481	\$66,707	\$2,662
	6	SHELTER HOUSE-AREA 5 HWY 42 Sheboygan WI 53081	1917	1	846	\$117,532	\$3,762
	7	TOOL HOUSE-AREA 1 HWY 42 Sheboygan WI 53081	1950	1	192	\$9,529	\$2,622
		Property in the open					\$31,857
		EVERGREEN PARK (15) Total				\$706,513	\$62,890
16		JAYCEE PARK					
	1	AREA #8 COMFORT STATION/SHELTER KIWANIS PARK DRIVE Sheboygan WI 53081	2000	1	720	\$193,423	\$0
	2	QUARRY BATH HOUSE BUS 42 N. AND CALUMET DRIVE Sheboygan WI 53081	1979	1	3,854	\$628,467	\$33,852
		Property in the open					\$807,449
		JAYCEE PARK (16) Total				\$821,890	\$841,301
17		KIWANIS PARK					
	1	COMFORT STATION KIWANIS PARK DRIVE Sheboygan WI 53081	1980	1	1,350	\$120,707	\$6,111
	2	CONCESSION STAND KIWANIS PARK DRIVE Sheboygan WI 53081	1980	1	558	\$41,295	\$11,883
	3	FIELD HOUSE KIWANIS PARK DRIVE Sheboygan WI 53081	1924	1	4,680	\$782,043	\$101,872
	4	SHELTER HOUSE UNION AVENUE AND SOUTH 22ND	1946	1	1,133	\$184,643	\$24,372

STATEMENT OF VALUES

MUNICIPAL PROPERTY INSURANCE COMPANY

Coverage Amount - 214,026,961

Site	Bldg	Description	Year Built	Floors	Square Footage	Building CRN	Content CRN
		ST Sheboygan WI 53081					
		Property in the open					\$22,472
		KIWANIS PARK (17) Total				\$1,128,688	\$166,710
18		MUNICIPAL SERVICE SITE					
	1	MUNICIPAL SERVICE BUILDING 2026 New Jersey Avenue Sheboygan WI 53081	1965	1	125,346	\$16,796,444	\$3,705,811
	2	POLICE IMPOUND GARAGE 2026 NEW JERSEY AVENUE Sheboygan WI 53081	1990	1	5,400	\$356,668	\$22,969
		MUNICIPAL SERVICE SITE (18) Total				\$17,153,112	\$3,728,780
19		MUNICIPAL ARMORY					
	1	MUNICIPAL ARMORY 516 Broughton Drive Sheboygan WI 53081	1920	2	47,900	\$9,346,458	\$635,281
		MUNICIPAL ARMORY (19) Total				\$9,346,458	\$635,281
20		CLEVELAND PARK					
	1	Park Open Pavilion 2321 Geele Ave Sheboygan WI 53081	2013	1	864	\$74,204	\$10,928
	2	Restroom Facility 2321 Geele Ave Sheboygan WI 53081	2013	1	420	\$79,461	\$6,072
	3	SHELTER HOUSE NORTH 25TH AND GEELE AVENUE Sheboygan WI 53081	1956	1	1,128	\$157,237	\$6,422
		Property in the open					\$7,747
		CLEVELAND PARK (20) Total				\$310,902	\$31,169
21		WILDWOOD BASEBALL COMPLEX					
	1	COMFORT STATION 22ND & NEW JERSEY Sheboygan WI 53081	1980	1	897	\$115,949	\$5,091
	2	Concessions, Rest Room Building 2328 Wildwood Ave Sheboygan WI 53081	1981	0	520	\$60,676	\$0
	3	Dugout 2328 Wildwood Ave Sheboygan WI 53081	2011	1	250	\$33,977	\$0
	4	Dugout 2328 Wildwood Ave Sheboygan WI 53081	2011	1	250	\$33,977	\$0

STATEMENT OF VALUES

MUNICIPAL PROPERTY INSURANCE COMPANY

Coverage Amount - 214,026,961

Site	Bldg	Description	Year Built	Floors	Square Footage	Building CRN	Content CRN
	5	GARAGE 2328 Wildwood Ave Sheboygan WI 53081	1970	1	520	\$19,059	\$2,842
	6	Garage 2328 Wildwood Ave Sheboygan WI 53081	2000	1	484	\$12,135	\$0
	7	Pavillion 2328 Wildwood Ave Sheboygan WI 53081	1990	1	400	\$2,427	\$0
	8	Press Box/Skybox 2328 Wildwood Ave Sheboygan WI 53081	1997	2	1,280	\$182,030	\$0
	9	Storage Shed 2328 Wildwood Ave Sheboygan WI 53081	1998	1	96	\$2,427	\$0
		Property in the open					\$372,895
		WILDWOOD BASEBALL COMPLEX (21) Total				\$462,657	\$380,828
22		NELESEN'S FISH					
	1	NELESEN'S FISH 715 S FRANKLIN Sheboygan WI 53081	1948	1	1,250	\$55,589	\$0
		NELESEN'S FISH (22) Total				\$55,589	\$0
23		ROTARY RIVERVIEW PARK					
	1	COMFORT STATION FRANKLIN STREET Sheboygan WI 53081	1980	1	400	\$60,387	\$2,182
		Property in the open					\$303,709
		ROTARY RIVERVIEW PARK (23) Total				\$60,387	\$305,891
24		WILDWOOD CEMETERY					
	1	GARAGE WILDWOOD AVENUE Sheboygan WI 53081	1920	1	1,920	\$96,003	\$61,941
	2	STORAGE BUILDING EVANS AVENUE Sheboygan WI 53081	1980	1	1,071	\$58,839	\$14,756
		WILDWOOD CEMETERY (24) Total				\$154,842	\$76,697
25		MAYWOOD					
	1	BARN 3615 MUELLER ROAD Sheboygan WI 53081	1950	1	1,500	\$111,181	\$20,767
	2	EQUIPMENT SHED	1980	1	556	\$71,476	\$7,651

STATEMENT OF VALUES

MUNICIPAL PROPERTY INSURANCE COMPANY

Coverage Amount - 214,026,961

Site	Bldg	Description	Year Built	Floors	Square Footage	Building CRN	Content CRN
		3615 MUELLER ROAD Sheboygan WI 53081					
	3	EQUIPMENT SHED 3615 MUELLER ROAD Sheboygan WI 53081	1980	1	945	\$47,646	\$13,116
	4	GARAGE 3615 MUELLER ROAD Sheboygan WI 53081	1974	1	1,200	\$63,532	\$38,290
	5	GARAGE 3615 MUELLER ROAD Sheboygan WI 53081	1974	1	712	\$36,530	\$10,098
	6	STORAGE BUILDING 3615 MUELLER ROAD Sheboygan WI 53081	1980	1	3,360	\$171,537	\$47,196
		MAYWOOD (25) Total				\$501,902	\$137,118
26		MEAD PUBLIC LIBRARY					
	1	SHEBOYGAN PUBLIC LIBRARY 710 Plaza 8 Sheboygan WI 53081	1975	3	49,031	\$11,967,951	\$9,529,228
		Property in the open					\$40,966
		MEAD PUBLIC LIBRARY (26) Total				\$11,967,951	\$9,570,194
27		BUS TERMINAL					
	1	BUS TERMINAL 608 South Commerce Street Sheboygan WI 53081	1975	1	40,734	\$6,106,351	\$847,042
		Property in the open					\$1,218,972
		BUS TERMINAL (27) Total				\$6,106,351	\$2,066,014
28		ENVIRONMENTAL CENTER					
	1	MAYWOOD 3615 MUELLER ROAD Sheboygan WI 53081	1974	1	3,772	\$333,540	\$68,359
	2	MAYWOOD WITH ADDITION 3615 Mueller Road Sheboygan WI 53081	2006	2	11,648	\$2,295,583	\$264,700
		Property in the open					\$3,662
		ENVIRONMENTAL CENTER (28) Total				\$2,629,123	\$336,721
29		NORTH SIDE PUMP STATION					
	1	NORTHSIDE PUMP STATION NORTH 3RD & BLACKSTOCK Sheboygan WI 53081	1970	1	150	\$20,841	\$152,848
		NORTH SIDE PUMP STATION (29) Total				\$20,841	\$152,848

STATEMENT OF VALUES

MUNICIPAL PROPERTY INSURANCE COMPANY

Coverage Amount - 214,026,961

Site	Bldg	Description	Year Built	Floors	Square Footage	Building CRN	Content CRN
30		SOUTH SIDE PUMP STATION					
	1	SOUTHSIDE PUMP STATION 1218 SOUTH 7TH STREET Sheboygan WI 53081	1950	1	7,500	\$473,172	\$563,351
		SOUTH SIDE PUMP STATION (30) Total				\$473,172	\$563,351
31		FIRE DEPARTMENT					
	1	FIRE DEPARTMENT #4 2622 N. 15th Street Sheboygan WI 53081	1988	2	8,726	\$1,753,143	\$476,461
		FIRE DEPARTMENT (31) Total				\$1,753,143	\$476,461
32		WASTE WATER TREATMENT PLANT					
	1	ADMINISTRATION BUILDING 3333 LAKESHORE DRIVE Sheboygan WI 53081	1980	1	19,575	\$2,135,945	\$409,528
	2	CHEMICAL STORAGE BUILDING 3333 LAKESHORE DRIVE Sheboygan WI 53081	1980	1	20,000	\$2,208,634	\$80,297
	3	PUMP STATION 3333 LAKESHORE DRIVE Sheboygan WI 53081	1980	1	10,800	\$1,215,559	\$1,860,023
	4	SOLIDS HANDLING BUILDING 3333 LAKESHORE DRIVE Sheboygan WI 53081	1980	1	3,096	\$374,123	\$17,756
	5	WASTEWATER TREATMENT PROCESS N3333 LAKESHORE DRIVE Sheboygan WI 53081	2006	0	0	\$75,206,567	\$0
		Property in the open					\$1,685,881
		WASTE WATER TREATMENT PLANT (32) Total				\$81,140,828	\$4,053,485
33		YOUTH BOATING FACILITY					
	1	YOUTH BOATING FACILITY 619 BROUGHTON DRIVE Sheboygan WI 53081	2004	1	1,780	\$287,598	\$6,947
		YOUTH BOATING FACILITY (33) Total				\$287,598	\$6,947
34		HARBOR CENTRE MARINA					
	1	ADMINISTRATION BUILDING 821 Broughton Drive Sheboygan WI 53081	2004	2	11,322	\$1,951,002	\$137,644
	2	FUEL ATTENDANT'S BUILDING	2004	1	780	\$123,355	\$55,617

STATEMENT OF VALUES

MUNICIPAL PROPERTY INSURANCE COMPANY

Coverage Amount - 214,026,961

Site	Bldg	Description	Year Built	Floors	Square Footage	Building CRN	Content CRN
		821 BROUGHTON DRIVE Sheboygan WI 53081					
		Property in the open					\$6,716
		HARBOR CENTRE MARINA (34)				\$2,074,357	\$199,977
		Total					
35		DELAND PARK COMMUNITY CENTER					
	1	DELAND PARK COMMUNITY CENTER 901 BROUGHTON DRIVE Sheboygan WI 53081	1994	1	2,481	\$531,305	\$24,507
		DELAND PARK COMMUNITY CENTER (35) Total				\$531,305	\$24,507
36		SENIOR CENTER					
	1	SENIOR CENTER 428 Wisconsin Ave. Sheboygan WI 53081	1969	1	14,346	\$2,387,882	\$211,760
		SENIOR CENTER (36) Total				\$2,387,882	\$211,760
37		LIFT STATION INDIANA AVE.					
	1	INDIANA AVE. LIFT STATION 2827 INDIANA AVENUE Sheboygan WI 53081	1997	1	648	\$752,322	\$648,941
		LIFT STATION INDIANA AVE. (37) Total				\$752,322	\$648,941
38		LIFT STATION 29TH & GEELE					
		Property in the open					\$281,111
		LIFT STATION 29TH & GEELE (38) Total				\$0	\$281,111
39		POTH FARM					
	1	POTH FARM 1920 STAHL ROAD Sheboygan WI 53081	1900	2	2,500	\$332,118	\$0
		POTH FARM (39) Total				\$332,118	\$0
40		FISH CLEANING STATION/RESTROOMS					
	1	FISH CLEANING STATION / RESTROOM SOUTH PIER DRIVE Sheboygan WI 53081	2005	1	1,262	\$390,468	\$5,942
		FISH CLEANING STATION/RESTROOMS (40) Total				\$390,468	\$5,942
41		SHERIDAN PARK					

STATEMENT OF VALUES

MUNICIPAL PROPERTY INSURANCE COMPANY

Coverage Amount - 214,026,961

Site	Bldg	Description	Year Built	Floors	Square Footage	Building CRN	Content CRN
		Property in the open					\$178,367
		SHERIDAN PARK (41) Total				\$0	\$178,367
42		VETERANS PARK					
	1	Park Open Pavilion 2220 Union Ave Sheboygan WI 53081	2013	1	864	\$51,944	\$10,928
	2	Rest Room facilities 2220 Union Ave Sheboygan WI 53081	2013	1	480	\$89,664	\$6,072
		VETERANS PARK (42) Total				\$141,608	\$17,000
43		OPTIMIST PARK					
	1	Park Open Pavilion 2004 Carmen Ave Sheboygan WI 53081	2013	1	864	\$51,944	\$10,928
	2	Restroom Facility 2004 Carmen Ave Sheboygan WI 53081	2013	1	420	\$80,388	\$6,072
		OPTIMIST PARK (43) Total				\$132,332	\$17,000
44		VOIGHT PARK					
		Property in the open					\$27,021
		VOIGHT PARK (44) Total				\$0	\$27,021
45		Sports Complex (Butzen Estate)					
	1	Farmstead Garage 3936 S Business Dr Sheboygan WI 53081	1890	1	548	\$13,082	\$0
	2	Garage [1B] 3936 S Business Dr Sheboygan WI 53081	1960	1	507	\$11,892	\$0
	3	House 3936 S Business Dr Sheboygan WI 53081	1960	1	1,194	\$106,439	\$5,935
	4	Original Farm Home 3936 S Business Dr Sheboygan WI 53081	1890	2	1,131	\$101,088	\$0
	5	Pole Barn 3936 S Business Dr Sheboygan WI 53081	1970	1	786	\$23,784	\$0
	6	Storage Shed 3936 S Business Dr Sheboygan WI 53081	1900	1	726	\$8,920	\$0

STATEMENT OF VALUES

MUNICIPAL PROPERTY INSURANCE COMPANY

Coverage Amount - 214,026,961

Site	Bldg	Description	Year Built	Floors	Square Footage	Building CRN	Content CRN
	7	SUMMER KITCHEN 3936 S Business Dr Sheboygan WI 53081	1920	1	250	\$5,946	\$0
		Sports Complex (Butzen Estate)				\$271,151	\$5,935
		(45) Total					
46		999 PITO THROUGHOUT / CE					
		Property in the open					\$1,284,802
		999 PITO THROUGHOUT / CE (46)				\$0	\$1,284,802
		Total					
47		PARK CE					
		Property in the open					\$117,718
		PARK CE (47) Total				\$0	\$117,718
48		Social Security Building					
	1	Social Security Building (vacant) 606 N 9th St Sheboygan WI 53081	0	0	0	\$296,400	\$0
		Social Security Building (48) Total				\$296,400	\$0
		Building Subtotal					\$177,776,207
		Contents Subtotal					\$26,986,274
		Property in the Open Subtotal					\$9,264,480
		Building, Contents and PITO Total					\$214,026,961

PROPERTY IN THE OPEN

MUNICIPAL PROPERTY INSURANCE COMPANY

Site	Description	New Cost of Replacement
1	CITY HALL	
	COMMUNICATIONS TOWER	\$12,913
	CITY HALL (1) TOTAL	\$12,913
4	FIRE ENGINE HOUSE 3	
	LADDER,HORIZONTAL	\$809
	FIRE ENGINE HOUSE 3 (4) TOTAL	\$809
9	ROOSEVELT PARK	
	PLAYSTRUCTURE,WOOD LRG	\$503,673
	TENNIS COURT,TWO	\$361,614
	ROOSEVELT PARK (9) TOTAL	\$865,287
11	DELAND PARK	
	BENCHES	\$12,431
	PLAYSTRUCTURE	\$28,337
	STAGING	\$47,094
	TENNIS COURT,FOUR	\$77,488
	BOUNCER,ANIMAL	\$1,612
	CONTROL GATE	\$40,425
	OUTDOOR LIGHTING	\$423,378
	PICNIC PAVILION	\$22,472
	PICNIC SHELTERS	\$25,525
	PICNIC SHELTERS	\$25,525
	PICNIC TABLES	\$22,617
	PLAYSTRUCTURE	\$61,244
	DELAND PARK (11) TOTAL	\$788,147
13	VOLLRATH PARK	
	GOAL,BASKETBALL DOUBLE	\$16,141
	Nucleus Play Structure	\$34,742
	OUTDOOR LIGHTING	\$1,132,623
	PICNIC PAVILION	\$22,472
	VOLLRATH PARK (13) TOTAL	\$1,205,979
15	EVERGREEN PARK	
	PICNIC PAVILION	\$22,472
	PLAYGROUND EQUIPMENT TRI ACTIVE	\$9,385
	EVERGREEN PARK (15) TOTAL	\$31,857
16	JAYCEE PARK	
	RETAINING WALL	\$770,537
	RUNNING TRACKS - VITA COURSE	\$36,912
	JAYCEE PARK (16) TOTAL	\$807,449
17	KIWANIS PARK	

PROPERTY IN THE OPEN

MUNICIPAL PROPERTY INSURANCE COMPANY

Site	Description	New Cost of Replacement
	PICNIC PAVILION	\$22,472
	KIWANIS PARK (17) TOTAL	\$22,472
20	CLEVELAND PARK	
	JUNGLE GYM(BAR CLIMBER)	\$7,747
	CLEVELAND PARK (20) TOTAL	\$7,747
21	WILDWOOD BASEBALL COMPLEX	
	BACKSTOP BASEBALL	\$72,326
	BENCH,PARK WOOD	\$113,002
	BLEACHER ALUMINUM	\$104,933
	BLEACHER ALUMINUM	\$8,395
	KOMPAN PLAYGROUND EQUIPMENT	\$9,667
	SCOREBOARD,LRG	\$64,573
	WILDWOOD BASEBALL COMPLEX (21) TOTAL	\$372,895
23	ROTARY RIVERVIEW PARK	
	PICNIC PAVILION	\$89,912
	PICNIC TABLE	\$150,671
	PLAYSTRUCTURE, LG WOOD	\$38,743
	PLAYVENTURE	\$15,772
	SEESAW	\$8,611
	ROTARY RIVERVIEW PARK (23) TOTAL	\$303,709
26	MEAD PUBLIC LIBRARY	
	LIBRARY SCULPTURES - FOUR	\$40,966
	MEAD PUBLIC LIBRARY (26) TOTAL	\$40,966
27	BUS TERMINAL	
	BUS SHELTER	\$209,702
	BUS SHELTER	\$862,365
	PARKING METER	\$146,904
	BUS TERMINAL (27) TOTAL	\$1,218,972
28	ENVIRONMENTAL CENTER	
	FIRE TOWER	\$3,662
	ENVIRONMENTAL CENTER (28) TOTAL	\$3,662
32	WASTE WATER TREATMENT PLANT	
	FENCE,CHAINLINK OVER 6FT.	\$281,377
	VERDESIS MICRO-TURBINS (TWO - 2)	\$1,404,503
	WASTE WATER TREATMENT PLANT (32) TOTAL	\$1,685,881
34	HARBOR CENTRE MARINA	
	FLOATING DOCK	\$6,716
	HARBOR CENTRE MARINA (34) TOTAL	\$6,716

**PROPERTY IN THE OPEN
MUNICIPAL PROPERTY INSURANCE COMPANY**

Site	Description	New Cost of Replacement
38	LIFT STATION 29TH & GEELE	
	6TH ST & PERSHING PKG LIFT STN	\$115,755
	INDIAN MEADOWS PKG LIFT STN	\$118,829
	LIFT STATION	\$46,526
	LIFT STATION 29TH & GEELE (38) TOTAL	\$281,111
41	SHERIDAN PARK	
	Picnic Pavilion - steel	\$94,314
	SWING,ANIMAL	\$26,152
	SWING,BELT	\$39,605
	WHIRL	\$18,296
	SHERIDAN PARK (41) TOTAL	\$178,367
44	VOIGHT PARK	
	Nucleus Play Structure	\$27,021
	VOIGHT PARK (44) TOTAL	\$27,021
46	999 PITO THROUGHOUT / CE	
	STREET LIGHTING	\$1,284,802
	999 PITO THROUGHOUT / CE (46) TOTAL	\$1,284,802
47	PARK CE	
	DINO CLIMBER	\$7,219
	PLAYGROUND EQUIPMENT	\$67,339
	PLAYGROUND EQUIPMENT	\$19,453
	PLAYSTRUCTURE, WD SMALL	\$9,591
	TRACK RIDE	\$14,116
	PARK CE (47) TOTAL	\$117,718
PROPERTY IN THE OPEN TOTAL		\$9,264,480

CONTRACTOR'S EQUIPMENT MUNICIPAL PROPERTY INSURANCE COMPANY

Description	RCN Subject
2009 JOHN DEERE 624K LOADER	\$169,003
2009 JOHN DEERE 624K LOADER	\$169,003
2007 ASPHALT ZIPPER X00012-0 AZ500 48 HD ASPHALT ZIPPER	\$116,495
2007 FALCON Hot Patcher PAVING EQUIPMENT(TAR KETTLE)	\$16,312
2007 SMITHCO SUPER RAKE MOWER	\$14,469
2007 ARROW 1350 ROAD EQUIPMENT(ROLLER)	\$101,677
2012 YES 2CX-12 BACK HOE	\$81,629
2012 BAY VERTE REDML5435E TRAILER	\$31,574
2011 BOBCAT 5600 Turbo Toolcat F-Series EARTH MOVING EQUIPMENT(RUBBER TIRED	\$54,173
2011 DOOSAN G30P-5 6000# Fortklift FORK LIFT	\$29,991
2010 EXCEL HUSTLER MODEL 796623 MOWER	\$10,567
2004 JOHN DEERE 310SG M150 LOADER	\$70,569
2004 SEWER EQUIPMENT M239 VACUUM TRAILER	\$109,717
2002 JACOBSEN 628D TURFCAT M355 MOWER	\$23,921
2001 COMP AIR FIRE COMPRESSOR	\$19,399
2001 FELLING 420 M420 TRAILER	\$7,948
2001 BOMAG 120AD3 M152 ROLLER	\$42,116
1999 NEW HOLLAND TC33D TRACTOR	\$16,835
2001 RAYCO RG50 M282 GRINDER	\$38,880
2001 TARGET CH0267 M234 CONCRETE SAW	\$23,847
2001 HYUNAI F42033 M148 EXCAVATOR	\$187,988
2001 EAST HT300 M125A TRIAXLE TRAILER	\$23,357
1988 GIANT VAC 6800 281 LEAF MACHINE-TR20	\$29,649
1981 FMC D050E 0284 SPRAYER	\$48,604
1981 INGERSOLL-RAND P175WD 0253 AIR COMPRESSOR	\$22,724
1987 DYNAPAC LR100 0153 ROLLER/COMPACTOR	\$33,089
1988 POWER BOSS SW88HD TRANSIT SWEEPER	\$33,860
1986 CUSHMAN 22 TRACTOR-FRONTLINE 3WHEEL	\$10,858
1975 KLAUER MP-30 SNOGO BLOWER 180A	\$73,133
1990 EAGER BEEVER 290 M287 CHIPPER	\$26,593
1990 EAGER BEEVER 290 M286 CHIPPER	\$26,593
1991 LONGYEAR 6500 M233 CONCRETE SAW	\$27,951
1988 SCHMIDT HF-2 M181A SNOW CUTTER	\$130,862
2004 KOHLER 30RZG FIRE GENERATOR	\$36,001
1990 JOHN DEERE M163 TRACTOR	\$26,242
1978 KOHLER 100RHZ81 GENERATOR	\$45,731
1976 KOHLER 7.5RMK62 EMERGENCY GENERATOR	\$13,505
2006 VOLVO L110E WHEEL LOADER	\$209,577
2006 BOBCAT 5600C TOOLCAT UTILITY WORK MACHINE	\$63,184
2006 LEEBOY 8515 PAVER	\$128,679
2006 BANDIT 250C53 CHIPPER	\$30,713
2006 BANDIT 250C53 CHIPPER	\$30,713
2006 TENNANT 8210 SWEEPER/SCRUBBER	\$49,102
2006 BOBCAT DHAM DROP HAMMER	\$7,125
2006 DEWEZE 05A59 SLOPE MOWER	\$37,843
2006 HUSTLER SUPER Z 23KAW MOWER	\$7,378
2006 HUSTLER SUPER Z 23KAW MOWER	\$7,378
2006 JOHN DEERE 6420 UTILITY TRACTOR	\$88,073
2006 BOBCAT s185 SKIDSTEER LOADER	\$34,431
2006 COMMERCIAL SSM38-720 SLOPE MOWER	\$55,735
2006 PACE AMERICAN CS716TA3 TRAILER	\$9,437

CONTRACTOR'S EQUIPMENT

MUNICIPAL PROPERTY INSURANCE COMPANY

Description	RCN Subject
2005 SIMPLICITY STALLION C MOWER AND MULCH KIT, 25HP	\$8,242
1991 KNOWLES 24FT. F018 TRAILER	\$29,684
2005 HURST JL F RAM UNIT	\$14,405
2006 KOHLER 30RZG F GENERATOR	\$25,682
1998 Zodiac MK2 Boat	\$12,947
1994 KUBOTA CEM1 TRACTOR	\$12,223
1995 DEWEZE ATM70C M343 MOWER	\$25,143
1995 VERMEER 1102 M285 STUMP GRINDER	\$48,592
1995 CRAFTCO EX100D M230 MELTER	\$31,674
1995 CRAFTCO 200 M227 ROUTER	\$10,802
1995 JOHN DEERE 2105 M156 BACKHOE	\$63,561
1993 FORD M169 TRACTOR MOTT MOWER	\$50,799
1992 JOHN DEERE 544E M183 WHEEL LOADER	\$164,909
1992 EXCEL HUSTLER 440ST M342 MOWER/SNOW GROOMER	\$63,861
1994 GPX 20E 0130 FORKLIFT	\$23,696
1994 SMITHCO 0176 SUPER RAKE	\$16,157
1994 CASE 621B 0186 LOADER	\$122,187
1994 CASE 821B 0187 LOADER	\$192,358
1994 GIANT VAC 6800-TR 0279 LEAF LOADER	\$25,468
1996 HOWARD-PRICE 727 M345 MOWER	\$21,947
1996 HOLDER MTC9700 0166 TRACTOR	\$68,007
1996 SULLIVAN 1850PQJD 0254 AIR COMPRESSOR	\$14,814
1990 MFD M159 TRACTOR, CAB, LOADER	\$44,248
1997 NEW HOLLAND 1620A4 M162 TRACTOR	\$14,266
1997 NEW HOLLAND 3430 M161 TRACTOR	\$17,556
1998 M121 VERSALIFT	\$82,491
1997 LEACH M122 VAC-ALL	\$237,496
1995 SIMON M123 TELELECT	\$102,767
1997 DAEWOO M131 FORK TRUCK	\$28,901
1997 JOHN DEERE M154 BACKHOE	\$96,193
2003 JOHN DEERE X595 M170 TRACTOR	\$12,989
2003 SKID 00-SKB700 VACUUM	\$18,467
2003 SHANDIC SKI-DOO SNOWMOBILE	\$13,375
2003 HONDO BLITZ SCREED	\$11,353
2003 BOBCAT S185 M137 SKIDSTEER	\$44,710
2005 BOBCAT 5600C M139 TOOLCAT	\$66,151
2005 BOBCAT 5600C M138 TOOLCAT	\$66,151
2005 BEACH TECH 3000 M BEACH TECH	\$115,798
2005 KAWASAKI M167 MULE	\$11,763
2005 KAWASAKI M339 MOWER, HUSTLER MINI SUPER Z	\$8,662
2005 CIMLINE 110DC M CRACK FILLING MELTER/APPLICATOR	\$43,207
2012 ODB ODLCT650 Leaf Collector	\$22,440
2012 ODB ODLCT650 Leaf Collector	\$22,440
2012 ODB ODLCT650 Leaf Collector	\$22,440
2012 ODB ODLCT650 Leaf Collector	\$22,440
2011 Bobcat 5600 Bobcat Toolcat F-Series	\$44,132
2011 Doosan G30P-5 Forklift Truck	\$30,385
2012 Radar THL/SRO Trailer W/Traffic Collector	\$9,315
2012 Hustler Excel 929927 Mower	\$13,360
2012 Hustler Excel 929927 Mower	\$13,360
2011 Ferris IS3100Z Mower	\$14,147

CONTRACTOR'S EQUIPMENT MUNICIPAL PROPERTY INSURANCE COMPANY

Description	RCN Subject
2011 Ferris IS3100Z Mower	\$14,147
2011 Bobcat 5600 Turbo Bobcat	\$53,134
2011 Bay Verte REDML5435E Trailer	\$31,967
2011 Doosan G309-5 Forklift Truck	\$30,385
2011 HYD ATSRX6 Breaker	\$8,097
2011 JCB 2CX-12 Backhoe	\$80,266
2010 DEWEZE ATM72LC MOWER	\$36,728
2010 FRUEHAUF Rock Tub 7 cu yd TRAILER	\$16,203
2010 VOLVO EW180C EXCAVATOR	\$167,023
2010 KUBOTA V3300T MOWER	\$74,289
2010 SPAULDING RMV-2 PAVING EQUIPMENT(TAR KETTLE)	\$30,122
2010 SPAULDING RMV-2 PAVING EQUIPMENT(TAR KETTLE)	\$30,122
2009 HUSTLER Z4 MOWER	\$8,092
2008 FERRIS M330 MOWER	\$10,051
2008 FERRIS M331 MOWER	\$10,051
2009 FERRIS M318 MOWER	\$8,975
2010 HUSTLER 24 M322 MOWER	\$7,742
2008 AERWAY TURF M347 AERATOR	\$10,593
2009 ARTICULATED M520 TRACTOR	\$139,619
2009 ARTICULATED M521 TRACTOR	\$139,619
2007 LINELAZER IV5900 PAINTING MACHINE	\$7,206
2015 Case 821F Wheel Loader	\$223,660
2017 Bomag CR352 Bomag CR352 Paver	\$361,053
2005 CUB CADET 4X2TRAIL UTILITY VEHICLE 4 X 2	\$10,167
1998 TORO 3200 UTILITY TRUCK WORKMAN	\$23,499
2009 KAWASAKI 4010 Mule TRACTOR	\$11,267
2009 SCHWARZE A7000 ROAD EQUIPMENT(SWEEPER)	\$169,003
2008 TURFCAT 628D MOWER	\$45,067
2008 WAUSAU MP 3-D SNOWBLOWER	\$123,936
2010 JOHN DEERE 2020A PRO GATOR TRACTOR	\$12,853
2010 SCHWARZE A7000 Sweeper STREET SWEEPER	\$197,768
2010 SCHWARZE A7000 Sweeper STREET SWEEPER	\$197,768
2005 CONFLICT PCMT2600 M248 MONITOR TESTER	\$13,478

CONTRACTOR'S EQUIPMENT TOTAL	\$6,515,257
-------------------------------------	--------------------

MUNICIPAL PROPERTY INSURANCE COMPANY

TABLE OF CONTENTS

SECTION I - PERILS "COVERED"	2
SECTION II – DEDUCTIBLE	2
SECTION III - AMOUNT OF COVERAGE	2
SECTION IV - "COVERED" PROPERTY; LIMIT OF COVERAGE	2
SECTION V - PROPERTY NOT "COVERED"	10
SECTION VI - LOSSES EXCLUDED	10
SECTION VII - BASIS OF RECOVERY	12
SECTION VIII - CONDITIONS	13
SECTION IX - DEFINITIONS	16
SECTION X - DEFINITION OF "CONTRACTORS EQUIPMENT"	20

MUNICIPAL PROPERTY INSURANCE COMPANY

9701 Brader Way, Suite 301, Middleton, WI 53562

Policy Provisions

Read the entire policy carefully to determine rights, duties, and what is and what is not "covered." Several provisions in this policy restrict coverage.

Throughout this policy, the words "you" and "your" refer to the Named Insured shown on the Declarations page. The words "we", "us" and "our" refer to Municipal Property Insurance Company. Other words and phrases that appear in quotation marks have special meaning. Refer to Section IX, Definitions, and Section IV. Definition of "Contractors Equipment".

In consideration of the provisions of this policy, the payment of premium, receipt of a statement of values, "Property in the Open" schedule and/or contractors equipment detail, we insure those named on the Declaration page for the coverages defined in this policy, during the policy term stated on the Declarations Page.

SECTION I – PERILS "COVERED" Coverage: This policy insures against sudden and accidental direct physical loss or damage except as limited or excluded in the following sections.

SECTION II – DEDUCTIBLE

The amount shown as deductible on the Declarations page shall be deducted from the claim for each "occurrence".

If more than one coverage under this policy applies to the same "occurrence", then the deductible will be calculated as follows: we will determine which coverage accounts for the largest proportion of the loss, and only the deductible associated with the largest portion of the loss will apply, unless otherwise stated.

SECTION III – AMOUNT OF COVERAGE

With regard to "buildings", personal property regardless of its location, and "Property in the Open":

The amount of coverage shall be limited as stated in Sections IV, V and VII.

Unless limited by other provisions of this policy or by endorsement, "buildings", personal property, and "Property in the Open", are subject to an "occurrence" limit of 125% of the Total Insured Value shown on the Statement of Values.

SECTION IV – "COVERED" PROPERTY; LIMIT OF COVERAGE

Subject to the terms, conditions, limitations and exclusions in the policy, this policy covers:

- A. "Buildings" and structures listed on the Statement of Values.
- B. Non-Owned Property. "Buildings" and structures listed on the Statement of Values for which you may be contractually liable in the event of damage or destruction and which are in your care, custody or control and being used for a legitimate governmental purpose.
- C. Personal property you own or are legally responsible for insuring.
- D. "Property in the Open". The amount we will pay for "Property in the Open" is limited to \$10,000 per "occurrence". However, this \$10,000 limitation per "occurrence" does not apply to items listed separately on the Statement of Values "Property in the Open" detail list.

- E. Leased property improvements and betterments at locations listed on the Statement of Values. In the event improvements or betterments made by you are damaged or destroyed during the term of this policy by an insured peril, our liability will be determined as follows:
1. If you elect to repair or replace a damaged improvement or betterment, actual repair or replacement must be made as soon as reasonably possible after the loss or damage occurs, but not to exceed two (2) years unless the time is extended in writing by us.
 2. If the improvements or betterments are not repaired or replaced, we will pay a fraction of the original cost of the improvement. The fraction will be proportional to the remaining term of the lease as of the date of loss.
- F. The cost of removing debris when "covered" property is destroyed or damaged by an insured peril. However, unless otherwise provided for in this policy, debris removal does not apply to costs:
1. To extract "pollutants" or "contaminants" from land or water; or
 2. To remove, restore or replace land or water containing or affected by "pollutants" or "contaminants"; or
 3. For asbestos cleanup, removal or abatement.
- G. The cost to repair or replace foundations of "buildings", structures, machinery or boilers if their foundations are at or below:
1. The lowest basement floor; or
 2. The surface of the ground if there is no basement.
- The most we will pay for any "occurrence" under this section is \$100,000.
- H. The cost of excavation, grading or filling related to an "occurrence", the most "we" will pay under this coverage is \$50,000
- I. Lawns, trees, shrubs, and plants if within 100 feet of an insured "building". The amount we will pay is limited to \$500 for any one tree, shrub, or plant and \$1,000 for lawn damage up to a maximum of \$5,000 per "occurrence"
- J. Contractors Equipment", as defined in Section X., that you own or are legally responsible for insuring up to a limit of \$25,000 for each item including its attachment(s). Equipment not listed in Section X. is considered personal property and is "covered" the same way as your other personal property. See Section IV.C.

Coverage, in excess of the \$25,000 per item, is provided only if the equipment is scheduled and a premium for the coverage is shown on the Declarations page, unless the equipment is newly acquired during the current policy period, provided your interest is not covered under any other policy of insurance.

- K. "Valuable Records" that are your property or property of others in your care, custody, or control.

We will also pay for:

1. Expenses necessary to research and recreate lost "valuable records"; and
2. Expenses necessary for transcribing or copying lost "valuable records" from available secondary sources.

We will not pay for losses caused by errors, omissions, or negligence in processing or copying.

- L. **Employees' Personal Property.** We will cover personal property owned by your employees while on your premises if that employee's property is not covered by other insurance. The maximum coverage for property owned by any one employee is \$500. The coverage limit for each "occurrence" is \$10,000.
- M. **Personal property owned by someone other than you or your employees,** if the personal property is not covered by other insurance, while it is in your care, custody, or control and while it is on the premises described in the Statement of Values. The coverage limit per "occurrence" for all such property is \$10,000.
- N. **"Extra Expense".** Provided a loss or damage to "covered" property is caused by an insured peril we will pay up to a maximum of \$10,000,000 (unless a higher limit has been established by Endorsement) under this "extra expense" coverage subject to the following:

We will pay "Extra Expense" to allow you to continue "operations" at:

- 1. Your insured premises; or
- 2. Replacement premises; or
- 3. Temporary premises you use while your insured premises are being restored.

Costs to relocate, or to equip and operate the premises in N.2 or N.3, are covered.

Adjustment of any loss under this coverage will reflect the salvage value of property that you obtained for use while your property was being restored and that you retain after the resumption of normal "operations".

- O. **"Buildings"** or structures acquired by you during the policy period at any location, provided your interest is not covered under any other policy of insurance.
- P. **Remodeling and repairs to existing buildings** listed on the Statement of Values unless the work involves an increase in square footage or a change in the footprint of the building or foundation.
- Q. **Underground fiber optic cable.** We will pay for the repair or replacement of underground fiber optic cable within 1000 feet of your "building" when loss of or damage to the cable is caused by a "covered" peril.
- R. **Refrigerated Property.** We will pay for loss or damage you sustain from spoilage of refrigerated or perishable property you own or are legally responsible to insure, if the spoilage is due to:
 - 1. Contamination by a refrigerant; or
 - 2. Temperature change due to:
 - a. Mechanical breakdown or failure of refrigeration systems;
 - b. Burning out of electric motors;
 - c. Blowing of fuses or circuit breakers;
 - d. The breakdown or malfunction of the equipment or apparatus connecting or controlling refrigeration systems, electrical motors, or electrical power; or
 - e. Complete or partial lack of power to operate the refrigeration systems.
- S. **Ordinance or Law Coverage.**

Provided a loss or damage to "covered" property is caused by an insured peril we will pay up to a maximum of \$5,000,000 (unless a higher limit has been established by endorsement) for the increased cost to repair, rebuild

or reconstruct "covered" property caused by enforcement of or compliance with a building, zoning or land use ordinance or law subject to the following:

1. We will also pay for loss or damage to the undamaged portion of a "covered" "building" or structure caused by enforcement of or compliance with any ordinance or law that:
 - a. Requires the demolition of parts of the same "building" or structure not damaged by an insured peril;
 - b. Regulates the construction or repair of "buildings" or structures, or establishes zoning or land use requirements at the described premises; and
 - c. Is in force at the time of loss or damage.
2. We will not pay under this coverage:
 - a. Until the property is actually repaired or replaced; and
 - b. Unless the repairs or replacement are made as soon as reasonably possible after the loss or damage, not to exceed two (2) years unless the time is extended in writing by us.
3. If the property is repaired or rebuilt, it must be intended for similar occupancy as the current property, unless otherwise required by zoning or land use ordinance or law.
4. The most we will pay under this coverage is the increased cost of construction at the same premises, unless an ordinance or law requires relocation to another premises, in which case the most we will pay is the increased cost of construction at the new premises.
5. If the property is repaired or replaced on the same or another premises, we will not pay more for loss or damage to "covered" property, including loss caused by enforcement of or compliance with an ordinance or law, than the amount you actually spend to repair, rebuild or reconstruct the "building" or structure to the minimum standards required by the ordinance or law. In no event will we pay more than the following:
 - a. For a "historical building", the amount it would cost to repair, rebuild or reconstruct the "building" or structure on the same premises and to the same height, square footage and style with a less costly "building" or structure that is:
 - 1) Functionally equivalent to the damaged "building" or structure; or
 - 2) The cost to repair or replace the damaged portion of the "covered" property with less costly material, if available, in the architectural style that existed before the loss or damage occurred.
 - b. For all other "covered" "buildings" or structures, the amount it would cost to repair, rebuild or reconstruct the "building" or structure on the same premises and to the same height, square footage, style and comparable quality of the "covered" property at the time of the loss or damage.
6. If the property is not repaired or replaced, we will not pay more for loss or damage to "covered" property, including loss caused by enforcement of or compliance with an ordinance or law, than the "actual cash value" of the "covered" property at the time of the loss or damage.
7. We will not pay for the cost of compliance with any ordinance or law that requires:
 - a. Repairing, remediating, or tearing down property due to "contaminants" or "pollutants" or resulting from the presence or spread of "fungus", wet or dry rot, viruses, bacteria, or other microorganisms; or,
 - b. Testing for, monitoring, or cleaning up "pollutants", "contaminants", wet or dry rot, "fungus", viruses, bacteria, or other microorganisms.

T. Limited Coverage for Unscheduled "Buildings" and "Property in the Open".

For unscheduled "buildings" and "Property in the Open" not on the Statement of Values, coverage will be provided up to \$1,000,000 for a covered loss.

It is a condition of this coverage that the "buildings" and "Property in the Open" be scheduled when discovered. In addition, you must pay any unpaid premium on the unscheduled "building" or "Property in the Open" back to policy inception.

This coverage does not apply when:

1. The insured intentionally left the "buildings and "Property in the Open" unscheduled; or
2. The insured could have discovered with reasonable diligence that the "buildings and "Property in the Open" had unintentionally been left unscheduled.

This provision does not apply to "buildings" or structures acquired by you during the policy period as coverage for these items is provided in Section IV.O.in this policy.

U. Electronic data processing equipment, "electronic data" and "computer programs" consisting of the following:

1. Electronic data processing equipment owned by or leased to you, including its component parts and similar property of others for which you are legally liable;
2. Your "electronic data", "computer programs" and similar property of others for which you are legally liable.
3. Accounts, bills, evidences of debt, valuable papers, records, abstracts, deeds, manuscripts or other documents that were converted to "electronic data".
4. We will also pay for:
 - a. Expenses necessary to research and recreate lost "electronic data";
 - b. Expense for copying lost "electronic data" from available secondary sources.
5. We will not cover:
 - a. "Electronic data" or "computer programs" which cannot be replaced with others of the same kind or quality;
 - b. Losses caused by errors, omissions, or negligence in processing or copying; or,
 - c. Accounts that are your records of accounts receivables.

V. Fire Department Charges.

We will reimburse you up to \$25,000 at each premises for charges of each fire department involved in containing a fire or other "covered" loss to which this insurance applies. No deductible applies to this reimbursement.

W. Asbestos Cleanup, Abatement and Removal.

We will pay up to \$5,000,000 for your expense to clean up, abate, or remove from "covered" property asbestos particles that are discharged, dispersed, or released, subject to the following conditions:

1. The discharge, dispersal, or release must occur as a result of a covered peril.

2. Covered damages before the cost of the asbestos cleanup, removal, or abatement must exceed the policy deductible.
3. The discharge, dispersal, or release must occur accidentally and begin and end within 72 hours.
4. The discharge, dispersal, or release must not be the result of planned building renovation, remodeling or demolition activities.

X. Police Dogs and Horses.

Police dogs and horses are considered to be destroyed if because of injury the dog or horse is not able to perform the dog's or horse's normal functions and there is no reasonable prospect that the dog or horse will be able to do so.

1. For police dogs and horses that are destroyed, we will pay for the cost to replace the dog or horse and the cost of any necessary training.
2. We will pay the cost of necessary treatment and care to enable the dog or horse to resume performing the dog's or horse's normal functions. But we will not pay the cost of treatment and care to treat and prevent disease. It is not the intent to provide mortality or sickness coverage for causes outside the scope of duties of the police dog or horse.

The maximum amount we will pay per police dog or horse is the lesser of \$25,000 or the total of the expenses related to the replacement of the dog or horse plus expenses for the care or treatment of the police dog or horse. A deductible of \$1,000 will apply to this coverage on a per "occurrence" basis.

- Y. We will pay the reasonable and necessary expenses we require you to incur for the documentation of an "occurrence". The most we will pay for these expenses is \$50,000.

This coverage does not apply to any expenses incurred by "you" for any insurance adjusters, consultants, attorneys retained by you or any work performed by their subsidiary or affiliate.

- Z. We will pay for reasonable and necessary architectural design and engineering fees associated with an "occurrence". The most we will pay for this coverage is \$100,000.

AA. Limited Coverage For "Fungus", Wet Rot, Dry Rot, Virus, Bacterium And Other Microorganism.

1. The coverage described in Paragraph 2. below only applies when: a) the "fungus", wet or dry rot, virus, bacterium or other microorganism is the result of one or more of the "specified causes of loss", other than fire or lightning; b) the "specified causes of loss" occurs during the policy period; and c) you took all reasonable measures to protect the property from additional damage during and after the "occurrence".
2. We will pay for direct physical loss or damage caused by "fungus", wet or dry rot, virus, bacterium or other microorganism subject to the coverage limits specified in Paragraph 3 of this Limited Coverage. For purposes of this paragraph, the term "loss or damage" includes costs necessarily incurred to:
 - a. Eradicate the "fungus", wet or dry rot, virus, bacterium or other microorganism;
 - b. Access the part of the "building" or other property where the "fungus", wet or dry rot, virus, bacterium or other microorganism is located; and
 - c. Test to ensure that the "fungus", wet or dry rot, virus, bacterium or other microorganism has been successfully eliminated.
3. The coverage described under Paragraph 2. of this Limited Coverage is limited to \$25,000 for each "covered" loss and \$50,000 during any policy period. Regardless of the number of claims, this limit is the most we will

pay for the total of all loss or damage arising out of all occurrences of "specified causes of loss" (other than fire or lightning) which take place in a 12-month policy period. With respect to a particular "specified causes of loss" which results in "fungus", wet or dry rot, virus, bacterium or other microorganism, we will not pay more than a total of \$25,000 even if the fungus", wet or dry rot, virus, bacterium or other microorganism continues to be present or active, or recurs, in a later policy period.

4. The coverage provided under this Limited Coverage does not increase the applicable Limit of Insurance on any Covered Property. If a particular "specified causes of loss" results in loss or damage by "fungus", wet or dry rot, virus, bacterium or other microorganism and other loss or damage, we will not pay more for the total of all insurance on the affected Covered Property.

If there is "covered" loss or damage to Covered Property, not caused by "fungus", wet or dry rot, virus, bacterium or other microorganism loss payment will not be limited by the terms of this Limited Coverage, except to the extent that "fungus", wet rot or dry rot, virus, bacterium or other microorganism causes an increase in the loss. Any such increase in the loss will be subject to the terms of this Limited Coverage.

5. The following additional condition applies to losses "covered" under **Limited Coverage For "Fungus", Wet Rot, Dry Rot, Virus, Bacterium And Other Microorganism** when the policy includes the Business Income Endorsement: The "specified causes of loss" definition will apply to any loss arising from "fungus", wet or dry rot, virus, bacterium or other microorganism that is "covered" under Paragraph B. **Limited Coverage For "Fungus", Wet Rot, Dry Rot, Virus, Bacterium And Other Microorganism** and under the Business Income Endorsement.

BB. "Fine Arts". We will only provide coverage for "Fine Arts" subject to the following:

1. We will not pay more than \$50,000 for any one "Fine Arts" unless you insure those items for specific amounts by purchasing an Agreed Value Fine Arts endorsement.
2. The most we will pay for each item covered under this additional coverage shall not exceed the lesser of the following amounts:
 - a. \$50,000;
 - b. The cost of replacing the damaged property at the time of loss with property of like kind and quality to be used for the same purpose on the same site; or
 - c. The amount actually spent repairing your damaged property as soon as reasonably possible after the loss or damage, but within a time not to exceed two (2) years from the date of the loss or damage, unless the time is extended in writing by us.
3. **SECTION VII-Basis of Recovery** does not apply to this additional coverage.

CC. "Flood". We will provide coverage for loss due to "flood", subject to the following limitations:

- a This Additional Coverage does not apply to loss at any property located in a designated flood plain, special flood hazard area (SFHA) or 100 year flood plain with a prefix of "A" or "V" – as specified and defined by the National Flood Insurance Program (NFIP).

The most we will pay under this Coverage – "Flood" is \$5,000,000 per "occurrence".

DD. "Pollutants" or "Contaminants". We will pay no more than \$2,000,000 for reasonable and necessary expenses incurred for removal, disposal or clean-up of actual "pollutants" or "contaminants" from land or water at an insured location and due to "specified causes of loss". The discharge, dispersal, seepage, migration, release or escape of "pollutants" or "contaminants" must be caused by a loss not otherwise excluded.

However, the most we will pay in each annual policy period under this Additional Coverage is \$1,000,000 for all "specified causes of loss" losses.

This Additional Coverage does not apply to costs to test for, monitor or assess the existence, concentration or effects of "pollutants" or "contaminants". But we will pay for testing which is performed in the course of extracting the "pollutants" or "contaminants" from the land or water.

This coverage does not apply unless such expenses are reported to us within 180 days after the date of the "specified causes of loss" loss.

EE. Emergency Response Equipment

Emergency response equipment contained within or on an emergency response vehicle that is not affixed or attached is covered as personal property subject to a \$1,000 deductible per occurrence regardless of any other applicable deductible.

FF. "Buildings" and structures, including property contained within a "building" or structure, "vacant" for more than sixty (60) consecutive days before the loss or damage occurs. However, this paragraph only applies to the perils of: vandalism; sprinkler leakage or "water damage", unless you have used reasonable means to protect the sprinkler or plumbing system against freezing; building glass breakage; theft; or attempted theft. For all other perils "covered", loss adjustment shall be on an "actual cash value" basis for the "vacant" building, personal property and "Property in the Open" within 1,000 feet of the "vacant" building.

GG. We will pay not more than \$5,000,000 per occurrence of earth movement including, but not limited to, earthquake including tremors and aftershocks, landslide, mudslide, earth sinking, earth rising or shifting. We will also provide coverage for fire or explosion not excluded in this policy when resulting from a covered earth movement event.

SECTION V – PROPERTY NOT “COVERED”

The following are not “covered” property unless specifically added or endorsed to this policy:

- A. Land (including land on which the property is located), water, crops, and standing or cut timber, wherever located.
- B. Cost of excavation, grading or filling not related to an “occurrence”.
- C. Underground and buried cables, pipes, flues or drains, including those that are part of your storm, water or sewer systems, located more than 1,000 feet, on the horizontal, from a “covered” “building” or structure, except underground and buried pipes, flues or drains that are:
 - 1. Part of the water treatment plant, wastewater treatment plant, lift station or gas reduction station premises; or
 - 2. Part of a geothermal heating and cooling system.
- D. Those portions of sidewalks, bridges (including roadway bridges and railroad bridges), roadways, culverts, paved surfaces, and associated guard rails located more than 100 feet from a “covered” “building” or structure, except for bridges that are:
 - 1. Bridges used exclusively for pedestrian traffic.
- E. Dams, pavements, swimming pools and related equipment, retaining walls, bulkheads, piers, bridges, wharves and docks for damage caused by any of the following: freezing; thawing; impact of watercraft; the pressure or weight of ice or water, whether driven by wind or not; and, erosion or deterioration, whether gradual or sudden.
- F. Railroads, meaning trackage, beds, ties and railroad bridges; however, amusement park rail systems are “covered”, and railroads, meaning trackage, beds, ties and railroad bridges, are “covered” if within 100 feet of a “covered” “building” or structure.
- G. Aircraft, except for drones, and vehicles licensed for road use.
- H. Animals and livestock, except for police dogs and horses.
- I. “Money” and “securities”, including postage stamps and food stamps, deeds, evidence of debt, or accounts receivable.

SECTION VI – LOSSES EXCLUDED

- A. We will not pay for loss or damage caused directly or indirectly by, based upon, or arising out of any of the following:
 - 1. Wear and tear; extremes of temperatures unless you exercised due diligence with respect to maintaining the proper temperature for the property involved; dampness or dryness of atmosphere; deterioration; rust or corrosion; disease; inherent vice; inherent or latent defect; contamination; smog; smoke, vapor or gases from agricultural or industrial operations; error, omission, or deficiency in design, specifications, workmanship or materials; settling, cracking, shrinkage, bulging or expansion of pavements, sidewalks, foundations, walls, floors, roofs, or ceilings; insects, or birds; unless loss by a peril not excluded in this policy results, and then we will be liable for only such resulting loss.
 - 2. Unexplained or mysterious disappearance of any property or shortage disclosed upon taking inventory.
 - 3. Dishonest or criminal act committed by you or any “employee(s)” acting alone or in collusion with others whether or not occurring during the hours of employment. However, if a criminal act results in a “specified causes of loss”, we will pay for the loss or damage caused by that “specified causes of loss”.
 - 4. Discharge, dispersal, release or escape of “pollutants” or “contaminants”, subject to the following:

a. This exclusion does not apply:

1) If the discharge, dispersal, release or escape of "pollutants" or "contaminants" is caused by a "specified causes of loss"; or

2) To chemical damage to glass;

b. When a discharge, dispersal, release or escape of "pollutants" or "contaminants" results in a "specified causes of loss", the loss or damage caused by that "specified causes of loss" is a "covered" loss.

5. Loss by any "occurrence" or condition within or explosion of steam boilers, steam pipes, steam engines, or steam turbines owned or leased by you, or operated under your control. But if explosion of steam boilers, steam pipes, steam engines or steam turbines results in fire or combustion explosion, we will pay for the loss or damage caused by that fire or combustion explosion. We will also pay for loss or damage caused by or resulting from the explosion of gases or fuel within the furnace of any fired vessel or within the flues or passages through which the gases of combustion pass.

6. Hot water boilers or other water heating equipment caused by or resulting from any condition or event inside such boilers or equipment; except when such condition results from a fire or explosion. However, if a loss by a peril not otherwise excluded in this policy results, we will be liable for only such resulting loss.

Electrical or mechanical breakdown including rupture or bursting caused by centrifugal force. However, if a loss by a peril not otherwise excluded in this policy results, we will then be liable for only such resulting loss
EXCEPTION: If mechanical breakdown results in elevator collision, we will pay for the loss or damage caused by that elevator collision.

7. Nesting or infestation, or discharge or release of waste products or secretions, by insects, birds, rodents or other animals.

8. Any loss arising out of any act committed:

a. By or at the direction of an insured; and

b. With the intent to cause a loss.

9. Interruption of utility services related to overhead transmission lines or satellites

B. Loss or damage based upon or arising out of any of the following causes is excluded, whether such cause is direct or indirect. This exclusion applies even when another cause contributes concurrently or in any sequence to the loss or damage.

1. Nuclear reaction, nuclear radiation, or radioactive contamination. But if nuclear reaction or radiation, or radioactive contamination, results in fire, we will pay for the loss or damage caused by that fire.

2. Wet rot, dry rot, or "fungus". But we will pay for loss or damage caused by:

a. "specified causes of loss" that resulted from wet rot, dry rot or "fungus";

b. fire; or

c. lightning.

For causes of loss other than fire or lightning, coverage is governed by **SECTION IV – "COVERED" PROPERTY; LIMIT OF COVERAGE** Item AA. **Limited Coverage For "Fungus", Wet Rot, Dry Rot, Virus, Bacterium and Other Microorganism.**

3. Virus, Bacterium, or other microorganism, except to the extent that coverage is provided in Item AA. **Limited Coverage For "Fungus", Wet Rot, Dry Rot, Virus, Bacterium And Other Microorganism.**

4. "Flood", including spray from any "flood", whether driven by wind or not, unless otherwise provided under **SECTION IV – "COVERED" PROPERTY; LIMIT OF COVERAGE.**

5. Water below the surface of the ground including water which exerts pressure on or flows, seeps or leaks through sidewalks, driveways, foundations, walls, basements, or other floors, or through doors, windows, or any other openings in such sidewalks, driveways, foundations, walls, or floors; unless loss by fire, sprinkler leakage or explosion (not excluded in this policy) results, then we will pay for only such resulting loss.

EXCEPTION: We will provide coverage for sewer, septic system or sump pump backup that is contained within a "building" or structure.

6. War, warlike action, insurrection, rebellion, and revolution, or action taken by governmental authority in hindering or defending against any of these.

7. Failure of the insured to use all reasonable means to save and preserve property from further damage at and after the time of loss.

SECTION VII – BASIS OF RECOVERY

Replacement of property "covered" by Section IV of this policy shall be based upon "replacement cost" (without deduction for depreciation) of those items to which this policy applies unless otherwise limited by other provisions of this policy, by endorsement or the following:

A. The most we will pay for loss or damage to "covered property" other than a "historical building" shall not exceed the lesser of the following amounts:

1. The policy limits of your coverage under this agreement.

2. The amount incurred to repair or replace the damaged property at the time of loss with property of like kind and quality to be used for the same purpose on the same site.

3. The amount incurred to repair or replace the damaged property as soon as reasonably possible after the loss or damage, but within a time not to exceed two (2) years unless the time is extended in writing by us.

4. The "actual cash value" of the property at the time of loss or damage unless it is repaired or replaced subject to the following.

a. If you do not provide us with written notice of your intent to repair or replace the damaged "covered" property within 180 days of the date of loss, then you will receive "actual cash value".

b. If you receive a settlement on an "actual cash value" basis, you may make a written request within 180 days of the date of loss to repair or replace the damaged "covered" property; or

c. If there were plans for disposal or demolition of the property prior to the loss or damage, you will receive the "actual cash value" of the property at the time of loss or damage.

B. With respect to a "historical building", our liability for "covered" loss or damage shall not exceed the lesser of the following amounts:

1. The policy limits of your coverage under this agreement.

2. In the event of a total loss, the amount incurred cost to repair or replace the damaged property on the same site (or on a different site if relocation is required due to the enforcement of or compliance with an ordinance or law) with a less costly "building" that is functionally equivalent to the damaged "historical building".

3. In the event of a partial loss the amount incurred to repair or replace the damaged portion of the "covered" "historical building" with less costly material in the architectural style that existed before the loss or damage occurred but within a time not to exceed two (2) years unless the time is extended in writing by us.
4. The "actual cash value" of the property at the time of the loss or damage unless it is repaired or replaced subject to the following:
 - a. If you do not provide us with written notice of your intent to repair or replace the damaged "covered" property within 180 days of the date of loss, then you will receive "actual cash value."
 - b. If "you" receive a settlement on an "actual cash value" basis, you may make a written request within 180 days of the date of loss to repair or replace the damaged "covered" property; or.
 - c. If there were plans for disposal or demolition of the property prior to the loss or damage, you will receive the "actual cash value" of the property at the time of loss or damage.
- C. The most we will pay for diminution of value to property caused by "cosmetic damage" from a "covered" peril, shall not be more than 5% of the "actual cash value" of the damage, subject to the following:
 1. No payment shall be made under this provision if any other payment is made for any other damage associated with the insured property.
 2. Payments made under this provision shall only be paid one time per insured building, regardless of the number of occurrences during the policy period.
 3. Any payment for damages under this provision, in any prior policy period, precludes all future payments under this provision.

SECTION VIII – CONDITIONS

This policy is subject to the following conditions:

A. Other Insurance

1. If there is other insurance covering loss to the property from any peril(s) insured against under this policy, we will not be liable under this policy until such other insurance has been exhausted. We shall not be liable for payment of deductibles under other policies.

- B. Cancellation and Nonrenewal.** You may cancel this policy at any time by giving us written notice or returning the policy to us and stating at what future date coverage is to stop.

We may cancel or not renew this policy by written notice to you at the address shown on the declarations. If the notice is mailed, it will be by first class mail. Proof of delivery of mailing is sufficient proof of notice.

If this policy is in effect for less than 60 days, we may cancel you for any reason.

If this policy has been in effect 60 days or more or if it is a renewal of a policy issued by us, we may cancel or not renew only at the anniversary date unless:

1. The premium has not been paid when due;
2. We discover material misrepresentation made by you or with your knowledge in obtaining the policy, continuing the policy, or presenting a claim under the policy,
3. There has been a substantial change in risk assumed that we could not have reasonably foreseen or contemplated in writing the policy; or
4. There have been substantial breaches of contractual duties, conditions or warranties.

If we cancel this policy, we will give you notice at least ten days before cancellation is effective.

If we cancel or non-renew this policy at the anniversary date, we will give you at least 60 days' advance notice.

Your return premium, if any, will be calculated on a pro rata basis and refunded at the time of cancellation or as soon as practical. Payment or tender of the unearned premium is not a condition of cancellation.

- C. **Renewal.** If we decide to renew or amend this policy at the anniversary date with terms less favorable to you or at a higher premium, we will give you notice of the altered terms at least 60 days prior to the renewal or anniversary date. Our notice will be delivered or mailed by first class mail.

A notice is not needed if it involves a premium increase and the premium increase:

1. Is less than 25% and is generally applicable to the class of business to which this policy belongs; or
2. Results from a change based on your action that alters the nature or extent of the risk insured against, including but not limited to a change in classification or the units of exposure, or increased policy coverage.

- D. **Change in Use or Occupancy.** If your use or occupancy of any "building" or structure "covered" by this policy changes, you must notify "us" of such change in use or occupancy at renewal.

- E. **Appraisal.** In the event that you and we disagree as to the value or the amount of loss, then, on the written demand of either, each shall select a competent and disinterested appraiser and notify the other of the appraiser within twenty days of such demand. These two appraisers will then select a competent and disinterested umpire; and failing for fifteen days to agree upon such umpire, then, on request of you or we, such umpire shall be selected by a judge of a court of record in the state in which the property covered is located.

The appraisers will appraise the loss, stating separately the value and damage. Failing to agree, they will submit their differences to the umpire. A decision agreed to, in writing and filed with us, by any two will be binding. Each party will:

1. Pay its chosen appraiser; and
2. Bear the other expenses of appraisal and umpire equally.

If there is an appraisal, we still retain our right to deny the claim.

- F. **Options.** In the event of a loss or damage to "covered" property we will, at our option, decide whether to:

1. Pay based on the cost to repair or replace the damaged "covered" property; and/or
2. Retain salvage rights to the damaged "covered" property.

- G. **Abandonment.** There may be no abandonment of any property to us.

- H. **When Losses Will Be Paid.** We will pay for covered loss or damage within 30 days after we receive the Sworn Statement in Proof of Loss, provided you have complied with all of the terms of this policy, and (1) we have reached agreement with you on the amount of loss; or (2) a valid Appraisal Award has been rendered.

- I. **Loss Payable.** Loss will be adjusted with and payable to you except with regard to loss of property in which others have an insurable interest identified in this policy as owner(s), mortgagee(s), or loss payee(s), at which time the loss will be adjusted with you and payable to you and such other owner(s), mortgagee(s), or loss payee(s) as designated.

- J. **Subrogation.** Upon payment to you by us, we acquire all rights of recovery you have or may have against any party, to the extent of such payment. We will not be entitled to recover until you have been made whole. Any

waiver of subrogation made by you on or after the effective date of your resolution to insure your property through us is not binding on us and will not affect our rights of recovery against any party to the extent of any payment by us to you. However, any waiver of subrogation made by you which is in effect prior to the effective date of your resolution to insure your property through us may be given effect provided such waiver of subrogation is made in writing before the loss.

K. **Liberalization.** If we adopt any revision that would broaden the coverage provided by this policy without additional premium within 45 days prior to or during the policy period, the broadened coverage will immediately apply to this policy.

L. **Suit Against Us.** No suit to recover any loss may be brought against us unless:

1. The terms of the property coverage have been fully complied with; and
2. The suit is commenced within one year after the loss.

If any applicable law makes this limitation invalid, then suit must begin with the shortest period permitted by the law.

M. **Assignment.** Assignment of this policy will not be valid except with the written consent by us.

N. **Premium Adjustment:**

Only endorsements adding or deleting a coverage components, during the policy period, resulting in a net premium adjustment will be charged or credited to the insured. These premium adjustments will be charged or credited on a pro-rata basis from the effective date of the endorsement.

O. **No Benefit To Bailee:**

No person or organization, other than you, having custody of "covered" property will benefit from this insurance.

P. **Inspections and Surveys.** You grant us the right to have rating, advisory, rate services or similar organizations conduct insurance inspections, surveys, reports or recommendations on our behalf. However, we are not obligated to make any inspections, surveys, reports or recommendations and any such actions these organizations provide relate only to the premiums to be charged or possible improvements to your business activities.

We do not make safety inspections. We do not undertake to perform the duty of any person or organization to provide for the health or safety of workers or the public. We, or any other organization performing an inspection, survey, report or recommendation on our behalf, do not warrant that conditions are safe or healthful, or in compliance with laws, regulations, codes or standards.

Q. **Duties In The Event Of Loss or Damage**

1. You must see that the following are done in the event of loss or damage to "covered" property:
 - a. Notify the police if a law may have been broken.
 - b. Give us prompt notice of the loss or damage. Include a description of the property involved.
 - c. As soon as possible, give us a description of how, when and where the loss or damage occurred.
 - d. Take all reasonable steps to protect the "covered" property from further damage, and keep a record of your expenses necessary to protect the "covered" property, for consideration in the settlement of the claim. This will not increase the Limit of Insurance. However, we will not pay for any subsequent loss or damage resulting from a cause of loss that is not a "covered" peril. Also, if feasible, set the damaged property aside and in the best possible order for examination.

- e. At our request, give us complete inventories of the damaged and undamaged property. Include quantities, costs, values and amount of loss claimed.
- f. As often as may be reasonably required, permit us to inspect the property proving the loss or damage and examine your books and records. Also permit us to take samples of damaged and undamaged property for inspection, testing and analysis, and permit us to make copies from your books and records.
- g. Send us a signed, sworn proof of loss containing the information we request to investigate the claim. You must do this within 60 days after our request. We will supply you with the necessary forms.
- h. Cooperate with us in the investigation or settlement of the claim.
 - 1) We may examine any insured under oath, while not in the presence of any other insured and at such times as may be reasonably required, about any matter relating to this insurance or the claim, including an insured's books and records. In the event of an examination, an insured's answers must be signed.

SECTION IX – DEFINITIONS

- A. "Actual cash value" means the cost (new) to replace the structure with one of like kind and quality less physical depreciation and obsolescence as determined by Wisconsin's Broad Evidence Rule.
- B. "Builders risk property" means:
 - 1. "Buildings", structures or "Property in the Open" in the course of construction;
 - 2. "Building materials";
 - 3. Foundation of a "building", structure or "Property in the Open" in the course of construction;
 - 4. Addition to an existing "building", structure or "Property in the Open";
 - 5. Temporary structures built or assembled on the premises", including cribbing, scaffolding, signs, fences, and construction forms used in the course of construction or alterations or repairs of the "builders risk property"; and
 - 6. Underground and buried pipes, flues or drains but not including those that are part of your storm, water or sewer systems.
- C. "Building" or "buildings" means:
 - 1. Any structure that exhibits two or more of the following characteristics;
 - a. Structural walls and roof covering
 - b. Some form of permanent foundation (Post, block, slab or sub-grade)
 - c. Permanent utility services (electrical service, Heating Ventilation or air conditioning or plumbing)
 - 2. Completed additions;
 - 3. Permanently installed fixtures, machinery and equipment;
 - 4. Communication towers 100 feet or greater in height;
 - 5. Electrical substations, including control structures, transformers, distribution equipment and related structures located within the substation area;

6. Lift stations, wells or pumping locations;
 7. Permanent water storage tanks and towers;
 8. Wastewater lagoons, including: plastic, synthetic, clay or other lagoon liners, lagoon riprap and soil/subsoil embankments;
 9. Gas reduction or odorizing stations; or
 10. Underground and buried pipes, flues or drains that are part of a geothermal heating or cooling system, or part of the water treatment plant, wastewater treatment plant, lift station or gas reduction station, but not including those that are part of your storm, water or sewer systems.
- D. "Building materials" means unattached materials and supplies, fixtures and machinery, and equipment used to service the "buildings", structures or "Property in the Open" that are intended for use in the construction or occupancy of the "buildings", structures or "Property in the Open". "Building materials" also include "building materials" in the custody of the contractor or subcontractor intended for use in the construction or occupancy of the "building", structure or "Property in the Open" if not covered by other insurance.
- E. "Computer program(s)" means a sequence of instructions that performs a specific task when executed by a computer or device connected to it.
- F. "Contaminants" means mixture or contact with an impure or a foreign substance which, when introduced to the property, injures the property's usefulness.
- G. "Cosmetic Damage" means the disfiguring, blemishing, tarnishing, denting or other outward damage that changes the appearance of insured property, but does not impair its' ability to function as intended.
- H. "Covered" means insured by us under this policy.
- I. "Electronic data" means facts, information, documents, records or "computer programs" stored on, used on, or transmitted to or from electronic devices, equipment or media.
- J. "Employee(s)" means any partner, member, officer, manager, employee (including leased employees), director, trustee, or official.
- K. "Extra Expense" means the excess (if any) of the total cost incurred during a reasonable time period while the property is being restored, chargeable to your "operations", over and above the total cost that would normally have been incurred to conduct your "operations" during the same period had no damage or destruction occurred.
- L. "Fine Arts" means works of art, museum collections, limited production collectibles, historical value items, antiques or rare articles, including etchings, pictures, photographs (negatives and positives), lithographs, gallery proofs, original records, and similar property.
- M. "Flood" means a general and temporary condition of partial or complete inundation of 2 or more acres of normally dry land area or of 2 or more properties (at least 1 of which is the policyholder's property) from:
1. Overflow of inland or tidal waters; or
 2. Unusual and rapid accumulation or runoff of surface waters from any source; or
 3. Mudflow; or
 4. Collapse or subsidence of land along the shore of a lake or similar body of water as a result of erosion or undermining caused by waves or currents of water exceeding anticipated cyclical levels that result in a flood as defined above.

- N. "Fungus" means mold, mildew, or any other type of fungus, including mycotoxins, spores, odors or byproducts arising out of the current or past presence of a fungus.
- O. "Historical building" means any "building" or structure listed by the Wisconsin State Historical Society on the Wisconsin State and National register of historic places.
- P. "Money" means currency, coins, bank notes and bullion, and travelers checks, registered checks and money orders (including those held for sale to the public).
- Q. "Occurrence" means an accident, including continuous or repeated exposure to substantially the same general harmful conditions within a 72-hour period, which results in property damage during the policy period.
- R. "Operations" means the performance of your functions and duties at the insured premises.
- S. "Property in the Open" means mobile or permanently affixed personal property designed to be left exposed to the elements and outside of a covered building.
- T. "Pollutants" means largely undesirable substances, irritants, "contaminants", chemicals or waste products that interfere with human comfort or health or that adversely affect the air, soil, water or other natural resources.
- U. "Replacement Cost" means the cost to repair or replace (new) the property with like kind and quality.
- V. "Securities" means all negotiable and nonnegotiable instruments or contracts representing either "money" or other property and includes revenue stamps, food stamps, and other stamps in current use; tokens and tickets.
- W. "Sinkhole collapse" means the abrupt settlement, systematic weakening or collapse of the land supporting a covered "building" that results from simultaneous movement of soil, sediment or rock into subterranean voids created by the effect of water on a limestone or similar rock formation. "Sinkhole collapse" does not include collapse of the land into manmade underground cavities or ordinary settling or cracking of the covered "building" or its foundation.
- X. "Specified causes of loss" means the following: aircraft; civil commotion; explosion; fire; hail; leakage from fire extinguishing equipment; lightning; riot; "sinkhole collapse"; smoke; vandalism; vehicles; volcanic action; "water damage"; weight of snow, ice or sleet; windstorm. It also means falling objects, not including loss or damage to "Property in the Open" or to the interior of a "building" or its contents if the exterior of the "building" remains undamaged by the falling objects.
- Y. "Vacant" means:
 1. If you are a tenant, a unit or suite leased to you that does not house sufficient personal property to allow you to conduct your normal business "operations".
 2. If you are an owner or general lessee of a "building", less than 31 % of the total square footage of your "building" is used by an owner, a lessee, or a sub-lessee to conduct its normal business "operations".

"Buildings", units, suites or structures under construction or renovation are not considered "vacant".

A suspension of "operations" or period of inactivity during part of each year which is usual and incidental to the described occupancy of the "building", unit, suite or structure shall not be deemed "vacant".

Change of occupancy shall be recognized by us only if formal action changing the occupancy of the "building", unit, suite or structure was taken by your governing board prior to the loss.
- Z. "Valuable Records" means inscribed, printed, or written documents; manuscripts or records, including abstracts, books, deeds, drawings, films, maps, and mortgages. "Valuable Records" does not mean your accounts receivables, "money" or "securities".

AA. "Water damage" means the accidental escape of water or steam from a plumbing system, HVAC system, or appliance on your insured premises as a direct result of the breakdown or failure of that system or appliance. "Water damage" does not include accidental discharge or overflow of water from a sump system.

This policy is made and accepted subject to the foregoing provisions together with such other provisions and agreements as may be added by endorsement.

SECTION X. DEFINITION OF "CONTRACTORS EQUIPMENT"

The following items are "Contractors Equipment" and must be scheduled to have coverage in excess of the \$25,000 provided in **Section IV.J**:

Airport Equipment	Farm Equipment	Portable Equipment
Aircraft Servicing Equipment	Balers	Compactors Compressors
Fire Fighting Equipment	Combines	Excavators Generators
Snow Removal	Cultivators	Pumps Scales
Equipment	Harvesters	Stages Tanks
Asphalt/concrete Plants	Haybines	Turbines Water Blaster
All-Terrain Vehicles	Planters	Pulvi-mixers
Augerminer	Spreaders	Railroad Equipment
Back Hoes	Fork Lifts	Railroad Cars
Boats/Motors	Golf Carts	Railroad Engines
Booster Heaters	Grinders	Track Service Vehicles
Boring Machines	Hauling Equipment (off Highway)	Road Equipment
Brush Burners	End Dumps	Flushers Graders
Cement Mixers	Hoisting Machines	Oilers Scrapers
Chippers	Honey Wagons	Rollers Sweepers
Choppers	Hydraulic Breaker	Spreaders Shoulder Machines
Compaction Equipment Pneumatic	Lake Treatment Equipment	Robots
Rollers	Barges	Rock Pickers
Steel Wheel Rollers	Lake Sprayers	Road Wideners
Tamping Compactors	Weed Harvesting Equipment	Sand Blasters
Vibratory Compactors	Leaf Suckers	Seeders
Concrete Saws	Lifts	Sewer Jetters
Conveyors	Loaders	Sewer Rodders
Core Drill	Mowers	Shovels
Cranes	Mulchers	Sludge Trucks
Crack Melter	Painting Machines	Sludge Injectors
Crushing & Aggregate	Paving Equipment	Snow Grooming Equipment
Discs	Base Plants Finishers	Snow blowers
Ditchers	Distributors Mixers	Snowmobiles
Draglines	Profilers Plants	Sprayers
Drones	Rippers Screeners	Street Sweepers
Earth Moving Equipment	Spreaders Surge Bins	Stump Cutters
Crawler Loaders	Scarifiers Asphalt Heaters	Stump Pullers
Loader - Backhoes	Tar Kettles Tumblers	Surge Bins
Motor Graders	Transit Mixers	Tractors (including riding lawnmowers)
Motor Scrapers	Personal Watercraft	Trailers
Rubber-tired Loaders	Pile Driving Equipment	Tree Movers/Planters
Wheel Tractors	Pipeline Equipment	Valve Operator
End Loader Type	Plow Blades	*Vehicles
Equipment Derricks	Plow Wings	Water Wagons
Equipment Excavating		Welders
Pumps		Windrow Eliminators
Excavators		Windrower

Attachments related to the operation of the property listed above need not be scheduled. They are covered as part of the basic power unit.

*Vehicles designed for road use, but not licensed, because of specialized use. Attachments to vehicles licensed for road use such as wing blades, snowblades, and sanders are Contractors Equipment.

MUNICIPAL PROPERTY INSURANCE COMPANY

SPECIFIC LIMIT ENDORSEMENT

This endorsement supersedes the following coverage provisions of policy number 5000130 Q-1; Section III; Section IV; Section V, Paragraph J; Section VII; and Section VIII, Paragraph E.

The most that we will pay in the event of loss for the property described in this endorsement is the amount of coverage designated by the insured, as identified in the declaration page of this policy. Coverage is limited to the items promulgated in the following schedule.

Description of property - include addresses, site and building numbers as noted on Statement of Values	Building Values	Contents Values	Miscellaneous Coverage Values
1920 Stahl Rd., Sheboygan, WI 53081 - Poth Farm	100,000	0	

Miscellaneous coverages include items such as valuable papers, extra expense, pollution clean up, etc., due to losses caused by "covered" perils to property described in this endorsement. In no event shall coverage be greater than that provided in the policy to which this endorsement is attached.

Coverage does apply to buildings and structures that are vacant beyond a period of 60 consecutive days providing those structures are heated or plumbing fixtures and apparatus drained of water or other liquids to prevent loss due to freezing.

MUNICIPAL PROPERTY INSURANCE COMPANY

VACANCY PERMIT

This endorsement modifies insurance provided under:

MUNICIPAL PROPERTY INSURANCE COMPANY POLICY MPIC-001

SCHEDULE

Site.

No.

Per schedule on Declarations Page

A. We issue this Vacancy Permit subject to the following:

The following do not apply to a "covered" loss arising from "vacant" property at the locations shown on the declarations page under Vacancy Permit or in the Schedule above:

Item J. SECTION V – PROPERTY NOT COVERED UNLESS SPECIFICALLY ENDORSED TO THE POLICY of the MUNICIPAL PROPERTY INSURANCE COMPANY POLICY MPIC-001.

B. Other Policy Provisions All exclusions, limitations and other provisions of the policy to which this endorsement is attached that does not conflict with the language in this endorsement apply to this endorsement.

Any liberalized terms of this endorsement supersede the policy to which this endorsement is attached.

MUNICIPAL PROPERTY INSURANCE COMPANY

MONIES AND SECURITIES ENDORSEMENT

This endorsement modifies insurance provided under:

MUNICIPAL PROPERTY INSURANCE COMPANY POLICY MPIC-001

A. Coverage A - Loss Inside the Premises

This endorsement provides coverage to pay for loss of money, securities, and food stamps by the actual destruction, disappearance or wrongful abstraction thereof within your premises or within any banking premises or similar recognized places of safe deposit.

B. Coverage B - Loss Outside the Premises

This endorsement provides coverage to pay for loss of money, securities, and food stamps by the actual destruction, disappearance or wrongful abstraction thereof outside your premises while being conveyed by a "messenger" or any armored motor vehicle company, or while within the living quarters in the home of any "messenger".

C. Deductible See Section II of basic policy.

D. Exclusions

This endorsement does not apply:

1. To loss due to any fraudulent, dishonest or criminal act by any insured, an officer, employee, director, trustee or authorized representative thereof, while working or otherwise and whether acting alone or in collusion with others; provided, this exclusion does not apply to "safe burglary" or "robbery" or attempt thereof by other than an insured;
2. To loss due to:
 - a. The giving or surrendering of money or securities in any exchange or purchase, or
 - b. Accounting or arithmetical errors or omissions;
3. To loss of manuscripts, books of account or records;
4. Under Coverage A, to loss of money contained in coin operated amusement devices or vending machines, unless the amount of money deposited within the device or machine is recorded by a continuous recording instrument therein;
5. To loss due to war, whether or not declared, civil war, insurrection, rebellion or revolution, or to any act or condition incident to any of the foregoing;
6. To loss due to nuclear reaction, nuclear radioactive contamination, or to any act or condition incident to any of the foregoing.

E. Definitions. The following definitions apply to this endorsement:

1. "Money" means currency, coins, bank notes and bullion; and travelers checks, registered checks and money orders held for sale to the public.
2. "Securities" means all negotiable and non-negotiable instruments or contracts representing either money or other property and includes revenue stamps, food stamps, and other stamps in current use, tokens and tickets, but does not include money.

3. "Messenger" means you or any employee of yours who is authorized by you to have the care and custody of the insured property outside the premises.
4. "Custodian" means you or any employee of yours who is authorized by you to have the care and custody of the insured property within the premises, excluding any person while acting as a watchman, porter or janitor.
5. "Robbery" means the taking of insured property (1) by violence inflicted upon a "messenger" or a "custodian"; (2) by putting him/her in fear of violence; (3) by any other overt felonious act committed in his/her presence and of which he/she was actually cognizant, provided such other act is not committed by your employee; (4) from the person or direct care and custody of a "messenger" or "custodian" who has been killed or rendered unconscious; or (5) under Coverage A. (a) from within the premises by means of compelling a "messenger" or "custodian" by violence or threat of violence while outside the premises to admit a person into the premises or to furnish him with means of ingress in the premises, or (b) from a showcase or show window within the premises while regularly open for business, by a person who has broken the glass thereof from outside the premises.
6. "Safe Burglary" means (1) the felonious abstraction of insured property from within a vault or safe, the door of which is equipped with a combination lock, located within the premises by a person making felonious entry into such vault or such safe and any vault containing the safe, when all doors thereof are duly closed and locked by all combination locks thereon, provided such entry shall be made by actual force and violence, of which force and violence there are visible marks made by tools, explosives, electricity or chemicals upon the exterior of (a) all of said doors of such vault or such safe and any vault containing the safe, if entry is made through such doors, or (b) the top, bottom or walls of such vault of such safe and any vault containing the safe through which entry is made, if not made through such doors, or (2) the felonious abstraction of such safe from within the premises.
7. "Loss" includes damage.

F. Ownership of Property; Interests Covered

The insured property may be owned by you, or held by you in any capacity whether or not you are liable for the loss thereof, or may be property as respects which you are legally liable; provided, the insurance applies only to your interest in such property, including your liability to others, and does not apply to the interest of any other person or organization in any property unless included in the insured's proof of loss.

G. Books and Records

You shall keep records of all the insured property in such manner that we can accurately determine the amount of loss.

H. Limits of Liability; Settlement Options

The limit of our liability for loss shall not exceed the applicable limit of insurance stated in the declarations, nor what it would cost at the time of loss to repair or replace the property with other of like kind and quality, nor as respects securities the "actual cash value" thereof at the close of business on the business day next preceding the day on which the loss was discovered, nor as respects other property the "actual cash value" thereof at the time of loss; provided, however, the "actual cash value" of such other property held by you as a pledge, or as collateral for an advance or a loan, shall be deemed not to exceed the value of the property as determined and recorded by you when making the advance or loan, nor in the absence of such record, the unpaid portion of the advance or loan plus accrued interest thereon at legal rates.

The applicable limit of insurance stated in the declarations is the total limit of our liability with respect to all loss of property of one or more persons or organizations arising out of any one occurrence. All loss incidental to an actual or attempted fraudulent, dishonest or criminal act or series of related acts at the premises, whether committed by one or more persons, shall be deemed to arise out of one occurrence.

We may pay for the loss in money or may repair or replace the property and may settle any claim for loss of property either with you or the owner thereof. Any property so paid for or replaced shall become our property. Any property recovered after settlement of a loss shall be applied first to the expense of the parties in making such recovery, with any balance applied as if the recovery had been made prior to said settlement, and loss readjusted accordingly. You or we, upon recovery of any such property, shall give notice thereof as soon as practicable to the other.

I. Conditions See the section of the basic policy entitled **CONDITIONS**.

J. Additional Condition

Coverage Period, Territory, Discovery - This endorsement applies only to loss which occurs during the policy period within any of the States of the United States of America, the District of Columbia, or Canada, and is discovered not later than one year from the end of the policy period.

**MUNICIPAL PROPERTY INSURANCE COMPANY
PIER AND WHARF LIMITED COVERAGE ENDORSEMENT**

This endorsement modifies insurance provided under:

MUNICIPAL PROPERTY INSURANCE COMPANY POLICY MPIC-001

The following PROPERTY NOT COVERED policy provisions are replaced;

A. Item E. of **SECTION V – PROPERTY NOT COVERED, UNLESS SPECIFICALLY ENDORSED TO THIS POLICY**, of the **MUNICIPAL PROPERTY INSURANCE COMPANY MPIC-001**

by the following excluded causes of loss:

When covered under this policy:

1. Piers and wharves that are scheduled on the declarations page for loss or damage caused by:
 - a. Freezing or thawing; or,
 - b. Erosion or deterioration whether gradual or sudden.
2. Piers and wharves (not scheduled on the declarations page), bridges, dams, pavements, swimming pools and related equipment, retaining walls, bulkheads, and docks: for loss or damage caused by:
 - a. Freezing or thawing;
 - b. Impact of watercraft;
 - c. The pressure or weight of ice or water whether driven by wind or not; and,
 - d. Erosion or deterioration whether gradual or sudden.

Losses covered under this endorsement are subject to the following:

- a Coverage under this endorsement is not extended or amended by any other limit or sublimit of coverage provided under any other part of the policy or endorsements
- b A per occurrence coverage limit equal to not more than \$250,000
- c A per occurrence deductible equal to the greater off 10% of the total covered loss or \$1,000 applies regardless of any other deductible, covered loss or damage provisions

MUNICIPAL PROPERTY INSURANCE COMPANY
CONTRACTORS EQUIPMENT ENDORSEMENT

This endorsement modifies insurance provided under:

MUNICIPAL PROPERTY INSURANCE COMPANY POLICY MPIC-001

Property "Covered"

This endorsement provides coverage only for the items which are shown on the attached schedule you provided. Coverage applies regardless of the location of the property.

Perils "Covered": This endorsement insures against "covered" losses, except as limited or excluded in the following sections.

Additional Exclusion: This endorsement does not insure against loss or damage to tires or tubes unless the loss is coincidental with other loss or damage insured by this policy.

Basis of Recovery:

- (1) Replacement Cost – See Section VII of basic policy. The recovery basis for property of others shall be "actual cash value" unless you have agreed to the replacement cost basis in a written contract.

For Contractors Equipment on the statement of value, we will pay the current Replacement Cost at the time of the loss even if the value shown was higher or lower than the current value at the time of loss.

New Acquisitions/Replacements/Disposals:

- (1) Individual items which are acquired or replaced during the policy period are automatically covered with no premium charge.
- (2) Individual items which are disposed of during the policy period will not receive a premium credit.

MUNICIPAL PROPERTY INSURANCE COMPANY JOINT LOSS AGREEMENT ENDORSEMENT

This endorsement applies in the event of damage to or destruction of property at a location designated in this policy and also designated in a Boiler and Machinery Insurance Policy(ies) and there is a disagreement between the insurers with respect to:

1. Whether such damage or destruction was caused by a peril insured against by this policy or by a peril insured against by such Boiler and Machinery Insurance Policy(ies) or
2. The extent of participation of this policy and of such Boiler and Machinery Insurance Policy(ies) in a loss which is insured against, partially or wholly, by any or all of said policies.

We shall, upon written request of you, pay you one-half of the amount of the loss which is in disagreement, but in no event more than we would have paid if there had been Boiler and Machinery Insurance Policy(ies) in effect, subject to the following conditions:

The amount of the loss which is in disagreement, after making provisions for any undisputed claims payable under the said policies and after the amount of the loss is agreed upon by you and the insurers, is limited to the minimum amount remaining payable under either this or the Boiler and Machinery Policy(ies);

1. The Boiler and Machinery insurer(s) shall simultaneously pay to the insured one-half of said amount which is in disagreement;
2. The payments by the insurers hereunder and acceptance of the same by you signify the agreement of the insurers to submit to and proceed with arbitration within 90 days of such payments; the arbitrators shall be three in number, one shall be appointed by the Boiler and Machinery insurer, one shall be appointed by us, and the third appointed by consent of the other two. The decision by the arbitrators shall be binding on the insurers and judgement upon such award may be entered in any court of competent jurisdiction;
3. You agree to cooperate in connection with such arbitration but not to intervene therein;
4. The provisions of this endorsement shall not apply unless such other policy(ies) issued by the Boiler and Machinery insurance company(ies) is similarly endorsed; and
5. Acceptance by you of some payment pursuant to the provisions of this endorsement, including an arbitration award, shall not operate to alter, waive, surrender or in any way affect the rights of you against any of the insurers.

MUNICIPAL PROPERTY INSURANCE COMPANY
CAP ON LOSSES FROM CERTIFIED
ACTS OF TERRORISM

THIS ENDORSEMENT CHANGES THE POLICY. PLEASE READ IT CAREFULLY.

This endorsement modifies insurance provided under the following:

MUNICIPAL PROPERTY INSURANCE COMPANY POLICY MPIC-001

A. Cap On Certified Terrorism Losses

"Certified act of terrorism" means an act that is certified by the Secretary of the Treasury, in concurrence with the Secretary of State and the Attorney General of the United States, to be an act of terrorism pursuant to the federal Terrorism Risk Insurance Act. The criteria contained in the Terrorism Risk Insurance Act for a "certified act of terrorism" include the following:

1. The act resulted in insured losses in excess of \$5 million in the aggregate, attributable to all types of insurance subject to the Terrorism Risk Insurance Act; and
2. The act is a violent act or an act that is dangerous to human life, property or infrastructure and is committed by an individual or individuals as part of an effort to coerce the civilian population of the United States or to influence the policy or affect the conduct of the United States Government by coercion.

If aggregate insured losses attributable to terrorist acts certified under the Terrorism Risk Insurance Act exceed \$100 billion in a Program Year (January 1 through December 31) and we have met our insurer deductible under the Terrorism Risk Insurance Act, we shall not be liable for the payment of any portion of the amount of such losses that exceeds \$100 billion, and in such case insured losses up to that amount are subject to pro rata allocation in accordance with procedures established by the Secretary of the Treasury.

B. Application Of Exclusions

The terms and limitations of any terrorism exclusion, or the inapplicability or omission of a terrorism exclusion, do not serve to create coverage for any loss which would otherwise be excluded under this Policy, such as losses excluded for nuclear reaction, radiation or contamination; losses due to war, warlike action, insurrection, rebellion and revolution; or, action taken by governmental authority.

**MUNICIPAL PROPERTY INSURANCE COMPANY
COVERAGE OF COMPUTER-RELATED LOSSES ENDORSEMENT**

This endorsement modifies coverage provided under:

Municipal Property Insurance Company Policy MPIC-001

We will pay up to \$25,000 for the cost to recover or replace your "electronic data" due to loss caused by the following:

- A. Impairment of computer services through inside attack. We will pay for the actual expenses you incur due to the impairment of your operations during the "period of recovery" caused by the loss of "electronic data" due to "malicious programming" by an employee, contractor, or other authorized person to whom you have granted permission to access your computer system.
- B. Impairment of computer services through outside attack. We will pay for the actual expenses you incur due to the impairment of your operations during the "period of recovery" caused by the loss of "electronic data" due to "malicious programming" by any person to whom you have not granted permission to access your computer system.
- C. Loss of communications services. We will pay for the actual expenses you incur due to the impairment of your operations during the "period of recovery" caused by the loss of "electronic data" due to an interruption in communications services to the described premises. The interruption must result from direct physical loss or damage caused by a "covered" peril to communications transmission lines, including fiber optic transmission lines, but excluding overhead transmission lines.

This coverage does not apply to losses caused by the following:

- A. Governmental action relating to, or seizure of, the affected property.
- B. War, warlike action, insurrection, rebellion, and revolution, or action taken by governmental authority in defending against any of these.
- C. Nuclear reaction, nuclear radiation, or radioactive contamination.

The following definitions apply to this coverage:

- A. "Electronic data" means information, facts or computer programs stored as or on, created or used on, or transmitted to or from computer software (including systems and applications software), on hard or floppy disks, CD-ROMs, tapes, drives, cells, data processing devices or any other repositories of computer software which are used with electronically controlled equipment. The term computer programs, referred to in the foregoing description of electronic data, means a set of related electronic instructions which direct the operations and functions of a computer or device connected to it, which enable the computer or device to receive, process, store, retrieve or send data.
- B. "Malicious programming" means an illegal or unauthorized entry into an "electronic data" or computer system that results in the distortion, corruption, manipulation, copying, deletion, destruction or slowing down of that "electronic data" or computer system. It does not mean physical loss or damage to computers or computer systems.

- C. "Period of recovery" means the period of time that:
- a. Begins at the time of direct loss of or damage to "electronic data" caused by or resulting from any peril "covered" by this endorsement; and
 - b. Ends on the earlier of:
 - i. The date when your operations are restored, with reasonable speed and diligence, to the condition that would have existed in the absence of the loss of "electronic data"; or
 - ii. Sixty days after the date when, with reasonable speed and diligence, your computer system is restored to the functionality that existed prior to the loss.
 - c. The expiration date of this policy will not cut short the "period of recovery."

MUNICIPAL PROPERTY INSURANCE COMPANY
Tax Lien Property Coverage

This endorsement modifies insurance provided under:

MUNICIPAL PROPERTY INSURANCE COMPANY POLICY MPIC-001.

SECTION VII – BASIS OF RECOVERY is amended to include:

- E. The most we will pay for a loss of property acquired through foreclosure, tax lien, tax deed or any statutory taking process is "actual cash value". This coverage restriction eliminates all sub limits and other coverage provisions that may otherwise apply to a "covered loss".

MUNICIPAL PROPERTY INSURANCE COMPANY
Leased Property Coverage

This endorsement modifies insurance provided under:

MUNICIPAL PROPERTY INSURANCE COMPANY POLICY MPIC-001.

SECTION VII – BASIS OF RECOVERY is amended to include:

- D. The most we will pay for a loss of leased property is "actual cash value", unless the insured is contractually responsible for a different amount.

III

Res. No. _____ - 18 - 19. By Alderpersons Donohue and Sorenson.
March 18, 2019.

A RESOLUTION authorizing the appropriate City Officials to enter into a contract with Mike Koenig Construction Co., Inc. for the installation of replacement windows at Sheboygan Fire Department Station #1.

WHEREAS, the 2019 Capital Improvements Budget contemplates the replacement of forty-one (41) windows in Sheboygan Fire Department Station #1 with energy efficient, historically correct windows (the "Window Replacement"); and

WHEREAS, City Staff has obtained and reviewed competitive bids for the Window Replacement, and has determined that the low bid, submitted by Mike Koenig Construction Co., Inc. of Sheboygan, Wisconsin, meets all the requirements from the bid documents; and

WHEREAS, the Common Council of the City of Sheboygan believes that it is in the best interest of the City to award a contract to Mike Koenig Construction Co., Inc. for the Window Replacement.

NOW, THEREFORE, BE IT RESOLVED: That the Mayor and City Clerk are hereby authorized and directed to enter into a contract with Mike Koenig Construction Co., Inc., a copy of which is attached hereto and incorporated herein, for the installation of replacement windows at Sheboygan Fire Department Station #1.

BE IT FURTHER RESOLVED: That the appropriate City Officials are hereby authorized to draw funds in the amount of \$124,900.00 from 2019 Capital Improvements Fund - Fire - Building Improvement Account No. 47822100-621200 for the purchase and installation of windows, including disposal of the old units.

LHPS

I HEREBY CERTIFY that the foregoing Resolution was duly passed by the Common Council of the City of Sheboygan, Wisconsin, on the _____ day of _____, 20____.

Dated _____ 20____. _____, City Clerk
Approved _____ 20____. _____, Mayor

**AGREEMENT
BETWEEN THE CITY OF SHEBOYGAN, WISCONSIN AND
MIKE KOENIG CONSTRUCTION CO., INC.**

**REGARDING THE INSTALLATION OF REPLACEMENT WINDOWS
AT
SHEBOYGAN FIRE STATION NUMBER 1**

This Agreement (“Agreement”) is made and entered into effective this ____ day of _____, 2019 (the “Effective Date”), by and between the City of Sheboygan (the “City”), a municipal corporation, and Mike Koenig Construction Co., Inc. (“Mike Koenig Construction”).

WITNESSETH:

WHEREAS, the City is the owner of Fire Station Number 1, located at 833 New York Ave. in Sheboygan, Wisconsin (“Fire Station #1”); and

WHEREAS, in 2018 the City began a two year project to rehabilitate Fire Station #1; and

WHEREAS, as part of that rehabilitation, at this time the City wishes to replace the existing windows at Fire Station #1 with historically appropriate commercial grade fiberglass composite windows having high efficiency and operable internal blinds (“Window Replacement”); and

WHEREAS, the City issued Request for Bids # 1953-19 to obtain bids from qualified providers of the materials and services needed to complete the Window Replacement (“Services”); and

WHEREAS, the City has opened the bids, and determined that the bid from Mike Koenig Construction (“Bid”) is the lowest responsive and responsible bid for the Services; and

WHEREAS, a copy of the Bid is attached to this Agreement and incorporated herein by reference; and

WHEREAS, Mike Koenig Construction desires to provide the City with the necessary Services under the terms set forth in this Agreement.

NOW, THEREFORE, in consideration of the mutual covenants herein contained, the parties hereto agree as follows:

Article 1. Scope of Services

Mike Koenig Construction shall provide everything necessary—including, but not limited to, materials, labor, equipment, licenses, permits¹, bonds, and travel expenses—to fully and properly complete installation of forty-one (41) commercial grade replacement window units at Fire Station #1 pursuant to the manufacturers' specifications. Such information as is necessary to give a comprehensive idea of the construction contemplated are shown on the attached documents from Pella Window and Door Showroom of Green Bay, which are incorporated herein by reference.

1. Materials

All materials provided in order to complete the Services pursuant to this Agreement shall be new, newest model year, and free from defects.² Windows shall have a pre-finished interior, a maintenance free exterior and be "Dark Bronze" in color so as to match the door frames of the recently installed doors. Additionally, as provided in the Request for Bids, the windows shall meet the following criteria:

- Commercial grade and constructed of fiberglass composite
- Fixed casement with vented awning units
- Have the appearance of being "double-hung" to mimic the original look of the structure.
- All of the windows shall have the upper pane in insulated spandrel glass.
- The transom window shall be insulated spandrel glass.
- All windows shall be double or triple glazed and have an aggressive "Low E" Argon glazing
- The center of glass performance values shall be:
 - U Value = .19
 - SHGC = .25
 - UV Transmission = 4%
- Extruded aluminum historic brick-mold shall be installed around the exterior perimeter
- All first floor windows shall have fixed glass casements.
- All second floor units shall have fixed transoms with insulated spandrel glass over venting awning units.
- Second floor awning units shall be custom sized to match existing interior cased openings.
- The new windows shall be designed in such a way as to conceal the second floor's suspended ceiling grid system from visibility on the exterior.

¹ Mike Koenig Construction shall be responsible for obtaining any and all applicable City permits and paying any and all applicable permit fees prior to beginning work.

² The City reserves the right to employ an independent testing laboratory to conduct tests of materials as the City may deem necessary to assure complete compliance with the requirements of the specifications. Mike Koenig Construction shall offer full cooperation with respect to such testing.

2. Installation

Complete installation of the windows shall include any new trim and moldings necessary as a result of the installation of the replacement window units. All installation work shall be done by personnel trained and certified by the window manufacturer to install windows. It shall also include removal and disposal of all old windows at Fire Station #1, and complete restoration of any surfaces disturbed, including—but not limited to—drywall, wood trim, painted or stained surfaces, ceiling grid work, ceiling tiles, insulation, and exterior sealants. Additionally, as provided in the Request for Bids, the installation shall include the following:

- If required for removal of the existing windows and/or the installation of the new windows, existing finished oak trim on the second floor is to be removed and replaced.
- If required for removal of the existing windows and/or the installation of the new windows, existing drywall at window openings is to be removed and replaced.
- If wood trim or drywall requires removal and replacement, Mike Koenig Construction shall be responsible for all painting, staining, and finishing.
- One of the windows is a “transom” over an exterior door. The door manufacturer has provided the frame. Mike Koenig Construction shall provide and install an appropriate glass pane into the frame and install the frame into the opening.

3. Other Responsibilities

As it conducts the Services provided by this Agreement, Mike Koenig Construction shall also do the following:

- Conduct a Pre-Construction Conference, and any other conference or meeting that either Party believes is necessary or useful in ensuring the orderly administration of the work under this Agreement.
- Provide a competent supervisor and supporting technical personnel that are acceptable to the City throughout the entire installation. Change of the supervisor during the installation shall not be acceptable without prior written approval from the City.
- Report, in writing, any discrepancies found between the Contract (as defined in Article 29) and site conditions or any inconsistencies or ambiguities in the Contract. The City shall promptly correct such inconsistencies or ambiguities in writing. The City’s designated project manager is authorized to make such corrections. Work done by Mike Koenig Construction after his discovery of such discrepancy, inconsistency, or ambiguity shall be done at the risk of Mike Koenig Construction.
- Shall not deviate from the Contract (as defined in Article 29) without the written consent of the City. An unauthorized deviation shall be corrected at the expense of Mike Koenig Construction in a manner satisfactory to the City.
- At all times, keep the premises free from accumulation of waste materials or rubbish.
- At the completion of the Services, remove all waste materials, rubbish, tools, construction equipment, machinery, and surplus materials, leaving the work site in a condition comparable or better to that at the beginning of the Services.

- During Final Inspection, Mike Koenig Construction shall provide a knowledgeable representative to assist in the inspection of the completed Services for conformance with the Contract. The City shall prepare a Punch List that provides all items Mike Koenig Construction must complete prior to Final Acceptance. Any deficiencies shall be promptly and permanently corrected prior to Final Acceptance, and shall be the full responsibility of Mike Koenig Construction.

Article 2. Standard of Care

Mike Koenig Construction shall be responsible for completion of the Services in a manner consistent with that degree of care and skill ordinarily exercised by members of the same profession currently practicing under similar circumstances (“Standard of Care”). The City shall be the sole judge of the adequacy of Mike Koenig Construction’s work in meeting the Standard of Care; however, the City shall not unreasonably withhold its approval as to the adequacy of Mike Koenig Construction’s performance. Upon notice to Mike Koenig Construction and by mutual agreement between the parties, Mike Koenig Construction will, without additional compensation, correct or replace any and all Services not meeting the Standard of Care.

Mike Koenig Construction shall be solely responsible for all construction means, methods, techniques, sequences, and procedures, and for coordinating all portions of the Work under this Agreement, including materials used.

Article 3. Responsibilities of the City

The City designates Bernie Ramer as its designated project manager for purposes of this Agreement. If the City’s designated project manager deems it appropriate, the City’s designated project manager may consult with other employees of the City, or may retain an appropriate outside expert to assist with the management of this Project.

Article 4. Compensation

The City shall pay Mike Koenig Construction for all fees and expenses in an amount not to exceed One Hundred Twenty Four Thousand Nine Hundred and 00/100 Dollars (\$124,900.00). Invoices shall be sent via first class mail postage prepaid. Payment will be remitted to Mike Koenig Construction within forty-five (45) days of receipt of invoice. Mike Koenig Construction shall submit an invoice to the City on a monthly basis and shall be based on the percentage complete of the Services described in Article 1. The invoice shall be sent to:

Bernie Rammer
City of Sheboygan
828 Center Ave.
Sheboygan, Wisconsin 53081

Additional services not set forth in Article 1, or changes in the Services must be authorized in writing by the City or its designated project manager prior to such work being performed, or expenses incurred. The City shall not make payment for any unauthorized work or expenses.

The City may withhold payment, in whole or in part, to the extent necessary to protect itself from a loss on account of any of the following:

- Defective work.
- Evidence indicating the probable filing of claims by other parties against Mike Koenig Construction which may adversely affect the City.
- Failure of Mike Koenig Construction to make payments due to subcontractors, material suppliers, or employees.
- Damage to the City or a third party.

The submission of any request for payment shall be deemed a waiver and release by Mike Koenig Construction of all liens and claims with respect to the work and period to which such payment request pertains except as specifically reserved and noted on such request.

Partial payment made under this Agreement is not evidence of the proper performance by Mike Koenig Construction either in whole or in part, and no payment made by the City shall be construed to be an acceptance of defective or improper work. Acceptance of the work by the City shall occur only upon Final Payment by the City which will occur after Final Acceptance. The Parties recognize that more than 45 days may elapse between the submission of the last invoice and Final Acceptance or Final Payment. The City agrees to make reasonable efforts to schedule its Final Inspection in a timely manner and to process the Final Payment in a timely manner upon Final Acceptance. (For the avoidance of doubt, the warranties and guarantees in this Agreement shall continue to apply even after Final Payment by the City.)

Article 5. Appropriation of Funds

Notwithstanding any other provision of this Agreement, if funds for the continued fulfillment of this Agreement by the City are at any time not forthcoming or are insufficient, through failure of any entity, including the City itself, to appropriate funds or otherwise, then the City shall have the right to terminate this Agreement without penalty. The City agrees that it will make its best effort to obtain sufficient funds for the Agreement to meet its obligations hereunder in full.

Article 6. Performance and Payment Bond

Mike Koenig Construction shall, within fifteen (15) days of the approval of this Agreement by the Common Council of the City of Sheboygan, provide the City with a Performance Bond and a Payment Bond in the amount of one hundred percent (100%) of the contract amount.

Failure by Mike Koenig Construction to perform the work in a timely or satisfactory fashion may result in forfeiture of Mike Koenig Construction's Performance Bond.

If the Surety on any bond furnished by Mike Koenig Construction becomes a party to supervision or liquidation, or its right to do business in the State of Wisconsin is terminated, Mike Koenig Construction shall, within thirty (30) calendar days thereafter, substitute another bond or surety, both of which must be acceptable to the City.

Article 7. Schedule

Mike Koenig Construction shall order the windows promptly upon execution of this Agreement. It is estimated that it will take approximately forty-five (45) days from when the windows are ordered to when they will be available. It is estimated that it will take an additional one hundred twenty (120) days from the receipt of the windows to install the windows. Absent force majeure, Final Acceptance shall occur by September 30, 2019, or within such extra time as may have been allowed by a mutually agreed extension.

Mike Koenig Construction shall provide the City with a projected schedule of activities, so that the City and its representatives may plan site visits. The schedule shall include, at a minimum, the date upon which work is expected to commence, the date upon which work is expected to be completed, and the date of expected Final Installation. Mike Koenig Construction is responsible to notify the City of any changes in their activity schedule due to change in the overall construction schedule or Mike Koenig Construction's schedule.

The Parties agree that no charges or claims for damages shall be made by Mike Koenig Construction for any delays or hindrances, from any cause whatsoever, during the progress of any portion of the services specified in the Agreement. Such delays or hindrances, if any, may be compensated for by an extension of time for a reasonable period as may be mutually agreed upon between the Parties, it being understood however, that permitting Mike Koenig Construction to proceed to complete any service, or any part of the services / project, after the date to which the time of completion may have been extended shall, in no way operate as a waiver on the part of the City of any of its rights herein.

Article 8. Liquidated Damages

In the event that Mike Koenig Construction does not complete the Services by the date set forth in Article 7 (as potentially amended), there shall be deducted from any monies due or that may become due to Mike Koenig Construction, for each and every calendar day that the work remains uncompleted, a sum of One Hundred and 00/100 Dollars (\$100.00) per calendar day.

This sum shall be considered and treated not as a penalty but as fixed, agreed, and liquidated damages due the City from Mike Koenig Construction by reason of inconvenience to the public, added cost of supervision, and other items which have caused an expenditure of public funds resulting from his failure to complete the work.

Permitting Mike Koenig Construction to continue and finish the work or any part of same after the time fixed for its completion, or after the date to which the time for completion may have been extended, shall in no way be construed as a waiver on the part of the City of any of its rights under this Agreement.

Article 9. Workmanship and Quality of Materials

Mike Koenig Construction guarantees that the workmanship to complete the Services provided under this Agreement for a period of not less than three (3) years after final acceptance by the City. This guarantee shall cover the replacement of any and all parts and labor to replace any and all parts made necessary by normal usage and wear.

Mike Koenig Construction shall ensure that the windows qualify for a manufacturer's warranty of at least ten (10) years against defects when said defects are the result of normal daily usage. This warranty shall cover the replacement of any and all parts and labor to replace any and all parts made necessary by normal usage and wear.

Whenever, in any document, an article, material, or equipment is defined by describing a proprietary product, or by using the name of a manufacturer or vendor, the term "or equal" or the term "the equivalent" if not inserted, shall be implied, and it is done for the express purpose of establishing a basis of durability and efficiency and not for the purpose of limiting competition. Whenever material or equipment is submitted for approval as being equal to that specified, the submittal shall include sufficient information and data to demonstrate that the material or equipment conforms to all contractual requirements. The decision as to whether or not such material or equipment is equal to that specified shall be made by the City. The approval by the City of alternate material or equipment as being equivalent to that specified shall not in any way relieve Mike Koenig Construction of responsibility for failure of the material or equipment due to faulty design, material, or workmanship, to perform the function required by the contract documents. The City shall be the sole and final judge of equivalency.

Article 10. Safety Requirements

All materials, equipment, and supplies provided to the City must comply fully with all safety requirements set forth under state and federal law.

Mike Koenig Construction shall be responsible for the safety of employees at all times and shall provide all equipment necessary to insure their safety. Mike Koenig Construction shall ensure the enforcement of all applicable safety rules, regulations, ordinances and laws, whether federal, state, or local. Mike Koenig Construction's Superintendent of Safety shall make daily inspections upon the arrival and leaving of the site at the close of each workday.

Article 11. Open Records

Both parties understand that the City is bound by the Wisconsin Public Records Law and, as such, this contract is subject to that law. Mike Koenig Construction acknowledges that it is obligated to assist the City in retaining and producing records that are subject to Wisconsin Public Records Law, and that the failure to do so shall constitute a material breach of the contract, and that Mike Koenig Construction must defend and hold the City harmless from liability under that law. Except as otherwise authorized, those records shall be maintained for a period of seven (7) years after receipt of Final Payment under the Agreement.

Article 12. Termination

The City may terminate or suspend performance of this Agreement at the City's prerogative at any time upon written notice to Mike Koenig Construction. Mike Koenig Construction shall terminate or suspend performance of the Services on a schedule acceptable to the City and the City shall pay Mike Koenig Construction for all the Services performed up to the date that written notice is received, plus reasonable termination or suspension expenses. Upon restart, an equitable adjustment shall be made to Mike Koenig Construction's compensation and the schedule of services.

If Mike Koenig Construction defaults or fails to fulfill in a timely and proper manner its obligations pursuant to this Agreement, the City may, fifteen (15) days after written notice has been delivered to Mike Koenig Construction, and without prejudice to any other remedy it may have, make good such deficiencies and may deduct the cost thereof from the payment then or thereafter due to Mike Koenig Construction. In the alternative the City may, at its option, terminate this Agreement and take possession of the site and of all materials, equipment, tools, and construction equipment and machinery thereon owned by Mike Koenig Construction, and may finish the project by whatever method it may deem expedient. In case the expenses incurred by the City (including payments previously made to Mike Koenig Construction) shall be less than the sum which would have been payable under the Agreement if it had been completed by Mike Koenig Construction, Mike Koenig Construction shall be entitled to receive the difference. However, in case such expense shall exceed the sum which would have been payable under the Agreement, Mike Koenig Construction will be liable and shall pay to the City the amount of said excess. By taking over prosecution of the work, the City does not forfeit the right to recover damages from Mike Koenig Construction or its surety for failure to complete the work in the time specified.

Article 13. Default

If Mike Koenig Construction breaches this Agreement or fails to perform the work in an acceptable manner, it shall be considered in default. Any one or more of the following will be considered a default:

- Failure to begin the work under this Agreement within the time specified.
- Failure to perform the work with sufficient supervision, workers, equipment and materials to insure prompt completion of said work within the time limits allowed.
- Unsuitable performance of the work as determined by City.
- Neglecting or refusing to remove defective materials or failure to perform anew such work as shall have been rejected.
- Discontinuing the prosecution of the work or any part of it.
- Inability to finance the work adequately.
- If, for any other reason, Mike Koenig Construction breaches this Agreement or fails to carry on the work in an acceptable manner.

The City shall send Mike Koenig Construction a written notice of default. If Mike Koenig Construction, within a period of seven (7) days after such notice, fails to remedy the default, then the City shall have full power and authority, without violation of the Agreement, to take the

prosecution of the work out of the hands of Mike Koenig Construction, as set forth in this Agreement.

Article 14. Identity of Mike Koenig Construction

Mike Koenig Construction acknowledges that one of the primary reasons for its selection by the City to perform the Services is the qualifications and experience of Mike Koenig Construction. Mike Koenig Construction thus agrees that the Services to be performed pursuant to this Agreement shall be performed by Mike Koenig Construction. Mike Koenig Construction shall not subcontract any part of the Services without the prior written permission of the City. The City's project manager shall have the ability to provide this written permission. The City reserves the right to reject any of the Mike Koenig Construction's personnel or proposed outside professional sub-consultants, and the City reserves the right to request that acceptable replacement personnel be assigned to the project.

Article 15. Independent Contractor Status

During the entire term of this Agreement, Mike Koenig Construction shall be an independent contractor, and in no event shall any of its personnel, agents or sub-contractors be construed to be, or represent themselves to be, employees of the City. Mike Koenig Construction shall be solely responsible for the payment and reporting of all employee and employer taxes, including social security, unemployment, and any other federal, state, or local taxes required to be withheld from employees or payable on behalf of its employees.

Article 16. Indemnification

Mike Koenig Construction is responsible to the City for the acts and omissions of its employees, subcontractors, and any other persons performing any of the work under a contract with Mike Koenig Construction.

As such, Mike Koenig Construction shall indemnify, defend, and hold the City—including its Officials, Agents, and Employees—free and harmless from all liability, including, but not limited to, losses, damages, costs, attorney's fees, expenses, causes of action, claims, or judgments resulting from claimed injury, death, damage to property, or loss of use of property or any person or legal entity arising out of or in any way connected with the performance of work or work to be performed under this Agreement.

Mike Koenig Construction shall reimburse the City for any costs, expenses, judgments, and attorney's fees paid or incurred, by or on behalf of the City, its Officials, Agents, or Employees, or paid for on behalf of the City, its Officials, Agents, or Employees by insurance purchased or self-insurance provided by the City.

For the avoidance of doubt, Mike Koenig Construction shall further hold harmless the City, its Officials, Agents, and Employees from liability or claims for any injuries to or death of Mike Koenig Construction's employees (or the employees of any authorized subcontractor) arising out of or in any way connected with the work or work to be performed under this Agreement, including protection against any claim of the contractor or subcontractor for any payments under any worker's compensation law or any expenses of or any payments made by any worker's compensation

insurance carrier on behalf of said contractor or sub-contractor and the contractor shall indemnify the City for any costs, expenses, judgments, and attorney's fees with respect to any above referenced workers' compensation claims incurred or paid by the City or paid on its behalf or on behalf of its Officials, Agents, or Employees by insurance purchased or self-insurance provided by the City.

Article 17. Insurance

Mike Koenig Construction shall not commence work under this Agreement until it has obtained all insurance required under this Article. Additionally, Mike Koenig Construction shall not allow any approved subcontractor to commence work on its subcontract until the subcontractor has obtained all insurance required under this Article.

During the performance of any and all Services under this Agreement, Mike Koenig Construction shall maintain the following insurance in full force and effect, and shall provide proof of insurance to the Purchasing Agent listing the City of Sheboygan as an additional insured:

- a. Workers' Compensation Insurance – Mike Koenig Construction shall acquire and maintain, for the duration of the Agreement, Workers' Compensation Insurance that meets all statutory requirements. In the event this Agreement authorizes any work to be sublet, Mike Koenig Construction shall require any subcontractor to similarly provide Workers' Compensation Insurance in accordance with all statutory requirements.
- b. Commercial General Liability Insurance – Mike Koenig Construction shall acquire and maintain, for the duration of this Agreement, Commercial General Liability Insurance with a policy limit of at least \$1,000,000 per occurrence and \$2,000,000 in the aggregate. This Commercial General Liability Insurance policy shall include coverage for XCU hazards.
- c. Comprehensive Automobile Liability Insurance – Mike Koenig Construction shall acquire and maintain, for the duration of this Agreement, Comprehensive Automobile Liability Insurance with a policy limit of at least \$1,000,000 per occurrence.
- d. Umbrella Liability Insurance – Mike Koenig Construction shall acquire and maintain, for the duration of this Agreement, an Umbrella Liability Insurance policy with a policy limit of at least \$2,000,000 and a deductible of no more than \$10,000.

The proof of insurance referenced above shall require the insurance company to notify the City at least thirty (30) days prior to the expiration, cancellation, non-renewal, or material change in the coverage. The Certificate Holder on the proof of insurance should be listed as:

City of Sheboygan, Wisconsin
Bernard Rammer – Purchasing Agent
828 Center Ave., Suite 205
Sheboygan, Wisconsin 53081

The proof of insurance must contain an original signature.

The City is self-insured for Builder's Risk coverage on this Project. Mike Koenig Construction shall be responsible for the first \$10,000 of any claim related to Builder's Risk coverage.

Approval of the insurance by the City shall not relieve or decrease the extent to which Mike Koenig Construction may be held responsible for payment of damages resulting from Mike Koenig Construction's provision of the Services or its operations under this Agreement. If Mike Koenig Construction fails or refuses to procure or maintain the insurance required by these provisions, or fails or refuses to furnish the City the required proof that the insurance has been procured and is in force and paid for, the City shall have the right at its election to terminate the Agreement.

Article 18. Conflict of Interest

Mike Koenig Construction declares that it has no present interest, nor shall it acquire any interest, direct or indirect, which would conflict with the performance of Services under this Agreement. Mike Koenig Construction agrees that no person having any such interest shall be employed in the performance of this Agreement.

Article 19. Waiver

No failure of either party to enforce a term of this Agreement against the other shall be construed as a waiver of that term, nor shall it in any way affect the party's right to enforce that term. No waiver by any party of any term of this Agreement shall be considered to be a waiver of any other term or breach thereof.

Article 20. Severability

The invalidity, illegality or unenforceability of any provision of this Agreement or the occurrence of any event rendering any portion or provision of this Agreement void shall in no way affect the validity or enforceability of any other portion or provision of this Agreement. Any void provision shall be deemed severed from this Agreement, and the balance of the Agreement shall be construed and enforced as if it did not contain the particular provision held to be void. The parties further agree to amend this Agreement to replace any stricken provision with a valid provision that comes as close as possible to the intent of the stricken provision. The provisions of this Article shall not prevent this entire Agreement from being void should a provision which is of the essence of this Agreement be determined void.

Article 21. Assignment

Neither the City nor Mike Koenig Construction shall assign any rights or duties under this Agreement without the prior written consent of the other party.

Article 22. Third Party Rights

Nothing in this Agreement shall be construed to give any rights or benefits to anyone other than the City and Mike Koenig Construction.

Article 23. Governing Law and Venue

This Agreement shall be governed by the laws of the State of Wisconsin. Venue of any disputes arising under this Agreement shall be in the Sheboygan County Circuit Court, Wisconsin.

Article 24. Non-Discrimination

In connection with the performance of work under this Agreement, Mike Koenig Construction agrees not to discriminate against any employee or applicant for employment because of age, race, religion, color, handicap, sex, physical condition, developmental disability (as defined in Wis. Stat. 51.01(5)), sexual orientation (as defined in Wis. Stat. 111.32(13m)), or national origin. This provision shall include, but not be limited to, the following: employment, upgrading, demotion or transfer, recruitment or recruitment advertising, layoff or termination, rates of pay or other forms of compensation, and selection for training, including apprenticeship. Mike Koenig Construction further agrees to take affirmative action to ensure equal employment opportunities.

Article 25. Compliance with Laws

In performing the Services under this Agreement, Mike Koenig Construction shall comply with any and all applicable federal, state and local statutes, ordinances, plans, and regulations.

The City reserves the right to cancel this Agreement if Mike Koenig Construction fails to follow the requirements of Wis. Stat. 77.66 and related statutes regarding certification for collection of sales and use tax. The City also reserves the right to cancel this Agreement with any state or federally debarred contractor.

Mike Koenig Construction shall have any and all licenses and permits required to perform the work specified, and shall furnish proof of such licensing authorization and permits upon request.

Article 26. Notices

Any notice required by this Agreement shall be made in writing to the individuals/addresses specified below:

City:

Mike Koenig Construction:

City Clerk	Michael R. Koenig
City of Sheboygan	Mike Koenig Construction Co., Inc.
828 Center Ave.	3502 Behrens Parkway
Sheboygan, Wisconsin 53083	Sheboygan, Wisconsin 53081

Nothing contained in this Article shall be construed to restrict the transmission of routine communications between representatives of the City and Mike Koenig Construction.

Article 27. Intent to be Bound

The City and Mike Koenig Construction each binds itself and its successors, executors, administrators, permitted assigns, legal representatives and, in the case of a partnership, its partners to the other party to this Agreement, and to the successors, executors, administrators, permitted assigns, legal representatives and partners of such other party in respect to all provisions of this Agreement.

Article 28. Force Majeure

Neither party shall be in default by reason of any failure in performance of this Agreement in accordance with reasonable control and without fault or negligence on their part. Such causes may include, but are not restricted to, acts of nature or the public enemy, acts of the government in either its sovereign or contractual capacity, fires, floods, epidemics, quarantine restrictions, strikes, freight embargoes, and unusually severe weather. In every case, the failure to perform must be beyond the reasonable control and without the fault or negligence of the party.

Article 29. Integration and Modification

This Agreement may be modified only by a written amendment signed by both parties hereto.

This Agreement consists of the following parts, each of which is as fully a part of this Agreement as if fully set out herein:

1. This Agreement and its Attachments
2. Any Written Amendment to the Agreement which may be delivered or issued after the Effective Date of the Agreement (including Change Orders)
3. Notice of Award
4. The Request for Bids (including all attachments)
5. All Addenda to the Request for Bids
6. Mike Koenig Construction's Bid Response (including the Items to be Attached)
7. All Other Submittals by Mike Koenig Construction
8. The Performance and Payment Bonds

(collectively "the Contract").

This Contract is the entire and integrated agreement between the City and Mike Koenig Construction regarding the subject matter of this Contract. It supersedes all prior and contemporaneous communications, representations and agreements that are not part of this Contract.

In resolving conflicts, errors, discrepancies and disputes concerning the Scope of Work to be performed by Mike Koenig Construction, the document expressing the greater quantity, quality, or other scope of work in question, or imposing the greater obligation upon Mike Koenig Construction and affording the greater right or remedy to the City shall govern. Otherwise, the documents shall be given precedence in the order set forth above.

Article 30. Non-Collusion

Mike Koenig Construction is certifying, under penalty of perjury, that to the best of its knowledge and belief:

1. The prices in its bid were arrived at independently, without collusion, consultation, communication, or agreement, for the purpose of restricting competition as to any other matter relating to such prices with any other bidder, or with any other competitor.

2. The prices quoted in its bid were not knowingly disclosed—directly or indirectly—by the bidder prior to bid opening.
3. No attempt was made to induce any other person, partnership, or corporation to submit or not submit a bid for the purpose of restricting competition.

Article 31. Other Provisions

1. **Material Safety Data Sheet.** If any item(s) on an order(s) resulting from this Agreement is a hazardous chemical, as defined under 29 C.F.R. 1910.1200, Mike Koenig Construction shall provide one (1) copy of a Material Safety Data Sheet for each item with the shipped container(s) and one (1) copy with the invoice(s).
2. **Advertising and News Releases.** Reference to or use of the City, or any of its departments, officials, or employees, for commercial promotion is prohibited. News releases pertaining to this procurement shall not be made without prior approval of the City. Release of broadcast e-mails pertaining to this procurement shall not be made without prior written authorization of the City.
3. **Foreign Corporation.** A foreign corporation (any corporation other than a Wisconsin corporation) which becomes a party to this Agreement is required to conform to all the requirements of Wis. Stat. 180 relating to a foreign corporation, and must possess a certificate of authority from the Wisconsin Department of Financial Institutions, unless the corporation is transacting business in interstate commerce or is otherwise exempt from the requirement of obtaining a certificate of authority.
4. **Authority.** Each person executing this Agreement on behalf of a party hereto represents and warrants to the other party: That the execution and delivery of this Agreement has been duly authorized, that the person or persons executing this Agreement have the full power, authority, and right to do so, and that such execution is sufficient and legally binding on such party to enable this Agreement to be enforceable in accordance with its terms.
5. **Definitions.**
 - a. **Final Acceptance:** The event that occurs when Mike Koenig Construction issues to the City or the City issues to Mike Koenig Construction a written statement that Mike Koenig Construction has completed all Punch List items, has made all necessary submittals to the City, and has satisfied all of its obligations under the Agreement.
 - b. **Final Inspection:** The inspection conducted by the City to determine what work must still be completed by Mike Koenig Construction in order for Completion of the Services to occur. After the Final Inspection, the City shall provide Mike Koenig Construction with a Punch List that Mike Koenig Construction must complete in order for Completion of the Services to occur.

- c. Final Payment: Payment by the City to Mike Koenig Construction after Completion of the Services the result of which is Mike Koenig Construction receiving all payments due under the terms of the Agreement for performing and completing the Services.

IN WITNESS WHEREOF, the parties hereto have caused this Agreement to be executed the day and year first written above.

CITY OF SHEBOYGAN, WISCONSIN

MIKE KOENIG CONSTRUCTION

BY: _____
Michael J. Vandersteen, Mayor

BY: _____

ATTEST: _____
Meredith DeBruin, City Clerk

ATTEST: _____

DATE: _____

DATE: _____

BID SUBMISSION FORM

We propose to remove and dispose of the existing windows, provide and completely install 41 new windows identified below at Fire Station # 1, Sheboygan, WI 53081 to include all labor, travel, tools, equipment, materials, disposal of old windows, all permits and bonding and complete restoration of any surfaces disturbed during the project as follows:

MANUFACTURER NAME: Pella

MANUFACTURER MODEL NAME/NUMBER: Impervia

TOTAL BASE BID: \$ \$124,900.00

The Base Bid above shall include all costs associated with the project including the rental or use of man-lifts to access the mounting locations if needed.

ADDENDUM INFORMATION (If Applicable)

Receipt of the addendum listed below is acknowledged and the proposals incorporate all requirements of this addendum:

Addendum No. 1 Dated 2/16/2019

_____ Dated _____

_____ Dated _____

If awarded the contract we would expect to begin installation of the system within 45 days following receipt of the City's Purchase Order and present the City with a completed project within 120 days following start of installation.

I agree to abide by all conditions of this Bid and certify that I am authorized to sign this Bid.

Complete Legal Name of Firm: Mike Koenig Construction Co., Inc.

Address: 3502 Behrens Parkway

Sheboygan, WI 53081

Signature: 

Name (type/print): Richard Peterson

Title: Project Manager

Telephone : (920) 457-0923 Fax: (920) 457-1024

Email richardp@mikekoenigconstruction.com

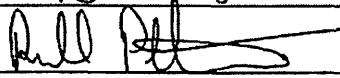
Date Signed 

Items to be attached:

- Manufacturer Cut Sheets**
- Manufacturer Warranties**
- Certification of installer training by window manufacturer**
- References**
- Energy efficiency certifications**



Proposal - Detailed

Pella Window and Door Showroom of Green Bay
 500 Pilgrim Way
 Green Bay, WI 54304
 Phone: (920) 435-3791 Fax: (920) 435-0377

Sales Rep Name: Coleman, Rob
 Sales Rep Phone: (920) 431-8921
 Sales Rep E-Mail: rcoleman@pellawi.com
 Sales Rep Fax:

Customer Information	Project/Delivery Address	Order Information
408 - Rob Coleman 500 Pilgrim Way GREEN BAY, WI 54304 Primary Phone: Mobile Phone: Fax Number: E-Mail: Contact Name: Great Plains #: Customer Number: 1003909138 Customer Account: 1001000724	Sheboygan Fire Station #1 833 New York Ave Lot # Sheboygan, WI 53081 County: Owner Name: Owner Phone:	Quote Name: Impervia 2-22-19 Order Number: 408 Quote Number: 9923428 Order Type: Non-Installed Sales Wall Depth: Payment Terms: Net 30 Days Tax Code: Cust Delivery Date: None Quoted Date: 3/12/2018 Contracted Date: Booked Date: Customer PO #:

Line #	Location:	Attributes	Qty
--------	-----------	------------	-----

10 None Assigned

Impervia, Direct Set Fixed Frame Rectangle, 40 X 101, Brown

12

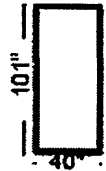

PK #
2028

1: 40101 Fixed Frame Direct Set
 Frame Size: 40 X 101
 General Information: Standard, Duracast®, Block, No Foam Insulated, 3", 1 5/16", 1 11/16"
 Exterior Color / Finish: Brown
 Interior Color / Finish: Brown
 Glass: Insulated Tempered Low-E SunDefense™ Low-E Insulating Glass Argon Non High Altitude
 Performance Information: U-Factor 0.26, SHGC 0.24, VLT 0.56, CPD PEL-N-127-02253-00001, Performance Class CW, PG 50, Calculated Positive DP Rating 50, Calculated Negative DP Rating 50, Year Rated 08
 Grille: No Grille,
 Wrapping Information: Standard Fin, No Exterior Trim, Pella Recommended Clearance, Perimeter Length = 282".

Viewed From Exterior
 Rough Opening: 40 - 1/2" X 101 - 1/2"

ROSJELJP004 - RS Loose Jamb Pine for 7 5/16 - 8 1/4 wall depth Qty 24
 TVAJA001 - VHI finish - jambs Qty 24

Line #	Location:	Attributes
--------	-----------	------------

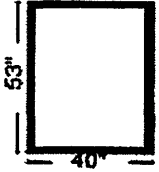
15	None Assigned	<p>Impervia, Direct Set Fixed Frame Rectangle, 40 X 53, Brown</p> <p style="text-align: right;"><u>Qty</u> 1</p>
	 <p>PK # 2028</p> <p>Viewed From Exterior Rough Opening: 40 - 1/2" X 53 - 1/2"</p>	<p>1: 4053 Fixed Frame Direct Set Frame Size: 40 X 53 General Information: Standard, Duracast®, Block, No Foam Insulated, 3", 1 5/16", 1 11/16" Exterior Color / Finish: Brown Interior Color / Finish: Brown Glass: Insulated Low-E SunDefense™ Low-E Insulating Glass Argon Non High Altitude Performance Information: U-Factor 0.27, SHGC 0.24, VLT 0.57, CPD PEL-N-127-02248-00003, Performance Class CW, PG 50, Calculated Positive DP Rating 50, Calculated Negative DP Rating 50, Year Rated 08 Grille: No Grille, Wrapping Information: Standard Fin, No Exterior Trim, Pella Recommended Clearance, Perimeter Length = 186".</p>
		<p>ROSJELJP004 - RS Loose Jamb Pine for 7 5/16 - 8 1/4 wall depth Qty 16</p> <p>TVAJA001 - VHI finish - jambs Qty 16</p>

Line #	Location:	Attributes
--------	-----------	------------

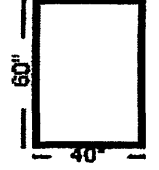
20	None Assigned	<p>Impervia, Direct Set Fixed Frame Rectangle, 40 X 60, Brown</p> <p style="text-align: right;"><u>Qty</u> 1</p>
	 <p>PK # 2028</p> <p>Viewed From Exterior Rough Opening: 40 - 1/2" X 60 - 1/2"</p>	<p>1: 4060 Fixed Frame Direct Set Frame Size: 40 X 60 General Information: Standard, Duracast®, Block, No Foam Insulated, 3", 1 5/16", 1 11/16" Exterior Color / Finish: Brown Interior Color / Finish: Brown Glass: Insulated Low-E SunDefense™ Low-E Insulating Glass Argon Non High Altitude Performance Information: U-Factor 0.27, SHGC 0.24, VLT 0.57, CPD PEL-N-127-02248-00003, Performance Class CW, PG 50, Calculated Positive DP Rating 50, Calculated Negative DP Rating 50, Year Rated 08 Grille: No Grille, Wrapping Information: Standard Fin, No Exterior Trim, Pella Recommended Clearance, Perimeter Length = 200".</p>
		<p>ROSJELJP004 - RS Loose Jamb Pine for 7 5/16 - 8 1/4 wall depth Qty 17</p> <p>TVAJA001 - VHI finish - jambs Qty 17</p>

For more information regarding the finishing, maintenance, service and warranty of all Pella® products, visit the Pella® website at www.pella.com

Line #	Location:	Attributes
--------	-----------	------------

25 None Assigned

Impervia, Large Awning, Impervia, Direct Set Fixed Frame Rectangle, 40 X 86, Brown

Qty

27

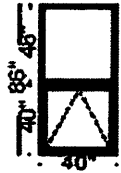

PK #
2028

1: Non-Standard Size Non-Standard Size Vent Awning

Frame Size: 40 X 40

General Information: Standard, Duracast®, Block, No Foam Insulated, 3 1/4", 1 15/16"

Exterior Color / Finish: Brown

Interior Color / Finish: Brown

Glass: Insulated Tempered Low-E SunDefense™ Low-E Insulating Glass Argon Non High Altitude

Hardware Options: Top Pivot Hardware, Fold-Away Crank, Brown, No Limited Opening Hardware, Sill

Screen: Full Screen, InView™

Performance Information: U-Factor 0.28, SHGC 0.20, VLT 0.45, CPD PEL-N-151-00730-00003, Performance Class LC, PG 50, Calculated Positive DP

Rating 50, Calculated Negative DP Rating 50, Year Rated 11, Egress Not Applicable

Grille: No Grille,

Horizontal Mull 1: FactoryMull, Standard Joining Mullion, Frame To Frame Width- 0", Mull Design Pressure- 20

2: 4046 Fixed Frame Direct Set

Frame Size: 40 X 46

General Information: Standard, Duracast®, Block, No Foam Insulated, 3", 1 11/16"

Exterior Color / Finish: Brown

Interior Color / Finish: Brown

Glass: Insulated Tempered Spandrel Air Filled Non High Altitude

Performance Information: CPD Not Rated, Performance Class CW, PG 50, Calculated Positive DP Rating 50, Calculated Negative DP Rating 50, Year

Rated 08

Grille: No Grille,

Wrapping Information: No Exterior Trim, Pella Recommended Clearance, Perimeter Length = 252", Glazing Pressure = 205.

ROSJELJP004 - RS Loose Jamb Pine for 7 5/16 - 8 1/4 wall depth

Qty 22

TVAJA001 - VHI finish - jambs

Qty 22

Line #	Location:	Attributes
--------	-----------	------------

30

Spandrel Glass for 1st Floor Door Transom

Qty

1

Line #	Location:	Attributes	Qty
35	Install Clips	00NL0000 - 6" Installation Clips (100)	<u>7</u>

Line #	Location:	Attributes	Qty
40	Frame Expander	4" Frame Expander, Length: 96, Brown	<u>93</u>
	PK # 2002	1: Accessory Frame Size: 1 X 1 General Information: 4" Frame Expander Exterior Color / Finish: Painted, Standard Enduraclad, Brown Wrapping Information: Perimeter Length = 0".	
	Viewed From Exterior		
	Rough Opening:		

Line #	Location:	Attributes	Qty
45	Frame Expander	4" Frame Expander, Length: 144, Brown	<u>30</u>
	PK # 2002	1: Accessory Frame Size: 1 X 1 General Information: 4" Frame Expander Exterior Color / Finish: Painted, Standard Enduraclad, Brown Wrapping Information: Perimeter Length = 0".	
	Viewed From Exterior		
	Rough Opening:		

Line #	Location:	Attributes	Qty
50		Staright & Curved Historic Aluminum Brickmould & Clips	1

Thank You For Your Interest In Pella® Products

PELLA WARRANTY:

Pella products are covered by Pella's limited warranties in effect at the time of sale. All applicable product warranties are incorporated into and become a part of this contract. Please see the warranties for complete details, taking special note of the two important notice sections regarding installation of Pella products and proper management of moisture within the wall system. Neither Pella Corporation nor the Seller will be bound by any other warranty unless specifically set out in this contract. However, Pella Corporation will not be liable for branch warranties which create obligations in addition to or obligations which are inconsistent with Pella written warranties.

Clear opening (egress) information does not take into consideration the addition of a Rolscreen [or any other accessory] to the product. You should consult your local building code to ensure your Pella products meet local egress requirements.

Per the manufacturer's limited warranty, unfinished mahogany exterior windows and doors must be finished upon receipt prior to installing and refinished annually, thereafter. Variations in wood grain, color, texture or natural characteristics are not covered under the limited warranty.

INSYNCTIVE PRODUCTS: In addition, Pella Insynctive Products are covered by the Pella Insynctive Products Software License Agreement and Pella Insynctive Products Privacy Policy in effect at the time of sale, which can be found at Insynctive.pella.com. By installing or using Your Insynctive Products you are acknowledging the Insynctive Software Agreement and Privacy Policy are part of the terms of sale.

ARBITRATION AND CLASS ACTION WAIVER ("ARBITRATION AGREEMENT")

YOU and Pella and its subsidiaries and the Pella Branded Distributor AGREE TO ARBITRATE DISPUTES ARISING OUT OF OR RELATING TO YOUR PELLA PRODUCTS (INCLUDES PELLA GOODS AND PELLA SERVICES) AND WAIVE THE RIGHT TO HAVE A COURT OR JURY DECIDE DISPUTES. YOU WAIVE ALL RIGHTS TO PROCEED AS A MEMBER OR REPRESENTATIVE OF A CLASS ACTION, INCLUDING CLASS ARBITRATION, REGARDING DISPUTES ARISING OUT OF OR RELATING TO YOUR PELLA PRODUCTS. You may opt out of this Arbitration Agreement by providing notice to Pella no later than ninety (90) calendar days from the date You purchased or otherwise took ownership of Your Pella Goods. To opt out, You must send notice by e-mail to pellawebssupport@pella.com, with the subject line: "Arbitration Opt Out" or by calling (877) 473-5527. Opting out of the Arbitration Agreement will not affect the coverage provided by any applicable limited warranty pertaining to Your Pella Products. For complete information, including the full terms and conditions of this Arbitration Agreement, which are incorporated herein by reference, please visit www.pella.com/arbitration or e-mail to pellawebssupport@pella.com, with the subject line: "Arbitration Details" or call (877) 473-5527. D'ARBITRAGE ET RENONCIATION AU RECOURS COLLECTIF ("convention d'arbitrage") EN FRANÇAIS SEE PELLA.COM/ARBITRATION. DE ARBITRAJE Y RENUNCIA COLECTIVA ("acuerdo de arbitraje") EN ESPAÑOL VER PELLA.COM/ARBITRATION.

Product Performance Information:

U-Factor, Solar Heat Gain Coefficient (SHGC), and Visible Light Transmittance (VLT) are certified by the National Fenestration Rating Council (NFRC). Manufacturer stipulates that these ratings conform to applicable NFRC procedures for determining whole product performance. NFRC ratings are determined for a fixed set of environmental conditions and a specific product size. NFRC does not recommend any products and does not warrant the suitability of any product for any specific use.

Design Pressure (DP), Performance Class, and Performance Grade (PG) are certified by a third party organization, in many cases the Window and Door Manufacturers Association (WDMA). The certification requires the performance of at least one product of the product line to be tested in accordance with the applicable performance standards and verified by an independent party. The certification indicates that the product(s) of the product line passed the applicable tests. The certification does not apply to mulled and/or product combinations unless noted. Actual product results will vary and change over the products life.

For more performance information along with information on Florida Product Approval System (FPAS) Number and Texas Dept. of Insurance (TDI) number go to www.pella.com/performance.

BRANCH WARRANTY:

For more information regarding the finishing, maintenance, service and warranty of all Pella® products, visit the Pella® website at www.pella.com

NOTICE OF LIEN RIGHTS

As required by the Wisconsin construction lien law, VerHalén, Inc DBA Pella Windows and Doors of Wisconsin hereby notifies owner that persons or companies furnishing labor or materials for the construction on owner's land may have lien rights on owner's land and buildings if not paid. Those entitled to lien rights, in addition to VerHalén, Inc DBA Pella Windows and Doors of Wisconsin, are those who contract directly with the owner or those who give the owner notice within 60 days after they first furnish labor or materials for the construction. Accordingly, owner probably will receive notices from those who furnish labor or materials for the construction and should give a copy of each notice received to the owner's mortgage lender, if any. VerHalén, Inc DBA Pella Windows and Doors of Wisconsin agrees to cooperate with the owner and the owner's lender, if any, to see that all potential lien claimants are duly paid.

TERMS & CONDITIONS:

PERFORMANCE: Where no specific date is fixed we shall be allowed reasonable time to make delivery of the materials and perform the work.

DAMAGE, LOSS, DELAY OR DEFAULT THROUGH CAUSES BEYOND OUR CONTROL: We shall not be responsible for default, damage, loss or delay in performance due to labor trouble, fires, accidents, floods, collapse or other causes beyond our control, or due to shortages of materials or transportation facilities resulting from war, national or local emergency, riots, governmental priorities, embargoes and like conditions and regulations. Any and all loss of, or damage to our materials erected or stored on the premises, not caused by us, shall be repaired and replaced by us and the additional cost thereof shall be borne by the purchaser.

WORKING CONDITIONS AND FACILITIES TO BE SUPPLIED BY THE PURCHASER: The purchaser shall make all work surfaces, on which materials are to be supplied, available for work at one time so that the work shall not be interrupted; shall provide surfaces that are clean, dry and in an accessible condition, shall at his own expense cause all obstructions to our work to be removed; shall additionally bear the cost of sending our men to the job, on his notification, before surfaces are ready for the application of our materials, or expense due to any delay during the progress of the work not caused by us; shall allow us free and reasonable use of light, heat, water and power, and the use of available elevators, hoists and other facilities.

DELIVERY: When materials are quoted on the basis of delivery to the jobsite, we provide delivery assistance to the customer's garage only.

INSURANCE: We carry public liability, property damage and workmen's compensation insurance and consequently will not honor any charges against us for such similar coverage. Any expense incurred by us for insurance or bond to cover our liability under any "hold harmless" or "indemnity" clause or clause of a similar nature in any contract, specifications, letter of acceptance or notice submitted by you or your contractors which in any way requires us to assume any liability which is not imposed on us by law, shall be paid by you.

CHANGES IN PLANS OR SPECIFICATIONS: No credit or allowance shall be granted for alterations or modifications in work or materials, unless such credit or allowance has been agreed to by us in writing before such alterations or modifications are made.

GLAZING: Attention is directed to the Consumer Product Safety Act and the Federal Regulation for "Architectural Glazing Materials (16 CFR 1201)." THIS LAW SPECIFIES WHERE THE USE OF TEMPERED GLASS IS MANDATORY. In any instances of claims arising from the use of non-tempered glass, it will be the sole liability of the contractor or customer who accepted the glass as specified in our proposal that the use of such non-tempered glass is not prohibited by law, and that this glass will be used in areas in which non-tempered glass is allowable. Distortion in tempered glass is common and is not considered a defect.

TAXES: Any sales, excise, processing or any other direct tax imposed upon the distributor, sale or application of materials supplied in accordance with this proposal shall be added to the proposal price.

CONSEQUENTIAL DAMAGE: Seller shall not be liable for any direct, indirect or consequential damage or loss for any reasons, including but not limited to: any defect or defects in materials, improper installation, or breakage, bursting leakage.

ACCEPTANCE OF WORK AND MATERIALS: The Customer shall immediately upon delivery inspect all material. All work performed and materials supplied under this Proposal shall be deemed to comply with all terms of the Proposal unless Seller is notified to the contrary within seven (7) days following delivery.

AUTHORIZATION TO USE PHOTOGRAPHS AND/OR PROJECT DETAILS: I hereby authorize Pella Corporation, its affiliates and/or subsidiaries to use, reproduce, and/or publish photographs and/or video that may pertain to me and my project, including materials described below, without compensation. I understand that this material may be used in various communications (e.g. Website, e-newsletters, promotional materials, etc).

Consequently, the Corporation may publish materials, photographs, and/or make reference to the project in a manner that the Corporation or project sponsor deems appropriate.

DEFAULTS: If the customer fails to pay pursuant to the terms of this accepted proposal, the Customer agrees to pay all reasonable attorney fees and costs (of whatever nature) incurred by the Seller to obtain collection.

CANCELLATIONS AND/OR CHANGES: All sales are final. Product is ordered based on customer specification and approval via the signed contract.

WARRANTY: Pella products are covered by Pella's limited warranties in effect at the time of sale. All applicable product warranties are incorporated into and become a part of this contract. Please see

For more information regarding the finishing, maintenance, service and warranty of all Pella® products, visit the Pella® website at www.pella.com

Customer: 408 - Rob Coleman

Project Name: Sheboygan Fire Station #1

Quote Number: 9923428

the warranties for complete details, taking special note of the two important notice sections regarding installation of Pella products and proper management of moisture within the wall system. Neither Pella Corporation nor VerHalén, Inc. DBA Pella Windows and Doors of Wisconsin will be bound by any other warranty unless specifically set out in this contract. However, Pella Corporation will not be liable for branch warranties which create obligations in addition to or obligations which are inconsistent with Pella written warranties.

Clear opening (egress) information does not take into consideration the addition of a Rolscreen (or any other accessory) to the product. You should consult your local building code to ensure your Pella products meet local egress requirements.

For more information regarding the finishing, maintenance, service and warranty of all Pella® products, visit the Pella® website at www.pella.com

For more information regarding the finishing, maintenance, service and warranty of all Pella® products, visit the Pella® website at www.pella.com

PRODUCT PERFORMANCE

GLAZING
Center of Glass Performance

CENTER OF GLASS PERFORMANCE COMPARISON GUIDE

This chart is an overview of the typical glass types that are available from Pella. The types of glass and the glass thickness vary by brand. For complete Glazing Performance data, including Obscure and High Altitude₂ glazing, please go to the appropriate product section of www.PellaADM.com.

TYPE OF GLAZING	Glass Thickness	U-Factor	Solar Heat Gain Coefficient (SHGC)	Shading Coefficient (SC)	Relative Heat Gain	% Visible Light Transmission	Inside Glass Surface Temp (°F)	% Relative Humidity @70°F when condensation appears on room side	% UV Transmission	LBL Damage Function	Low-E Coating on Surfaces #
Dual-Pane Insulating Glass, Argon filled 1 1/16" overall thickness											
Clear (air filled)	3mm ₁	0.48	0.78	0.89	186	82	44	39	58	0.61	
SunDefense™ Low-E	3mm ₁	0.24	0.27	0.31	66	65	56	61	5	0.21	2
Advanced Low-E	3mm ₁	0.25	0.37	0.42	88	70	56	61	14	0.31	2
AdvancedComfort Low-E	3mm ₁	0.20	0.36	0.42	66	69	47	44	14	0.31	2,4
NaturalSun Low-E	3mm ₁	0.26	0.68	0.79	161	79	55	59	29	0.42	3 or 2*
Bronze Advanced Low-E	5mm/3mm	0.25	0.33	0.38	79	45	56	61	7	0.19	3
Gray Advanced Low-E	5mm/3mm	0.25	0.30	0.34	73	39	56	61	7	0.18	3
Green Advanced Low-E	5mm/3mm	0.25	0.32	0.37	77	55	56	61	5	0.19	3
Advanced Laminated Low-E	3mm/6mm	0.31	0.37	0.42	89	68	53	55	0	0.20	2 or 3**
SunDefense™ Laminated Low-E	3mm/6mm	0.31	0.28	0.32	68	63	53	55	0	0.16	2 or 3**
Dual-Pane Insulating Glass, Argon filled 1" overall thickness											
Clear (air filled)	6mm	0.49	0.75	0.87	181	82	46	41	54	0.58	
SunDefense Low-E	6mm	0.25	0.27	0.31	65	63	56	61	4	0.20	2
Advanced Low-E	6mm	0.25	0.35	0.41	84	68	56	61	13	0.30	2
AdvancedComfort Low-E	6mm	0.20	0.35	0.40	82	66	47	44	12	0.29	2,4
NaturalSun Low-E	6mm	0.26	0.64	0.74	150	77	55	59	24	0.38	3 or 2*
Bronze Advanced Low-E	6mm	0.25	0.30	0.34	71	40	56	61	6	0.16	3
Gray Advanced Low-E	6mm	0.25	0.27	0.31	64	34	56	61	6	0.16	3
Green Advanced Low-E	6mm	0.25	0.29	0.33	69	51	56	61	4	0.17	3
Advanced Laminated Low-E	5mm/10mm	0.25	0.36	0.41	85	67	56	61	0	0.17	2 or 3**
SunDefense™ Laminated Low-E	5mm/10mm	0.24	0.27	0.31	66	62	56	61	0	0.14	2 or 3**
1" Triple-Pane Insulating Glass—Pella 250 Series											
Advanced Low-E	3mm	0.16	0.31	0.36	74	55	60	71	4	0.19	2,5
NaturalSun Low-E	3mm	0.17	0.56	0.64	131	70	60	71	13	0.29	2,5
Advanced Low-E	4mm	0.19	0.31	0.35	73	53	59	68	4	0.19	2,5
NaturalSun Low-E	4mm	0.20	0.54	0.62	127	69	59	68	12	0.28	2,5
1-1/4" Triple-Pane Insulating Glass—Pella 350 Series											
Advanced Low-E	3mm ₂	0.13	0.31	0.36	73	55	62	76	4	0.19	2,5
NaturalSun Low-E	3mm ₂	0.14	0.56	0.64	131	70	62	76	13	0.29	2

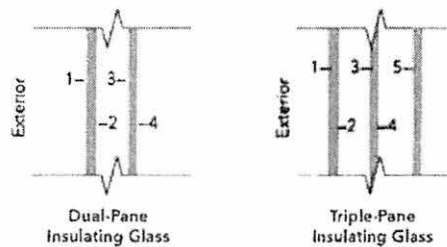

(1) Performance of products with 3/4", 1 3/16" IG or 2.5mm glass is within 10% of those stated for 3mm glass.
 (2) 4mm and 5mm glass construction perform similar to 3mm within 10%.

* Wood products, Pella® Impervia and Pella 350 Series: Side 3, Pella 250 Series and Encompass by Pella™: Side 2
 ** Varies by product



UNIT SECTIONS
Block Frame



FIXED FRAME DIRECT SET

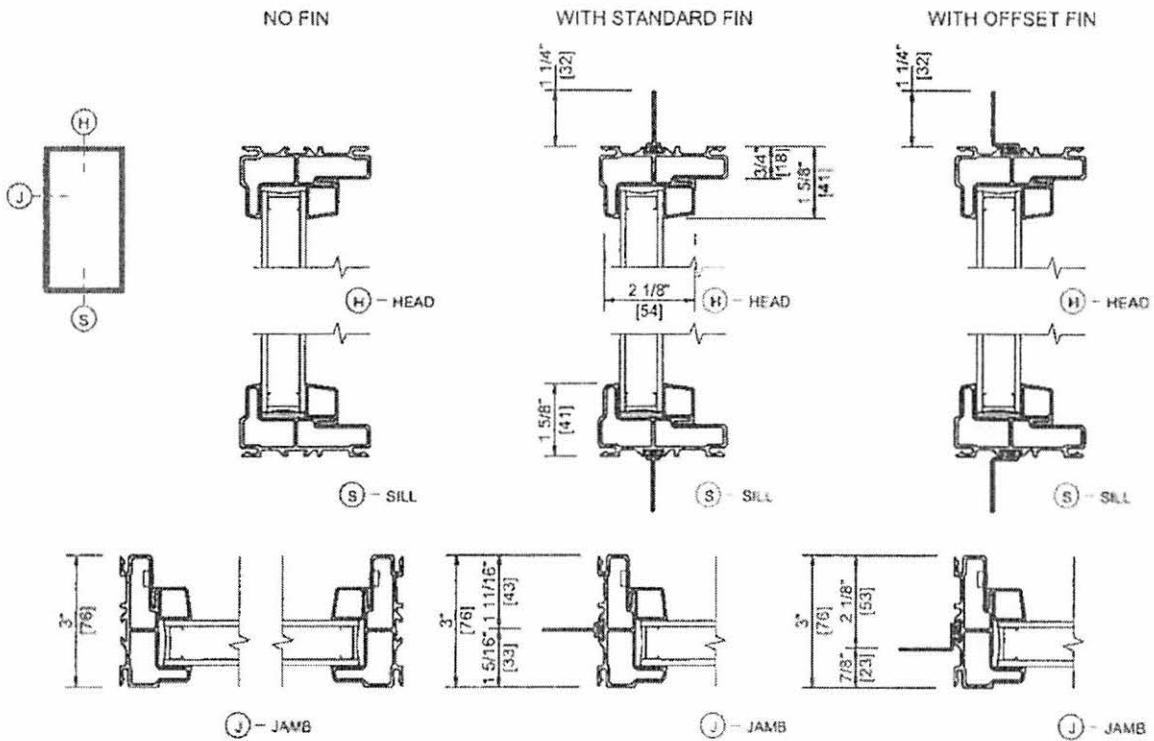

TYPICAL JOINING MULLIONS

COMBINATION

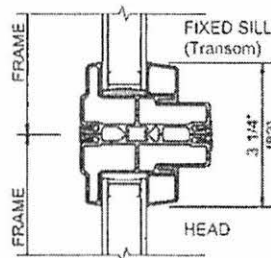

JOINING MULLION
WITH TAPE
(Horizontal or Vertical,
Horizontal Shown)

Scale 3" = 1' 0"

All dimensions are approximate.

Factory-assembled integral mullions have a 3" overall frame width. Combination joining mullions are 3-1/4" frame width.

See the Installation and Performance section at PellaADM.com for mullion applications and structural limitations



UNIT SECTIONS

Large Awning Block Frame and Integral Nailing Fin

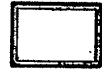

AWNING

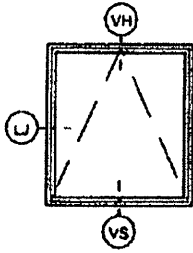

STANDARD
BLOCK FRAME

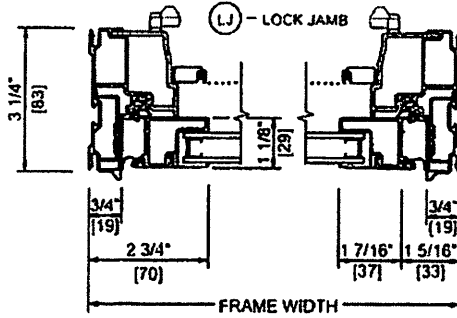
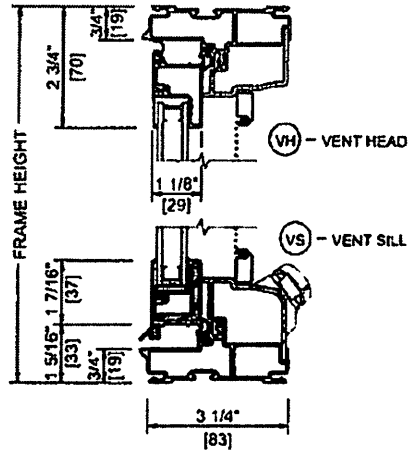

INTEGRAL
NAILING FIN

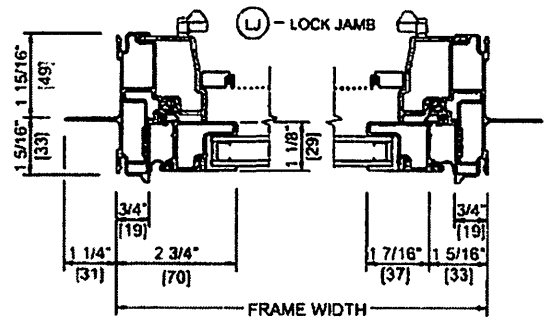
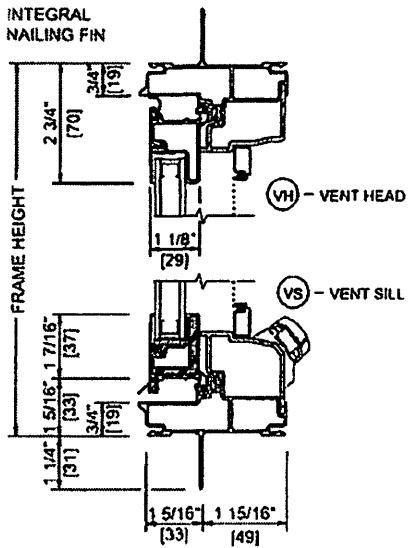

Scale 3" = 1' 0"

All dimensions are approximate.



**PELLA® IMPERVIA®
LIMITED LIFETIME WARRANTY AND
PELLA FIBERGLASS-RESIN
20/10 LIMITED WARRANTY**

Congratulations on choosing Pella Impervia and/or Pella fiberglass-resin window and door products to protect and beautify your home. These superior-quality windows and patio doors have been designed to give you years of comfort.

IMPORTANT NOTICE: Read this entire Pella Limited Warranty and Limitation of Liability ("Limited Warranty") before purchasing or installing this product. Refer to the *Pella Impervia Owner's Manual* for the required care and maintenance of your Pella products (Owner's Manuals available on pella.com). By installing or using this product, you are acknowledging that this Limited Warranty is part of the terms of sale.

LIMITED LIFETIME WARRANTIES FOR PRODUCTS INSTALLED IN OWNER-OCCUPIED SINGLE-FAMILY HOMES EXCLUDE PELLA IMPERVIA'S DURACAST® MATERIAL FOR RECTANGULAR PRODUCTS INSTALLED IN OTHER THAN OWNER-OCCUPIED SINGLE-FAMILY HOMES

This Limited Warranty applies only to Pella Impervia and Pella fiberglass-resin products ("Covered Pella Products"). Pella makes the following exclusive express Limited Warranties for Pella Impervia and Pella fiberglass-resin products installed in owner-occupied single-family homes within the United States and Canada, subject to the stated conditions and limitations.

Nontransferable Limited Lifetime Warranty on Pella Impervia's Duracast Material.

Pella warrants that its Duracast material, which makes up the rectangular frame, sash or panel parts of Pella Impervia window and door products, will be free from cracking, splitting, corroding and warping for as long as you own your home. If Pella is given proper notice of a defect in the Duracast materials of a Pella Impervia rectangular window or door product, Pella shall, at its sole option: 1) repair or replace the defective part(s) or product(s) (with cost of labor included only within two [2] years of the date of sale by Pella or its authorized dealer) or 2) refund the original purchase price. This Limited Lifetime Warranty is provided to the original homeowner and may not be assigned or transferred. The Duracast Limited Lifetime Warranty does not cover the paint finish applied to the Duracast material, which is covered under the transferable ten-year (10-year) warranty on material and workmanship found below. In addition, the Transferable Ten-Year (10-Year) Limited Warranty on materials and workmanship replaces the Limited Lifetime Warranty on Pella's Duracast® material when you transfer ownership of your single-family home or cease to occupy your home.

20/10 LIMITED WARRANTY ON PELLA'S FIBERGLASS-RESIN MATERIAL FOR NONRECTANGULAR PRODUCTS INSTALLED IN OWNER-OCCUPIED SINGLE-FAMILY HOMES, RESIDENTIAL AND COMMERCIAL APPLICATIONS

Pella's Fiberglass-Resin Material (Non-Duracast Material) — Transferable Ten-Year (10-Year) Limited Warranty. Pella warrants that its fiberglass-resin material, which makes up the frame and glass stops of the nonrectangular Special Shapes (i.e., half-circles, triangles, etc.), shall be free of defects in material or workmanship that significantly impair their proper operation and function for ten (10) years from the date of sale by Pella or its authorized dealer. If Pella is given notice of a defect in materials or workmanship of a Pella product occurring within ten (10) years from the date of sale by Pella or its authorized dealer, Pella shall, at its sole option: 1) repair or replace the defective part(s) or product(s) (with cost of labor included only within two [2] years of the date of sale by Pella or its authorized dealer) or 2) refund the original purchase price. This Limited 10-Year Warranty may be transferred.

The following applies to the Pella Impervia[®] Limited Lifetime Warranty and the Pella Fiberglass-Resin 20/10 Limited Warranty:

TRANSFERABLE LIMITED WARRANTIES FOR NONGLASS MATERIALS, WORKMANSHIP AND GLASS FOR DURACAST PRODUCTS INSTALLED IN RESIDENTIAL AND COMMERCIAL APPLICATIONS

Nonglass Materials and Workmanship. Transferable Ten-Year (10-Year) Limited Warranty.

This Transferable Ten-Year (10-Year) Limited Warranty applies to the Duracast material not installed in owner-occupied single-family homes, and automatically replaces the Duracast Material Nontransferable Limited Lifetime Warranty for products installed in owner-occupied single-family homes, upon Buyer's transfer of ownership of the single-family home or at such time that the Buyer ceases to occupy the home within ten (10) years of the date of sale by Pella or its authorized dealer. Pella[®] warrants that all nonglass components of its Covered Pella Products shall be free of manufacturing defects in material or workmanship that significantly impair their proper operation and function for ten (10) years from the date of sale by Pella or its authorized dealer. If Pella is given notice of a defect in materials or workmanship of a Pella Impervia product occurring within ten (10) years from the date of sale by Pella or its authorized dealer, Pella shall, at its sole option: 1) repair or replace the defective part(s) or product(s) (with cost of labor included only within two [2] years of the date of sale by Pella or its authorized dealer) or 2) refund the original purchase price. This Ten-Year (10-Year) Limited Warranty may be transferred.

Nonlaminated Glass. Transferable Twenty-Year (20-Year) Limited Warranty.

Pella warrants that the glass in Pella products shall be free from premature failure or permanent material obstruction of vision due to a failure of the glass seal for twenty (20) years from the date of sale by Pella or its authorized dealer. If Pella is given notice of a glass defect occurring within twenty (20) years of the date of sale by Pella or its authorized dealer, Pella shall, at its sole option: 1) repair or replace the defective glass (with cost of labor included only within two [2] years of the date of sale by Pella or its authorized dealer) or 2) refund the original purchase price.

Exterior Surround Made with AZEK[®] Trim. Transferable Twenty-Five-Year (25-Year) Limited Warranty.

Pella warrants that the exterior surround, made with AZEK Trim, shall be free of rot, corrosion, delaminating or excessive swelling from moisture for twenty-five (25) years from the date of sale by Pella or its authorized dealer. Product must be installed and painted (finished) in accordance with Pella's Installation Instructions. If Pella is given notice of a defect occurring within twenty-five (25) years of the date of sale by Pella or its authorized dealer, Pella shall, at its sole option: 1) repair or replace the defective component(s) (with cost of labor included only within two [2] years of the date of sale by Pella or its authorized dealer) or 2) refund the original purchase price of the defective parts. This warranty does not cover the painted finishes or coating applied to the product by the original purchaser or any third party.

LIMITED WARRANTIES ON FRAMES USED ON BAY AND BOW WINDOWS FOR PELLA IMPERVIA PRODUCTS INSTALLED IN OWNER-OCCUPIED SINGLE FAMILY HOMES, RESIDENTIAL AND COMMERCIAL APPLICATIONS*

Nonglass Components. Transferable Ten-Year (10-Year) Limited Warranty.

Pella warrants that the nonglass components of its Covered Pella Products shall be free of manufacturing defects in material or workmanship or termite damage that significantly impair their proper operation and function for ten (10) years from the date of sale by Pella or its authorized dealer. If Pella is given notice of a defect in materials or workmanship occurring within ten (10) years from the date of sale by Pella or its authorized dealer, Pella shall, at its sole option: 1) repair or replace the defective part(s) or product(s) (with cost of labor included only within two [2] years of the date of sale by Pella or its authorized dealer) or 2) refund the original purchase price. This Limited Warranty on Nonglass Components does not apply to nonpainted hardware finishes.

Interior Factory Finish. Two-Year (2-Year) Limited Warranty.

Pella warrants that all factory-applied interior paint and stain finishes to bay/bow frames by Pella Corporation will be free of any "Finish Defect" for a period of two (2) years from the date of sale by Pella or a Pella-authorized dealer. Pella products with factory-applied interior primer only are excluded from the interior finish Limited Warranty. A Finish Defect includes cracking, peeling, checking, delaminating, blistering, flaking, chalking in excess of a numerical rating of six (when measured in accordance with the standard practice specified in ASTM D659) or fading or change in color in excess of five "E" units (NBS), calculated in accordance with ASTM 2244. If Pella is given notice of such Finish Defect within two (2) years from the date of sale, Pella shall, at its sole option: 1) refinish the product (the finish may not necessarily be the same finish as originally applied to the product), 2) furnish labor to replace or repair any defective finish workmanship (and provide replacement materials if Pella determines such materials are necessary to make the repairs) or 3) refund the original purchase price of the defective item in question. This Finish Warranty is provided to the original Buyer and may not be assigned or transferred, although the limitations of liability set forth herein apply to all sales and persons.

*Bay and bow windows for Pella Impervia made with wood frame.

CONDITIONS APPLICABLE TO ALL LIMITED WARRANTIES

Limitation of Warranty.

FAILURE TO COMPLY WITH PELLA® INSTALLATION AND MAINTENANCE INSTRUCTIONS VOIDS ALL WARRANTIES UNLESS IT IS CLEARLY ESTABLISHED BY THE BUYER OR USER OF THE PRODUCT THAT THE DEFECT OR FAILURE IS UNRELATED TO SUCH NONCOMPLIANCE. This Limited Warranty does not extend to the use of Covered Pella Products under abnormal conditions, conditions that exceed the stated performance parameters of the product as provided on the product labeling and in the Pella Architectural Design Manual, or under conditions not reasonably foreseeable to, or beyond the control of, Pella. Buyer and User assume all risk of any such use. This Limited Warranty is the exclusive warranty for the Covered Pella Products. **NEITHER PELLA NOR SELLER MAKE ANY OTHER WARRANTIES, EXPRESS OR IMPLIED, INCLUDING ANY IMPLIED WARRANTIES OF MERCHANTABILITY, FITNESS FOR A PARTICULAR PURPOSE OR OTHERWISE.** This disclaimer of implied warranties may be limited or ineffective if you are a consumer, as that term is defined by the Magnuson Moss Act, 15 U.S.C. § 2301, in which case the duration of any implied warranties shall be two (2) years from the date of sale by Pella or its authorized dealer. Some states do not allow limitations on how long an implied warranty lasts for consumers, so the above limitation may not apply to you, in which event the manner of presenting any claim thereon shall be the same as provided in the express warranties stated herein. This Limited Warranty gives you specific legal rights, and you may have additional rights, which vary from state to state.

Allocation of Risks of Pella Product Performance.

Because all construction must anticipate some water infiltration, it is important that the wall system be designed and constructed to properly manage moisture. Pella Corporation is not responsible for claims or damages caused by anticipated or unanticipated water infiltration; deficiencies in building design, construction and maintenance; failure to install Pella products in accordance with Pella Installation Instructions; or the use of Pella products in barrier wall systems, which do not allow for proper management of moisture within the wall system (see the following). The determination of the suitability of all building components, including the use of Pella products, as well as the design and installation of flashing and sealing systems, is the responsibility of Buyer or User, architect, contractor, installer or other construction professional, and is not the responsibility of Pella. All risks related to building design and construction, or the maintenance, installation and use of Pella products, shall be assumed by Buyer and/or User.

IMPORTANT NOTICE: Pella products should not be used in barrier wall systems, which do not allow for proper management of moisture within the wall systems, such as Exterior Insulation Finish Systems (EIFS) (also known as synthetic stucco) or similar systems. Except in the states of California, New Mexico, Arizona, Nevada, Utah and Colorado, Pella makes no warranty of any kind on and assumes no responsibility for Pella windows and doors installed in barrier wall systems. In the states listed above, the installation of Pella products in EIFS or similar barrier systems must be in accordance with Pella's instructions for that type of construction.

Limitation of Liability.

This Limited Warranty sets forth the maximum liability for our products. **IN NO EVENT (INCLUDING WHERE THIS LIMITED WARRANTY IS DEEMED NOT TO APPLY TO THE SALE OR PRODUCT IN QUESTION) SHALL PELLA OR SELLER BE LIABLE FOR ANY INCIDENTAL, CONSEQUENTIAL OR SPECIAL DAMAGES RESULTING FROM THE SALE, INSTALLATION OR USE OF ANY PELLA® PRODUCTS.** Some states do not allow the exclusion or limitation of incidental or consequential damages for consumers, so the above limitation or exclusion may not apply to you.

Limitation of Remedy.

THE EXCLUSIVE REMEDY OF THE BUYER OR USER, AND THE SOLE LIABILITY OF PELLA AND SELLER, FOR ANY AND ALL CLAIMS, LOSSES, INJURIES OR DAMAGES (INCLUDING CLAIMS BASED ON BREACH OF WARRANTY, CONTRACT, NEGLIGENCE, TORT, STRICT LIABILITY OR OTHERWISE) RESULTING FROM THE SALE, INSTALLATION OR USE OF THESE PRODUCTS, SHALL BE, AT THE OPTION OF PELLA, THE REPAIR OR REPLACEMENT OF THE PRODUCT OR THE RETURN OF THE ORIGINAL PURCHASE PRICE OF THE PRODUCT, AS PROVIDED HEREIN. IN NO EVENT SHALL THE LIABILITY OF PELLA OR SELLER EXCEED THE PRICE PAID FOR THE PRODUCT. Replacement products shall be a reasonably similar current product and may not exactly match the original. Even where Pella chooses to repair or replace product within two (2) years of the date of sale, the costs covered by this warranty do not include any labor or material costs associated with finishing space surrounding or adjacent to the repaired or replaced product, including furnishing any trim or other carpentry work. Replacement product provided pursuant to this Limited Warranty shall be subject to the applicable Pella product Limited Warranty only for the remainder of the original warranty period on the product being replaced. If Pella or Seller provides any of the remedies identified in the Limited Warranties above (i.e., repair, replacement of product or refund of the purchase price), then Buyer and/or User agrees that this limitation of remedy shall not have failed of its essential purpose.

DISCLAIMER — WHAT THIS LIMITED WARRANTY DOES NOT COVER

Pella is not responsible for or makes no warranty as to:

1) Product failure, loss or damage due to:

- Normal wear and tear.
- Improper storage, handling, installation, finishing, use, modification or maintenance.
- Mechanical abrasion to finishes.
- Non-factory-applied finishes, applied sealants or caulking. Finishes applied by your local dealer/contractor are not covered by this warranty.
- Damage caused by failing to finish your bay or bow frames in a timely manner to protect them from UV rays and the elements.
- Nonfactory finishing, repairs or modifications performed by anyone other than Seller (or one of its subcontractors).
- Finishes of non-Pella® products.
- The buyer's choice of finish, or whether the chosen finish on bay or bow frames is a match to other or existing finishes.
- Structural settlement, movement or vibration.
- Product or finishes exposed to excessive localized heat, high-moisture environments (including pools, hot tubs and greenhouses) or water leakage.
- Finish failure or any other losses arising from defects in the existing structure.
- Interior prime finish on bay or bow frames.
- Normal wear, fading or discoloration of finish from product usage, age or exposure to direct sunlight.
- Acts of God.
- Acid rain or other corrosive elements.
- Installation of anything other than standard factory-installed glass in Duracast® frames.
- Accidents, including accidental glass breakage.
- Application of after-market window films to glass surfaces.
- Damage caused by inappropriate finishes, solvents, brickwash or cleaning chemicals.
- Glass breakage, not the fault of Pella, that results in seal failure.
- Damage to glass as a result of improper use or application.
- Damage caused by high in-home humidity (condensation, frost and mold).
- Accident; misuse; abuse; alterations; improper handling operation or cleaning.
- Products subjected to conditions outside product design limitations.
- Improperly installed security systems.
- Products with modifications that are not approved by Pella Corporation.
- Hardware finishes.
- Ripping, tearing or other damage not the fault of Pella to window screens associated with wear and tear through product use.
- Insects, including grasshoppers (with the exception of coverage for termites on bay or bow frames).
- Finishing or modifying the structure containing repaired or replaced product.
- The purchase, damage, repair or replacement of non-Pella products.
- Products that have not been paid for in full.

2) Minor imperfections in the product:

- Minor imperfections in glass that do not affect the product's structural integrity or significantly obscure vision.
- Minor variations in glass color.
- Variations in wood grain, color, texture or natural characteristics on bay or bow frames.

3) Installation inconsistent with Pella Installation Instructions:

- Damage resulting in whole or in part from installation inconsistent with Pella's Installation Instructions.
- Altered or reinstalled products.
- Products used in nonvertical glazing applications.
- Combinations not built by Pella or not built in accordance with Pella's recommendations for mulling and combining Pella products.

WDMA Hallmark Certification.

Pella® products labeled with the Window & Door Manufacturers Association (WDMA) Hallmark Certification are tested in accordance with applicable WDMA performance standards, which require products to be tested for air infiltration, water infiltration and structural performance. The WDMA certification standards measure the performance of a single sample of the product at the time of manufacture. Performance of Pella products, as measured by the WDMA standards, will change over time depending upon the conditions of use. For details on Hallmark Certification, go to WDMA.com. All Hallmark Certification performance ratings apply to individual products only. Pella makes no claims as to the overall performance of mulled and/or product combinations.

NFRC Standards.

Pella® products labeled with the National Fenestration Rating Council (NFRC) Energy Performance label are tested in accordance with NFRC standards. NFRC ratings are based on a combination of computer simulations and physical testing of product samples. For details on NFRC Energy Performance ratings, go to NFRC.org.

Argon.

For Pella products labeled as having Low-E insulating glass with argon, Pella injects argon at the time of manufacture. No warranty is made as to the amount or percentage of argon present in the insulating glass. It is known that argon within insulating glass dissipates over time. The manner of use and conditions of installation of the product will affect the rate of dissipation of argon out of the insulating glass. Pella makes no warranty regarding the rate of dissipation of argon or the amount of argon remaining in the window at any time after manufacture.

Prompt Notice of Claim.

Within the warranty period, Buyer or User shall promptly notify Pella, and in no case more than one (1) year after any defect or other basis of a claim covered by this Limited Warranty is discovered or should have been discovered. Any claims otherwise covered by the foregoing warranties, but for which Pella did not receive notice within one (1) year from the time the problem first became known, shall be barred.

Limited Warranty Claim Procedure.

Claims under these Limited Warranties may be made in writing to **Pella Corporation, Customer Service Department, 102 Main Street, Pella, IA 50219**, by calling for service at 800-374-4758 or by going to <http://warranty.pellaimpervia.com>. Claims to Pella should include the following information:

1. Claimant's name, address and phone number and the installation address (if different);
2. A description of the product, purchase price, date and location of purchase, and copies of invoices;
3. The Pella serial number located on the insulating glass spacer or the unit identification number located on the lower left-hand corner of the glass (as seen from the inside);
4. A description of the product concerns (photos may be included); and
5. A brief summary of attempts made to address the concerns.

Pella may charge a fee for on-site product inspections.

No Statement of Useful Life.

This Limited Warranty is not a statement of the useful life of any Pella® products.

Entire Agreement.

With the exception of a written statement signed by an authorized Pella representative, this Limited Warranty and all the terms contained herein constitutes the entire agreement between Pella/Seller and Buyer/User. This Limited Warranty, including all Limitations of Liability contained herein, is made a part of any such written agreement, unless expressly excluded therein. By purchasing or using the product covered by this Limited Warranty, Buyer/User agrees that they are not relying on any oral statements made by anyone that are in any way contrary to this Limited Warranty.

No Amendment Except in Writing.

Pella and Seller offer this product, and Buyer and User accept it, subject to the foregoing Limited Warranty, which may be modified only by written agreement signed by a duly authorized representative of Pella.

For the most up-to-date warranty information, see the complete warranties for all Pella products on pella.com.

Read the *Pella Impervia Owner's Manual* for the required care and maintenance of your Pella products. All Pella Owner's Manuals are available on pella.com.



February 22, 2019

City of Sheboygan
828 Center Ave.
Suite 205
Sheboygan, WI 53081

Attn: Bernie Rammer

Bernie,

This letter confirms that our installers for this project are employees of Pella Windows and Doors of Wisconsin and have over three years' experience in the installation of commercial grade windows. Listed below are three recent projects that we have completed:

Country Inn & Suites, Appleton WI
Bohemian Park Apartments, Green Bay WI
Menominee County Courthouse, Menominee MI

If you have any questions, please call.

Sincerely,

Rob Coleman
Commercial Sales

Pella Windows & Doors of Wisconsin, a division of VerHalen, Inc.
500 Pilgrim Way
Green Bay, WI 54304
1-800-242-1008
920-435-3791
FAX 920-435-0377

III

Res. No. _____ - 18 - 19. By Alderpersons Wolf and Sorenson.
March 18, 2019.

A RESOLUTION authorizing the appropriate City officials to execute the Amendment to Operating Agreement Between City of Sheboygan and Power Pubs, LLC.

RESOLVED: That the Mayor and City Clerk are hereby authorized to execute the Amendment to Operating Agreement Between City of Sheboygan and Power Pubs, LLC, a copy of which is attached hereto and incorporated herein.

Public Works

I HEREBY CERTIFY that the foregoing Resolution was duly passed by the Common Council of the City of Sheboygan, Wisconsin, on the _____ day of _____, 20____.

Dated _____ 20____. _____, City Clerk

Approved _____ 20____. _____, Mayor

AMENDMENT TO
OPERATING AGREEMENT BETWEEN
CITY OF SHEBOYGAN
AND
POWER PUBS, LLC

This Amendment amends the Operating Agreement between the City of Sheboygan ("City") and Power Pubs, LLC, a Wisconsin Limited Liability Company ("Vendor") ("Agreement"). The Agreement was originally executed on September 3, 2018. Except as specified herein, the Agreement remains unchanged and in full force and effect.

The parties hereto are the parties to the Agreement and, for good and valuable consideration, mutually agree to the following amendments to the Agreement:

1. Subsection 3(B) of the Agreement shall be amended to state, in full:
"Additional offerings. Vendor shall provide and offer for sale a light food menu. This menu shall include pretzels and snacks, and may also, but is not obligated to, include authentic bratwurst and other meat and sausage products, with a preference for those made in Sheboygan. If Vendor obtains and maintains the appropriate alcohol permits, Vendor may serve wine at the Premises."
2. Subsection 3(S) of the Agreement shall be amended to state, in full:
"Payment. For the use of the Premises and the right to provide the services set forth therein, in addition to the utility costs imposed under Subsection G and the security deposit under subsection R above, Vendor agrees to pay the City 12.5% of its Net Revenues (defined as Gross Revenues minus Sales Tax minus Actual Credit Card Processing Fee minus Tips) (the "City Fee"). For the avoidance of doubt, Gross Revenue shall not include any Glass Deposit that Vendor receives, and no deduction from Gross Revenue shall be made for the return of any Glass Deposit. In 2019, Vendor shall remit the City Fee no later than December 1, 2019. Vendor may, but is not required to, make voluntary payments toward the City Fee prior to December 1, 2019. For all years after 2019, Vendor shall make estimated payments in fourths due no later than July 1, August 15, and October 1 of each year, with estimated payments based on Net Revenue from the prior year. A final payment based on actual net revenue, and taking into account the estimated payments made, shall be made no later than December 1 of each year."
3. Paragraph 23 contains a definition of "Sales Reports." That definition shall be amended to state, in full: "Sales Reports shall contain: (1) quantities purchased, by SKU; (2) revenues generated, by SKU; (3) total gross revenue; (4) sales taxes; (5) credit card processing fee; (6) total Net Revenue; and (7) the City Fee."

**AMENDMENT TO
OPERATING AGREEMENT BETWEEN
CITY OF SHEBOYGAN
AND
POWER PUBS, LLC**

This Amendment amends the Operating Agreement between the City of Sheboygan ("City") and Power Pubs, LLC, a Wisconsin Limited Liability Company ("Vendor") ("Agreement"). The Agreement was originally executed on September 3, 2018. Except as specified herein, the Agreement remains unchanged and in full force and effect.

The parties hereto are the parties to the Agreement and, for good and valuable consideration, mutually agree to the following amendments to the Agreement:

1. Subsection 3(B) of the Agreement shall be amended to state, in full:
"Additional offerings. Vendor shall provide and offer for sale a light food menu. This menu shall include pretzels and snacks, and may also, but is not obligated to, include authentic bratwurst and other meat and sausage products, with a preference for those made in Sheboygan. If Vendor obtains and maintains the appropriate alcohol permits, Vendor may serve wine at the Premises."
2. Subsection 3(S) of the Agreement shall be amended to state, in full:
"Payment. For the use of the Premises and the right to provide the services set forth therein, in addition to the utility costs imposed under Subsection G and the security deposit under subsection R above, Vendor agrees to pay the City 12.5% of its Net Revenues (defined as Gross Revenues minus Sales Tax minus Actual Credit Card Processing Fee minus Tips) (the "City Fee"). For the avoidance of doubt, Gross Revenue shall not include any Glass Deposit that Vendor receives, and no deduction from Gross Revenue shall be made for the return of any Glass Deposit. In 2019, Vendor shall remit the City Fee no later than December 1, 2019. Vendor may, but is not required to, make voluntary payments toward the City Fee prior to December 1, 2019. For all years after 2019, Vendor shall make estimated payments in fourths due no later than July 1, August 15, and October 1 of each year, with estimated payments based on Net Revenue from the prior year. A final payment based on actual net revenue, and taking into account the estimated payments made, shall be made no later than December 1 of each year."
3. Paragraph 23 contains a definition of "Sales Reports." That definition shall be amended to state, in full: "Sales Reports shall contain: (1) quantities purchased, by SKU; (2) revenues generated, by SKU; (3) total gross revenue; (4) sales taxes; (5) credit card processing fee; (6) total Net Revenue; and (7) the City Fee."

III

Res. No. _____ - 18 - 19. By Alderpersons Wolf and Sorenson.
March 18, 2019

A RESOLUTION expressing the sense of the Council that transitioning to an Automated Garbage and Recycling Collection Program is in the best interest of the City.

WHEREAS, the City of Sheboygan's Department of Public Works ("Department") currently operates its residential garbage and recycling program by manually collecting garbage and recycling materials in bags; and

WHEREAS, the trucks used for the City's residential garbage and recycling program are nearing the end of their life cycle; and

WHEREAS, in anticipation of the need to replace the trucks, the City engaged Foth Infrastructure and Environmental LLC ("Foth") in order to analyze the various options for residential garbage and recycling collection as they currently exist and to understand their application to Sheboygan; and

WHEREAS, based on the Foth analysis, and the Department's knowledge and experience with residential garbage and recycling collection, the Department recommends that the City's residential garbage and recycling program convert to an automated garbage and recycling collection program that is operated by the City ("Automated Garbage and Recycling Collection Program"); and

WHEREAS, the Department believes that the Automated Garbage and Recycling Collection Program will improve workers' health and safety, result in cleaner collection, and lead to increased recycling; and

WHEREAS, the Council recognizes that there are numerous steps that will need to be taken in order to bring the Automated Garbage and Recycling Collection Program online, including the purchase and delivery of new trucks and the necessary carts, changes to City ordinances related to garbage and recycling, and public outreach; and

WHEREAS, given the long lead time, the Department proposes to order the new garbage and recycling trucks, which the Department expects will cost approximately \$2 million, shortly after receiving Council approval; and

WHEREAS, the Department anticipates working with the Council and the City Attorney during the spring, summer, and fall of 2019 to prepare any revisions to the municipal code made necessary by the Automated Garbage and Recycling Collection Program; and

WHEREAS, the Department anticipates working extensively with the community as part of a coordinated outreach and education program; and

WHEREAS, in early 2020, the Department anticipates returning to the Council with a request to approve the purchase of the necessary garbage and

Public Works

recycling bins for the Automated Garbage and Recycling Collection Program, which the Department anticipates will cost approximately \$2 million; and

WHEREAS, given the current lead time for garbage and recycling trucks and carts, the need for public outreach, and the need for training on the new garbage and recycling trucks, the Department is targeting beginning the Automated Garbage and Recycling Collection Program in Spring 2020; and

WHEREAS, the Council notes that the Department has proposed paying for some of the operational costs related to the Automated Recycling Program through the imposition of a Recycling Fee; and

WHEREAS, it is the Council's understanding that such a Recycling Fee would not trigger a negative adjustment to the City's levy under Wis. Stat. § 66.0602(2m).

NOW, THEREFORE, BE IT RESOLVED: That it is the sense of the Council that transitioning the City's current manual garbage and recycling program to an Automated Garbage and Recycling Collection Program is in the best interest of the City.

I HEREBY CERTIFY that the foregoing Resolution was duly passed by the Common Council of the City of Sheboygan, Wisconsin, on the _____ day of _____, 20____.

Dated _____ 20____. _____, City Clerk

Approved _____ 20____. _____, Mayor

III

Res. No. _____ - 18 - 19. By Alderpersons Wolf and Sorenson.
March 18, 2019.

A RESOLUTION authorizing the Department of Public Works to purchase seven New Way/Autocar automated garbage and recycling collection trucks.

WHEREAS, the trucks that are currently used for the City's residential garbage and recycling program are nearing the end of their life cycle; and

WHEREAS, the City of Sheboygan's Department of Public Works ("Department") believes now is an appropriate opportunity to automate the City's residential garbage and recycling program ("Automated Garbage and Recycling Collection Program"); and

WHEREAS, the Common Council of the City of Sheboygan agrees with this recommendation; and

WHEREAS, the Department has evaluated several manufacturers and brands of trucks for the Automated Garbage and Recycling Collection Program, and believes that the New Way/Autocar configuration is the most advantageous to the City; and

WHEREAS, the New Way/Autocar trucks are built in Scranton, Iowa; and

WHEREAS, state law and the City's Procurement Policy allows the City to join with other purchasing associations in cooperative purchasing plans when the best interest of the City would be served; and

WHEREAS, the New Way/Autocar trucks are available under the nationwide Sourcewell (formerly National Joint Powers Alliance) cooperative purchasing plan; and

WHEREAS, the City has obtained a quote for seven New Way/Autocar trucks with the specifications requested by the City, a copy of which is attached; and

WHEREAS, according to the quote, the cost will be Two Million Two Thousand Four Hundred Ninety-eight and 30/100 Dollars (\$2,002,498.30) for the seven trucks (or \$286,071.19 per truck); and

WHEREAS, having reviewed the relevant documents, the Department believes, and the Council agrees that this is the best procurement method for this purchase.

NOW, THEREFORE, BE IT RESOLVED: That the Purchasing Agent is authorized to issue a Purchase Order to Envirotech Equipment for the purchase of seven (7) New Way/Autocar automated garbage and recycling collection trucks.

BE IT FURTHER RESOLVED: That the Council understands that this Purchase Order will be subject to the terms and conditions set forth in Sourcewell

Public Works

Contract #112014-THC, a copy of which is available at *sourcewell-mn.gov*.

BE IT FURTHER RESOLVED: That the appropriate City Officials are hereby authorized to draw funds in the amount of \$2,002,498.33 (\$286,071.19 per truck) from the Motor Vehicle Equipment Heavy Trucks Fund (Account No. 70136100-641400).

I HEREBY CERTIFY that the foregoing Resolution was duly passed by the Common Council of the City of Sheboygan, Wisconsin, on the _____ day of _____, 20____.

Dated _____ 20____. _____, City Clerk

Approved _____ 20____. _____, Mayor



Driving The Difference.

Sourcewell Contract # 112014-NWY
Quote for: City of Sheboygan
2026 New Jersey Ave
Sheboygan, WI 53081
Dealer: Envirotech Equipment
Date: 2/19/2019
Sourcewell Member#: 66047

Dealer must receive copy of PO

Table with 4 columns: Quantity, Part No., Description, Sourcewell Price. Lists various truck components and their prices, including a sub-total for the NewWay Body and a total price for 7 complete units.

CITY MEMBER # MUST BE ON P.O.



A Product of Scranton Mfg. Co., Inc. - 101 State Street - Scranton, IA 51462
800 831 1858 • 712 652 3399 - www.newwaytrucks.com

III

Res. No. _____ - 18 - 19. By Alderpersons Wolf and Sorenson.
March 18, 2019.

A RESOLUTION authorizing the appropriate City Officials to enter into a contract with Sun Graphics Media for the creation of materials for public education and outreach related to the Automated Garbage and Recycling Program.

WHEREAS, based on a variety of factors, the City of Sheboygan's Department of Public Works ("Department") has recommended that the City automate its residential garbage and recycling program ("Automated Garbage and Recycling Program"); and

WHEREAS, the Common Council of the City of Sheboygan agrees with this recommendation; and

WHEREAS, one important component to the success of the Automated Garbage and Recycling Program is public education and outreach prior to when the Automated Garbage and Recycling Program begins; and

WHEREAS, Sun Graphics Media is willing and able to provide the services required to create an extensive public education and outreach campaign for the Automated Garbage and Recycling Program, including a website, social media management, marketing support, design services, and video production.

NOW, THEREFORE, BE IT RESOLVED: That the appropriate City Officials are authorized to enter into the attached contract with Sun Graphics Media for services related to public education and outreach regarding the Automated Garbage and Recycling Program with a total cost of \$42,250.00.

BE IT FURTHER RESOLVED: That the appropriate City Officials are hereby authorized to draw funds in the amount of \$42,250.00 from the Motor Vehicle Equipment Heavy Trucks Account No. 70136100-641400.

I HEREBY CERTIFY that the foregoing Resolution was duly passed by the Common Council of the City of Sheboygan, Wisconsin, on the _____ day of _____, 20____.

Dated _____ 20____. _____, City Clerk

Approved _____ 20____. _____, Mayor

Public Works

**AGREEMENT
BETWEEN THE CITY OF SHEBOYGAN, WISCONSIN AND
SUN GRAPHICS MEDIA**

**FOR SERVICES RELATED TO PUBLIC OUTREACH AND EDUCATION REGARDING
AUTOMATED GARBAGE AND RECYCLING IN THE CITY OF SHEBOYGAN**

This Agreement (“Agreement”) is made and entered into effective this ____ day of _____, _____ (the “Effective Date”), by and between the City of Sheboygan (the “City”), a municipal corporation, and Sun Graphics Media (“Designer”).

WITNESSETH:

WHEREAS, the City is moving forward on transitioning from its current method of handling residential garbage and recycling, which involves manually lifting bags into trucks, to an automated system (“Automated Garbage and Recycling Program”); and

WHEREAS, the success of the Automated Garbage and Recycling Program requires a public outreach and education program; and

WHEREAS, Sun Graphics Media is capable of providing the City with the necessary deliverables for the public outreach and education program, and desires to provide the City with those deliverables pursuant to the terms of this Agreement.

NOW, THEREFORE, in consideration of the mutual covenants herein contained, the parties hereto agree as follows:

Article 1. Definitions

1. “Agreement” means the entire content of this document, and any other supplement, exhibit, or additional schedule as may be attached to this document and incorporated herein by reference.
2. “Client Content” means all materials, information, photography, writings, and other creative content provided by the City for use in the preparation of and/or incorporation in the Deliverables.
3. “Copyrights” means the property rights in original works of authorship, expressed in a tangible medium of expression, as defined and enforced under U.S. Copyright Law.
4. “Deliverables” means the services and work product, as mutually agreed upon by the City and Designer, to be delivered by Designer to the City.
5. “Designer Tools” means all design tools developed and/or utilized by Designer in performing the Services, including, without limitation, pre-existing and newly developed software including source code, Web authoring tools, type fonts, and application tools, together with any other software or other inventions (whether or not patentable), and general

non-copyrightable concepts such as website design, architecture, layout, navigational and functional elements.

6. "Final Art" means all creative content developed or created by Designer, or commissioned by Designer, exclusively for the Project and incorporated into and delivered as part of the Final Deliverables, including, but not limited to, any and all visual designs, visual elements, graphic design, illustration, photography, animation, sounds, typographic treatments and text, modifications to Client Content, and Designer's selection, arrangement, and coordination of such elements together with Client Content and/or Third Party Materials, as approved and accepted by the City.
7. "Final Deliverables" means the final versions of Deliverables provided by Designer, as approved and accepted by the City.
8. "Preliminary Works" means all artwork including, but not limited to, concepts, sketches, visual presentations, or other alternate or preliminary designs and documents, developed by Designer, which may or may not be shown and or delivered to the City for consideration.
9. "Project" means the scope and purpose of the City's identified usage of the work product.
10. "Services" (or "Designer's Services") means all services and work product to be provided to the City by Designer as described and otherwise further defined in the Deliverables.
11. "Third Party Materials" means proprietary third party materials which are incorporated into the Final Deliverables, including, but not limited to, stock photography or stock illustrations.
12. "Trademarks" means trade names, words, symbols, designs, logos, or other devices or designs used to designate the origin or source of goods or services.

Article 2. Designer's Responsibilities

Designer shall provide the following Services to the City related to the Automated Garbage and Recycling Program:

- **Brand Strategy Development:** completion of all services necessary to develop a cohesive brand for the Automated Garbage and Recycling Program
- **Web Development:** completion of all services related to the development of a professional website promoting and explaining the Automated Garbage and Recycling Program
- **Social Media Management:** completion of all services related to the social media outreach for the Automated Garbage and Recycling Program, including any necessary initial review and analysis, development of appropriate personas for social content, creation of a social media plan, preparation of one post per week for fifty two weeks and four videos on multiple social media platforms (including, but not limited to, Facebook, Twitter, and NextDoor), analysis of the impact of the social media outreach, and all necessary adjustments to the social media plan in order to maximize the impact of the social media campaign regarding the Automated Garbage and Recycling Program.
- **Video Production:** completion of all services related to the creation of 12 professional quality videos regarding the Automated Garbage and Recycling Program (in addition to the videos referenced under Social Media Management)
- **General Creative Services:** up to 120 hours of staff time (in addition to the staff time necessary to accomplish the other items provided in this Article) to be spent in development of other print and digital resources in support of the Automated Garbage and Recycling

Program. (In the event that fewer than 110 hours of staff time are used, Designer shall refund the City for unused hours at a rate of \$54.16 per hour.)

Designer represents and warrants:

- All Final Deliverables shall be the original work of Designer.
- To the best of Designer's knowledge, no Final Deliverable or component part of a Final Deliverable shall infringe upon the rights of any party, and the use of such Final Deliverable or component part of a Final Deliverable does not violate the rights of any party.

Article 3. City's Responsibilities

The City is responsible for performing the following in a reasonable and timely manner:

- Coordination of any decision-making with parties other than the Designer
- Provision of Client Content in a form suitable for reproduction or incorporation into the Deliverables without further preparation
- Review of Deliverables within a reasonable amount of time of receipt from Designer. If a Deliverable is not acceptable, the City will inform Designer—in writing—of the nature of the City's objection.
- Final proofreading of the Deliverables prior to final acceptance

Article 4. Standard of Care

Designer shall be responsible for completion of the Services in a manner consistent with that degree of care and skill ordinarily exercised by members of the same profession currently practicing under similar circumstances ("Standard of Care"). The City's designated project manager—David Biebel—shall be the sole judge of the adequacy of Designer's work in meeting the Standard of Care; however, the City shall not unreasonably withhold its approval as to the adequacy of Designer's performance. Upon notice to Designer and by mutual agreement between the parties, Designer will, without additional compensation, correct or replace any and all Services not meeting the Standard of Care.

Article 5. The Parties' Project Managers

Designer designates Justin Webb as its designated project manager with primary responsibility for the performance of this Agreement. In the event of the death, disability, removal, or resignation of the person designated as the Designer's designated project manager, the City—through its designated project manager—may accept another person as the designated project manager or terminate this Agreement. Designer shall provide the City with notice within seven (7) days in the event its designated project manager dies, becomes disabled, is removed, or resigns.

The City designates David Biebel as its designated project manager for purposes of this Agreement.

Article 6. Compensation

The City shall pay Designer—for all fees and expenses related to the Services—an amount not to exceed Forty Two Thousand Two Hundred Fifty Dollars (\$42,250.00) (the "Total Project Cost").

Payment shall be made as follows:

- Twenty One Thousand Two Hundred Fifty Dollars (\$21,250) within thirty (30) days of the effective date of this Agreement (the “Down Payment”).
- Ten Thousand Six Hundred Twenty Five Dollars (\$10,625) within sixty (60) days of the effective date of this Agreement (the “Second Payment”).
- Ten Thousand Six Hundred Twenty Five Dollars (\$10,625) within one hundred twenty (120) days of the effective date of this Agreement (the “Third Payment”).

If the Down Payment is received by Designer on or before April 15, 2019, the Total Project Cost shall be reduced to Thirty Nine Thousand Five Hundred Dollars (\$39,500.00), which shall result in a reduction of the Third Payment to Seven Thousand Eight Hundred Seventy Five Dollars (\$7,875).

Additional services not set forth in this Agreement, or changes in the Services must be authorized in writing by the City or its designated project manager prior to such work being performed or expenses incurred. Any written authorization shall include a not-to-exceed amount. The City shall have no obligation to make payment for any unauthorized work or expenses.

In the event that additional services are appropriately authorized, additional services will be charged to the City at no more than an hourly rate of Eighty Dollars (\$80) per hour. Designer shall provide invoices to the City monthly. Invoices shall be sent to:

David Biebel
City of Sheboygan
Department of Public Works
Municipal Service Building
2026 New Jersey Ave.
Sheboygan, Wisconsin 53081

The City shall make payment within forty-five days of receipt of an Invoice.

Article 7. Appropriation of Funds

Notwithstanding any other provision of this Agreement, if funds for the continued fulfillment of this Agreement by the City are at any time not forthcoming or are insufficient, through failure of any entity, including the City itself, to appropriate funds or otherwise, then the City shall have the right to terminate this Agreement without penalty. The City agrees that it will make its best effort to obtain sufficient funds for the Agreement to meet its obligations hereunder in full.

Article 8. Schedule

Services under this Agreement shall commence promptly upon the full execution of this Agreement by the Parties and shall continue in an orderly fashion until their completion.

Designer shall complete all Services within one (1) year of the Effective Date of this Agreement, or within such extra time as may have been allowed by a mutually agreed extension. Designer’s services are completed upon receipt of the Final Deliverables.

The Parties agree that no charges or claims for damages shall be made by Designer for any delays or hindrances, from any cause whatsoever, during the progress of any portion of the services specified in the Agreement. Such delays or hindrances, if any, may be compensated for by an extension of time for a reasonable period as may be mutually agreed upon between the Parties, it being understood however, that permitting Designer to proceed to complete any service, or any part of the services / project, after the date to which the time of completion may have been extended shall in no way operate as a waiver on the part of the City of any of its rights herein.

Article 9. Confidentiality and Document Retention

Both parties understand that the City is bound by the Wisconsin Public Records Law and, as such, this contract is subject to that law.

Designer acknowledges that it is obligated to assist the City in retaining and producing records that are subject to Wisconsin Public Records Law, and that the failure to do so shall constitute a material breach of the contract, and that Designer must defend and hold the City harmless from liability under that law. Except as otherwise authorized, those records shall be maintained for a period of seven (7) years after receipt of final payment under the Agreement.

To the extent permitted by law, any confidential or proprietary technical and business information received by one Party from the other Party shall be kept in confidence. This shall not in any way prevent the receiving Party from complying with a Public Records Request or an order of any court or other governmental authority.

Article 10. Termination

The City may terminate or suspend performance of this Agreement at the City's prerogative at any time upon written notice to Designer. Designer shall terminate or suspend performance of the Services on a schedule acceptable to the City. If the performance is restarted, an equitable adjustment shall be made to the schedule of services.

In the event Designer breaches this Agreement, including any covenant, agreement, commitment, or condition contained in this Agreement, the City shall have the right—in addition to all other rights and remedies which it may have at law or in equity—to terminate the Agreement upon written notice. Designer shall have ten (10) calendar days from the receipt of the termination notice to cure or to submit a plan for cure acceptable to the City. In the event that the City terminates this Agreement due to a breach of this Agreement, and enters into a subsequent agreement with another party to complete the Services, and such expense plus any expenditure made under this Agreement exceeds the sum which would have been payable under the Agreement, Designer shall be liable and shall pay to the City the amount of said excess.

For purposes of Ownership of Documents and Intellectual Property, in the event the City terminates performance of this Agreement, that termination shall constitute “completion of the Services” and shall result in the assignment and transfer of all rights, title, and interest related to the any Deliverable (including a Deliverable which had not yet been delivered to the City as of the termination). The treatment of termination as “completion of the Services” for this purpose shall not

preclude the City from exercising any right or remedy it has, in law, in equity, or under this Agreement.

Article 11. Ownership of Documents and Intellectual Property

1. Client Content. Client Content, including all pre-existing Trademarks and copyright material, shall remain the sole property of the City, and City shall be the sole owner of all rights in connection therewith. The City hereby grants to Designer a nonexclusive, nontransferable license to use, reproduce, and modify the Client Content solely in connection with Designer's performance of the Designer's Services and the production of the Deliverables.
2. Third Party Materials. All Third Party Materials are the exclusive property of their respective owners. Designer shall inform the City of all Third Party Materials that may be required to perform the Design Services or otherwise integrated into the Final Art. Any licensing costs associated with Designer's use of Third Party Materials shall be the responsibility of Designer.
3. Assignment of Copyrights. Upon completion of each Final Deliverable, Designer hereby assigns to the City all rights (including all ownership rights), title, and interest, including—without limitation—any copyright or other intellectual property rights in and to any artworks or designs comprising the works created by Designer as part of the Final Art and Final Deliverables for use by the City. Designer shall cooperate with the City and shall execute any additional documents reasonably requested by the City to evidence all such assignments of intellectual property.
4. Assignment of Final Art. Upon completion of each Final Deliverable, Designer hereby assigns to the City all rights (including all ownership rights), title, and interest, including—without limitation—copyright and other intellectual property rights in and to the Final Deliverables and the Final Art. Designer shall cooperate with the City and shall execute any additional documents reasonably requested by the City to evidence all such assignments of intellectual property.

Article 10. Identity of Designer

Designer acknowledges that one of the primary reasons for its selection by the City to perform the Services is the qualifications and experience of Designer. Designer thus agrees that the Services to be performed pursuant to this Agreement shall be performed by Designer. Designer shall not subcontract any part of the Services without the prior written permission of the City. The City's project manager shall have the ability to provide this written permission. The City reserves the right to reject any of Designer's personnel or proposed outside professional sub-consultants, and the City reserves the right to request that acceptable replacement personnel be assigned to the project.

Article 11. Independent Contractor Status

During the entire term of this Agreement, Designer shall be an independent contractor, and in no event shall any of its personnel, agents or sub-contractors be construed to be, or represent themselves to be, employees of the City. Designer shall be solely responsible for the payment and reporting of all employee and employer taxes, including social security, unemployment, and any

other federal, state, or local taxes required to be withheld from employees or payable on behalf of its employees.

Article 12. Indemnification

Designer hereby agrees to indemnify, defend, and hold harmless the City, its elected and appointed officials, officers, employees, agents, representatives, and volunteers, and each of them, from and against any and all suits, actions, legal or administrative proceedings, claims, demands, damages, liabilities, interest, attorneys' fees, costs, and expenses of whatsoever kind or nature in any manner directly or indirectly caused, occasioned, or contributed to in whole or in part or claimed to be caused, occasioned, or contributed to in whole or in part, by reason of any act, omission, fault, or negligence, whether active or passive, of Designer or of anyone acting under its direction or control or on its behalf, even if liability is also sought to be imposed on the City, its elected and appointed officials, officers, employees, agents, representatives and volunteers. The obligation to indemnify, defend and hold harmless the City, its elected and appointed officials, officers, employees, agents, representatives and volunteers, and each of them, shall be applicable unless liability results from the sole negligence of the City, its appointed officials, officers, employees, agents, representatives and volunteers.

Designer shall reimburse the City, its elected and appointed officials, officers, employees, agents or authorized representatives or volunteers for any and all legal expenses and costs incurred by each of them in connection therewith or in enforcing the indemnity herein provided.

In the event that Designer employs other persons, firms, corporations or entities (collectively Subcontractor) as part of performing its obligations under this Agreement, it shall be Designer's responsibility to require and confirm that each Subcontractor enters into an Indemnity Agreement in favor of the City, its elected and appointed officials, officers, employees, agents, representatives and volunteers, which is identical to this Indemnity Agreement.

This indemnity provision shall survive the termination or expiration of this Agreement.

Article 13. Insurance

Designer shall not commence work under this Agreement until it has obtained all insurance required under this Article. Additionally, Designer shall not allow any approved subcontractor to commence work on its subcontract until the subcontractor has obtained all insurance required under this Article.

During the performance of any and all Services under this Agreement, Designer shall maintain the following insurance in full force and effect, and shall provide proof of insurance to the City's designated project manager listing the City of Sheboygan as an additional insured:

- a. Commercial General Liability Insurance – Designer shall acquire and maintain, for the duration of the Agreement, Commercial General Liability Insurance of at least \$1,000,000 per occurrence and \$2,000,000 in the aggregate.

- b. Automobile Liability Insurance – Designer shall acquire and maintain, for the duration of the Agreement, Automobile Liability Insurance of at least \$1,000,000.
- c. Workers’ Compensation Insurance – Designer shall acquire and maintain, for the duration of the Agreement, Workers’ Compensation Insurance that meets all statutory requirements. In the event this Agreement authorizes any work to be sublet, Designer shall require any contractor to similarly provide Workers’ Compensation Insurance in accordance with all statutory requirements.

All insurance must be primary and non-contributory to any insurance or self-insurance carried by the City.

The insurance coverage required must be provided by an insurance carrier with the “Best” rating of “A-VII” or better. All carriers shall be admitted carriers in the State of Wisconsin.

Approval of the insurance by the City shall not relieve or decrease the extent to which Designer may be held responsible for payment of damages resulting from Designer’s provision of the Services or its operations under this Agreement. If Designer fails or refuses to procure or maintain the insurance required by these provisions, or fails or refuses to furnish the City the required proof that the insurance has been procured and is in force and paid for, the City shall have the right at its election to terminate the Agreement.

Article 14. Conflict of Interest

Designer declares that it has no present interest, nor shall it acquire any interest, direct or indirect, which would conflict with the performance of Services under this Agreement. Designer agrees that no person having any such interest shall be employed in the performance of this Agreement.

Article 15. Waiver

No failure of either party to enforce a term of this Agreement against the other shall be construed as a waiver of that term, nor shall it in any way affect the party’s right to enforce that term. Any waiver of any term of this Agreement must be in writing. No waiver by any party of any term of this Agreement shall be considered to be a waiver of any other term or breach thereof.

Article 16. Severability

The invalidity, illegality, or unenforceability of any provision of this Agreement, or the occurrence of any event rendering any portion or provision of this Agreement void shall in no way affect the validity or enforceability of any other portion or provision of this Agreement. Any void provision shall be deemed severed from this Agreement, and the balance of the Agreement shall be construed and enforced as if it did not contain the particular provision to be held void. The parties further agree to amend this Agreement to replace any stricken provision with a valid provision that comes as close as possible to the intent of the stricken provision. The provisions of this Article shall not prevent this entire Agreement from being void should a provision which is of the essence of this Agreement be determined void.

Article 17. Assignment

Neither the City nor Designer shall assign any rights or duties under this Agreement without the prior written consent of the other party.

Article 18. Third Party Rights

Nothing in this Agreement shall be construed to give any rights or benefits to anyone other than the City and Designer.

Article 19. Governing Law and Venue

This Agreement shall be governed by the laws of the State of Wisconsin. Venue of any disputes arising under this Agreement shall be in the Sheboygan County Circuit Court, Wisconsin.

Article 20. Non-Discrimination

In connection with the performance of work under this Agreement, Designer agrees not to discriminate against any employee or applicant for employment because of age, race, religion, color, handicap, sex, physical condition, developmental disability (as defined in Wis. Stat. 51.01(5)), sexual orientation (as defined in Wis. Stat. 111.32(13m)), or national origin. This provision shall include, but not be limited to, the following: employment, upgrading, demotion or transfer, recruitment or recruitment advertising, layoff or termination, rates of pay or other forms of compensation, and selection for training, including apprenticeship. Designer further agrees to take affirmative action to ensure equal employment opportunities.

Article 21. Compliance with Laws

In performing the Services under this Agreement, Designer shall comply with any and all applicable federal, state and local statutes, ordinances, plans, and regulations.

The City reserves the right to cancel this Agreement if Designer fails to follow the requirements of Wis. Stat. 77.66 and related statutes regarding certification for collection of sales and use tax.

Designer affirms that it is not presently listed on any debarment list or similar list prohibiting it from contracting with a governmental entity of any kind. In the event that Designer shall become listed on any debarment list or similar list, the City may terminate this Agreement.

Designer shall have any and all licenses and permits required to perform the work specified, and shall furnish proof of such licensing authorization and permits upon request.

Article 22. Notices

Any notice required by this Agreement shall be made in writing to the individuals/addresses specified below:

City:

Designer:

City Clerk	Justin Webb
City of Sheboygan	Sun Graphics Media
828 Center Ave.	1206 N. 8 th Street
Sheboygan, Wisconsin 53083	Sheboygan, Wisconsin 53081

Nothing contained in this Article shall be construed to restrict the transmission of routine communications between representatives of the City and Designer.

Article 23. Intent to be Bound

The City and Designer each binds itself and its successors, executors, administrators, permitted assigns, legal representatives and, in the case of a partnership, its partners to the other party to this Agreement, and to the successors, executors, administrators, permitted assigns, legal representatives and partners of such other party in respect to all provisions of this Agreement.

Article 24. Force Majeure

Neither party shall be in default by reason of any failure in performance of this Agreement in accordance with reasonable control and without fault or negligence on their part. Such causes may include, but are not restricted to, acts of nature or the public enemy, acts of the government in either its sovereign or contractual capacity, fires, floods, epidemics, quarantine restrictions, strikes, freight embargoes, and unusually severe weather. In every case, the failure to perform must be beyond the reasonable control and without the fault or negligence of the party.

In the event the Designer believes the time for completion of the Services in this Agreement should be extended under this Article, Designer shall provide written notice to the City as soon as possible, but not later than seven (7) calendar days after such an event. The notice shall include any justification for an extension of time and shall identify the extension the Designer believes is necessary as a result of the force majeure event.

Article 25. Integration and Modification

This Agreement, including all Exhibits incorporated by reference, represents the entire and integrated agreement between the City and the Designer. It supersedes all prior and contemporaneous communications, representations and agreements, whether oral or written, relating to the subject matter of this Agreement. This Agreement may be modified only by a written amendment signed by both parties hereto.

Article 26. Non-Collusion

Designer is certifying, under penalty of perjury, that to the best of its knowledge and belief:

- a. The prices in its quote were arrived at independently, without collusion, consultation, communication, or agreement, for the purpose of restricting competition as to any other matter relating to such prices with any other competitor.
- b. No attempt was made to induce any other person, partnership, or corporation to submit or not submit a quote to the City for these Services for the purpose of restricting competition.

Article 27. Other Provisions

- a. **Headings.** The numbering and captions of the various sections are solely for convenience and reference and shall not affect the scope, meaning, intent, or interpretation of the provisions of this Agreement, nor shall such headings otherwise be given any legal effect.
- b. **Advertising and News Releases.** Designer retains the right to reproduce, publish and display the Final Deliverables in Designer's portfolio and websites, and in galleries, design periodicals, and other media or exhibits for the sole purpose of recognition of creative excellence or professional advancement, and to be credited with authorship of the Final Deliverables in connection with such uses. Either Party, subject to the other Party's written approval, may include a link to the other Party's website. Reference to or use of the City, or any of its departments, officials, or employees, for commercial promotion is prohibited. News releases pertaining to this procurement shall not be made without prior approval of the City. Release of broadcast e-mails pertaining to this procurement shall not be made without prior written authorization of the City.
- c. **Foreign Corporation.** A foreign corporation (any corporation other than a Wisconsin corporation) which becomes a party to this Agreement is required to conform to all the requirements of Wis. Stat. 180 relating to a foreign corporation, and must possess a certificate of authority from the Wisconsin Department of Financial Institutions, unless the corporation is transacting business in interstate commerce or is otherwise exempt from the requirement of obtaining a certificate of authority.

- d. Authority. Each person executing this Agreement on behalf of a party hereto represents and warrants to the other party: That the execution and delivery of this Agreement has been duly authorized, that the person or persons executing this Agreement have the full power, authority, and right to do so, and that such execution is sufficient and legally binding on such party to enable this Agreement to be enforceable in accordance with its terms.

IN WITNESS WHEREOF, the parties hereto have caused this Agreement to be executed the day and year first written above.

CITY OF SHEBOYGAN, WISCONSIN

SUN GRAPHICS MEDIA

BY: _____
Michael J. Vandersteen, Mayor

BY: _____
Justin Webb

ATTEST: _____
Meredith DeBruin, City Clerk

DATE: _____

DATE: _____

III

Res. No. 193 - 18 - 19. By Alderpersons Rindfleisch and Bohren.
March 18, 2019.

A RESOLUTION authorizing the appropriate City officials to enter into a contract with Mike Koenig Construction, Inc. for the installation of new signage at the SouthPointe Enterprise Campus.

WHEREAS, the 2019 Capital Improvements Budget contemplates the City taking additional steps to establish and develop the SouthPointe Enterprise Campus, including the installation of two large electronic messaging boards on reinforced concrete and masonry bases and related electronic connections, erosion control, grading, landscaping and restoration (the "Project"); and

WHEREAS, the City engaged the services of Ruekert & Mielke, Inc. to develop plans and specifications for the Project; and

WHEREAS, City Staff has obtained and reviewed competitive bids for the Project; and

WHEREAS, the low bid was unresponsive because it only included the electronic signage portion of the project; and

WHEREAS, City Staff has reviewed the other bids, and determined that the lowest responsive bid, submitted by Mike Koenig Construction Co., Inc., meets all of the requirements from the bid documents; and

WHEREAS, the Common Council of the City of Sheboygan believes that it is in the best interest of the City to award a contract to Mike Koenig Construction Co., Inc. for the Project; and

WHEREAS, one prerequisite for the construction of the Project is the receipt of a permit from the Department of Transportation; and

WHEREAS, the City has applied for a permit from the Department of Transportation, but has not yet received that permit.

NOW, THEREFORE, BE IT RESOLVED: That upon receipt of a permit for the Project from the Department of Transportation, the appropriate City officials are authorized to enter into the attached contract in substantially similar form with Mike Koenig Construction, Inc. for the installation of the Project at the SouthPointe Enterprise Campus.

Finance and Personnel

BE IT FURTHER RESOLVED: That the appropriate City Officials are hereby authorized to draw funds in the amount of \$255,400.00 from the TID 18 Capital Project Fund - Improvements other than Buildings Account No. 42861100-631100 for the project.

I HEREBY CERTIFY that the foregoing Resolution was duly passed by the Common Council of the City of Sheboygan, Wisconsin, on the _____ day of _____, 20____.

Dated _____ 20____. _____, City Clerk

Approved _____ 20____. _____, Mayor

AGREEMENT

THIS AGREEMENT is by and between the City of Sheboygan ("Owner") and _____ ("Contractor").

Owner and Contractor hereby agree as follows:

ARTICLE 1 - WORK

- 1.01 Contractor shall complete all Work as specified or indicated in the Contract Documents. The Work is generally described as follows:

Furnishing and construction of two masonry and reinforced concrete monument signs including signage, electronic messaging board, electrical work, grading, erosion control, landscaping and restoration.

ARTICLE 2 - THE PROJECT

- 2.01 The Project for which the Work under the Contract Documents is a part is generally described as follows:

SouthPointe Enterprise Campus - Monument Signage and Landscaping

ARTICLE 3 - ENGINEER

- 3.01 The Project has been designed by Ruekert & Mielke, Inc.
- 3.02 The Owner has retained Ruekert & Mielke, Inc. ("Engineer") to act as Owner's representative, assume all duties and responsibilities, and have the rights and authority assigned to Engineer in the Contract Documents in connection with the completion of the Work in accordance with the Contract Documents.

ARTICLE 4 - CONTRACT TIMES

- 4.01 Time of the Essence
- A. All time limits for Milestones, if any, Substantial Completion, and completion and readiness for final payment as stated in the Contract Documents are of the essence of the Contract.
- 4.02 Days to Achieve Substantial Completion and Final Payment
- A. The Work will be substantially completed within 120 days after the date when the Contract Times commence to run as provided in Paragraph 4.01 of the General Conditions, and completed and ready for final payment in accordance with Paragraph 15.06 of the General Conditions within 130 days after the date when the Contract Times commence to run.
- 4.03 Liquidated Damages
- A. Contractor and Owner recognize that time is of the essence as stated in Paragraph 4.01 above and that Owner will suffer financial and other losses if the Work is not completed and Milestones not achieved within the times specified in Paragraph 4.02 above, plus any extensions thereof allowed in accordance with the Contract. The parties also recognize the delays, expense and difficulties involved in proving in a legal or arbitration proceeding the actual loss suffered by Owner if the Work is not completed on time. Accordingly, instead of

requiring any such proof, Owner and Contractor agree that as liquidated damages for delay (but not as a penalty):

1. *Substantial Completion:* Contractor shall pay Owner \$420 for each day that expires after the time (as duly adjusted pursuant to the Contract) specified in Paragraph 4.02.A. above for Substantial Completion until the Work is substantially complete.
2. *Completion of Remaining Work:* After Substantial Completion, if Contractor shall neglect, refuse, or fail to complete the remaining Work within the Contract Times (as duly adjusted pursuant to the Contract) for completion and readiness for final payment, Contractor shall pay Owner \$100 for each day that expires after such time until the Work is completed and ready for final payment.
3. Liquidated damages for failing to timely attain Substantial Completion and final completion are not additive and will be imposed concurrently.

ARTICLE 5 - CONTRACT PRICE

5.01 Owner shall pay Contractor for completion of the Work in accordance with the Contract Documents for the following prices:

A. Lump Sum Bid Price: \$ _____

ARTICLE 6 - PAYMENT PROCEDURES

6.01 Submittal and Processing of Payments

A. Contractor shall submit Applications for Payment in accordance with Article 15 of the General Conditions. Applications for Payment will be processed by Engineer as provided in the General Conditions.

6.02 Progress Payments; Retainage

A. Owner shall make progress payments on account of the Contract Price on the basis of Contractor's Applications for Payment once each month during performance of the Work as provided in Paragraph 6.02.A.1 below. All such payments will be measured by the Schedule of Values established as provided in the General Conditions (and in the case of Unit Price Work based on the number of units completed) or, in the event there is no Schedule of Values, as provided elsewhere in the Contract.

1. Prior to Substantial Completion, progress payments will be made in an amount equal to the percentage indicated below, but in each case, less the aggregate of payments previously made and less such amounts as Owner may withhold, including but not limited to liquidated damages, in accordance with the Contract.

a. Ninety-five percent of Work completed (with the balance being retainage). If the Work has been 50 percent completed as determined by Engineer, and if the character and progress of the Work have been satisfactory to Owner and Engineer, then as long as the character and progress of the Work remain satisfactory to Owner and Engineer, there will be no additional retainage.

B. Upon Substantial Completion, Owner shall pay an amount sufficient to increase total payments to Contractor to 100 percent of the Work completed, less such amounts as Engineer shall determine in accordance with Paragraph 15.01.C.6 of the General Conditions and less 200 percent of Engineer's estimate of the value of Work to be

completed or corrected as shown on the punch list of items to be completed or corrected prior to final payment.

1. Prior to Owner reducing any retainage amount, Contractor shall furnish consent of surety to reduction in retainage.

6.03 Final Payment

- A. Upon final completion and acceptance of the Work in accordance with Paragraph 15.06 of the General Conditions, Owner shall pay the remainder of the Contract Price as recommended by Engineer as provided in said Paragraph 15.06.

ARTICLE 7 - INTEREST

- 7.01 All moneys not paid when due as provided in Article 15 of the General Conditions shall bear interest at the statutory rate of the State of Wisconsin.

ARTICLE 8 - CONTRACTOR'S REPRESENTATIONS

- 8.01 In order to induce Owner to enter into this Contract, Contractor makes the following representations:
 - A. Contractor has examined and carefully studied the Contract Documents, and any data and reference items identified in the Contract Documents.
 - B. Contractor has visited the Site, conducted a thorough, alert visual examination of the Site and adjacent areas, and become familiar with and is satisfied as to the general, local, and Site conditions that may affect cost, progress, and performance of the Work.
 - C. Contractor is familiar with and is satisfied as to all Laws and Regulations that may affect cost, progress, and performance of the Work.
 - D. Contractor has carefully studied all: (1) reports of explorations and tests of subsurface conditions at or adjacent to the Site and all drawings of physical conditions relating to existing surface or subsurface structures at the Site that have been identified in the Supplementary Conditions, especially with respect to Technical Data in such reports and drawings, and (2) reports and drawings relating to Hazardous Environmental Conditions, if any, at or adjacent to the Site that have been identified in the Supplementary Conditions, especially with respect to Technical Data in such reports and drawings.
 - E. Contractor has considered the information known to Contractor itself; information commonly known to contractors doing business in the locality of the Site; information and observations obtained from visits to the Site; the Contract Documents; and any Site-related reports and drawings identified in the Contract Documents, with respect to the effect of such information, observations, and documents on (1) the cost, progress, and performance of the Work; (2) the means, methods, techniques, sequences, and procedures of construction to be employed by Contractor; and (3) Contractor's safety precautions and programs.
 - F. Based on the information and observations referred to in the preceding paragraph, Contractor agrees that no further examinations, investigations, explorations, tests, studies, or data are necessary for the performance of the Work at the Contract Price, within the Contract Times, and in accordance with the other terms and conditions of the Contract.
 - G. Contractor is aware of the general nature of work to be performed by Owner and others at the Site that relates to the Work as indicated in the Contract Documents.

00 52 00-3

02/08/19

~8000 10001 SouthPointe Enterprise Campus > 212 Monument Signage and Landscaping > Project Manual > 00 52 00 Agreement.docx--> |00 52 00 Agreement.Docx

Ruekert & Mielke, Inc.

- H. Contractor has given Engineer written notice of all conflicts, errors, ambiguities, or discrepancies that Contractor has discovered in the Contract Documents, and the written resolution thereof by Engineer is acceptable to Contractor.
- I. The Contract Documents are generally sufficient to indicate and convey understanding of all terms and conditions for performance and furnishing of the Work.
- J. Contractor's entry into this Contract constitutes an incontrovertible representation by Contractor that without exception all prices in this Agreement are premised upon performing and furnishing the Work required by the Contract Documents.

ARTICLE 9 - CONTRACT DOCUMENTS

9.01 Contents

- A. The Contract Documents consist of the following:
 - 1. This Agreement (pages 00 52 00-1 to 00 52 00-7, inclusive).
 - 2. Performance bond (pages 00 61 13.13-1 to 00 61 13.13-2, inclusive).
 - 3. Payment bond (pages 00 61 13.16-1 to 00 61 13.16-2 inclusive).
 - 4. General Conditions (pages 00 72 00-1 to 00 72 00-72, inclusive).
 - 5. Supplementary Conditions (pages 00 73 00-1 to 00 73 00-13, inclusive).
 - 6. Specifications as listed in the table of contents of the Project Manual.
 - 7. Drawings listed on the attached sheet index.
 - 8. Addenda (numbers __ to __, inclusive).
 - 9. Exhibits to this Agreement (enumerated as follows):
 - a. Contractor's Bid (pages 00 41 00-1 to 00 41 00-5, inclusive).
 - b. Documentation submitted by Contractor prior to Notice of Award (pages _____ to _____, inclusive).
 - 10. The following which may be delivered or issued on or after the Effective Date of the Contract and are not attached hereto:
 - a. Notice to Proceed.
 - b. Work Change Directives.
 - c. Change Orders.
 - d. Field Orders.
- B. The documents listed in Paragraph 9.01.A are attached to this Agreement (except as expressly noted otherwise above).
- C. There are no Contract Documents other than those listed above in this Article 9.

- D. The Contract Documents may only be amended, modified, or supplemented as provided in the General Conditions.

ARTICLE 10 - MISCELLANEOUS

10.01 Terms

- A. Terms used in this Agreement will have the meanings stated in the General Conditions and the Supplementary Conditions.

10.02 Assignment of Contract

- A. Unless expressly agreed to elsewhere in the Contract, no assignment by a party hereto of any rights under or interests in the Contract will be binding on another party hereto without the written consent of the party sought to be bound; and, specifically but without limitation, money that may become due and money that is due may not be assigned without such consent (except to the extent that the effect of this restriction may be limited by law), and unless specifically stated to the contrary in any written consent to an assignment, no assignment will release or discharge the assignor from any duty or responsibility under the Contract.

10.03 Successors and Assigns

- A. Owner and Contractor each binds itself, its partners, successors, assigns, and legal representatives to the other party hereto, its successors, assigns, and legal representatives in respect to all covenants, agreements, and obligations contained in the Contract.

10.04 Severability

- A. Any provision or part of the Contract Documents held to be void or unenforceable under any Law or Regulation shall be deemed stricken, and all remaining provisions shall continue to be valid and binding upon Owner and Contractor, who agree that the Contract Documents shall be reformed to replace such stricken provision or part thereof with a valid and enforceable provision that comes as close as possible to expressing the intention of the stricken provision.

10.05 Contractor's Certifications

- A. Contractor certifies that it has not engaged in corrupt, fraudulent, collusive, or coercive practices in competing for or in executing the Contract. For the purposes of this Paragraph 10.05:
1. "corrupt practice" means the offering, giving, receiving, or soliciting of any thing of value likely to influence the action of a public official in the bidding process or in the Contract execution;
 2. "fraudulent practice" means an intentional misrepresentation of facts made (a) to influence the bidding process or the execution of the Contract to the detriment of Owner, (b) to establish Bid or Contract prices at artificial non-competitive levels, or (c) to deprive Owner of the benefits of free and open competition;
 3. "collusive practice" means a scheme or arrangement between two or more Bidders, with or without the knowledge of Owner, a purpose of which is to establish Bid prices at artificial, non-competitive levels; and

4. "coercive practice" means harming or threatening to harm, directly or indirectly, persons or their property to influence their participation in the bidding process or affect the execution of the Contract.

10.06 Other Provisions: None

IN WITNESS WHEREOF, Owner and Contractor have signed 2 copies of this Agreement. Counterparts have been delivered to Owner and Contractor. All portions of the Contract Documents have been signed or have been identified by Owner and Contractor or on their behalf.

This Agreement will be effective on _____ (which is the Effective Date of the Contract).

OWNER:

CONTRACTOR:

For: CITY OF SHEBOYGAN

For: _____

By: _____
(Signature)

By: _____
(Signature)

(Print Name)

(Print Name)

Title: _____

Title: _____

(If Contractor is a corporation, a partnership, or a joint venture, attach evidence of authority to sign.)

Attest: _____

Attest: _____

Title: _____

Title: _____

Address for giving notices:

Address for giving notices:

828 CENTER AVENUE
SHEBOYGAN, WI 53081

This is to certify that provisions have been made to pay the expense that will accrue under this Contract.

Clerk, Treasurer, or other designated Official

Approved as to form:

(Attorney for Owner)

00 52 00-7

02/08/19

~8000 10001 SouthPointe Enterprise Campus > 212 Monument Signage and Landscaping > Project Manual > 00 52 00 Agreement.docx-> |00 52 00 Agreement.Docx

Ruekert & Mielke, Inc.

R. C. No. _____ - 18 - 19. By FINANCE AND PERSONNEL COMMITTEE.
March 18, 2019.

Your Committee to whom was referred Res. No. 182-18-19 by Alderpersons Rindfleisch and Bohren authorizing the appropriate City officials to execute the PILOT Agreement between the City of Sheboygan, Wasserman Redevelopment, LLC, and the Housing Authority of the City of Sheboygan, Wisconsin, with regard to the Housing Authority rental project located at 611 North Water Street; recommends approving the Resolution with amended agreement.

Reg.

_____ Committee

I HEREBY CERTIFY that the foregoing Committee Report was duly accepted and adopted by the Common Council of the City of Sheboygan, Wisconsin, on the _____ day of _____, 20____.

Dated _____ 20____, _____, City Clerk

Approved _____ 20____, _____, Mayor

III

5.4

Res. No. 182 - 18 - 19. By Alderpersons Rindfleisch and Bohren.
March 4, 2019.

A RESOLUTION authorizing the appropriate City officials to execute the PILOT Agreement between the City of Sheboygan, Wasserman Redevelopment, LLC, and the Housing Authority of the City of Sheboygan, Wisconsin, with regard to the Housing Authority rental project located at 611 North Water Street.

RESOLVED: That the Mayor, City Clerk, and City Attorney are hereby authorized to execute the PILOT Agreement between the City of Sheboygan, Wasserman Redevelopment, LLC, and the Housing Authority of the City of Sheboygan, Wisconsin, in form substantially similar to the attached.

Ronald Rindfleisch
James A. Bohren

*Finance & Personnel
Approve w/ amended
agreement*

I HEREBY CERTIFY that the foregoing Resolution was duly passed by the Common Council of the City of Sheboygan, Wisconsin, on the _____ day of _____, 20____.

Dated _____ 20____. _____, City Clerk

Approved _____ 20____. _____, Mayor

PILOT AGREEMENT

This PILOT Agreement (“**Agreement**”) is entered into effective April 1, 2019, by and among the City of Sheboygan, Wisconsin (the “**City**”), Wasserman Redevelopment, LLC, a Wisconsin limited liability company (the “**Company**”) and The Housing Authority of the City of Sheboygan, Wisconsin a/k/a Sheboygan Housing Authority, a public body, corporate and politic, organized and existing under the laws of the State of Wisconsin (the “**Housing Authority**”).

RECITALS

WHEREAS, the Housing Authority has owned and operated a 105-unit HUD tenant protection voucher rental project (the “**Project**”) located at 611 North Water Street, Sheboygan, Wisconsin 53081 more particularly described in the attached Exhibit A (referred to herein as the “**Property**”); and

WHEREAS, in order to raise debt and equity capital for the substantial rehabilitation and construction of the Property, the Housing Authority anticipates transferring fee simple ownership of the Property to the Company in 2019; and

WHEREAS, the Housing Authority is the managing member of the Company and the property manager of the Project, and, as such, exercises exclusive control and authority over the operation of the Project; and

WHEREAS, the Housing Authority has loaned substantial sums to the Company in connection with the acquisition and rehabilitation/construction of the Project, and has a right of first refusal to acquire the Project for a nominal sum following the expiration of the fifteen (15)-year low-income housing tax compliance period (the “**Compliance Period**”); and

WHEREAS, the Company is obligated to operate the Project as affordable housing in compliance with HUD, Internal Revenue Code, and Wisconsin Housing and Economic Development Authority restrictions and requirements, and the Housing Authority is solely responsible for ensuring that such restrictions and requirements are satisfied by the Company throughout the Compliance Period; and

WHEREAS, the Company will not generate material positive cash flow in excess of its fixed expenses, fees and debt obligations; and

WHEREAS, the parties have determined, based upon the foregoing RECITALS, that the Project constitutes property of the Housing Authority that is exempt from taxation under Section 70.11(18) of the Wisconsin Statutes and which may be subject to a payment in lieu of taxes (“**PILOT**”) imposed by the City, as provided in Section 66.1201(22) of the Wisconsin Statutes;

NOW, THEREFORE, acknowledging the receipt of sufficient consideration, the parties agree as follows:

1. Term of PILOT Agreement. The Company shall make a PILOT to the City with respect to the Project for each calendar year beginning in 2019 and ending in the final calendar year of the Project’s Compliance Period, now estimated to be calendar year 2035. As required by

Section 66.1201(22) of the Wisconsin Statutes, such PILOT shall not exceed the amount that would be levied as the annual tax of the City upon the Project.

2. Computation of PILOT. The PILOT for each calendar year shall be ten percent (10%) of the difference between (a) one hundred percent (100%) of the tenant's portion of the collected rents for all of the residential rental units in the Project for such calendar year; and (b) one hundred percent (100%) of the electricity, water, sewer and fuel bills incurred by the Company with respect to the Project for such calendar year. The amounts under clauses (a) and (b) above shall be based upon the financial statements of the Company for the prior calendar year.

3. Payment of PILOT. The Company shall make the PILOT within the time periods applicable to properties that are not exempt from property taxation, as provided in Section 74.11 of the Wisconsin Statutes.

4. Obligation of Company and Housing Authority. The Housing Authority shall cause the Company to rehabilitate and operate the Project as affordable rental housing in accordance with the income, rent and other restrictions and limitations imposed by HUD, the Internal Revenue Code and the Wisconsin Housing and Economic Development Authority.

5. Obligations of City. The City shall furnish or cause to be furnished to the Company and/or Project tenants such services or facilities as are furnished to other property owners and residents of the City on the same basis as such City services are ordinarily provided. The City shall also, to the extent permitted by applicable law, apply or modify existing City codes and ordinances to permit the Housing Authority and the Company to operate the Project as described above throughout the Compliance Period.

6. Termination of Compliance Period. As noted in Paragraph 1 the final year of the Project's Compliance Period is estimated to be 2035. The Company and the Housing Authority shall, no earlier than 12 months and no later than six months before the beginning of the final calendar year, inform the City in writing that the following year is the last year of the Compliance Period. Upon such notice, the parties shall negotiate in good faith a new PILOT Agreement. If the parties cannot agree on a new PILOT Agreement, the Company, or its successor in interest, shall continue to pay a PILOT pursuant to the terms of this Agreement.

7. Miscellaneous. This Agreement cannot be unilaterally amended, modified or terminated by any party hereto. Each party hereby represents to and for the benefit of the other party that the person executing this Agreement on the signature page on behalf of such party has been duly authorized to execute this Agreement, and that this Agreement has been duly authorized and approved by such party. The benefits of this Agreement shall not be assigned by the Company or the Housing Authority without City's consent. This Agreement represents the entire agreement of the parties with respect to the subject matter hereof. This Agreement shall be governed by the laws of the State of Wisconsin. This Agreement may be signed by facsimile or in counterparts.

[SIGNATURE PAGE FOLLOWS]

IN WITNESS WHEREOF, the parties hereto duly execute this PILOT Agreement effective as of the date first set forth above.

CITY OF SHEBOYGAN

By: _____
Name: Mike Vandersteen
Its: Mayor

By: _____
Name: Meredith DeBuin
Its: City Clerk

By: _____
Name: Charles C. Adams
Its: City Attorney

THE HOUSING AUTHORITY OF THE CITY OF SHEBOYGAN, WISCONSIN A/K/A SHEBOYGAN HOUSING AUTHORITY

a public body, corporate and politic, organized and existing under the laws of the State of Wisconsin

By: _____
Name: Joseph Rupnik
Its: Executive Director

WASSERMAN REDEVELOPMENT, LLC

a Wisconsin limited liability company

By: The Housing Authority of the City of Sheboygan, Wisconsin,
a public body, corporate and politic, organized and existing under the laws of the State of Wisconsin
Its: Managing Member

By: _____
Name: Joseph Rupnik
Its: Executive Director

EXHIBIT A

PROJECT

105 apartment units located at 611 North Water Street, Sheboygan, Wisconsin 53081 more particularly described as:

Legal Description

Tax Parcel No. 59281107830

THE WEST 40 FEET OF LOT 4, ALL OF LOTS 5, 6, 7, 8, 9, AND 10, IN BLOCK 150, ORIGINAL PLAT OF THE CITY OF SHEBOYGAN, SHEBOYGAN COUNTY, WISCONSIN, AND MORE PARTICULARLY DESCRIBED AS FOLLOWS: BEGINNING AT AN IRON PIPE SET AT THE POINT OF INTERSECTION OF THE SOUTH LINE OF NEW YORK AVENUE WITH THE EAST LINE OF NORTH 10TH STREET, SAID POINT ALSO BEING THE NORTHWEST CORNER OF LOT 6 IN SAID BLOCK 150. THENCE, FROM SAID POINT OF BEGINNING, ON AN ASSUMED BEARING OF SOUTH 0°15'36" EAST, COINCIDENT WITH THE EAST LINE OF SAID NORTH 10TH ST., A DISTANCE OF 168.01 FEET TO AN IRON PIPE SET AT THE POINT OF INTERSECTION OF THE EAST LINE OF SAID NORTH 10TH STREET WITH THE NORTHEASTERLY LINE OF NORTH WATER STREET; THENCE, SOUTH 35°53'57" EAST, COINCIDENT WITH THE NORTHEASTERLY LINE OF SAID NORTH WATER ST., A DISTANCE OF 185.68 FEET TO A CHISELED CROSS MARKING, THE POINT OF INTERSECTION OF THE NORTHEASTERLY LINE OF SAID NORTH WATER ST. WITH THE NORTH LINE OF SAID CENTER AVENUE; THENCE, SOUTH 89°45'02" EAST, COINCIDENT WITH THE NORTH LINE OF SAID CENTER AVENUE, A DISTANCE OF 132.00 FEET TO AN IRON PIPE SET AT THE POINT OF INTERSECTION OF THE NORTH LINE OF SAID CENTER AVENUE WITH THE EAST LINE OF LOT 10 IN SAID BLOCK 150, THENCE, NORTH 0°06'37" WEST, COINCIDENT WITH THE EAST LINE OF SAID LOT 10, A DISTANCE OF 150.77 FEET TO AN IRON PIPE SET AT THE POINT OF INTERSECTION OF THE EAST LINE OF SAID LOT 10 WITH THE SOUTH LINE OF AN EAST-WEST ALLEY; THENCE, NORTH 89°38'51" WEST, COINCIDENT WITH THE SOUTH LINE OF SAID ALLEY, A DISTANCE 80.20 FEET TO AN IRON PIPE SET AT THE POINT OF INTERSECTION OF THE SOUTH LINE OF SAID ALLEY WITH THE EAST LINE OF THE WEST 40.00 FEET OF LOT 4, SAID BLOCK, 150, EXTENDED; THENCE NORTH 0°08'37" WEST, COINCIDENT WITH THE EAST LINE OF THE WEST 40.00 FEET OF SAID LOT 4, AND ITS EXTENSION, A DISTANCE OF 18.00 FEET TO AN IRON PIPE SET AT THE POINT OF INTERSECTION OF THE EAST LINE OF THE WEST 40.00 FEET OF SAID LOT 4, WITH THE NORTH LINE OF SAID ALLEY; THENCE, CONTINUING NORTH 0°08'37" WEST, COINCIDENT WITH THE EAST LINE OF THE WEST 40.00 FEET OF SAID LOT 4, A DISTANCE 149.56 FEET TO AN IRON PIPE SET AT THE POINT OF INTERSECTION OF THE EAST LINE OF THE WEST 40.00 FEET OF SAID LOT 4, WITH THE SOUTH LINE OF SAID NEW YORK AVENUE; THENCE, NORTH 89°55'58" WEST, COINCIDENT WITH THE SOUTH LINE OF SAID NEW YORK AVENUE, A DISTANCE OF 160.73 FEET TO THE POINT OF BEGINNING. ALSO THE WEST 160 FEET OF THE ALLEY IN BLOCK 150 PER RESOLUTION RECORDED AUGUST 27, 1969 IN VOLUME 583 OF RECORDS, PAGE 86 AS DOCUMENT NO. 917147.

PILOT AGREEMENT

This PILOT Agreement (“**Agreement**”) is entered into effective April 1, 2019, by and among the City of Sheboygan, Wisconsin (the “**City**”), Wasserman Redevelopment, LLC, a Wisconsin limited liability company (the “**Company**”) and The Housing Authority of the City of Sheboygan, Wisconsin a/k/a Sheboygan Housing Authority, a public body, corporate and politic, organized and existing under the laws of the State of Wisconsin (the “**Housing Authority**”).

RECITALS

WHEREAS, the Housing Authority has owned and operated a 105-unit HUD tenant protection voucher rental project (the “**Project**”) located at 611 North Water Street, Sheboygan, Wisconsin 53081 more particularly described in the attached Exhibit A (referred to herein as the “**Property**”); and

WHEREAS, in order to raise debt and equity capital for the substantial rehabilitation and construction of the Property, the Housing Authority anticipates transferring fee simple ownership of the Property to the Company in 2019; and

WHEREAS, the Housing Authority is the managing member of the Company and the property manager of the Project, and, as such, exercises exclusive control and authority over the operation of the Project; and

WHEREAS, the Housing Authority has loaned substantial sums to the Company in connection with the acquisition and rehabilitation/construction of the Project, and has a right of first refusal to acquire the Project for a nominal sum following the expiration of the fifteen (15)-year low-income housing tax compliance period (the “**Compliance Period**”); and

WHEREAS, the Company is obligated to operate the Project as affordable housing in compliance with HUD, Internal Revenue Code, and Wisconsin Housing and Economic Development Authority restrictions and requirements, and the Housing Authority is solely responsible for ensuring that such restrictions and requirements are satisfied by the Company throughout the Compliance Period; and

WHEREAS, the Company will not generate material positive cash flow in excess of its fixed expenses, fees and debt obligations; and

WHEREAS, the parties have determined, based upon the foregoing RECITALS, that the Project constitutes property of the Housing Authority that is exempt from taxation under Section 70.11(18) of the Wisconsin Statutes and which may be subject to a payment in lieu of taxes (“**PILOT**”) imposed by the City, as provided in Section 66.1201(22) of the Wisconsin Statutes;

NOW, THEREFORE, acknowledging the receipt of sufficient consideration, the parties agree as follows:

1. Term of PILOT Agreement. The Company shall make a PILOT to the City with respect to the Project for each calendar year beginning in 2019 and ending in the final calendar year of the Project’s Compliance Period, now estimated to be calendar year 2035. As required by

Section 66.1201(22) of the Wisconsin Statutes, such PILOT shall not exceed the amount that would be levied as the annual tax of the City upon the Project.

2. Computation of PILOT. The PILOT for each calendar year shall be ten percent (10%) of the difference between (a) one hundred percent (100%) of the tenant's portion of the collected rents for all of the residential rental units in the Project for such calendar year; and (b) one hundred percent (100%) of the electricity, water, sewer and fuel bills incurred by the Company with respect to the Project for such calendar year. The amounts under clauses (a) and (b) above shall be based upon the financial statements of the Company for the prior calendar year.

3. Payment of PILOT. The Company shall make the PILOT within the time periods applicable to properties that are not exempt from property taxation, as provided in Section 74.11 of the Wisconsin Statutes.

4. Obligation of Company and Housing Authority. The Housing Authority shall cause the Company to rehabilitate and operate the Project as affordable rental housing in accordance with the income, rent and other restrictions and limitations imposed by HUD, the Internal Revenue Code and the Wisconsin Housing and Economic Development Authority.

5. Obligations of City. The City shall furnish or cause to be furnished to the Company and/or Project tenants such services or facilities as are furnished to other property owners and residents of the City on the same basis as such City services are ordinarily provided. The City shall also, to the extent permitted by applicable law, apply or modify existing City codes and ordinances to permit the Housing Authority and the Company to operate the Project as described above throughout the Compliance Period.

6. Termination of Compliance Period. As noted in Paragraph 1 the final year of the Project's Compliance Period is estimated to be 2035. The Company and the Housing Authority shall, no earlier than 12 months and no later than six months before the beginning of the final calendar year, inform the City in writing that the following year is the last year of the Compliance Period. Upon such notice, the parties shall negotiate in good faith a new PILOT Agreement. If the parties cannot agree on a new PILOT Agreement, the Company, or its successor in interest, shall continue to pay a PILOT pursuant to the terms of this Agreement.

7. Miscellaneous. This Agreement cannot be unilaterally amended, modified or terminated by any party hereto. Each party hereby represents to and for the benefit of the other party that the person executing this Agreement on the signature page on behalf of such party has been duly authorized to execute this Agreement, and that this Agreement has been duly authorized and approved by such party. The benefits of this Agreement shall not be assigned by the Company or the Housing Authority without City's consent. This Agreement represents the entire agreement of the parties with respect to the subject matter hereof. This Agreement shall be governed by the laws of the State of Wisconsin. This Agreement may be signed by facsimile or in counterparts.

[SIGNATURE PAGE FOLLOWS]

IN WITNESS WHEREOF, the parties hereto duly execute this PILOT Agreement effective as of the date first set forth above.

CITY OF SHEBOYGAN

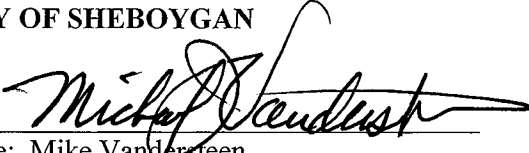
By: 
Name: Mike Vandersteen
Its: Mayor

By: 
Name: Meredith DeBuin
Its: City Clerk

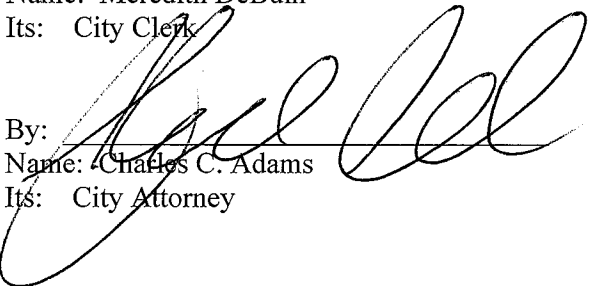
By: 
Name: Charles C. Adams
Its: City Attorney

THE HOUSING AUTHORITY OF THE CITY OF SHEBOYGAN, WISCONSIN A/K/A SHEBOYGAN HOUSING AUTHORITY
a public body, corporate and politic, organized and existing under the laws of the State of Wisconsin

By: 
Name: Joseph Rupnik
Its: Executive Director

WASSERMAN REDEVELOPMENT, LLC

a Wisconsin limited liability company
By: The Housing Authority of the City of Sheboygan, Wisconsin,
a public body, corporate and politic, organized and existing under the laws of the State of Wisconsin
Its: Managing Member

By: 
Name: Joseph Rupnik
Its: Executive Director

EXHIBIT A

PROJECT

105 apartment units located at 611 North Water Street, Sheboygan, Wisconsin 53081 more particularly described as:

Legal Description

Tax Parcel No. 59281107830

THE WEST 40 FEET OF LOT 4, ALL OF LOTS 5, 6, 7, 8, 9, AND 10, IN BLOCK 150, ORIGINAL PLAT OF THE CITY OF SHEBOYGAN, SHEBOYGAN COUNTY, WISCONSIN, AND MORE PARTICULARLY DESCRIBED AS FOLLOWS: BEGINNING AT AN IRON PIPE SET AT THE POINT OF INTERSECTION OF THE SOUTH LINE OF NEW YORK AVENUE WITH THE EAST LINE OF NORTH 10TH STREET, SAID POINT ALSO BEING THE NORTHWEST CORNER OF LOT 6 IN SAID BLOCK 150. THENCE, FROM SAID POINT OF BEGINNING, ON AN ASSUMED BEARING OF SOUTH 0°15'36" EAST, COINCIDENT WITH THE EAST LINE OF SAID NORTH 10TH ST., A DISTANCE OF 168.01 FEET TO AN IRON PIPE SET AT THE POINT OF INTERSECTION OF THE EAST LINE OF SAID NORTH 10TH STREET WITH THE NORTHEASTERLY LINE OF NORTH WATER STREET; THENCE, SOUTH 35°53'57" EAST, COINCIDENT WITH THE NORTHEASTERLY LINE OF SAID NORTH WATER ST., A DISTANCE OF 185.68 FEET TO A CHISELED CROSS MARKING, THE POINT OF INTERSECTION OF THE NORTHEASTERLY LINE OF SAID NORTH WATER ST. WITH THE NORTH LINE OF CENTER AVENUE; THENCE, SOUTH 89°45'02" EAST, COINCIDENT WITH THE NORTH LINE OF SAID CENTER AVENUE, A DISTANCE OF 132.00 FEET TO AN IRON PIPE SET AT THE POINT OF INTERSECTION OF THE NORTH LINE OF SAID CENTER AVENUE WITH THE EAST LINE OF LOT 10 IN SAID BLOCK 150, THENCE, NORTH 0°06'37" WEST, COINCIDENT WITH THE EAST LINE OF SAID LOT 10, A DISTANCE OF 150.77 FEET TO AN IRON PIPE SET AT THE POINT OF INTERSECTION OF THE EAST LINE OF SAID LOT 10 WITH THE SOUTH LINE OF AN EAST-WEST ALLEY; THENCE, NORTH 89°38'51" WEST, COINCIDENT WITH THE SOUTH LINE OF SAID ALLEY, A DISTANCE 80.20 FEET TO AN IRON PIPE SET AT THE POINT OF INTERSECTION OF THE SOUTH LINE OF SAID ALLEY WITH THE EAST LINE OF THE WEST 40.00 FEET OF LOT 4, SAID BLOCK, 150, EXTENDED; THENCE NORTH 0°08'37" WEST, COINCIDENT WITH THE EAST LINE OF THE WEST 40.00 FEET OF SAID LOT 4, AND ITS EXTENSION, A DISTANCE OF 18.00 FEET TO AN IRON PIPE SET AT THE POINT OF INTERSECTION OF THE EAST LINE OF THE WEST 40.00 FEET OF SAID LOT 4, WITH THE NORTH LINE OF SAID ALLEY; THENCE, CONTINUING NORTH 0°08'37" WEST, COINCIDENT WITH THE EAST LINE OF THE WEST 40.00 FEET OF SAID LOT 4, A DISTANCE 149.56 FEET TO AN IRON PIPE SET AT THE POINT OF INTERSECTION OF THE EAST LINE OF THE WEST 40.00 FEET OF SAID LOT 4, WITH THE SOUTH LINE OF SAID NEW YORK AVENUE; THENCE, NORTH 89°55'58" WEST, COINCIDENT WITH THE SOUTH LINE OF SAID NEW YORK AVENUE, A DISTANCE OF 160.73 FEET TO THE POINT OF BEGINNING. ALSO THE WEST 160 FEET OF THE ALLEY IN BLOCK 150 PER RESOLUTION RECORDED AUGUST 27, 1969 IN VOLUME 583 OF RECORDS, PAGE 86 AS DOCUMENT NO. 917147.

R. C. No. _____ - 18 - 19. By LICENSING, HEARINGS, AND PUBLIC SAFETY COMMITTEE. March 18, 2019.

Your Committee to whom was referred Res. No. 183-18-19 by Alderpersons Wolf and Donohue dissolving the Sustainable Sheboygan Task Force; recommends approving the Substitute Resolution.

Reg.

_____	_____
_____	_____
_____	_____

Committee

I HEREBY CERTIFY that the foregoing Committee Report was duly accepted and adopted by the Common Council of the City of Sheboygan, Wisconsin, on the _____ day of _____, 20____.

Dated _____ 20____. _____, City Clerk

Approved _____ 20____. _____, Mayor

III

Subs. of Res. No. 183 - 18 - 19. By Alderpersons Wolf and Donohue.
March 18, 2019.

A RESOLUTION dissolving the Sustainable Sheboygan Task Force.

WHEREAS, the Sustainable Sheboygan Task Force was established by way of Subs. of Res. No. 22-08-09, as amended by Res. No. 54-08-09 and Res. No. 181-16-17; and

WHEREAS, the purpose of the Sustainable Sheboygan Task Force was to study and make recommendations to the Common Council regarding strategies to be adopted by the City for creating and maintaining a sustainable Sheboygan, focusing on such topics as recycling, green purchasing, energy conservation, waste management and sustainability measures, and raising community awareness on environmental stewardship, that would result in cost savings and reduced consumption of resources throughout the City of Sheboygan; and

WHEREAS, recommendations presented by the Sustainable Sheboygan Task Force have been implemented in the respective City departments and the Sustainable Sheboygan Task Force has fulfilled its purpose.

NOW, THEREFORE, BE IT RESOLVED: That the Sustainable Sheboygan Task Force is hereby eliminated and abolished and the associated authorizing resolutions (Subs. of Res. No. 22-08-09, as amended by Res. No. 54-08-09 and Res. No. 181-16-17) are hereby repealed.

BE IT FURTHER RESOLVED: That nothing in this resolution shall prevent the City Administrator from creating a city department green team to serve the City's future sustainability efforts.

BE IT FURTHER RESOLVED: That the City Administrator shall report back to the Common Council at least annually regarding the City's sustainability efforts.

BE IT FURTHER RESOLVED: That this Resolution shall be in effect from and after its passage and as of April 16, 2019.

I HEREBY CERTIFY that the foregoing Resolution was duly passed by the Common Council of the City of Sheboygan, Wisconsin, on the _____ day of _____, 20____.

Dated _____ 20____. _____, City Clerk

Approved _____ 20____. _____, Mayor

III

5.5

Res. No. 183 - 18 - 19. By Alderpersons Wolf and Donohue. March 4, 2019.

A RESOLUTION dissolving the Sustainable Sheboygan Task Force.

WHEREAS, the Sustainable Sheboygan Task Force was established by way of Subs. of Res. No. 22-08-09, as amended by Res. No. 54-08-09 and Res. No. 181-16-17; and

WHEREAS, the purpose of the Sustainable Sheboygan Task Force was to study and make recommendations to the Common Council regarding strategies to be adopted by the City for creating and maintaining a sustainable Sheboygan, focusing on such topics as recycling, green purchasing, energy conservation, waste management and sustainability measures, and raising community awareness on environmental stewardship, that would result in cost savings and reduced consumption of resources throughout the City of Sheboygan; and

WHEREAS, recommendations presented by the Sustainable Sheboygan Task Force have been implemented in the respective City departments and the Sustainable Sheboygan Task Force has fulfilled its purpose.

NOW, THEREFORE, BE IT RESOLVED: That the Sustainable Sheboygan Task Force is hereby eliminated and abolished and the associated authorizing resolutions (Subs. of Res. No. 22-08-09, as amended by Res. No. 54-08-09 and Res. No. 181-16-17) are hereby repealed.

BE IT FURTHER RESOLVED: That nothing in this resolution shall prevent the City Administrator from creating a city department green team to serve the City's future sustainability efforts.

BE IT FURTHER RESOLVED: That this Resolution shall be in effect from and after its passage and as of April 16, 2019.

*YUP
approve subs*

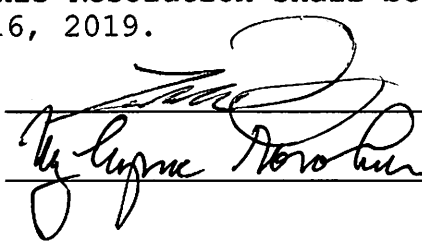

Eugene Donohue

I HEREBY CERTIFY that the foregoing Resolution was duly passed by the Common Council of the City of Sheboygan, Wisconsin, on the _____ day of _____, 20____.

Dated _____ 20____. _____, City Clerk

Approved _____ 20____. _____, Mayor

R. C. No. _____ - 18 - 19. By LICENSING, HEARINGS, AND PUBLIC SAFETY
COMMITTEE. March 18, 2019.

Your Committee to whom was referred Res. No. 184-18-19 by Alderpersons
Wolf and Donohue changing the starting time of the organizational meeting of
the new council for council year 2019-20; recommends approving the Substitute
Resolution.

Prep.

Committee

I HEREBY CERTIFY that the foregoing Committee Report was duly accepted
and adopted by the Common Council of the City of Sheboygan, Wisconsin, on the
_____ day of _____, 20____.

Dated _____ 20____, _____, City Clerk

Approved _____ 20____, _____, Mayor

III

Subs. of Res. No. 184 - 18 - 19. By Alderpersons Wolf and Donohue.
March 18, 2019.

A RESOLUTION changing the starting time of the organizational meeting of the new council for council year 2019-20.

WHEREAS, the organizational meeting of the new council for council year 2019-20 is scheduled to be held on April 16, 2019 (the third Tuesday of April) pursuant to Subsection 2-112(a)(2) of the Municipal Code; and

WHEREAS, council meetings are currently being held in the Sheboygan County Board Chambers at the Sheboygan County Courthouse during the remodeling of City Hall; and

WHEREAS, the County Board of Supervisors has a meeting scheduled for April 16, 2019 at 6:00 p.m. in the County Board Chambers.

NOW, THEREFORE, BE IT RESOLVED: That the organizational meeting of the new council for council year 2019-20 scheduled to be held on April 16, 2019, shall be held at 7:30 p.m. or ten (10) minutes after the conclusion of the Sheboygan County Board meeting, whichever is later.

I HEREBY CERTIFY that the foregoing Resolution was duly passed by the Common Council of the City of Sheboygan, Wisconsin, on the _____ day of _____, 20____.

Dated _____ 20____. _____, City Clerk

Approved _____ 20____. _____, Mayor

III

5.6

Res. No. 184 - 18 - 19. By Alderpersons Wolf and Donohue. March 4, 2019.

A RESOLUTION changing the starting time of the organizational meeting of the new council for council year 2019-20.

WHEREAS, the organizational meeting of the new council for council year 2019-20 is scheduled to be held on April 16, 2019 (the third Tuesday of April) pursuant to Subsection 2-112(a)(2) of the Municipal Code; and

WHEREAS, council meetings are currently being held in the Sheboygan County Board Chambers at the Sheboygan County Courthouse during the remodeling of City Hall; and

WHEREAS, the County Board of Supervisors has a meeting scheduled for April 16, 2019 at 6:00 p.m. in the County Board Chambers.

NOW, THEREFORE, BE IT RESOLVED: That the organizational meeting of the new council for council year 2019-20 scheduled to be held on April 16, 2019, shall be held at 7:30 p.m. or 20 minutes after the conclusion of the Sheboygan County Board meeting, whichever is later.

LHB
approve Subs

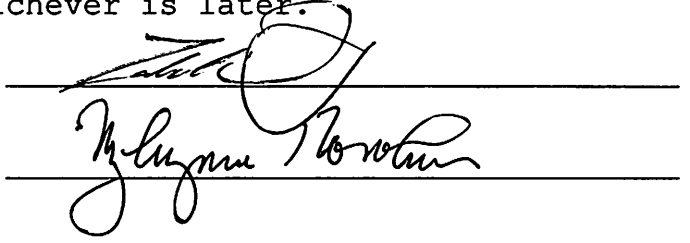

Suzanne Rowland

I HEREBY CERTIFY that the foregoing Resolution was duly passed by the Common Council of the City of Sheboygan, Wisconsin, on the _____ day of _____, 20____.

Dated _____ 20____, _____, City Clerk

Approved _____ 20____, _____, Mayor

~~X~~

Gen. Ord. No. _____ - 18 - 19. By Alderpersons Donohue, Sorenson, and Wolf.
March 18, 2019.

AN ORDINANCE amending Sections 58-31 and 58-33 of the Municipal Code to provide that the member of the library board appointed from the common council serve a one-year term.

THE COMMON COUNCIL OF THE CITY OF SHEBOYGAN DO ORDAIN AS FOLLOWS:

Section 1. Section 58-31 of the Sheboygan Municipal Code entitled "Composition" is amended so as to read as follows:

"Sec. 58-31. *Composition.*

The library board shall consist of nine appointed members who shall be citizens and residents of the city. One of the members of the board shall be the superintendent of the public school district of the city or the superintendent's representative to represent the public school district in which the public library is located. One of the members of the board shall be an alderperson."

Section 2. Section 58-33 of the Sheboygan Municipal Code entitled "Terms" is amended so as to read as follows:

"Sec. 58-33. *Terms.*

With the exception of the member appointed from the common council, each member of the library board shall serve as such for a term of three years, each term to commence on May 1 following the appointment. The aldermanic member shall serve for a term of one year, each term to commence on May 1 following the appointment. Should the alderperson appointed to the board no longer hold the position of alderperson, that position shall become vacant, and the mayor may, subject to confirmation by the council, appoint a new aldermanic member to fill the remaining term."

LHDS

Section 3. All ordinances or parts thereof in conflict with the provisions of this ordinance are hereby repealed to the extent of such conflict, and this ordinance shall be in effect upon the commencement of the 2019-2020 council year (April 16, 2019), and after its passage and publication.

I HEREBY CERTIFY that the foregoing Ordinance was duly passed by the Common Council of the City of Sheboygan, Wisconsin, on the _____ day of _____, 20____.

Dated _____ 20____. _____, City Clerk

Approved _____ 20____. _____, Mayor

~~X~~

Gen. Ord. No. - 18 - 19. By Alderpersons Wolf and Sorenson.
March 18, 2019.

AN ORDINANCE amending Section 18-15 of the Sheboygan Municipal Code to add a portion of Kiwanis Park as an area in which pets may be present when on a leash.

THE COMMON COUNCIL OF THE CITY OF SHEBOYGAN DO ORDAIN AS FOLLOWS:

Section 1. Section 18-15 of the Municipal Code entitled "Pets prohibited in parks and on public grounds except in designated areas; regulations" is hereby repealed and recreated in subsection (c)(1) thereof to read as follows:

"Sec. 18-15. Pets prohibited in parks and on public grounds except in designated areas; regulations.

. . .

(c) On-leash areas.

(1) Pets shall be allowed at the following locations: provided they are restrained by a substantial leash or chain not exceeding eight feet in length, or a retractable leash not exceeding 15 feet in length in the hands of a person directly controlling the movement of the animal:

. . .

g. Area 8 of Kiwanis Park when a Biergarten authorized by the Common Council is in operations (except during a festival in which all of Kiwanis Park has been rented, even if the Biergarten is in operations during that time)."

Public Works

Section 2. All ordinances or parts thereof in conflict with the provisions of this ordinance are hereby repealed to the extent of such conflict, and this ordinance shall be in effect from and after its passage and publication.

I HEREBY CERTIFY that the foregoing Ordinance was duly passed by the Common Council of the City of Sheboygan, Wisconsin, on the _____ day of _____, 20____.

Dated _____ 20____. _____, City Clerk

Approved _____ 20____. _____, Mayor

~~X~~

Gen. Ord. No. _____ - 18 - 19. By Alderpersons Wolf and Sorenson.
March 18, 2019.

AN ORDINANCE amending Section 74-57 of the Sheboygan Municipal Code with regard to locations in which the prohibition of glass beverage containers does not apply.

THE COMMON COUNCIL OF THE CITY OF SHEBOYGAN DO ORDAIN AS FOLLOWS:

Section 1. Section 74-57 of the Municipal Code entitled "Glass beverage containers" is hereby repealed and recreated in subsection (b) thereof to read as follows:

"Sec. 74-57. Glass beverage containers.

. . .

(b) This section shall not apply to the following:

. . .

(3) Persons possessing a cup, glass, bottle or other container made of glass designed or used for holding a beverage in Area 8 of Kiwanis Park for which a deposit has been paid to a Biergarten authorized by the Common Council.

(4) Where otherwise provided by approval of the director of engineering and public works for other organized functions."

Public works



Section 2. All ordinances or parts thereof in conflict with the provisions of this ordinance are hereby repealed to the extent of such conflict, and this ordinance shall be in effect from and after its passage and publication.

I HEREBY CERTIFY that the foregoing Ordinance was duly passed by the Common Council of the City of Sheboygan, Wisconsin, on the _____ day of _____, 20____.

Dated _____ 20____. _____, City Clerk

Approved _____ 20____. _____, Mayor

II

OTHER MATTERS

R. O. No. 234 - 18 - 19. By CITY CLERK. March 18, 2019.

Submitting various license applications for the period ending December 31, 2019, April 14, 2020 and June 30, 2020.

City Clerk

BEVERAGE OPERATOR'S LICENSE (NEW) (June 30, 2020)

<u>No.</u>	<u>Name</u>	<u>Address</u>
2639	Benzow, Donna L.	N18792 Ten Acre Road, Goodman
2624	Chambers, Stacey L.	204 Wisconsin Street, Sheboygan Falls
2632	Deering, Mitchell B.	1530A Georgia Avenue
2623	Hochrein, Rhiannon B.	4520 Mueller Road
2642	Joy, Katherine A.	730 S. 8 th Street
2335	Lopez, Glennie J.	1616 Superior Avenue
2643	Niemuth, Melissa A.	1005 Grand Avenue, Manitowoc
2625	Miller, Elizabeth E.	1320 N. 17 th Street
2635	Nativida, Negrete C.	927 Dillingham Avenue
2640	Pellowski, William M.	301 New York Avenue
2641	Pratt, Mary E.	1012 Falls Park Dr. #12, Sheboygan Falls
2626	Schleyhahn, Lucas J.	2617 N. 5 th Street
1297	Schmidt, Miranda R.	703 High Aveue #204
2631	Thomson, Kay E.	W7107 County Road U, Plymouth
2628	Yang, Mang	1526 Ontario Avenue

TAXICAB DRIVERS LICENSE (NEW) (December 31, 2019)

<u>No.</u>	<u>Name</u>	<u>Address</u>
2636	Moser, Michael P.	2201 Erie Avenue #C113
2629	Ortiz, Maria J.	909 Ontario Avenue #E17

Massage Establishment License (NEW) (December 31, 2019)

<u>No.</u>	<u>Name</u>	<u>Address</u>
1701	Salon Sase	631 Riverfront Drive

LHPS

Sidewalk Café License (Renew) (April 14, 2020)

<u>No.</u>	<u>Name</u>	<u>Address</u>
3129	Greece E Spoon	1217 N. 8 th Street
2427	Urbane	1231 N. 8 th Street
2604	Z Spot Espresso & Coffee	1024 Indiana Avenue

OTHER MATTERS

III

Res. No. 194 - 18 - 19. By Alderpersons Wolf and Sorenson.
March 18, 2019.

A RESOLUTION authorizing the Purchasing Agent to indicate the City's intent to obtain a new Vactor Truck in 2020.

WHEREAS, in 2015 the City of Sheboygan entered into a five-year operating lease for the lease/purchase of a heavy duty sanitary sewer maintenance vehicle known as a Vactor, which is used to keep sanitary sewer pipelines flowing freely and to clear the pipes when clogging is an issue; and

WHEREAS, the five-year lease ends in 2020, and includes a balloon payment that the City may use to purchase the vehicle or use as an offset to the cost of leasing a new vehicle; and

WHEREAS, given the long lead time associated with a Vactor, if the City wishes to take delivery of a new Vactor in 2020, it must indicate its desire to do so in 2019; and

WHEREAS, because the Vactor is a particularly complicated piece of equipment, in order to ensure the Vactor is available when it is needed, City staff recommends, and the Council agrees, that it is in the best interest of the City that the City obtain a new Vactor Truck in 2020 rather than purchase the vehicle it began using in 2015; and

WHEREAS, the Council desires to use an appropriate financing mechanism to fund the new Vactor Truck; and

WHEREAS, the Vactor is available from MacQueen Equipment, Inc. under the Sourcwell National Purchasing Organization and, therefore, competitive bidding is not required for the Vactor Truck itself.

NOW, THEREFORE, BE IT RESOLVED: That the Purchasing Agent is authorized to indicate to MacQueen Equipment, Inc. that the City's intent is to obtain a new Vactor Truck in 2020.

Public Works

BE IT FURTHER RESOLVED: That no expenditure of funds is authorized by this Resolution. In accordance with state law, any expenditure of funds, and any approval of an agreement regarding financing will be reviewed and, if acceptable, approved at a later time after the Council has been presented with a final version of the agreement.

I HEREBY CERTIFY that the foregoing Resolution was duly passed by the Common Council of the City of Sheboygan, Wisconsin, on the _____ day of _____, 20____.

Dated _____ 20____. _____, City Clerk

Approved _____ 20____. _____, Mayor