

*****ATTACHMENTS*****

CITY OF SHEBOYGAN
TWENTY-SECOND REGULAR COMMON COUNCIL MEETING

Monday, February 18, 2019

ALDERPERSONS PRESENT:

Todd Wolf, Mary Lynne Donohue, Jim Bohren, Ryan Sorenson, Ron Rindfleisch, Markus Savaglio, Dean Dekker, Rose Phillips, Trey Mitchell - 9.

ALDERPERSONS ABSENT AND EXCUSED:

Rosemarie Trester - 1.

Meeting called to order at 6:00 PM

1. OPENING OF MEETING

1.1 ROLL CALL

1.2 PLEDGE OF ALLEGIANCE

1.3 APPROVAL OF MINUTES

MOTION TO APPROVE MINUTES

Motion by Todd Wolf, second by Mary Lynne Donohue.

Final Resolution: Motion Passes

Aye: Todd Wolf, Mary Lynne Donohue, Jim Bohren, Ryan Sorenson, Ron Rindfleisch, Markus Savaglio, Dean Dekker, Rose Phillips, Trey Mitchell - 9.

1.4 RESIGNATION - Amanda Salazar from the Mead Public Library Board

MOTION TO ACCEPT AND FILE

Motion by Todd Wolf, second by Mary Lynne Donohue.

Final Resolution: Motion Passes

Aye: Todd Wolf, Mary Lynne Donohue, Jim Bohren, Ryan Sorenson, Ron Rindfleisch, Markus Savaglio, Dean Dekker, Rose Phillips, Trey Mitchell - 9.

1.5 RESIGNATION - Adam Cain from the Historic Preservation Commission

MOTION TO ACCEPT AND FILE

Motion by Todd Wolf, second by Mary Lynne Donohue.

Final Resolution: Motion Passes

Aye: Todd Wolf, Mary Lynne Donohue, Jim Bohren, Ryan Sorenson, Ron Rindfleisch, Markus Savaglio, Dean Dekker, Rose Phillips, Trey Mitchell - 9.

1.6 PRESENTATION - The Dark Store Loophole Property Tax Shift by Curt Witynski, J.D., Deputy Executive Director of the League of Wisconsin Municipalities

1.7 PUBLIC FORUM - Limit of five people having five minutes each with comments limited to items on this agenda. No one spoke.

1.8 MAYOR'S ANNOUNCEMENTS - UPCOMING COMMUNITY EVENTS, PROCLAMATIONS, EMPLOYEE RECOGNITIONS

2. CONSENT AGENDA

2.1 MOTION TO ACCEPT AND FILE ALL RO'S, ACCEPT AND ADOPT ALL RC'S AND PASS ALL RESOLUTIONS AND ORDINANCES

Resolution: MOTION TO ACCEPT AND FILE ALL RO'S, ACCEPT AND ADOPT ALL RC'S AND PASS ALL RESOLUTIONS AND ORDINANCES

MOTION TO ACCEPT AND FILE ALL RO'S, ACCEPT AND ADOPT ALL RC'S AND PASS ALL RESOLUTIONS AND ORDINANCES

Motion by Todd Wolf, second by Mary Lynne Donohue.

Final Resolution: Motion Passes

Aye: Todd Wolf, Mary Lynne Donohue, Jim Bohren, Ryan Sorenson, Ron Rindfleisch, Markus Savaglio, Dean Dekker, Rose Phillips, Trey Mitchell - 9.

2.2 R. O. No. 218-18-19 by City Clerk granting various license applications (Plymouth Landscape). ACCEPT AND FILE

Resolution: MOTION TO ACCEPT AND FILE

Motion by Todd Wolf, second by Mary Lynne Donohue.

Final Resolution: Motion Passes

Aye: Todd Wolf, Mary Lynne Donohue, Jim Bohren, Ryan Sorenson, Ron Rindfleisch, Markus Savaglio, Dean Dekker, Rose Phillips, Trey Mitchell - 9.

2.3 R. C. No. 249-18-19 by Licensing, Hearings, and Public Safety Committee to whom was referred R. O. No. 181-18-19 by City Clerk submitting various license applications; recommends granting the license. ACCEPT AND FILE

Resolution: MOTION TO ACCEPT AND FILE

Motion by Todd Wolf, second by Mary Lynne Donohue.

Final Resolution: Motion Passes

Aye: Todd Wolf, Mary Lynne Donohue, Jim Bohren, Ryan Sorenson, Ron Rindfleisch, Markus Savaglio, Dean Dekker, Rose Phillips, Trey Mitchell - 9.

2.4 R. C. No. 250-18-19 by Licensing, Hearings, and Public Safety Committee to whom was referred R. O. No. 216-18-19 by Fire Chief, pursuant to section 50-564 of the Municipal Code, submitting the quarterly report of Benchmark Measurements for the Fire Department, for the period commencing October 1, 2018 and ending December 31, 2018; recommends filing the document. ACCEPT AND FILE

Resolution: MOTION TO ACCEPT AND FILE

Motion by Todd Wolf, second by Mary Lynne Donohue.

Final Resolution: Motion Passes

Aye: Todd Wolf, Mary Lynne Donohue, Jim Bohren, Ryan Sorenson, Ron Rindfleisch, Markus Savaglio, Dean Dekker, Rose Phillips, Trey Mitchell - 9.

2.5 R. C. No. 251-18-19 by Licensing, Hearings, and Public Safety Committee to whom was referred R. O. No. 217-18-19 by City Clerk submitting various license applications; recommends granting the licenses. ACCEPT AND FILE

Resolution: MOTION TO ACCEPT AND FILE

Motion by Todd Wolf, second by Mary Lynne Donohue.

Final Resolution: Motion Passes

Aye: Todd Wolf, Mary Lynne Donohue, Jim Bohren, Ryan Sorenson, Ron Rindfleisch, Markus Savaglio, Dean Dekker, Rose Phillips, Trey Mitchell - 9.

2.6 R. C. No. 252-18-19 by Public Works Committee to whom was referred Res. No. 159-18-19 by Alderpersons Wolf and Sorenson authorizing the Director of Public Works to execute a Stormwater Facilities Maintenance Agreement between the City of Sheboygan and St. Nicholas Hospital of the

Hospital Sisters of the Third order of St. Francis regarding the Prevea St. Nicholas Medical Office Building project; recommends approving the Resolution. ACCEPT AND ADOPT AND PASS RESOLUTION

Resolution: MOTION TO ACCEPT AND ADOPT AND PASS RESOLUTION

Motion by Todd Wolf, second by Mary Lynne Donohue.

Final Resolution: Motion Passes

Aye: Todd Wolf, Mary Lynne Donohue, Jim Bohren, Ryan Sorenson, Ron Rindfleisch, Markus Savaglio, Dean Dekker, Rose Phillips, Trey Mitchell - 9.

2.7 R. C. No. 253-18-19 by Licensing, Hearings, and Public Safety Committee to whom was referred Res. No. 173-18-19 by Alderpersons Donohue and Sorenson authorizing the Purchasing Agent to issue a purchase order for the purchase of two new vehicles for the Sheboygan Fire Department; recommends approving the Resolution. ACCEPT AND ADOPT AND PASS RESOLUTION

Resolution: MOTION TO ACCEPT AND ADOPT AND PASS RESOLUTION

Motion by Todd Wolf, second by Mary Lynne Donohue.

Final Resolution: Motion Passes

Aye: Todd Wolf, Mary Lynne Donohue, Jim Bohren, Ryan Sorenson, Ron Rindfleisch, Markus Savaglio, Dean Dekker, Rose Phillips, Trey Mitchell - 9.

3. REPORTS OF OFFICERS

3.1 R. O. No. 219-18-19 by City Clerk submitting a claim from Progressive, on behalf of their insured driver (Phyllis Bathel) for alleged damages to her vehicle when it was struck by a City of Sheboygan vehicle. REFER TO FINANCE AND PERSONNEL COMMITTEE

3.2 R. O. No. 220-18-19 by City Administrator submitting the City of Sheboygan 2019 Long Term Financial Plan to the Common Council. REFER TO FINANCE AND PERSONNEL COMMITTEE

3.3 R. O. No. 221-18-19 by Chief of Police submitting the annual report of the Sheboygan Police Department for the year 2018. REFER TO LICENSING, HEARINGS, AND PUBLIC SAFETY COMMITTEE

4. RESOLUTIONS

4.1 Res. No. 175-18-19 by Alderpersons Wolf and Sorenson authorizing the appropriate City officials to enter into a contract for the Mead Public Library Plaza renovation project. REFER TO PUBLIC WORKS COMMITTEE

4.2 Res. No. 176-18-19 by Alderpersons Wolf and Sorenson authorizing a transfer of appropriations in the 2019 Budget (traffic signal upgrade). REFER TO PUBLIC WORKS COMMITTEE

5. REPORT OF COMMITTEES

5.1 R. C. No. 254-18-19 by Finance and Personnel Committee to whom was referred DIRECT REFERRAL Res. No. 174-18-19 by Alderpersons Rindfleisch and Bohren authorizing the appropriate City officials to enter into contracts with the UW Badger Band and the Stefanie H. Weill Center for the Performing Arts with regard to the performance of the UW Badger Band at the Weill Center as a fundraiser for the Mayor's International Committee on April 1, 2019; recommends approving Resolution with updated contract. ACCEPT AND ADOPT AND PASS RESOLUTION

MOTION TO ACCEPT AND ADOPT AND PASS RESOLUTION

Motion by Ron Rindfleisch, second by Jim Bohren.

Final Resolution: Motion Passes

Aye: Todd Wolf, Mary Lynne Donohue, Jim Bohren, Ryan Sorenson, Ron Rindfleisch, Markus

Savaglio, Dean Dekker, Rose Phillips, Trey Mitchell - 9.

5.2 R. C. No. 255-18-19 by Licensing, Hearings, and Public Safety Committee to whom was referred DIRECT REFERRAL Gen. Ord. No. 41-18-19 by Alderpersons Donohue and Sorenson amending Section 130-131 of the Municipal Code relating to commercial quadricycle hours of operation; recommends approving the Ordinance. ACCEPT AND ADOPT AND PASS ORDINANCE

MOTION TO ACCEPT AND ADOPT AND PASS ORDINANCE

Motion by Mary Lynne Donohue, second by Ryan Sorenson.

Final Resolution: Motion Passes

Aye: Todd Wolf, Mary Lynne Donohue, Jim Bohren, Ryan Sorenson, Ron Rindfleisch, Markus Savaglio, Dean Dekker, Rose Phillips, Trey Mitchell - 9.

6. GENERAL ORDINANCE

6.1 Gen. Ord. No. 42-18-19 by Alderpersons Rindfleisch and Bohren amending Section 82-33 of the Sheboygan Municipal Code so as to modify the City Administrator's Department Table of Organization. REFER TO FINANCE AND PERSONNEL COMMITTEE

6.2 Gen. Ord. No. 43-18-19 by Alderpersons Rindfleisch and Bohren amending Section 82-33 of the Sheboygan Municipal Code so as to modify the Senior Activity Center Table of Organization. REFER TO FINANCE AND PERSONNEL COMMITTEE

6.3 Gen. Ord. No. 44-18-19 by Alderpersons Rindfleisch and Bohren amending Section 82-33 of the Sheboygan Municipal Code so as to modify the City Development Department/Building Inspection Division Table of Organization. REFER TO FINANCE AND PERSONNEL COMMITTEE

6.4 Gen. Ord. No. 45-18-19 by Alderpersons Donohue, Dekker, Sorenson and Wolf amending Section 2-138 of the Municipal Code to provide that remote attendance would be included in the quorum count. REFER TO LICENSING, HEARINGS, AND PUBLIC SAFETY COMMITTEE

7. OTHER MATTERS RECEIVED AFTER THE AGENDA WAS PUBLISHED

7.1 RESIGNATION - Alderperson Rosemarie Trester from the City of Sheboygan Common Council - District 4.

7.2 R. O. No. 222-18-19 by the City Clerk submitting various license applications. REFER TO LICENSING, HEARINGS, AND PUBLIC SAFETY COMMITTEE

7.3 Gen. Ord. No. 46-18-19 by Alderpersons Rindfleisch and Bohren amending Section 82-33 of the Sheboygan Municipal Code so as to modify the Department of Finance Table of Organization. REFER TO FINANCE AND PERSONNEL COMMITTEE

8. CLOSED SESSION

8.1 Motion to convene in closed session under the exemption contained in Sec. 19.85(1)(e), Wis. Stats., where competitive or bargaining reasons require a closed session related to a development opportunity at the former Boat Doctors, 1320 Niagara Avenue.

MOTION TO CONVENE IN CLOSED SESSION

Motion by Todd Wolf, second by Mary Lynne Donohue.

Final Resolution: Motion Passes

Aye: Todd Wolf, Mary Lynne Donohue, Jim Bohren, Ryan Sorenson, Ron Rindfleisch, Markus Savaglio, Dean Dekker, Rose Phillips, Trey Mitchell - 9.

9. ADJOURN MEETING

9.1 Motion to Adjourn

MOTION TO ADJOURN at 7:17 PM

Motion by Todd Wolf, second by Mary Lynne Donohue.

Final Resolution: Motion Passes

Aye: Todd Wolf, Mary Lynne Donohue, Jim Bohren, Ryan Sorenson, Ron Rindfleisch, Markus Savaglio, Dean Dekker, Rose Phillips, Trey Mitchell - 9.

Generated by Melissa Clevenger on Tuesday, February 19, 2019

February 18, 2019

Resignation

Alderperson Rosemarie Trester submitting her resignation from the City of Sheboygan Common Council - District 4.

Drop
over

DeBruin, Meredith

From: Alderperson Rosemarie Trester
Sent: Monday, February 18, 2019 6:16 AM
To: Mayor Vandersteen
Cc: DeBruin, Meredith; Alderperson Todd Wolf
Subject: Resignation

Mayor Mike Vandersteen
City Hall
Sheboygan, Wisconsin 53081

Rosemarie Trester
2110 N. 9th Street
Sheboygan, Wisconsin 53081

February 17, 2019

Dear Mayor Vandersteen,

It is with sadness that I have to write this to you. I am going to have to resign from City Council because of health issues. I have enjoyed being a part of council and I have learned a lot from all of you.

Thank you for the experience and the opportunity to serve. Wishing you all the best.

Respectfully,

Rosemarie Trester

Hard copy coming.

Mayor Mike Vandersteen
City Hall
Sheboygan, Wisconsin 53081

Rosemarie Trester
2110 N. 9th Street
Sheboygan, Wisconsin 53081

February 17, 2019

Dear Mayor Vandersteen,

It is with sadness that I have to write this to you. I am going to have to resign from City Council because of health issues. I have enjoyed being a part of council and I have learned a lot from all of you.

Thank you for the experience and the opportunity to serve. Wishing you all the best.

Respectfully,

A handwritten signature in cursive script that reads "Rosemarie Trester".

Rosemarie Trester



February 28, 2019

HONORABLE MEMBERS OF THE COMMON COUNCIL:

I hereby submit the following appointment for your consideration:

Paul Gottsacker to be considered for appointment to the Historic Preservation Commission to fill the unexpired term of Adam Cain whose term expires 4/20/2020.

MICHAEL J. VANDERSTEEN, MAYOR

OFFICE OF MAYOR

CITY HALL
828 CENTER AVE., SUITE 301
SHEBOYGAN, WI
53081-4495

920/459-3317
FAX 920/459-0256



February 28, 2019

HONORABLE MEMBERS OF THE COMMON COUNCIL:

I hereby submit the following appointment for your consideration:

Vicky Schneider to be considered for appointment to the position of Director of Senior Services.

MICHAEL J. VANDERSTEEN, MAYOR

OFFICE OF MAYOR

CITY HALL
828 CENTER AVE., SUITE 301
SHEBOYGAN, WI
53081-4495

920/459-3317
FAX 920/459-0256



2019 State of the City

Mission Statement

The City of Sheboygan is dedicated to providing residents, the business community and visitors with fiscally-responsible municipal services in an effective and responsive manner to meet the needs of our diverse community.

Vision Statement

The City of Sheboygan will be a family oriented and prosperous community with a wide variety of housing, business, cultural and recreational opportunities in safe and attractive neighborhoods.

Strategic Plan Focus Areas

- 1. Quality of Life**
- 2. Infrastructure and Public Facilities**
- 3. Economic Development**
- 4. Neighborhood Revitalization**
- 5. Governing and Fiscal Management**
- 6. Communication**

Quality of Life

Providing a safe and secure community investing in recreation, libraries, open spaces maximizing the natural environment delivering transportation choices, elevating culture, arts and education ensuring sustainable and environmentally responsible solutions.

Quality of Life

Increased guardianship in neighborhoods helps maintain low crime rates.

Part 1 crime rate - property crimes

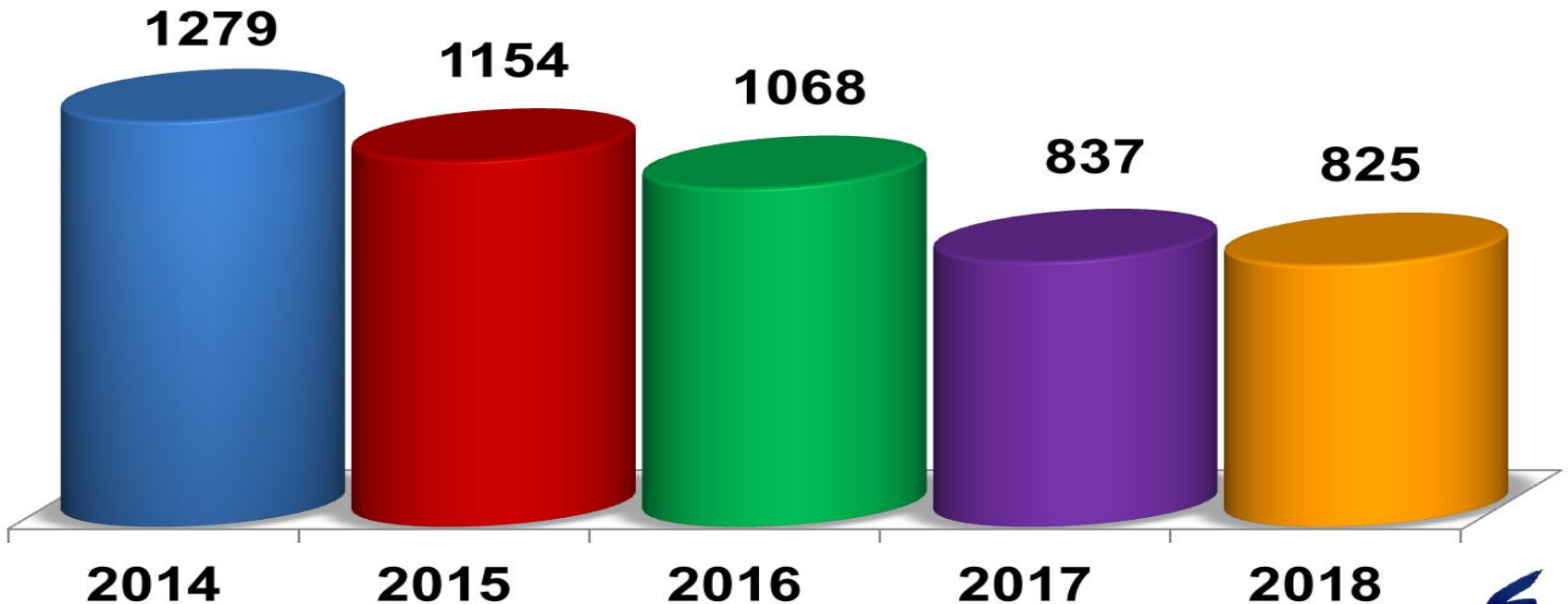

Quality of Life

Increased guardianship in neighborhoods helps maintain low crime rates.

Part 1 crime rates - violent crimes

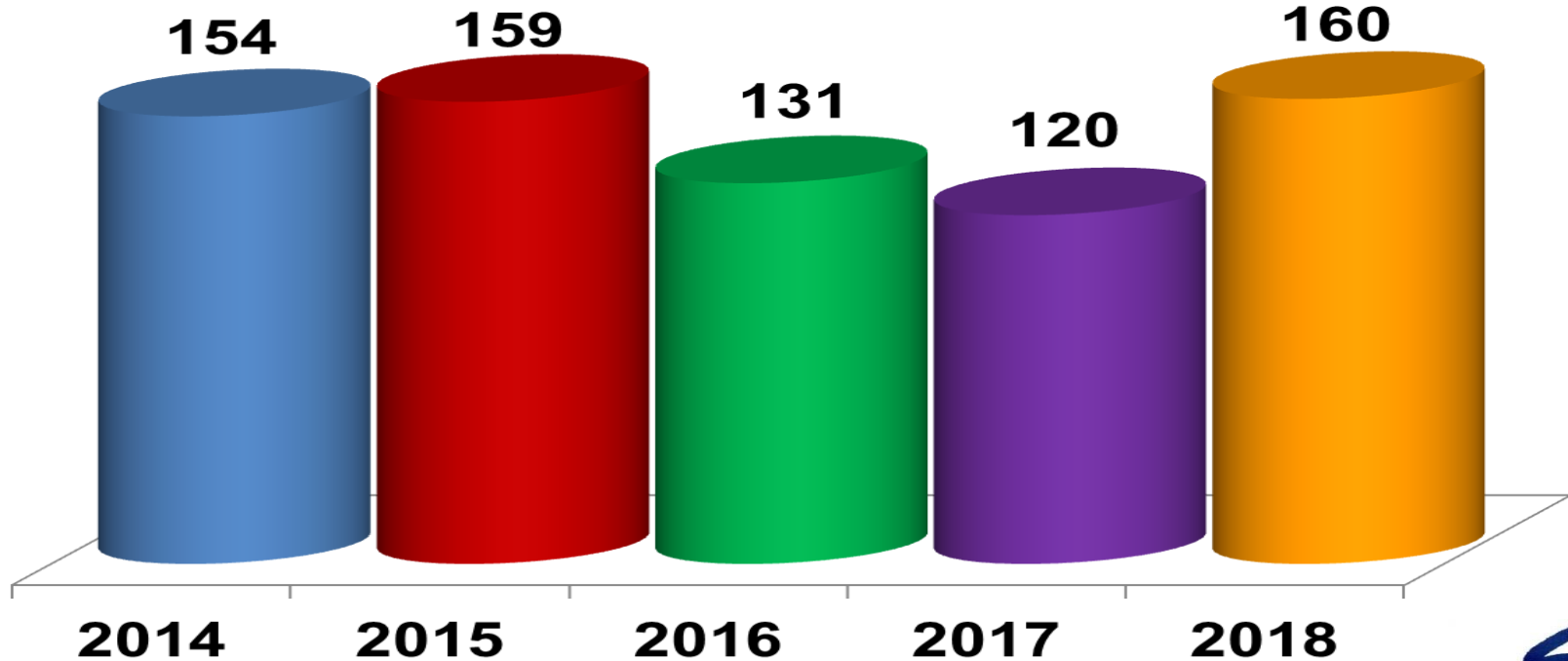

Infrastructure and Public Facilities

FAMILY PUT HER IN THE SPARTA
ORPHANAGE. "TEMPORARILY." A FURNITURE
BARON ADOPTED HER. SHE WAS RAISED
IN THE UPPER ECHELONS OF SHEBOYGAN
COUNTRY.

**Improving the quality of life by effectively
developing, maintaining and improving
infrastructure, natural resources and
community services.**

IS FOR CHAIR

Infrastructure and Public Facilities

Construct, repair and maintain city streets to ensure public safety and commerce.

- **7.2 miles of streets improved in 2018**
- **308% increase in street improvements since 2014**

Miles of Street Improvement

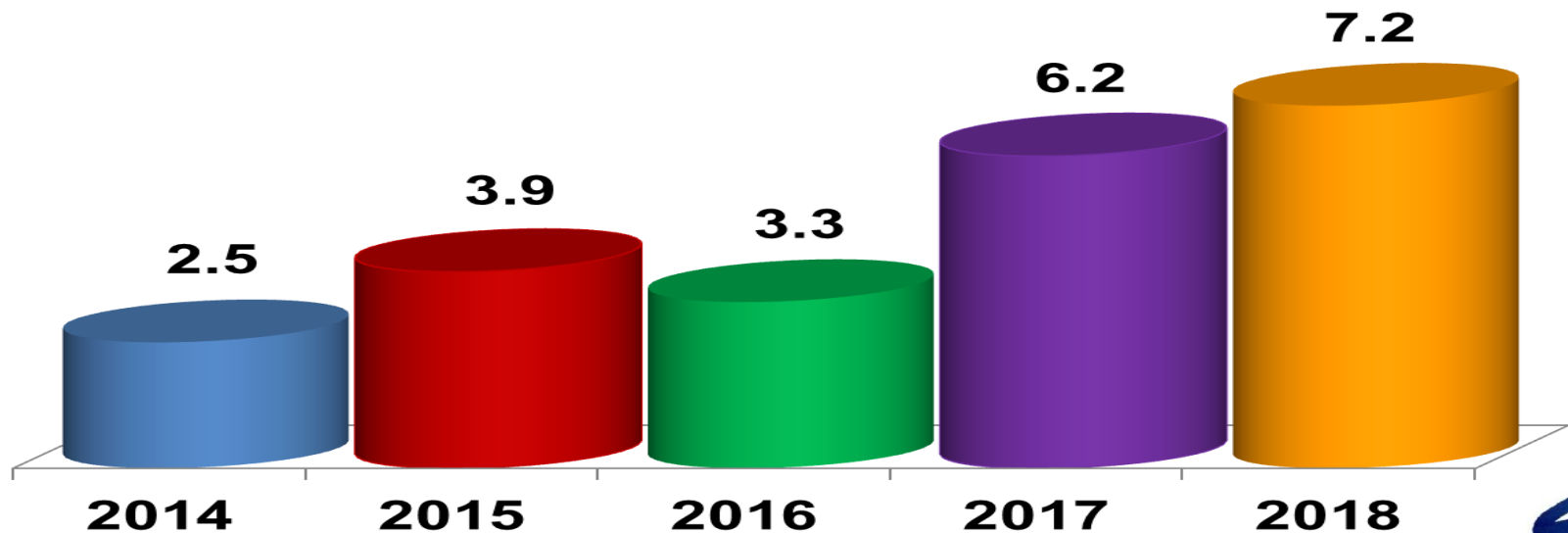

Infrastructure and Public Facilities

Construct, repair and maintain city streets to ensure public safety and commerce.

- **PASER (Pavement Surface and Evaluation Rating).**
- **Rating increased 5% in 2017 due to substantial street improvements.**
- **Rating valid for 2 years. Revaluation occurs in 2019.**

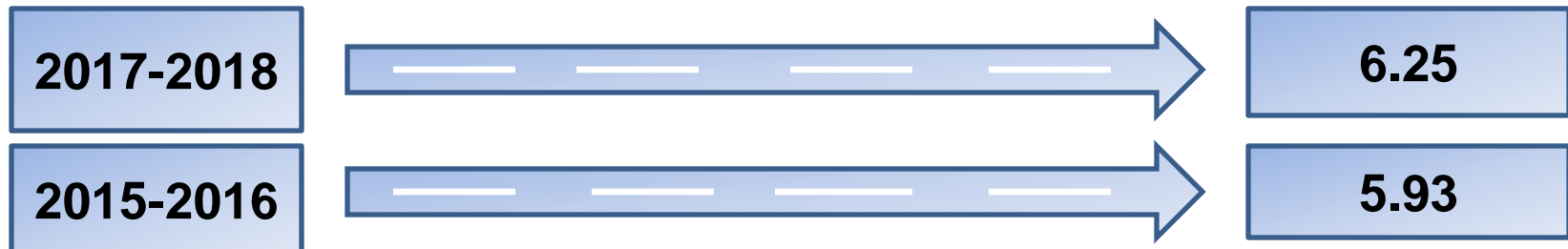

Infrastructure and Public Facilities

**Commence City Hall renovation project –
\$10.5 million.**



2019 State of the City



Economic Development

Actively pursuing economic and business development strategies to support a growing and sustainable economic base, ensuring the financial resources needed to improve the quality of life, fund services and provide a diversity of job opportunities for city residents.



CITY OF SHEBOYGAN
SouthPointe
ENTERPRISE CAMPUS

CONTRACTOR PIS Contractors, Inc.	ENGINEER Ruecker & Mielke, Inc.
SUBCONTRACTORS Relyco, Inc.	JT Engineering, Inc.
Vinton Construction Co.	GEOTECHNICAL Terracon Consultants, Inc.
D.E. Thome Electric	PLANNING
All-Ways Contractors	

2019 State of the City



Economic Development

Residential property values

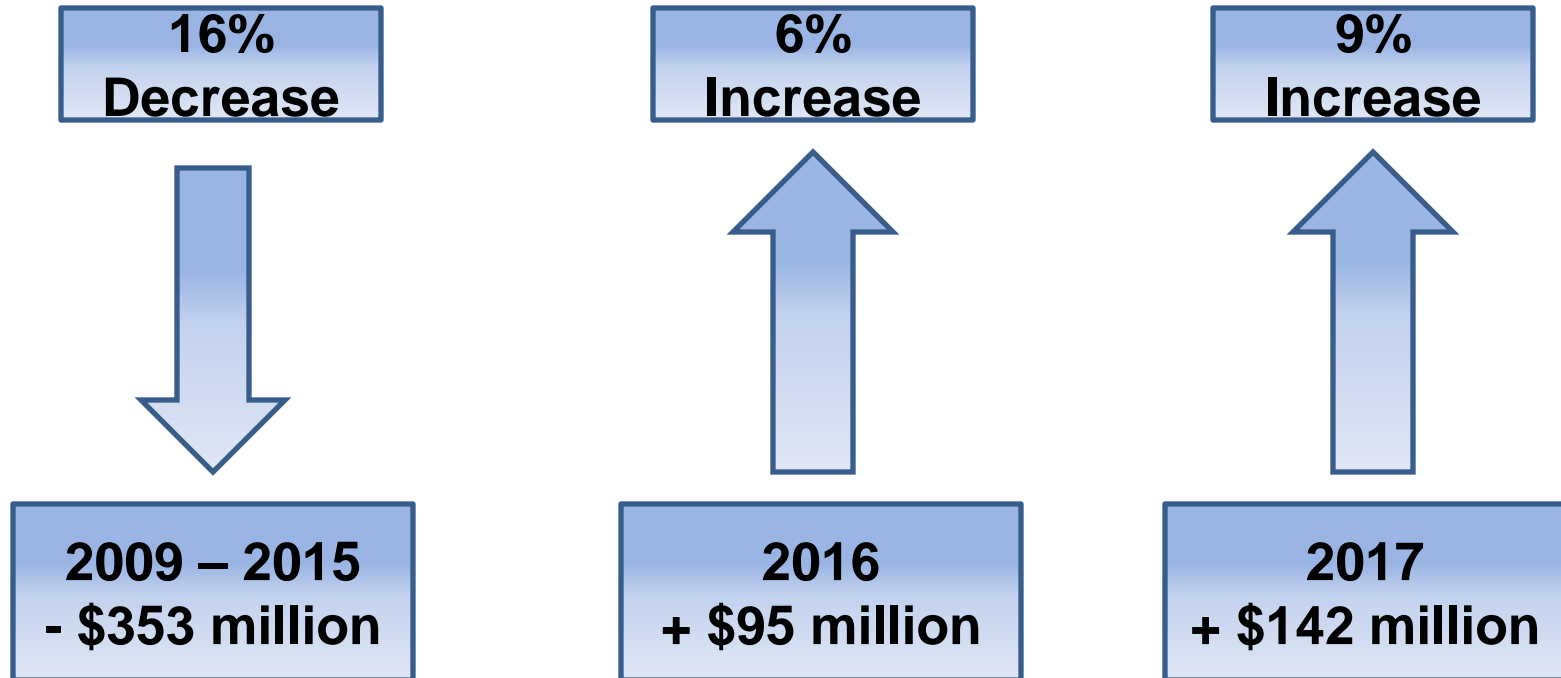

Economic Development

Three new Economic Development initiatives:



TID 17

- Redevelop Indiana Avenue corridor
- Creation of Fresh Tech Innovation District



TID 18

- Creation of SouthPointe Enterprise Campus
- 160 acre business center adjacent to I-43



TID 19

- Redevelop west side of Sheboygan River
- South of Erie Avenue

Economic Development

TID valuation increased 20% since 2014 (values in millions).

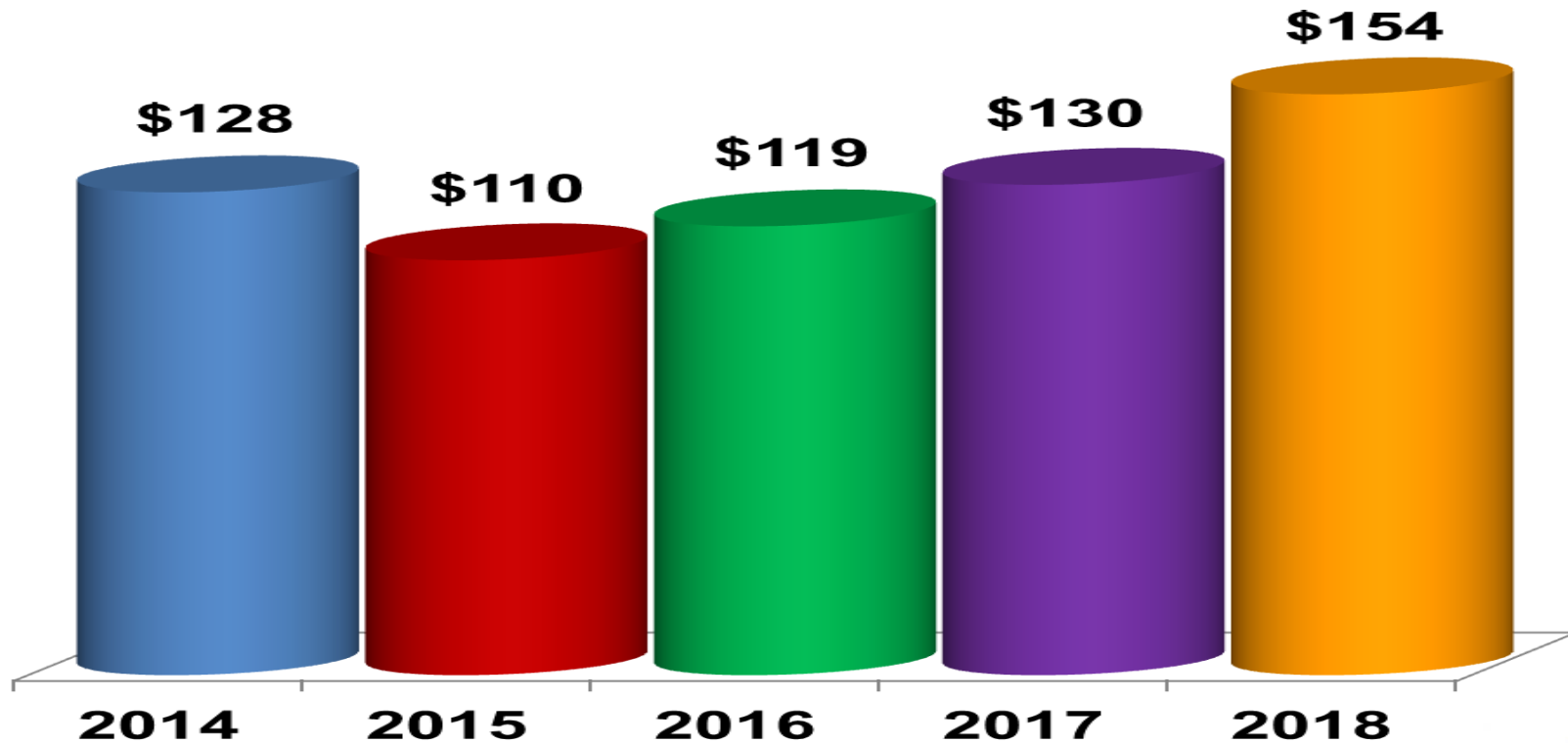

Neighborhood Revitalization

Encouraging reinvestment in the city's housing stock, creating solid neighborhoods with strong leadership, ensuring quality new housing developments, creating new diverse and affordable options for all citizens.

Neighborhood Revitalization

Neighborhood associations provide strength and unity in our community:



2013 – Creation of the first; Historic Gateway Neighborhood



2018 – Additional 3 neighborhoods added



2018 – 9 total neighborhood associations

2019 State of the City

Neighborhood Revitalization

Concerted efforts to focus resources on strengthening and improving neighborhood include:

- **Organized 2 Rock-the-Block collaborative rehabilitation events targeting both North and South side neighborhoods in 2018.**
- **Secured grant funding to support 2 neighborhood beat officers.**



Neighborhood Revitalization

Concerted efforts to focus resources on strengthening and improving neighborhoods include:

- **Enforcement of housing code violations.**



Governing and Fiscal Management

Implementing innovative and responsible policies and business practices to effectively manage its fiscal and human resources and maintaining an outstanding quality of life for our citizens.

Governing and Fiscal Management

Improving transparency and awareness of financial information empowers residents to become active participants in city government.



Distinguished Budget Presentation award - GFOA



Certificate of Distinction in Performance Measurement - ICMA



Transparency and Benchmarking Center – powered by ClearGov™

Governing and Fiscal Management

Uncommitted General Fund Balance by dollar amount and percent of expenditures:

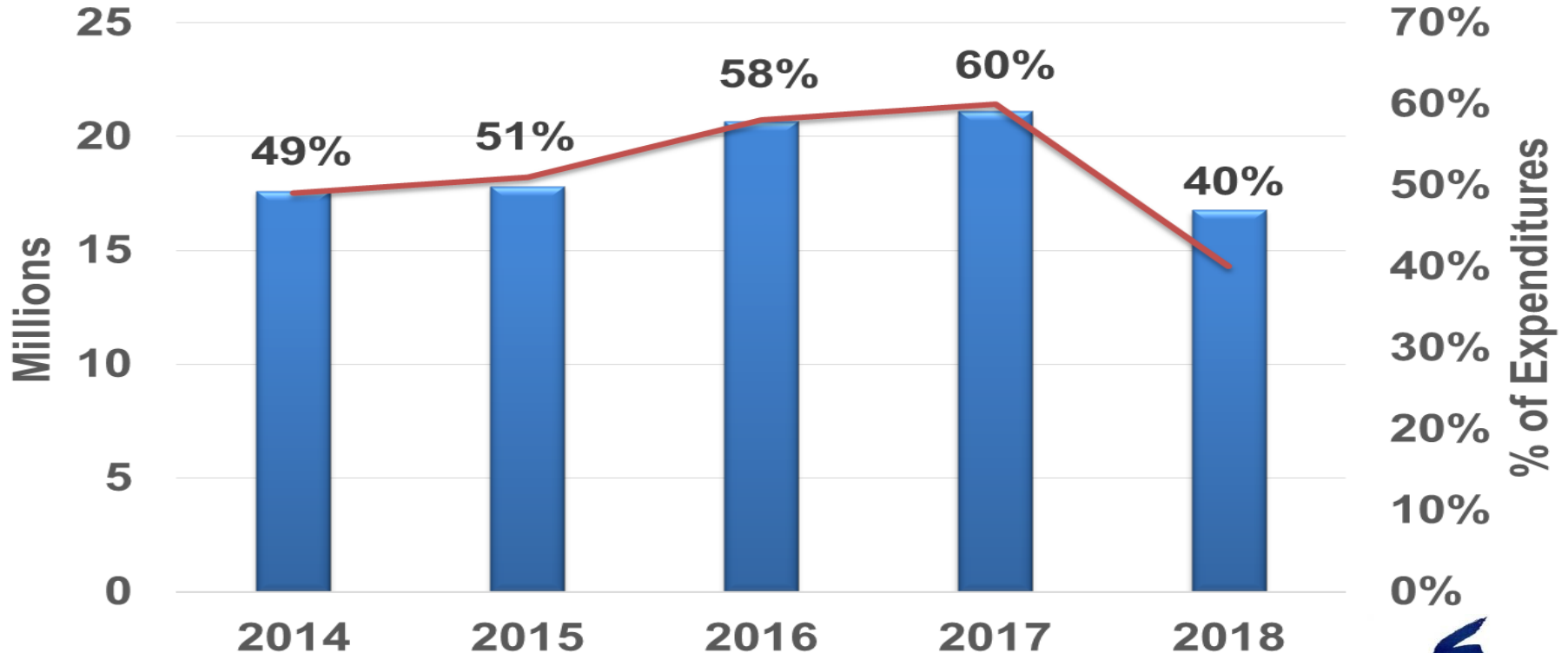

Governing and Fiscal Management

GO Debt Management

Statutory Limit / Policy / Net GO Debt Outstanding

as of 12/31/2018

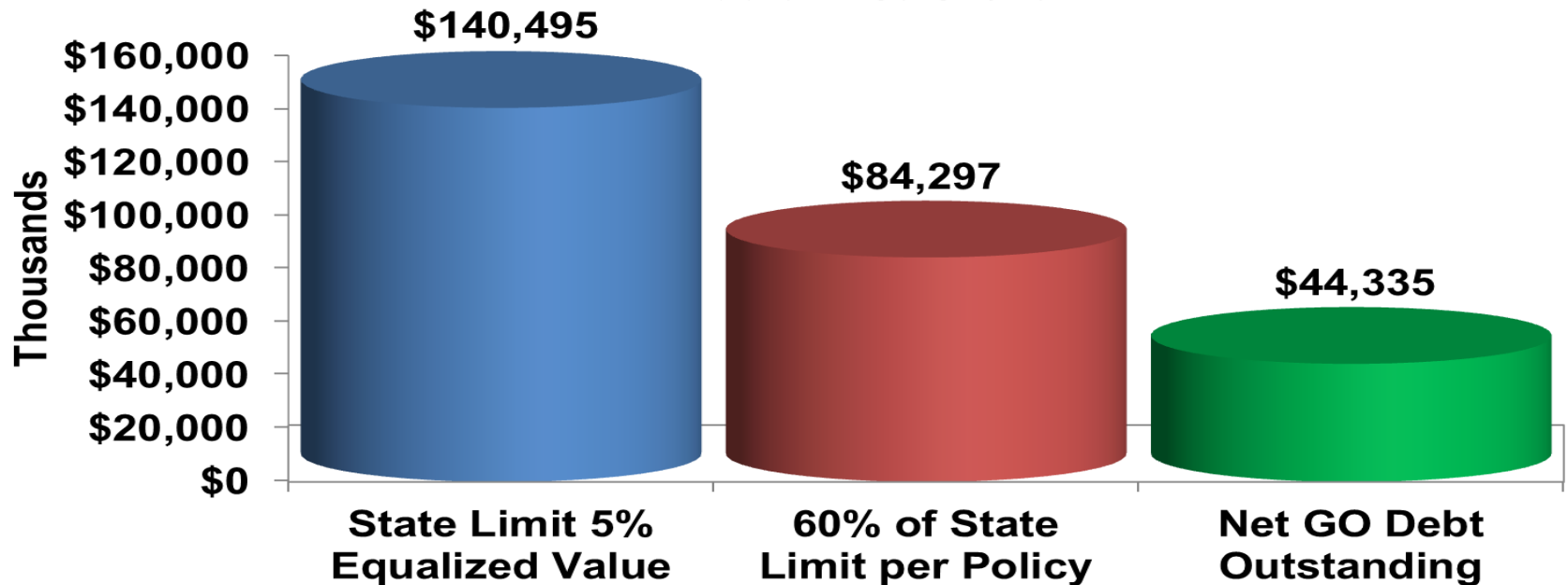

Governing and Fiscal Management

Moody's Bond rating for Sheboygan remains strong at Aa2.

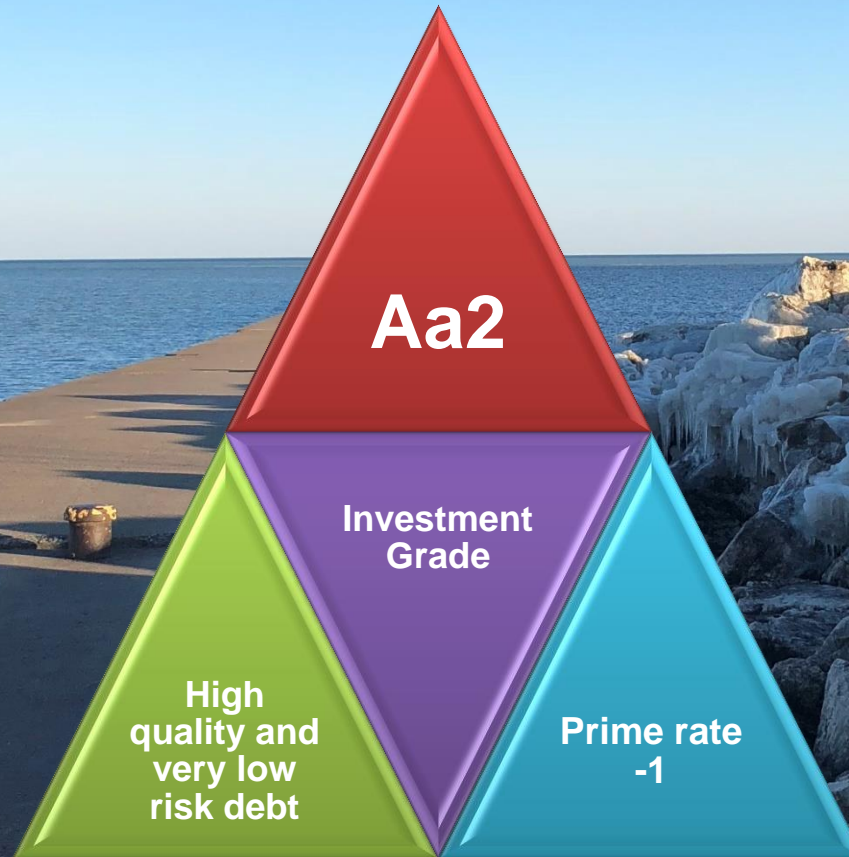

Communication

Ensuring effective and consistent communication activities with residents, businesses and visitors using new technologies, innovative approaches and brand identity to ensure transparency and encourage dialog among residents and government agencies.

Communication

Common Council and city staff are collaboratively taking a proactive approach to improving resident participation and transparency:

- **Sheboygan Insider Monthly e-newsletter, Transparency and Benchmarking Center powered by ClearGov™ and Annual Community Survey**



Communication

Our electronic and social media presence expanded substantially over the last year.



**Facebook
users = 16,259
122% increase**



**Twitter
followers =
9,329
118% growth**



**Nextdoor.com
users = 4,286
117% gain**



**Nixle users =
2,005
120% advance**



Hearing No. - 18 - 19. March 4, 2019.

Pursuant to a notice published and personal notices sent by the City Clerk, there is a hearing scheduled for this evening for the proposed assessments for water lateral replacement in North Avenue from N. 15th Street to N. 21st Street.

Any interested persons may be heard.



February 14, 2019

Ms. Meredith DeBruin
City Clerk
City of Sheboygan
Sheboygan, WI 53081

Dear Meredith:

The Sheboygan Water Utility hereby requests that you cause notice to be published no later than Wednesday, February 20, 2019, schedule public hearing(s), and introduce final resolution(s) requesting confirmation of **WATER LATERAL replacement** special assessments, in conjunction with the Common Council's **March 4, 2019** meeting, *for the following water lateral replacement project(s):*

<u>Location</u>	<u>Prel. Res. #</u>
North Avenue from N. 15 th St. to N. 21 st St.	

Open review period: **February 20, 2019 to March 4, 2019**, 7:30 AM to 4:00 PM daily, excluding Saturdays, Sundays & holidays, at the Water Utility office, 72 Park Ave. Contact phone numbers: 459-3839 or 459-3806.

*If you have any questions or concerns, please inform us as soon as possible, so that we can coordinate the **processing of notices** to property owners for the above listed project(s). City Finance is being given this information simultaneously for the preparation of notices required by Statute.*

Sincerely,

Rich Dale
Distribution Supervisor
SHEBOYGAN WATER UTILITY

Publish - Wednesday, February 20, 2019
CLASSIFIEDS PLEASE

OFFICIAL NOTICE

NOTICE IS HEREBY GIVEN that the Board of Water Commissioners of the City of Sheboygan filed with me a report of special assessments for water lateral replacements in the following street:

North Avenue from N. 15th Street to N. 21st Street

PUBLIC NOTICE is hereby given, that special assessments have been made according to law, and the same will be open for review and correction by the said Board of Water Commissioners at the office of the Water Utility, 72 Park Avenue from February 20, 2019 to March 4, 2019, between the hours of 7:30 A.M. and 4:00 P.M. daily, excluding Saturdays, Sundays and Holidays. Contact phone numbers: 459-3839 or 459-3806.

FURTHER NOTICE is hereby given that the Common Council of the aforesaid City will, at a regular meeting to be held on the 4th day of March, 2019, at 6:00 P.M., consider the said reports and hear all objections which may be made thereto, and will determine what portion of the cost of the improvement, if any, shall be paid by the City.

MEREDITH DEBRUIN
City Clerk

Preliminary Schedule of Special Assessments for: Water Lateral Replacement

Project/Street Name: North Avenue - N. 15th Street to N. 21st St

Page 1 of 1

Prelim. Res. #: _____

Date Passed: _____

Publish By: TJT

Requested Hearing Date: _____

Utility Opening Date: _____

Closing Date: _____

Assessment Rate for 1", per LF: \$105.00

DNR Rate: _____

Service Address	Assessment Number	New Service Size	Estimated Footage Main to Curb Stop (lin ft)	Estimated Assessment Cost to Property Owner	Estimated Footage Curb Stop to Meter (lin ft)	Estimated Cost to DNR Funds
2636 N. 15th St	626620	1"	19	\$1,995.00	25	\$0.00
1509 North Ave	626610	1"	16	\$1,680.00	26	\$0.00
1511 North Ave	626600	1"	16	\$1,680.00	27	\$0.00
1515 North Ave	626590	1"	9	\$945.00	100	\$0.00
1523 North Ave	626580	1"	7	\$735.00	36	\$0.00
1527 North Ave	626570	1"	7	\$735.00	35	\$0.00
1537 North Ave	626560	1"	7	\$735.00	29	\$0.00
1541 North Ave	626550	1"	6	\$630.00	0	\$0.00
1545 North Ave	626540	1"	7	\$735.00	30	\$0.00
1603 North Ave	626530	1"	7	\$735.00	31	\$0.00
1607 North Ave	626520	1"	7	\$735.00	25	\$0.00
1615 North Ave	626510	1"	7	\$735.00	23	\$0.00
1619 North Ave	626500	1"	7	\$735.00	30	\$0.00
1623 North Ave	626490	1"	7	\$735.00	30	\$0.00
1629 North Ave	626480	1"	7	\$735.00	30	\$0.00
1635 North Ave	626470	1"	7	\$735.00	30	\$0.00
1639 North Ave	626460	1"	7	\$735.00	30	\$0.00
1643 North Ave	626450	1"	7	\$735.00	30	\$0.00
1645 North Ave	626440	1"	7	\$735.00	30	\$0.00
1703 North Ave	626430	1"	8	\$840.00	0	\$0.00
PAGE TOTALS:			172	\$18,060.00	597	\$0.00

M 19-01

FORM SPA020W 02/18/19
THE FOLLOWING IS A SCHEDULE OF LOTS, PARTS OF LOTS, AND
PARCELS OF LAND FRONTING ON NORTH AVE
FROM N 15TH ST TO N 21ST ST
IN THE 04 WARD OF THE CITY OF SHEBOYGAN.

PRELIMINARY ESTIMATE FOR WATER LATERALS
SHEBOYGAN WISCONSIN

PAGE
PROJ. NUMBER 01

CONTRACTOR
INSPECTOR

CONTRACT DATE 00/00/00
RESOLUTION NO. 1721819
PASSED 02/04/19

THIS WORK OR IMPROVEMENT CONSTITUTES AN EXERCISE OF POLICE POWER AND THE PROPERTY AGAINST WHICH ASSESSMENT IS PROPOSED IS BENEFITED

OWNER AND DESCRIPTION OF PROPERTY	FRONTAGE	DEDUCTION	ADJUSTED FRONTAGE	SIZE OF LATERAL	COST PER FT	TOTAL COST	RECEIPT NUMBER	DATE PAID	INSTALLED/ POSTPONED
626430 STONE, DENNIS A 1703 NORTH AVE SCHUBERTS SUBD LOTS 25, 26 & THE W 40' OF LOT 27	8.00		8.00	01	105.00	840.00			
626440 SCHILLING, KENNETH 1645 NORTH AVE SCHUBERTS SUBD E 20' OF LOT 27 & W 20' OF LOT 28	7.00		7.00	01	105.00	735.00			
626450 VAN DE WEGHE, STEPHANIE 1643 NORTH AVE SCHUBERTS SUBD E 40' OF LOT 28	7.00		7.00	01	105.00	735.00			
626460 YANG, MEE 1639 NORTH AVE SCHUBERTS SUBD W 45' OF LOT 29	7.00		7.00	01	105.00	735.00			
626470 SIENKIEWICZ, PATRICIA H 1635 NORTH AVE SCHUBERTS SUBD E 15' OF LOT 29 & W 30' OF LOT 30	7.00		7.00	01	105.00	735.00			
626480 TREE OF LIFE PROPERTIES, LLC 1629 NORTH AVE SCHUBERTS SUBD E 30' OF LOT 30 & W 15' OF LOT 31	7.00		7.00	01	105.00	735.00			
626490 BUTZEN, MARK S 1623 NORTH AVE SCHUBERTS SUBD E 45' OF LOT 31	7.00		7.00	01	105.00	735.00			
626500 WILLIAMS, CARRIE S 1619 NORTH AVE	7.00		7.00	01	105.00	735.00			

FORM SPA020D 02/18/19
 THE FOLLOWING IS A SCHEDULE OF LOTS, PARTS OF LOTS, AND
 PARCELS OF LAND FRONTING ON
 FROM TO
 IN THE CITY OF SHEBOYGAN.

FINAL ESTIMATE FOR STORM SEWER,
 SANITARY SEWER, & WATER LATERALS

PAGE
 PROJ. NUMBER

CONTRACTOR

RESOLUTION NO.
 PASSED

THIS WORK OR IMPROVEMENT CONSTITUTES AN EXERCISE OF POLICE POWER AND THE PROPERTY AGAINST WHICH ASSESSMENT IS PROPOSED IS BENEFITED

OWNER AND DESCRIPTION OF PROPERTY	STORM SEWER LINEAL FT.	COST	SANITARY SEWER LINEAL FT.	COST	WATER LATERALS LINEAL FT.	COST	TOTAL COST	DATE PAID	ENTERED ON TAXROLL
SCHUBERTS SUBD LOT 32									
626510 VAN GROOTHEEST, JOHN L 1615 NORTH AVE SCHUBERTS SUBD LOT 33	7.00		7.00	01	105.00	735.00			
626520 VAN DYKE, LARRY M 1607 NORTH AVE SCHUBERTS SUBD W 45' OF LOT 34	7.00		7.00	01	105.00	735.00			
626530 ZACHARI TRUST 1603 NORTH AVE SCHUBERTS SUBD E 15' OF LOT 34 & W 30' OF LOT 35	7.00		7.00	01	105.00	735.00			
626540 HANSEN, SHAWN R 1545 NORTH AVE SCHUBERTS SUBD W 14.5' OF LOT 36 & E 30' OF LOT 35	7.00		7.00	01	105.00	735.00			
626550 HABITAT FOR HUMANITY LAKESIDE INC NORTH AVE SCHUBERTS SUBD E 45.5' OF LOT 36	6.00		6.00	01	105.00	630.00			
626560 BONELLI, JOSEPH P 1537 NORTH AVE SCHUBERTS SUBD W 20' OF LOT 38 & ALL OF LOT 37	7.00		7.00	01	105.00	735.00			
626570 DEKANICH, NICOLE M 1527 NORTH AVE SCHUBERTS SUBD E 40' OF LOT 38 & W 5' OF LOT 39	7.00		7.00	01	105.00	735.00			
626580 WAGNER, JAMES N	7.00		7.00	01	105.00	735.00			

FORM SPA020D 02/18/19
 THE FOLLOWING IS A SCHEDULE OF LOTS, PARTS OF LOTS, AND
 PARCELS OF LAND FRONTING ON
 FROM TO
 IN THE CITY OF SHEBOYGAN.

FINAL ESTIMATE FOR STORM SEWER,
 SANITARY SEWER, & WATER LATERALS

PAGE
 PROJ. NUMBER

CONTRACTOR

RESOLUTION NO.
 PASSED

THIS WORK OR IMPROVEMENT CONSTITUTES AN EXERCISE OF POLICE POWER AND THE PROPERTY AGAINST WHICH ASSESSMENT IS PROPOSED IS BENEFITED

OWNER AND DESCRIPTION OF PROPERTY	STORM SEWER LINEAL FT.	COST	SANITARY SEWER LINEAL FT.	COST	WATER LATERALS LINEAL FT.	COST	TOTAL COST	DATE PAID	ENTERED ON TAXROLL
1523 NORTH AVE SCHUBERTS SUBD E 55' OF LOT 39									
626590 STEVENS, TIMOTHY 1515 NORTH AVE SCHUBERTS SUBD LOT 40 (EXCEPT PART TAKEN FOR STREET)	9.00		9.00	01	105.00	945.00			
626600 MOORE TRUST 1-13-06 1511 NORTH AVE SCHUBERTS SUBD W 40' OF LOT 41 EXC PRT TAKEN FOR ST & W 40' OF LOT 42 EXC S 8' THEREOF	16.00		16.00	01	105.00	1680.00			
626610 ACCURATE REPAIRS ACQUISITION LLC 1509 NORTH AVE SCHUBERTS SUBD E 100' OF LOT 41 EXC S 8' THEREOF & EXC PRT TAKEN FOR WIDENING OF NORTH AVE	16.00		16.00	01	105.00	1680.00			
626620 CUPP, SCOTT E 2636 N. 15TH ST. SCHUBERTS SUBD E 100' OF S 8' OF LOT 41 & E 100' OF N 56 1/4' OF LOT 42	19.00		19.00	01	105.00	1995.00			
TOTALS	172.00	.00	172.00			18060.00			

FORM SPA025B DATE OF RUN: 02/18/19 PRELIMINARY ESTIMATE FOR LATERALS-WATER

THE FOLLOWING ARE THE PROPERTY OWNER ADDRESSES FOR: NORTH AVE
FROM: N 15TH ST
TO: N 21ST ST

626430 STONE, DENNIS A		1703 NORTH AVE
1703 NORTH AVE SHEBOYGAN	WI 53083	
626440 SCHILLING, KENNETH		1645 NORTH AVE
503 CHURCH ST KOHLER	WI 53044	
626450 VAN DE WEGHE, STEPHANIE		1643 NORTH AVE
1643 NORTH AVE SHEBOYGAN	WI 53083	
626460 YANG, MEE		1639 NORTH AVE
1639 NORTH AVE SHEBOYGAN	WI 53083	
626470 SIENKIEWICZ, PATRICIA H		1635 NORTH AVE
1635 NORTH AVE SHEBOYGAN	WI 53083	
626480 TREE OF LIFE PROPERTIES, LLC		1629 NORTH AVE
PO BOX 42 SHEBOYGAN	WI 53082	
626490 BUTZEN, MARK S		1623 NORTH AVE
1623 NORTH AVE SHEBOYGAN	WI 53083	
626500 WILLIAMS, CARRIE S		1619 NORTH AVE
1619 NORTH AVE SHEBOYGAN	WI 53083	

FORM SPA025B DATE OF RUN: 02/18/19 PRELIMINARY ESTIMATE FOR LATERALS-WATER

THE FOLLOWING ARE THE PROPERTY OWNER ADDRESSES FOR: NORTH AVE
FROM: N 15TH ST
TO: N 21ST ST

626510 VAN GROOTHEEST, JOHN L		1615 NORTH AVE
1615 NORTH AVE SHEBOYGAN	WI 53083	
626520 VAN DYKE, LARRY M		1607 NORTH AVE
1607 NORTH AVE SHEBOYGAN	WI 53083	
626530 ZACHARI TRUST MARIA K ZACHARI 319 ELM ST SHEBOYGAN FLS	WI 53085	1603 NORTH AVE
626540 HANSEN, SHAWN R		1545 NORTH AVE
N4656 STATE ROAD 32 SHEBOYGAN FLS	WI 53085	
626550 HABITAT FOR HUMANITY LAKESIDE INC		NORTH AVE
PO BOX 973 SHEBOYGAN	WI 53082	
626560 BONELLI, JOSEPH P		1537 NORTH AVE
315 HURON AVE SHEBOYGAN	WI 53081	
626570 DEKANICH, NICOLE M		1527 NORTH AVE
1527 NORTH AVE SHEBOYGAN	WI 53083	
626580 WAGNER, JAMES N		1523 NORTH AVE
1523 NORTH AVE SHEBOYGAN	WI 53083	

FORM SPA025B DATE OF RUN: 02/18/19 PRELIMINARY ESTIMATE FOR LATERALS-WATER

THE FOLLOWING ARE THE PROPERTY OWNER ADDRESSES FOR: NORTH AVE
FROM: N 15TH ST
TO: N 21ST ST

626590 STEVENS, TIMOTHY		1515 NORTH AVE
1515 NORTH AVE SHEBOYGAN	WI 53083	
626600 MOORE TRUST 1-13-06		1511 NORTH AVE
N8163 SNAKE RD ELKHART LAKE	WI 53020	
626610 ACCURATE REPAIRS ACQUISITION LLC		1509 NORTH AVE
N4688 STEVEN ST SHEBOYGAN FLS	WI 53085	
626620 CUPP, SCOTT E		2636 N. 15TH ST.
2636 N. 15TH ST. SHEBOYGAN	WI 53083	

II

R. O. No. 223 - 18 - 19. By CITY CLERK. March 4, 2019.

Submitting various license applications.

City Clerk

TEMPORARY CLASS "B" LICENSE

<u>No.</u>	<u>Name</u>	<u>Address</u>
1497	D'werdenfelser Schuhplattler Club	148 South Road, Kohler - One day event to be held 05/11/19 at St. Dominics gymnasium - 2133 N. 27 th Street to include beer and wine.
2970	Elizabeth Ann Seaton School	814 Superior Avenue - One day event to be held 03/16/19 to include beer and wine.
2547	Friends of the Senior Center	428 Wisconsin Avenue - One day event to be held 04/25/19 to include beer and wine.
2547	Friends of the Senior Center	428 Wisconsin Avenue - One day event to be held 06/13/19 to include beer and wine.
3236	Sheboygan County Home Builders	637 Walton Drive, Plymouth - Three Day event to be held 03/22/19-03/24/19 at Lakers Ice Center - 1202 S. Wildwood Ave.
1377	St. Dominics Church	2133 N. 22 nd Street - One day event to be held 03/09/19 to include beer and wine.
2488	St. John's UCC	1248 Lincoln Avenue - One day event to be held 04/28/19 to include beer and wine.

Consent

TEMPORARY BEVERAGE OPERATOR'S LICENSE

No. Name

Address

0676 Gasper, Gene C.

3228 W. Apache Road

III

Res. No. _____ - 18 - 19. By Alderperson Rindfleisch. March 4, 2019.

A RESOLUTION confirming the exercise of police power in making an assessment for those benefited properties against which assessments are proposed for the replacement of lead and/or galvanized iron water laterals in North Avenue from N. 15th Street to N. 21st Street.

RESOLVED: That the assessments and schedule of the proposed assessments prepared by the Board of Water Commissioners for the proposed replacement of lead and/or galvanized iron water laterals in North Avenue from N. 15th Street to N. 21st Street are hereby confirmed, and the City Clerk is authorized and directed to publish the notices required by law.

BE IT FURTHER RESOLVED: That the Board of Water Commissioners is hereby authorized and directed to carry out the work in accordance with the report, as finally approved, and that payment thereof be made as therein provided.

Consent

I HEREBY CERTIFY that the foregoing Resolution was duly passed by the Common Council of the City of Sheboygan, Wisconsin, on the _____ day of _____, 20____.

Dated _____ 20____. _____, City Clerk

Approved _____ 20____. _____, Mayor

~~VI~~

R. C. No. _____ - 18 - 19. By LICENSING, HEARINGS, AND PUBLIC SAFETY
COMMITTEE. March 4, 2019.

Your Committee to whom was referred R. O. No. 204-18-19 by City Clerk submitting various license applications; recommends denying Taxicab Driver License application No. 2008 (Bethany B. Garcia) based upon her recent record of violations related to the licensed activity and her failure to cooperate with the committee.

Consent

_____ Committee

I HEREBY CERTIFY that the foregoing Committee Report was duly accepted and adopted by the Common Council of the City of Sheboygan, Wisconsin, on the _____ day of _____, 20____.

Dated _____ 20____. _____, City Clerk

Approved _____ 20____. _____, Mayor

II

Open Matters

7.1

R. O. No. 204 - 18 - 19. By CITY CLERK. January 7, 2019.

Submitting various license applications for the period ending June 30, 2019, December 31, 2019, and June 30, 2020.

City Clerk

CLASS "B" LIQUOR LICENSE (June 30, 2019) (NEW)

<u>No.</u>	<u>Name</u>	<u>Address</u>
3373	Union Tap Bar	1401 Union Avenue

BEVERAGE OPERATOR'S LICENSE (NEW) (June 30, 2020)

<u>No.</u>	<u>Name</u>	<u>Address</u>
2564	Bachmann, Robert P.	N8168 Dairyland Drive
2552	Dewitt, Morgan C.	2010 S. 13 th Street
2550	Duley, Hailey L.	2109 N. 10 th Street
2559	Fretwell, Jennifer D.	1716 S. 7 th Street
2553	Gideon, Calvin D.	1328 N. 9 th Street
2556	Kloppenburger, Ryan A.	1021 N. 6 th Street Apt. 3
1447	Schmidt, Nicholas M.	4819 S. 13 th Street
2566	Srock, Ryan L.	25 South Street, Plymouth
6350	Steinberg, Scott L.	1013 Humboldt Avenue
1533	Vandenberg, Brenda L.	3919 Mendocino Lane #206

TAXICAB DRIVERS LICENSE (RENEW) (December 31, 2019)

<u>No.</u>	<u>Name</u>	<u>Address</u>
2419	Bock, Nadine R.	1028 Broadway Avenue
1049	Chavez, Moises Jr.	2407 N. 10 th Street
2008	Garcia, Bethany B.	929 N. 8 th Street
0952	Pineda, Berta	4415 Primrose Court Apt. R202

TAXICAB DRIVERS LICENSE (NEW) (December 31, 2019)

<u>No.</u>	<u>Name</u>	<u>Address</u>
2549	Pettye, Terrance L.	1824 N. 7 th Street #1A

OHPS
1-16-19
Hold # 2008(Garcia)
2-27-19
#2008(Garcia) Denied

MESSAGE ESTABLISHMENT (Renew) (December 31, 2019)

<u>No.</u>	<u>Name</u>	<u>Address</u>
3252	Fantoli Massage & Wellness	4027 S. Business Drive
3232	Simply Altruistic Massage	604 Erie Avenue
2871	Hands In Motion	4027 S. Business Drive

VI

R. C. No. _____ - 18 - 19. By FINANCE AND PERSONNEL COMMITTEE.
March 4, 2019.

Your Committee to whom was referred R. O. No. 220-18-19 by City Administrator submitting the City of Sheboygan 2019 Long Term Financial Plan to the Common Council; recommends to file the document.

Consent

_____ Committee

I HEREBY CERTIFY that the foregoing Committee Report was duly accepted and adopted by the Common Council of the City of Sheboygan, Wisconsin, on the _____ day of _____, 20____.

Dated _____ 20____. _____, City Clerk

Approved _____ 20____. _____, Mayor

II

3.2

R. O. No. 220 - 18 - 19. By CITY ADMINISTRATOR. February 18, 2019.

Submitting the City of Sheboygan 2019 Long Term Financial Plan to the Common Council.

Finance
Personnel
ac file

City Administrator

LONG TERM FINANCIAL PLAN

The LTFP is a financial strategic plan

The City of Sheboygan, at the Common Council direction, annually prepares a comprehensive Long Term Financial Plan (LTFP), consistent with the City's Strategic Plan focus area of Governing and Fiscal Management. The LTFP is intended to serve as a tool, providing Common Council and the public with the insight required to address issues impacting the city's financial condition.

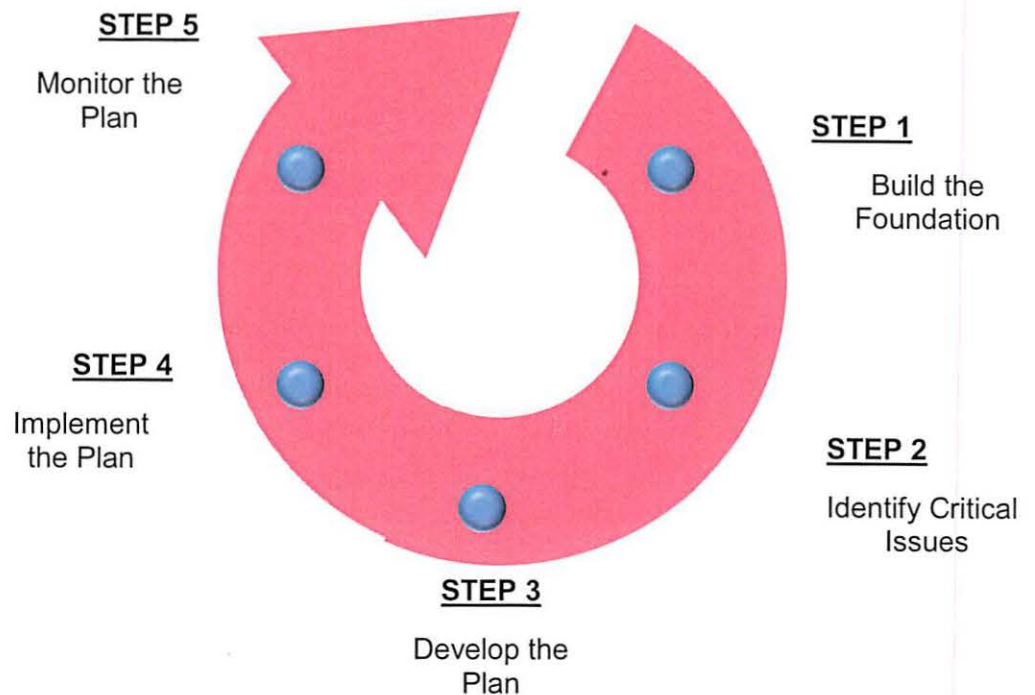

Long Term Financial Plan Process

The city's LTFP begins by identifying several critical areas which have, or are expected to have, an impact on the financial condition of the city over the next five years. Once the critical issues are identified, specific goals and objectives are developed for each project designed to meet the overall goal of the project.

The Long Term Financial Plan process

To provide a clear and concise Long Term Financial Plan, identifying the city's current and projected financial condition, and proposing specific alternatives to address identified problems.

The chart below graphically describes the process that went into developing the city's LTFP. This project was conducted largely by city management team.

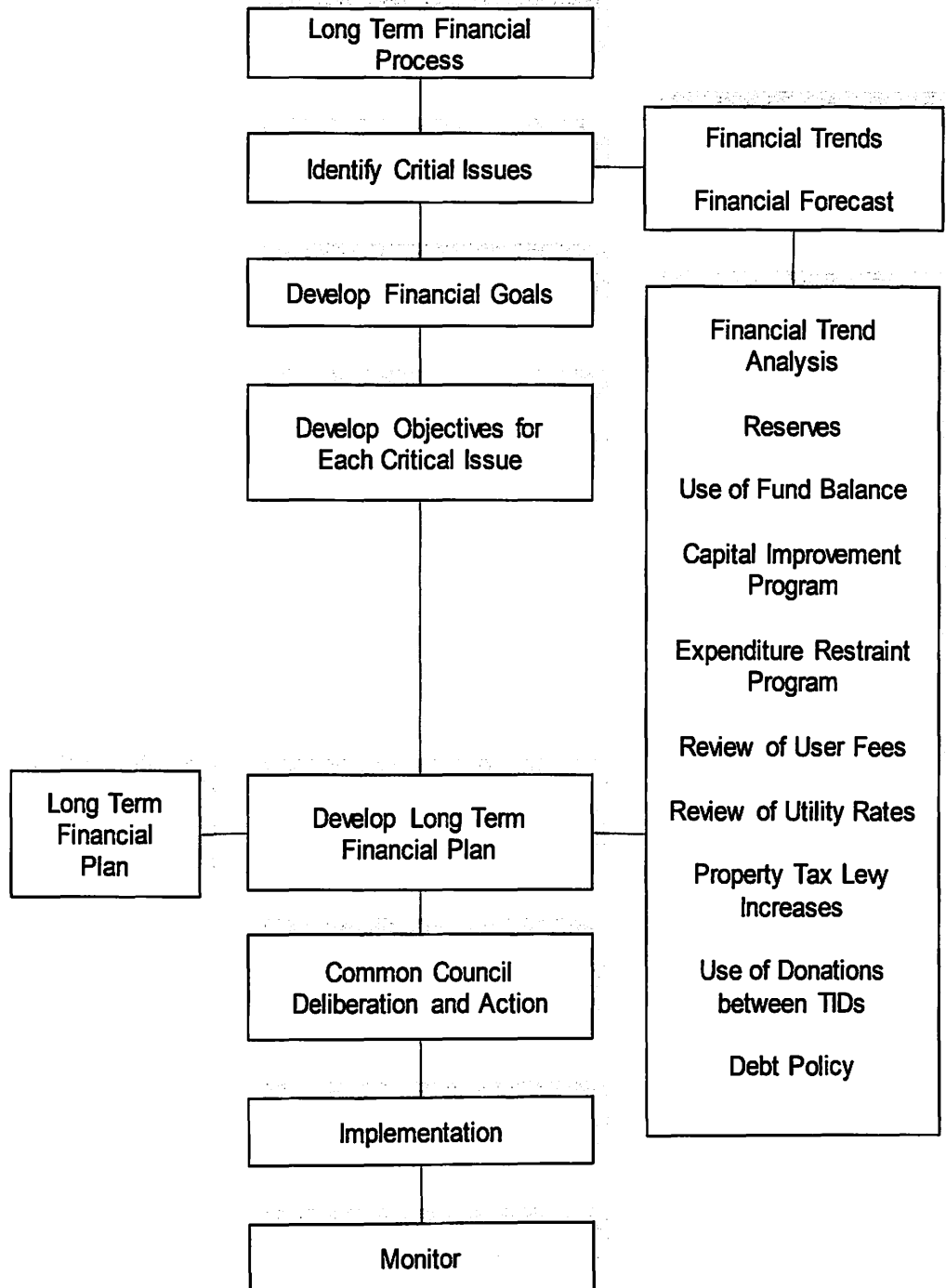

The Management Team is responsible for keeping the projects on track and on schedule. The Team also identifies when their goals and objections are met. The key message expressed to the Management Team is that the LTFP has to be clear and concise while providing very specific and practical recommendations that addressed the issue at hand.

The LTFP is presented in detail to the Common Council. The Finance and Personnel Committee will review the initial proposal in February, 2019. Following is the schedule that will be followed by the Common Council as they develop or update an action plan that the city will implement as a part of the upcoming budget process:

Schedule

February or March: LTFP provided to the Finance and Personnel Committee.

March or April: Public input and Common Council adoption

The LTFP represents elements of the City's fiscal policy.

The LTFP for the City of Sheboygan represents the ongoing commitment to implement its Strategic Plan focus area of Governing and Fiscal Management. LTFP have been incorporated on an annual basis into the development, deliberation and approval of the Annual Program Budget. The plan is intended to be a well thought-out analysis of the issues that may affect the finances of the City of Sheboygan.

Trends & Forecast are the foundation of the LTFP

The LTFP uses financial trends and forecasts to identify future financial challenges and opportunities, and then identifies strategies to secure financial sustainability within these same challenges and opportunities. The trends and forecast must identify how, from a financial perspective, the city will provide a consistent level of public services and also addresses special issues of concern to the community.

Financial Sustainability

Financial sustainability extends beyond the ability to raise sufficient revenue to meet expenditures by ensuring that the level and types of service expected from the community can be delivered while assessing and managing associated risk at acceptable levels of sources of revenue.

The goal is to ensure financial sustainability through flexibility, efficiency, sufficiency, integration and credibility.

Flexibility: ability to effectively respond to changing circumstances. The capacity to be able to respond to significant atypical conditions or events needs to be considered as part of this goal.

Efficiency: using public funds to provide the highest level of needed services possible within the funding available. There are two components of this goal: strive to use the least resources to provide a given level of service and to target resources at those services most valued by citizens and only providing services that provide sufficient value to justify the costs.

Funding sufficiency: having sufficient resources to support the delivery of services. This goal not only refers to the amount of funding but also to the consistency in funding level changes relative to changes in expenditures and the diversity of funding sources.

Integration: ensuring that the financial constraints under which the city operates are fully considered when engaged in policy-making and decision-making.

Credibility: achieving financial performance in a way that maintains public confidence in the city's ability to provide services and infrastructure at expected levels. Financial decisions should be consistent with the overall goal of financial sustainability. Services must be valuable to citizens and the benefits provided must be perceived that the services are in proportion to the taxes and fees paid.

Financial Strategies

Financial strategies have been identified to contribute to the five financial goals.

Ensure adequate funding: obtain adequate funding from multiple sources for requirements related to day-to-day operating commitments, capital equipment life cycle and infrastructure needs, as well as managing growth and development. This would encompass a balanced approach between understanding the timing and nature of operating expenditures to ensure they are matched with reliable and stable funding sources and capital funding related to infrastructure needs and maintaining capital assets. This strategy includes identifying costs and maintaining or increasing funding from existing and new revenue sources.

Achieving diverse sources of funding: identify actions related to alternative and innovative funding sources that will help the city respond to the pressures of growth and redevelopment and reduce the reliance on property taxes. Property taxes, user fees and intergovernmental revenue are the traditional inelastic revenue sources used to meet

expenditure requirements that are continually under upward pressure which can place stress on the city's financial position.

Managing expenditures: containing costs in order to limit pressure on revenue requirements maintain market competitiveness and/or reserve capacity to maintain service levels. This can be accomplished by increasing efficiencies in service delivery, setting spending priorities to ensure the most important areas are funded, and positioning the city as an efficient provider of services and infrastructure.

Providing for contingencies: prepare the city to manage risk and to be resilient when dealing with unforeseen circumstances while limiting the impact on services. This can be accomplished by monitoring economic and operational factors and forecasts in order to be able to respond to changing circumstances and ensuring that the city has access to enough funds to meet unforeseen urgent needs and manage risk appropriately.

Using debt strategically: providing capital funding flexibility by allowing infrastructure to be built and used before sufficient revenue has accumulated to offset needed investment. This can be accomplished by managing the level of debt and strategically making essential assets available as well as examining a wider range of debt financing instruments.

Operating with foresight: taking into account the current and future impacts of decisions on services and infrastructure. This includes maintaining or extending existing practices regarding a long-term approach in decision making.

Maintaining sufficient cash flow: allowing the city to pay the costs of supplying services and infrastructure throughout the year to match expenditure requirements, including debt service.

Promoting and enabling integration of priorities and resources: identifying and encouraging awareness of the financial implications of policy making and decision making on the city's financial position. This can be accomplished by linking needs and actions to resources, responsibilities and timeliness among stakeholders, promoting greater efficiency by reducing duplication of effort or working at cross purposes and managing growth and development.

***Input from Multi-Year
City Plans***

Common Council-approved multi-year Capital Improvements Program is included in the Long Term Financial Plan as it will impact the finances of the city over the next five years.

**State of Wisconsin
restrictions on local
governments**

From a fiscal perspective, the city's financial picture is positive. The General Fund's fund balance exceeds the city's policy of a minimum 25 percent of expenditures, largely due to significant expenditure savings experienced over the last few years.

Due to the Common Council's 2018 decision to utilize \$5.5 million of General Fund uncommitted fund balance to reduce the amount of borrowed funds for the \$10.5 million City Hall Renovation Project, the percent of uncommitted fund balance will decrease from 60 percent to 40 percent of expenditures.

Overall, the City is in excellent financial shape and should be able to accommodate the expenditure growth that is anticipated over the next ten years.

External factors imposed by the State of Wisconsin have played a key role in shaping the city's financial picture. These factors include restrictions on property tax levy increases and restrictions on new or increase in existing user fees without corresponding reductions in property tax level.

Several city funds are tied directly to development and consequently, are expanding. The active Tax Incremental Districts all have a positive financial outlook, as the increment is sufficient to meet obligations, or serve to donate funds to other districts. The city also has capacity to develop additional tax incremental districts within the 12 percent capacity limit established by the WI Department of Revenue.

The LTFP provides a framework from which the Common Council and Staff can frame future financial decisions.

As outlined in the 2019 Annual Program Budget the recommendations from the city's multi-year plans are included in the LTFP as they impact the finances of the city. All of the plans were utilized in LTFP analysis of the General Fund, tax levy and TID's. The fiscal related issues include:

- *Financial Trend Analysis* - All operating position and debt indicators were favorable.
- *Reserves* - The General Fund target is maintaining a minimum of 25 percent uncommitted fund balance. The LTFP indicates that a 25 percent uncommitted fund balance is attainable through the ten year period.
- *Use of Fund Balance as a revenue source* – The city policy restricts the amount of undesignated fund balance for the General Fund that is applied to the budget for the

- ensuing year shall not reduce the undesignated fund balance below an amount equal to 25 percent of the ensuing year's General Fund expenditures.
- *Capital Improvements Program* – The Five Year Capital Improvements Program includes requests from all city departments for assets and infrastructure improvements, including tax increment districts. The Five Year Capital Improvements Program is funded from tax levy, debt issuance, contributions and federal, state and local grant funding.
 - *Expenditure Restraint Program* – The analysis presumes the city will remain eligible for this State of Wisconsin program which rewards operating (funds affected by the tax levy) budgets who budget annually at or below inflation plus a percentage of net new construction. The LTFP projects expenditures based on projected inflation.
 - *Review of User Fees* – The city's Management Team reviews existing fees for consideration of increases annually.
 - *Review of Utility User Fee Rates* – Rates are reviewed annually for possible adjustments. Rates were increased for water on May 1, 2018, and sewer on January 1, 2018, by 4.92 and 10.00 percent respectively. Sewer rates increased by 7 percent on January 1, 2019. Water rates will be reviewed in 2019 for a possible rate increase in late 2019 or early 2020.
 - *Property Tax Levy Increases* – Increases in the property tax levy should not result in an equalized tax rate increase more than inflationary levels. The city's equalized tax rate in 2018 (to fund the 2019 budget) of \$8.97 is a decrease of 4.32 percent over the previous year's rate of \$9.37.
 - *Use of Donations between TIDs* – The city has a number of well performing Tax Incremental District (TID) with capacity to donate to other underperforming TIDs.
 - *Debt Policy* – This policy establishes parameters for issuing and managing debt. No more than 60 percent of the State of Wisconsin's limit of 5 percent of equalized value.

A financial projection of the General Fund, Debt Service Fund and tax levy requirements is included in the LTFP. An analysis of the TIDs is conducted annually.

An analysis of General Fund revenues and expenditures as well as the General Fund's fund balance is conducted annually. Based on actual and current budgeted revenues and

expenditures as well as annual CPI changes, a five year forecast was developed.

**General Fund
Revenue Assumptions**

Revenue Assumptions:

- Property Tax Levy – Current State limits continue. Tax levy increases for all funds limited to net new construction (floor of zero percent), adjustments to debt service, and additional adjustments due to annexations, transfer of services to/from another municipality, adjustments due to increases of fees for tax levy supported services and amounts approved by referendum. The levy is projected to increase slightly due to a majority of net new construction development occurring in TIDs. For the benefit of the 2019 debt service expenses, \$225,000 of additional property taxes was included in the 2019 budget.
- Intergovernmental Revenue – Current State funding continued. Mostly stable continuation of transportation aids, expenditure restraint program, state shared revenue program and recycling grant. This revenue category is projected to remain stable. The exception is Transportation Aids which will continue to increase based upon the State formula which recognizes the city's increase in transportation-related expenses.
- All Other Revenue – Includes Permits and Licenses, Fines and Forfeitures, Charges for Services, and Miscellaneous Income. Slight increase anticipated in construction-related permits due to construction activity of multi-family housing units. All other revenues in this classification anticipated to remain stable.
- Other Financing Sources – Conservatively estimated with slight change or no change.

**General Fund
Expenditures Assumptions**

Expenditure Assumptions

- Personnel Expenditures - Wages and benefits, including Wisconsin Retirement System (rates determined by the state) and health insurance (self-insured by the City of Sheboygan). A major portion of expenditures are wage related. Consistent with collective bargaining agreements for wage increases, a 2.25 percent wage increase is included in the 2019 budget. For the second consecutive year, a 10 percent increase in health insurance rates is included in the 2019 budget.
- Non-Personnel Expenditures – Contracted services, office supplies, utilities, gasoline, liability and property insurance, training and conferences and communication are the main expenses.

Based upon these assumptions, the 2019 General Fund budget will utilize approximately \$1,165,778 in fund balance. Due to conservation budget assumptions, it is anticipated that little to no actual use of these funds will be necessary. Regardless, the General Fund budget projects a fund balance which will exceed the fund balance policy of maintaining a minimum of 25 percent.

Tax Levy Revenue

Tax Levy Revenue – Tax levy revenue is the largest revenue source for city services and projects.

Tax levy revenue is collected for the following funds:

- General – Largest tax levy portion is allocated to this fund which is the operating fund of the city. Increases in the property tax allocation are expected to increase slightly.
- Library – Tax levy portion allocated to Mead Public Library Fund will increase in 2019 slightly for the second consecutive year.
- Park, Forestry and Open Space – Tax levy funding, which was first allocated in 2017, will continue to be \$110,000 to fund capital items.
- G.O. Debt Service – Tax levy portion allocated to G.O. Debt Service Fund will continue to increase to accommodate the increase in annual debt service payments, which are the result of an aggressive street improvement plan.
- Capital Projects – Tax levy for capital projects has been allocated to the Capital Project Fund, starting with the 2017 Annual Program Budget. In the 2019 budget, the amount allocated has declined slightly.
- Transit – Tax levy portion allocated to the Transit Utility Fund has remained stable for the past seven years.

Tax levy limits under current state law may change with future legislation. Changes to the law will require adjustments to future long-range forecasts as necessary. Future limitations could impact the ability of the city to deliver services.

Summary

The LTFP is designed to be a dynamic document that is modified based on current or new conditions. External factors play a key role in determining the financial picture of the city. The external factors include legislation approved by the State of Wisconsin, development and the economy. These factors may impact the financial picture positively or negatively.

The current financial situation reflects a strong financial position, prudent fiscal practices and solid reserves for the funds included on the LTFP.

CITY OF SHEBOYGAN

REQUEST FOR FINANCE AND PERSONNEL COMMITTEE CONSIDERATION

ITEM DESCRIPTION: R.O. No. XX-18-19 accepting the 2019 Long Term Financial Plan.

REPORT PREPARED BY: Darrell Hofland, City Administrator

REPORT DATE: September 5, 2018

MEETING DATE: February 25, 2018

FISCAL SUMMARY:

Budget Line Item: N/A
Budget Summary: N/A
Budgeted Expenditure: N/A
Budgeted Revenue: N/A

STATUTORY REFERENCE:

Wisconsin Statutes: N/A
Municipal Code: N/A

BACKGROUND / ANALYSIS:

The City of Sheboygan recognizes a long term financial plan will be a valuable tool combining financial forecasting with the Strategic Plan. The process combines future scenarios to assist in the navigation of challenges. The Long Term Financial Plan forecasts projected revenue and expenses using assumptions about economic conditions and future spending to align with long term objectives.

STAFF COMMENTS:

Governments utilize a comprehensive long term financial plan to stimulate discussion and engender a long range perspective for decision makers. It can be used as a tool to prevent financial challenges while it stimulates long term strategic thinking. In addition, it can give consensus on long term financial direction and is a useful tool for communications with internal and external stakeholders.

Attached is an update to the Long Term Financial Plan which was approved by the Common Council in September, 2018.

ACTION REQUESTED:

Motion to recommend the Common Council accept and file R.O. No. XX-18-19 by the City Administrator accepting the 2019 Long Term Financial Plan.

ATTACHMENTS:

- I. R.O. No. XX-18-19
- II. Long Term Financial Plan

VI

R. C. No. _____ - 18 - 19. By LICENSING, HEARINGS, AND PUBLIC SAFETY
COMMITTEE. March 4, 2019.

Your Committee to whom was referred R. O. No. 221-18-19 by Chief of
Police submitting the annual report of the Sheboygan Police Department for
the year 2018; recommends filing the document.

Consent

_____ Committee

I HEREBY CERTIFY that the foregoing Committee Report was duly accepted
and adopted by the Common Council of the City of Sheboygan, Wisconsin, on the
_____ day of _____, 20__.

II

3.3

R. O. No. 221 - 18 - 19. By CHIEF OF POLICE. February 18, 2019.

Submitting the annual report of the Sheboygan Police Department for the year 2018.

*SHPS
Accept & file*

Chief of Police, Christopher Domagalski

SHEBOYGAN POLICE DEPARTMENT

Annual Report 2018



Christopher Domagalski, Chief of Police
1315 N. 23rd Street, Suite 101
Sheboygan, WI 53081



TABLE OF CONTENTS

SPD Vision, Mission & Values	p. 3-5
Alderpersons	p. 6
Table of Organization	p. 7
Police & Fire Commission	p. 8
Chief's Message	p. 9
2019 Goals	p. 10-13
Budget	p. 14
Internal Investigations	p.15
Use of Force & Search Warrants	p. 16
New Hires & Retirees	p. 17-18
SPD K9s	p. 19
Administrative Services Division	p. 20-23
Criminal Investigation Division	p. 24-28
Patrol Division	p. 29-33
Information Services	p. 34-39
Community Outreach	p. 40-54
SPBA Service Awards	p. 55-58
Community Partners	p. 59-61



Our Vision

To be the safest
community of
its size in the
United States.

Our Mission

is to be the model of excellence in policing by working in partnership with the community and others to:

- FIGHT crime, the fear of crime and disorder;
- ENFORCE laws while safeguarding the constitutional rights of all people;
- PROVIDE quality service to all our residents and visitors; and
- CREATE a work environment in which we recruit, train and develop an exceptional team of employees.



Our Values

Integrity

Teamwork

Leadership

Competence

Accountability

Professionalism



City of
Sheboygan
spirit on the lake.

Mayor Michael Vandersteen
Chief Administrative Officer Darrell Hofland

District	Wards	Aldersperson	District	Wards	Aldersperson
1	1, 5, 6	Ronald Rindfleisch	6	18, 19	Dean Dekker
2	2, 3, 12	Todd Wolf	7	14, 15, 21	Rose Phillips
3	11, 13	Mary Lynne Donohue	8	20, 24	Ryan Sorenson
4	4, 7, 10	Rosemarie Trester	9	22, 25	Trey Mitchell
5	8, 9, 16, 17	Markus Savaglio	10	23, 26	Jim Bohren



Chief of Police

2018 Table of Organization

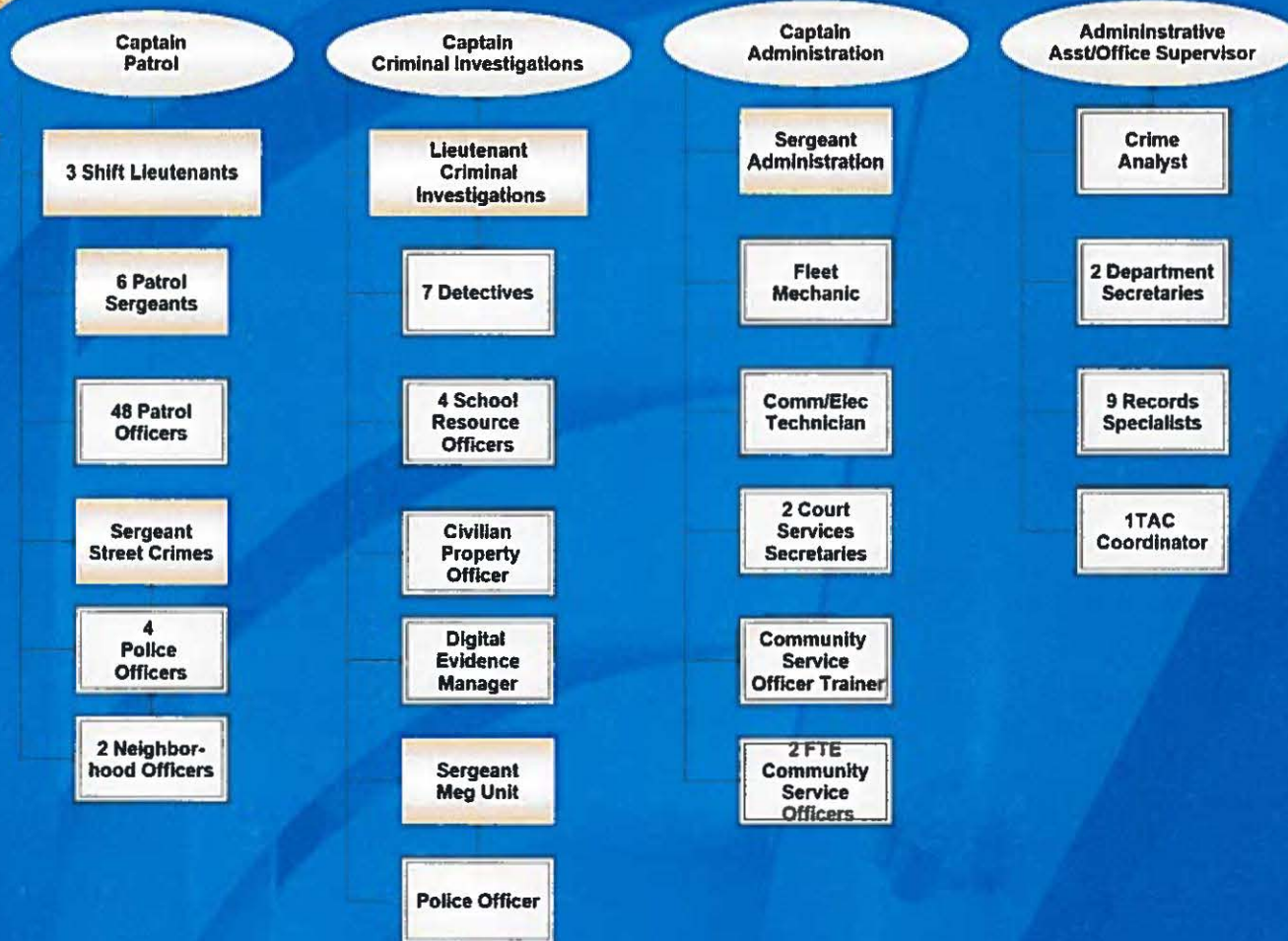

Police & Fire Commission 2017-2018

President Robert Lettre, Sr.
Secretary Andrew Hopp
Commissioner Henry Jung
Commissioner Jeanne Kliejunas
Commissioner Larry Samet



The 2018 Sheboygan Police Department Annual Report is herein presented for your review. The report documents the department's challenges, accomplishments and key activities.

In 2018 we continued to focus our training on dementia awareness, resiliency, less lethal options, rapid response to active shooter events, and scenario based training to build the skills for responding to individuals in crisis.

Neighborhood Policing, which shaped many of my early patrol experiences, is a key to many of our successes. Neighborhood policing is connecting our officers with the citizens they serve and strengthening the relationships already in place. We have found that we can increase our effectiveness and the public's trust by building relationships, before crisis, one contact at a time. These contacts and the relationships we build are the key to solving problems in our city. Our work continues to become more complicated and often requires us to serve as a facilitator and to collaborate daily with our community partners.

In many neighborhoods community members are stepping up and taking responsibility for their neighborhoods, creating new partnerships and renewing neighborhood pride. It is vitally important that officers not just answer calls for service, but also have the time to interact with the public and engage in local crime fighting and real problem solving with the people who live and work in our neighborhoods. As officers and citizens work together to solve problems a mutual respect is developed as well as a mutual understanding that creating safe communities is a shared responsibility.

When employees retire they take along with them invaluable experience and knowledge that takes years to replace. Fortunately we have been able to recruit and hire replacements with strong character, a passion to serve others, and a robust desire to learn.

While we have accomplished much, we have much more to do. I look forward to working with the great men and women of the Sheboygan Police Department and our many partners to take on the challenges that we encounter as a community in 2019. I am confident that we are up to the task and look forward to working with you.

Sincerely,

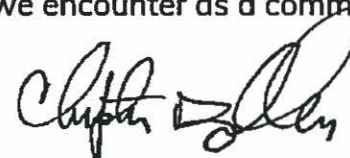

Christopher Domagalski, Chief of Police



2019 SHEBOYGAN POLICE DEPARTMENT GOALS

Goal # 1 – Reduce Crime, Fear and Disorder

Activities: Effectively apply CompStat principles in our daily work.
Focus on prevention and asking the next question to identify and solve problems.
Use crime analysis to create tactical intelligence for use in directing police resource decisions.
Continue partnerships to address blight and revitalize neighborhoods.
Use data to drive enforcement efforts related to traffic safety.
Identify Prolific Offenders and work with Prosecutors, the Courts and Probation and Parole to connect them with treatment and support services and/or develop criminal cases for prosecution.
Continue involvement in the Sheboygan County Criminal Justice Advisory Committee and activities that support universal screening and assessment and the development of treatment, monitoring and support services.

Expected Outcomes: Maintain or Reduce Part 1 Crimes including an overall Part 1 Crimes target of 1150.
Individual crime targets as follows: of Robbery \leq 15, Aggravated Assaults \leq 100, Burglary \leq 100 and Theft \leq 900.
Total Accidents \leq 1500.
High Visibility Education and Enforcement Deployments = 12.
Pounds of prescription drugs collected \geq 1200

2019 SHEBOYGAN POLICE DEPARTMENT GOALS

Goal # 2 – Build Community Trust

Activities: Increase department messaging through the coordinated and timely release of information.
Build Neighborhood capacity by continuing to promote Neighborhood Associations.
Increase direct contact with citizens through neighborhood meetings, park and walk and bicycle patrols.
Identify community issues and address through collaborative approach at the neighborhood level.
Work with our youth and schools to enhance safety and security for students.
Continue ongoing efforts to educate the public regarding drug and alcohol abuse.
Maintain and leverage Beat Officer Positions.

Expected Outcomes: An informed community and greater awareness and understanding of department activity.
Enhanced relationships and understanding of the police role across the community.
Coordinate and hold more than 25 neighborhood meetings.
Increase in collaborative problem solving in the community.
Increase in measurable deployments of foot and bicycle patrols.
Maintain percentage of residents that feel safe walking in their neighborhood during the day at greater than 80%.
Increase in the percentage of residents that feel safe walking in their neighborhood at night above 70%.
Increase in Police legitimacy.

2019 SHEBOYGAN POLICE DEPARTMENT GOALS

Goal # 3 – Create an Organization that Embraces Innovation and Creates Opportunities to Improve

Activities: Continue evaluation of workflow and position responsibilities to support department activities and mandates.
Continue training and redesign of associated processes and responsibilities.
Continue ongoing evaluation of digital platforms to increase stability, efficiency and reliability.
Emphasize the connection of department values to daily decision making and develop values based Code of Conduct.
Practice the judicious and impartial use of police authority.

Expected Outcomes: Create Public Value by operating within the authorized budget and working towards continuous improvement.
Improved stability, efficiency and reliability of digital platforms.
More dependable systems and enhanced customer service.
Clear internal expectations and procedural justice.
Increased in voluntary compliance with community norms, decrease in the use of force and increased police legitimacy.

2019 SHEBOYGAN POLICE DEPARTMENT GOALS

Goal # 4 – Enhance Employee Culture and Morale and Create an Environment where Employees have a heightened sense of Pride in the organization.

Activities:

- Ensure Goals and Objectives are set for all Employees during evaluation process and tie evaluation to organizational goals and personal development plan.
- Celebrate Successes of Organization.
- Deliver key training across department.
- Continue Leadership in Police Organization training for all levels of the department and increase ownership of problems and concerns.
- Continue department advisory group to identify issues, improve feedback, offer ideas and find solutions.

Expected Outcomes:

- Greater Camaraderie, Trust and Pride among all Police Department employees.
- Enhanced employee motivation, satisfaction and pride in the organization.
- Healthier and more resilient workforce.
- Stronger working relationships.

2018 SPD BUDGET

Administration	\$1,623,855.00
Patrol	\$7,054,479.00
Fleet Maintenance	\$252,281.00
Parking Enforcement	\$125,002.00
Facility	\$170,290.00
Criminal Investigation Division	\$2,191,366.00
Total Budget	\$11,417,273.00

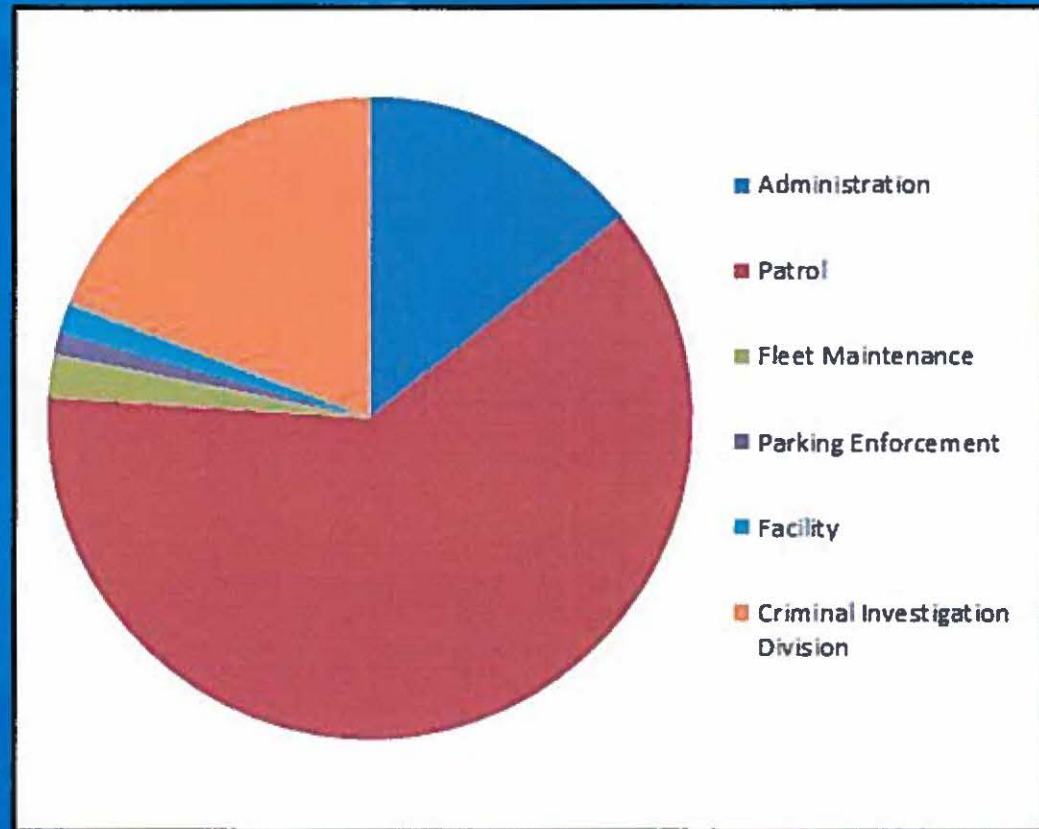

2018 Internal Investigations



Twenty-three (23) internal investigations were conducted in 2018. Of those investigations, sixteen (16) were initiated by the Department, and seven (7) were citizen complaints.

2018 INTERNAL INVESTIGATIONS

INVESTIGATIVE FINDINGS	#
SUSTAINED	15
NOT SUSTAINED	0
UNFOUNDED	1
EXONERATED	0
NO FORMAL COMPLAINT	0

2018 CITIZEN COMPLAINTS

INVESTIGATIVE FINDINGS	#
SUSTAINED	1
NOT SUSTAINED	0
UNFOUNDED	2
EXONERATED	2
NO FORMAL COMPLAINT	2

- Sustained = The allegation is supported by sufficient proof.
- Not Sustained = The evidence is not sufficient to prove or disprove the allegation.
- Unfounded = The allegation is false or otherwise not based on valid facts.
- Exonerated = The incident that occurred or was complained against was lawful and proper.

2018 Use of Force & Search Warrants



2018 USE OF FORCE	
DEADLY FORCE	0
DISPLAY FIREARM	89
DISPLAY ELECTRONIC CONTROL DEVICE	38
DEPLOY ELECTRONIC CONTROL DEVICE	7
EMPLOY ACTIVE COUNTERMEASURES	5
APPLY HOBBLE DEVICE	3
DEPLOY SPECIALTY IMPACT MUNITIONS	1
DEPLOY OLEORESIN CAPSICUM SPRAY	0
CANINE BITE	0

MONTH	SEARCH WARRANTS
January	7
February	14
March	17
April	11
May	11
June	9
July	9
August	13
September	6
October	12
November	12
December	5
Total	126

New Hires in 2018

6 new officers joined the SPD in 2018. Officers Bryan Pray and Abigail Hernandez took the oath in January. Officers Chelsea Hundt and Jeremy Kegler were sworn in during May. Officer Sean Goffard joined the SPD in August, followed by Officer Michael Moore in October.

We also welcomed a new Community Service Officer, Kendra Zipperer, in January and new Time Agency Coordinator, Melissa Bartell in March.



Officer Bryan Pray



Officer Abigail Hernandez



Officer Chelsea Hundt



Officer Jeremy Kegler



Officer Sean Goffard



Officer Michael Moore



CSO Kendra Zipperer



TAC Melissa Bartell

2018 Retirees

We said goodbye to three fantastic longtime employees this year. Linda Repphun retired from her position as Time Agency Coordinator in March after over 43 years with the SPD. Officer Larry Helmer retired in April after 31 years and Officer Charlet Endsley bid farewell in December after 28 years.

We will miss them and wish them well in their future endeavours.



Linda Repphun



Officer Larry Helmer



Officer Charlet Endsley





Officer Saeger
and retired K9 Bud

K9 Bud retired this year on Monday, December 10th after 10 dedicated years of service with Officer Saeger. We miss his apple eating antics but we know that he will enjoy the good life at home.

In 2018,

K-9 Units conducted **265** traffic contacts, **12** demonstrations, **8** search warrants and **12** scheduled school searches.

Our current dogs, K9 Max and K9 Grimm, are on the road every day creating a bridge between the SPD and the community. The City's canines help us battle the influx of drugs and track criminals. The canines are also capable of helping us find vulnerable individuals who may be lost and bring them back home. Our canines also support public relations by generating positive conversation between police and our community.

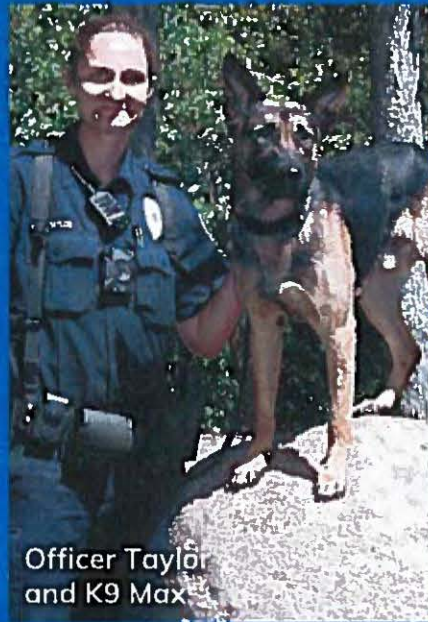

Officer Taylor
and K9 Max



Officer Heimerl
and K9 Grimm

The Sheboygan Police Department Canine Unit is seeking support through community donations.

We are grateful to those who have supported our K-9 program in the past and we need your help to maintain our current level of K-9 services.

Visit our GoFundMe page or contact Sgt. Ryan Schmitt, (920) 459-3333

 gofundme.com/sheboygan-police-k-9-fund



ADMINISTRATIVE SERVICES DIVISION

Captain Steve Cobb

The Administrative Services Division is responsible for a variety of support services throughout the department. This includes documenting the training of all department members, recruiting and screening candidates to fill entry level Police Officer positions, managing the police facility and managing the offices of the Sergeant of Administration, Court Services Division, Police Fleet Services, Radios and Communications, and the Volunteer in Police Service Corps.

The Sergeant of Administration is responsible for managing individual members training, supervising the department's Community Service Officers and School Crossing Guards, managing the departments parking enforcement and traffic functions, and coordinating the Sheboygan Police Citizens Academy.

Court Services manages the transfer of all case information between the Police Department and the City Attorney's office or the Sheboygan County District Attorney's office. This office ensures that there is an efficient transfer of case information and scheduling between the SPD and our prosecuting authorities.

The Police Fleet consists of 41 different vehicles. Our fleet manager is responsible for general maintenance and repairs of all vehicles. In addition, each year, the fleet manager is responsible for conversion of newly purchased vehicles into Police Vehicles.

The primary responsibility of the Radio and Electronic Technician is working in support of the Sheboygan County Radio system to ensure that there is an effective radio communications network in place. This involves service to over 300 mobile and portable radios that function within the City. In our role as a County partner in this project, our technician supports any radios on our county network. In addition, this office maintains the 911 emergency phone systems, and the City of Sheboygan telephone network.

TRAINING AND CAREER DEVELOPMENT

Over the course of 2018, department goals were supported by providing training in the recognition of dementia as a condition that challenges police-citizen encounters. Training was provided in the presence and recognition of dementia, as well as strategies to help with those interactions. Training purchased through Second Wind Dreams was provided to the SPD Organization, and made available to both city staff and the public. In addition to dementia training, every member of the organization received 8 hours of training focused on resiliency within Law Enforcement organizations.

Over **10,813** hours of training to sworn personnel, average of 131 hours per officer.

6 members of the Police Department attended Leadership in Police Organizations academies.

32 hours of in-service training provided to all sworn personnel.



28 hours of policy training on average provided per employee through the use of daily training bulletins.

Facilitated the attendance of **1** Lieutenant to the FBI National Training Academy.

ADMINISTRATIVE SERVICES DIVISION



In a continuing effort to maintain compliance with the Juvenile Justice Delinquency Prevention Act, we continued training and auditing of all juveniles held securely at the Sheboygan Police Department. New policy and training led to only **22 secure juvenile holds** at the Sheboygan Police Facility, reduced from 203 (90%) from when auditing began in 2015.



Facility Improvements in support of the Green Initiative include the installation of high efficient hot water systems, and the conversion of indoor halogen accent lighting to LED.



Managed hiring processes that resulted in the **hiring of 6 officers** during calendar year 2018, and established eligible candidates for 2019 vacancies.



Administered a Police Citizen Academy that **trained 18 citizens** over 11 weeks.



Completed Phase I of the **new VOIP City Telephone system.**



Converted **5 new vehicles** into Police Service.

ADMINISTRATIVE SERVICES DIVISION

Volunteers in Police Service

The Administrative Services Division oversees 12 volunteers who provide a variety of support services and do not receive any compensation. Our VIPS staff provides assistance in the police records and court services area, as well as giving tours of the facility to community groups.

They assist by serving subpoenas, helping with collections from the prescription drug drop off box, doing civilian fingerprinting, and numerous other assignments.

VIPS are led by Coordinator Penny Weber. Other members include: Mary Ann Dickfoss, Joe Glover, Jr., Jason Lawrence, Kristi Lawrence, Connie Mehan, Ethel Pillman, Sherry Rebholz, and Tom Riemann. Volunteers also include three police department chaplains, Rev. Mario Ciotola, Rev. Lori Ciotola and Rev. Ethan Tews. The Sheboygan Police Chaplaincy program was developed to serve as a resource to provide spiritual and emotional support to members of the department, their families and members of the public.

During 2017, VIPS donated **1,803** hours!

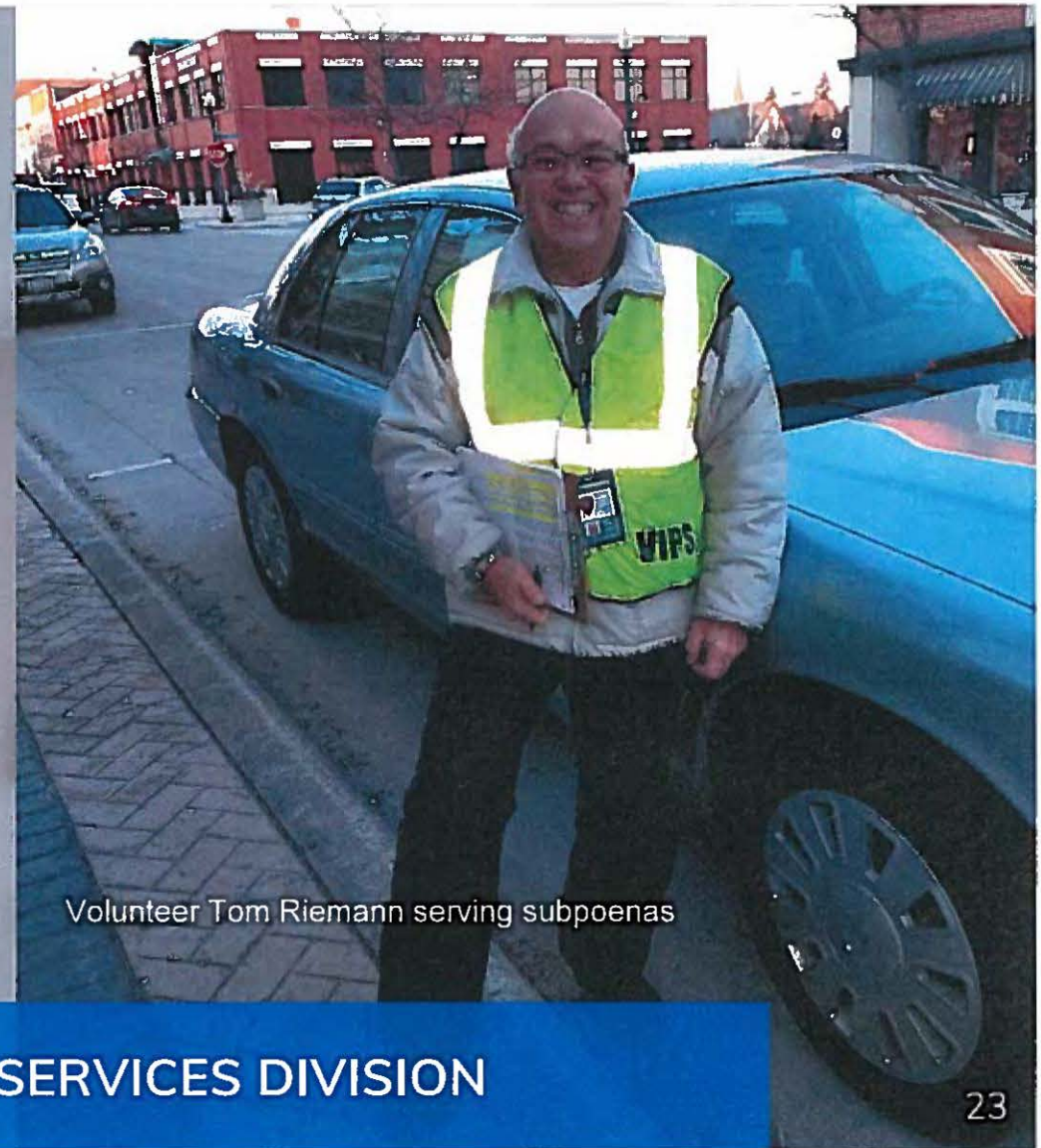

Volunteer Tom Riemann serving subpoenas

ADMINISTRATIVE SERVICES DIVISION



CRIMINAL INVESTIGATION DIVISION

Captain Kurt Brassler

The Criminal Investigation Division encompasses the Detectives, School Resource Officers, MEG Unit, the Property/Evidence Officer and the Digital Evidence Manager. The Division is responsible for the more complex investigations including homicide, robbery, sexual assault, identity theft, forgery and burglary.

2018 was a busy year. Lt. Teunissen graduated from the FBI academy in the spring. The Division hosted 2 Best Practices for Sex Assault Investigations Training with 41 officers attending, and the Captain of CID is currently serving on a DOJ committee to establish best practices for sex assaults statewide. An internal sex offender waiver procedure was also updated after an ordinance change. Cell phone analysis and evidence collection was also a focus, with training provided at SPD In-Service and updated temporary locker procedures for cell phone analysis. School Resource Officers conducted 25 Site Safety Assessments for SASD and private/parochial schools. The Digital Evidence Manager successfully launched a new discovery sharing process via the cloud for body camera files.

Breakdown of the Cases Assigned to CID

Total	447
Cleared by Arrest	75
Closed	88
Active	62
Inactive	28
Sit Resolved	30
Unfounded	16
Information Only (Intel)	128
Other	20

Breakdown of the Cases Assigned to School Resource Officers

Total	713
Cleared by Arrest	402
Closed	71
Active	14
Inactive	21
Sit Resolved	187
Unfounded	9
Other	9

CRIMINAL INVESTIGATION DIVISION

77
Sex Offender
Waiver
Background
Investigations

42
Child Interviews
at the Child
Advocacy
Center

1,160
Cases assigned
to CID

693
Forensic Phone
Downloads

105
Outreach Events
This number includes events
provided exclusively by CID &
events where CID participated
with other department
personnel

**Internet Crimes Against
Children (ICAC) Cases**

Investigations	13
NCMEC Tips (National Center for Missing and Exploited Children)	9
Subpoenas	14
Gigabytes Examined	1733
Arrests	5

CRIMINAL INVESTIGATION DIVISION

Open Records Requests
for Digital Files
262

Discovery Requests for
Digital Evidence
1,321

Since August,
519 cases shared
via the cloud with
3,424 total video files

Total number of property & evidence items
logged into the SPD property room
3,525

Total number of property & evidence items
purged or returned
1,545

423
Items processed
at the Crime Lab

CRIMINAL INVESTIGATION DIVISION

The MEG Unit

19

Search
Warrants

125

Drug
Charges

8,697^{gms}

Of Illegal
Drugs
Seized

39

Community Talks about Drug
Awareness & the Opioid Crisis



PATROL DIVISION

Captain James Veaser

The Patrol Division is the largest division within the Police Department consisting of 63 sworn personnel. The division is led by a Captain, 3 Lieutenants and 7 Sergeants. The patrol division is the backbone of the department and provides the most visible level of service to the community. Patrol Division members are selected for full time assignments to the Street Crimes Unit, K9 Unit and Neighborhood Beat Officer.

Members also volunteer and are selected to serve in the following special assignments: Emergency Response Team, Motorcycle Unit, Explorer Post Advisor, Accident Reconstruction Unit, Armorers, Probationary Training Officers, and Honor Guard Team.



In **2018**, Neighborhood Beat Officers continued revitalization, community partnership building and enforcement efforts on both the north side and south side of Sheboygan.



The Patrol Division transitioned from 1st generation X26 Tasers to **X26P Tasers** while also replacing 1st generation Level One Oleoresin Capsicum (OC) with the next generation **Level Two Sabre Red**.



The Emergency Response Team finalized purchasing plans to upgrade to **15 new, higher quality ballistic vests** and will be fitted in 2019.



All police personnel transitioned from syringe based Narcan disbursement to nasal disbursement. Officers administered **5 doses of Narcan** at the scenes of overdoses in 2018



Sheboygan Police, through Patrol and K-9 efforts, **seized \$8,130** attributed to narcotic sales

PATROL DIVISION



The Street Crimes Unit conducted **7 search warrants** and apprehended **82 individuals** on warrants. They seized **884.27 gms** of THC, **21.23 gms** of methamphetamine, **17.6 gms** of cocaine, **1.96 gms** of heroin, **49.2 gms** of MDMA, **72 doses** of LSD, and **310 pieces** of paraphernalia.



The Sheboygan Police Department maintains a Crash and Crime Scene Reconstruction Unit. In 2018 the unit responded to **2** fatal motor vehicle crashes.



The Patrol Division provided on site ALICE training at **13 local businesses** in Sheboygan over the 2018 calendar year.



On August 8, 2018, the SPD held its first large group instruction on **Active Shooter Response attended by 32 people.**

It was held in the LGI room at South High School. Topics covered in the training included CPTED (Crime Prevention through Environmental Design) History of Active Shooter Events, ALICE Active Shooter Response, and Scenario Training.

PATROL DIVISION

The Sheboygan Police Department initiated an educational and enforcement traffic program in 2018 called "Car in Gear, Brain in Gear". The effort focused on educating the public on how to avoid becoming a participant in an accident while enforcement focused on connecting with those who likely will cause an accident due to their driving behavior.

The effort resulted in a **3.4% decrease in accidents** compared to 2017 numbers (1736 to 1677).

Data collected during 2018 indicates that Friday, Tuesday and Monday are the most likely days that an accident occurs while the most likely times are between 7 AM to 8 AM, Noon and 2 PM, and 3 PM to 5 PM. **The most probable time of being involved in an accident was between 3 PM to 4 PM on a Friday.**



Making Sheboygan Safer Together

PATROL DIVISION

Conducted
5,270
Traffic Stops

4,509
citations issued

2,938
warnings issued

9,032 parking citations issued

1,722 city ordinance citations issued

1,690 nuisance complaints investigated

Responded
to **519**
alarms

761
abandoned vehicle
complaints investigated

179
abandoned vehicles
towed

Detained & Filed Emergency Detention Commitments on **121** individuals.

PATROL DIVISION



INFORMATION SERVICES DIVISION

Paula Haelfrisch

The Information Services Division of the Sheboygan Police Department consists of the following positions: 1 Administrative Assistant/Office Supervisor, 1 Crime Analyst, 1 Time Agency Coordinator, 2 Department Secretaries, 7 Records Specialist Clerks, 1 PT Records Specialist Clerk, 1 LTE (limited term employment) Records Specialist Clerk.

The civilian staff continues to provide support to the sworn personnel of the Sheboygan Police Department at various levels. New this year, was the entering of parking tickets into Badger TRACS with an automatic import into the MUNIS parking ticket program.

The following slides contain statistical data compiled by the Crime Analyst.

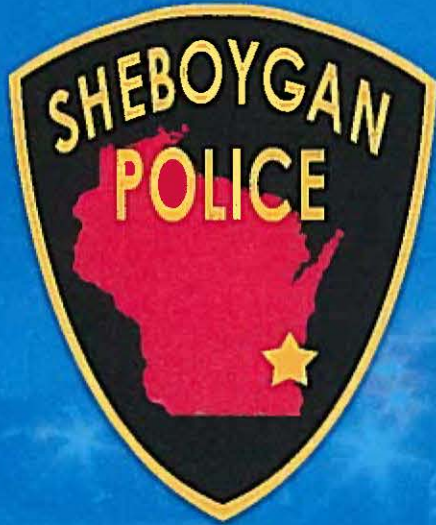

25,885

TOTAL NUMBER OF LAW INCIDENT COMPLAINTS FOR
THE CITY OF SHEBOYGAN POLICE DEPARTMENT IN 2018



Part I Crimes

	2013	2014	2015	2016	2017	Average	2018
Homicide	1	1	0	1	0	1	0
Rape	20	20	22	20	24	21	21
Robbery	14	17	14	10	11	13	11
Agg. Assault	97	116	124	100	85	104	128
Violent	132	154	160	131	120	139	160
Burglary	187	161	128	119	91	137	89
Theft	1023	1082	991	908	702	941	703
MV Theft	31	24	31	36	32	31	25
Arson	6	12	4	5	12	8	8
Non-Violent	1247	1279	1154	1068	837	1117	825
Total Part I	1379	1433	1314	1199	957	1256	985

5 Year Average

Part I Crimes	Homicide	Rape	Robbery	Aggravated Assault	Burglary	Theft	MV Theft	Arson	Total Part I Crimes
2018	0	21	11	128	89	703	25	8	985
5 Year Average	1	21	13	104	137	941	31	8	1256
Difference	-100%	0%	-15%	23%	-35%	-25%	-19%	0%	-22%

2018 Goals

Offenses	Goal	Actual	Difference	Percent
Robbery	15	11	-4	-27%
Aggravated Assault	90	128	38	42%
Burglary	100	89	-11	-11%
Theft	900	703	-197	-22%
Total Part I	1,175	985	-190	-16%

Violent Crime

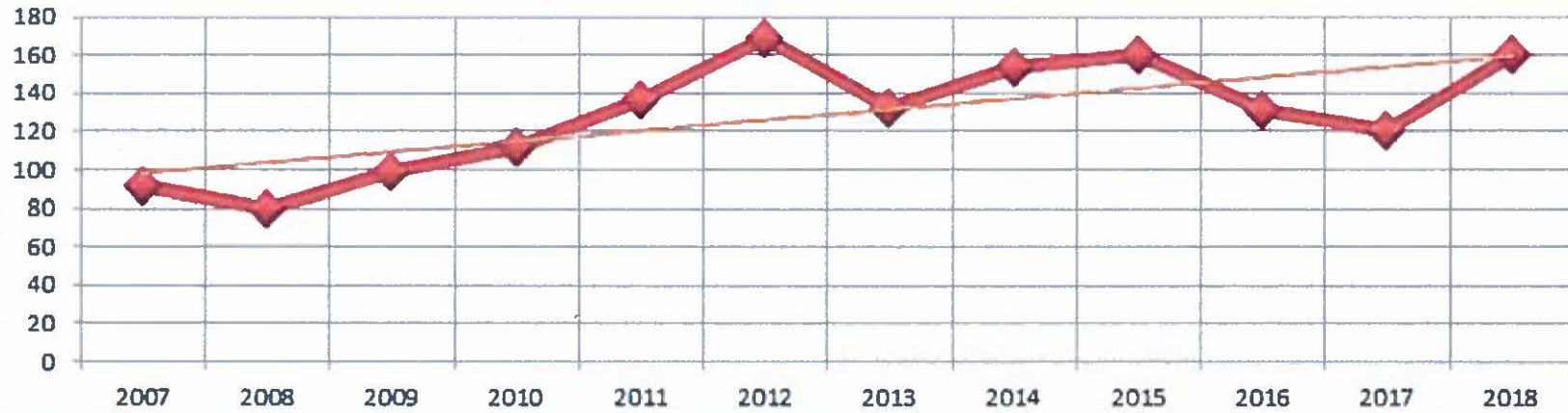

Non-Violent Crime

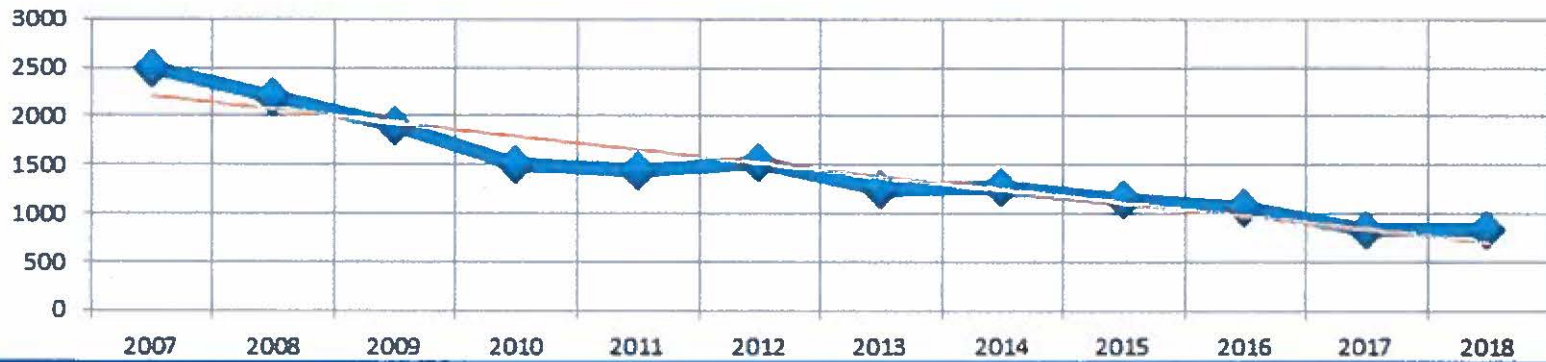



2018 Traffic Accident Data

2017 Total	1736	2018 Total	1677	Difference	59	Percent	-3%
-------------------	-------------	-------------------	-------------	-------------------	-----------	----------------	------------

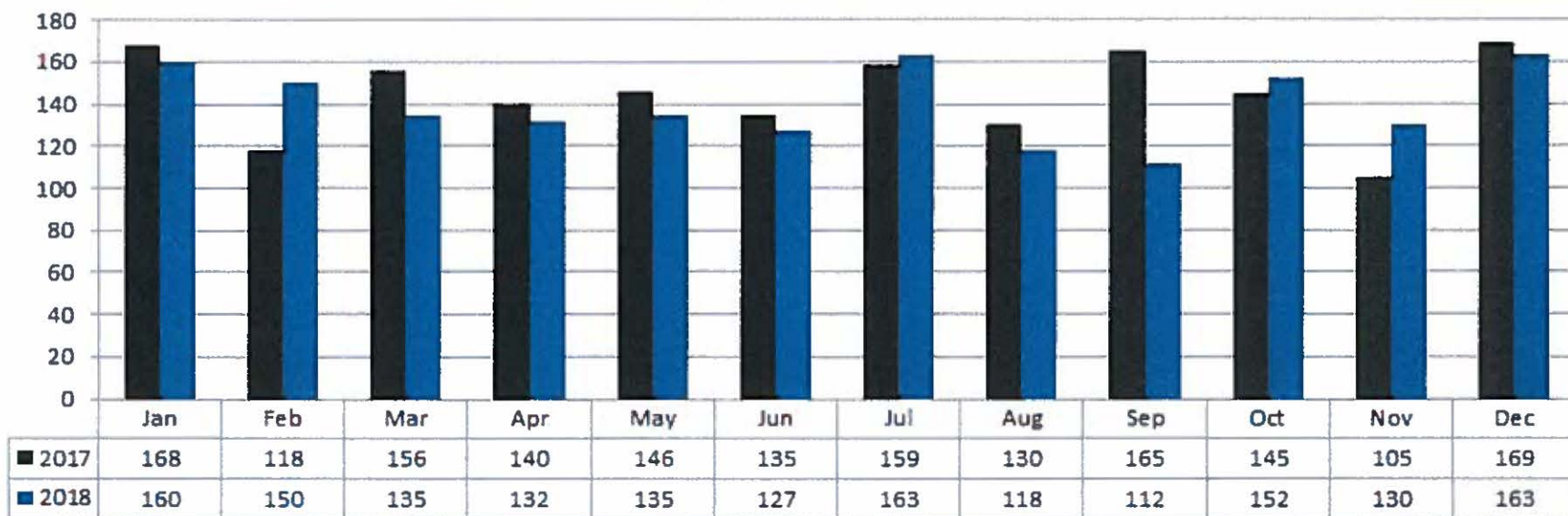

A photograph of a community outreach event. In the foreground, two police officers in dark uniforms are looking towards a large crowd of people in the background. The officer on the right has a patch on their sleeve that says "COMMUNITY COUNCIL" with a red map of a city. The scene is indoors, possibly in a community center or school, with various items and people visible in the background.

Community Outreach

Partnering together to make
our city the best it can be.

The Great Kindness Challenge

January 2018

2018 got off to the right start with officers participating in the Great Kindness Challenge, which encourages people to be kind to others and pay it forward. Some of our first shift officers stopped at Farnsworth Middle School to greet the students with kindness and a positive message.

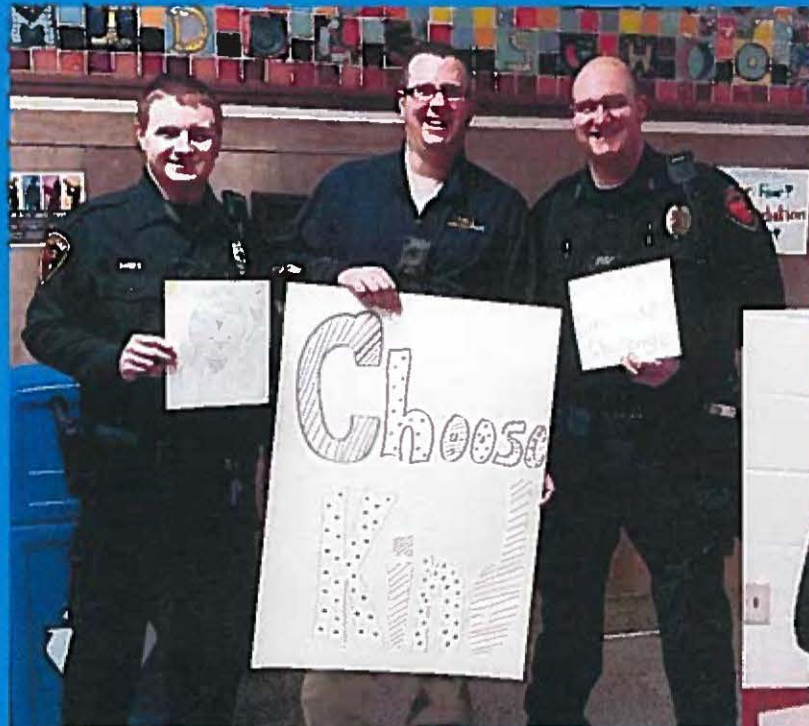

Fun & Games!

Police work is definitely not all fun and games. But throughout the year, SPD officers managed to get their game on and have fun with students and citizens. Our first "Skate with a Cop" event was a great success. "Gaming with a Cop" gave people a chance to take on neighborhood officers. Dodgeball at Farnsworth Middle School brought officers and firefighters together for a friendly competition.



Hop with a Cop

March 24, 2018

SPD Officers and volunteers helped the Easter Bunny hide eggs at James Madison School. Everyone had a great time watching the kids hunt for them.



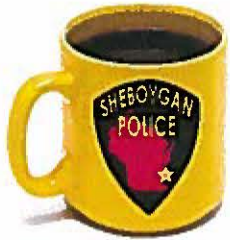

The Sheboygan Police Department continued to build relationships with community members through "Coffee with a Cop." The program has been utilized nationally and has teamed area restaurants with their local law enforcement agencies to achieve the overall goal of opening communication.



Neighborhood Activities

2018 brought many opportunities to promote partnerships between police and the community and build neighborhood camaraderie.

SPD officers teamed up with local residents cleaning up neighborhoods, organizing events and attending meetings.



Indiana Corridor Hot Dog Fry



North Point & Vollrath Historical Walk



James Madison Neighborhood Meeting



Flats Neighborhood Clean Up

Neighborhood Activities

National Night Out and International Overdose Awareness Day were two great summer events.

Officers also gave our first community course on Active Threat Preparedness.

The Department helped organize and participated in two "Rock the Block" events. In partnership with Habitat for Humanity and City Development, volunteers assisted neighborhood residents with exterior projects to beautify neighborhoods and increase neighborhood pride.



National Night out at End Park



International OD Awareness Day at Fountain Park



Community Course on Active Threat Preparedness



Rock the Block in the 1400-1700 Block of South 9th St

2018 Citizen Academy



Over the course of eleven weeks, citizens are provided the opportunity to gain knowledge and a better understanding of the vision, values, goals, and operations of the Sheboygan Police Department. Additional activities involve hands-on participation, such as, high-risk and low-risk traffic stops, shoot-don't shoot exercises and a tour of the Sheboygan County Jail, along with firearms instruction and use at the range.

COPS and Bobbers

The Sheboygan Police Department hosted two Cops and Bobbers fishing trips this season. Children from the area were treated to a day of fishing with SPD officers. Many fish were caught and released and memories were made. At the conclusion of the day the children were each given a fishing rod to take home! Thank you to Cousins Subs for a catered lunch, Roasted Gobblers for the rods and reels, The Wharf for squiggly worms, Shoreline Metro for the bus ride to and from, and Old Wisconsin. A special thank you to our hosts who allowed us to fish at their pond!



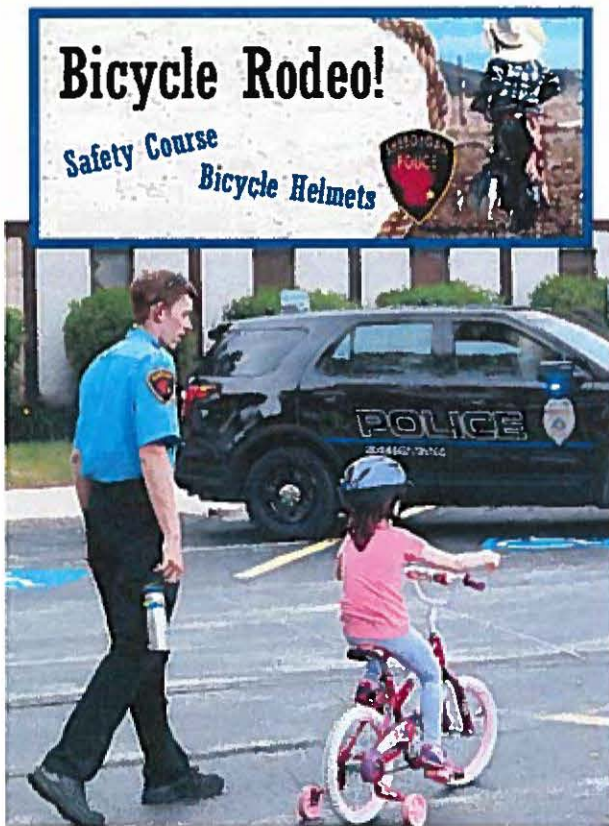

The Sheboygan Police Department and Police Explorers hosted two Bike Rodeos, teaching about bicycle safety and maintenance, in addition to offering helmet fittings, snacks and prizes. The courses have been designed to target elementary school age children, but are open for any child from 6 to 14 years old.

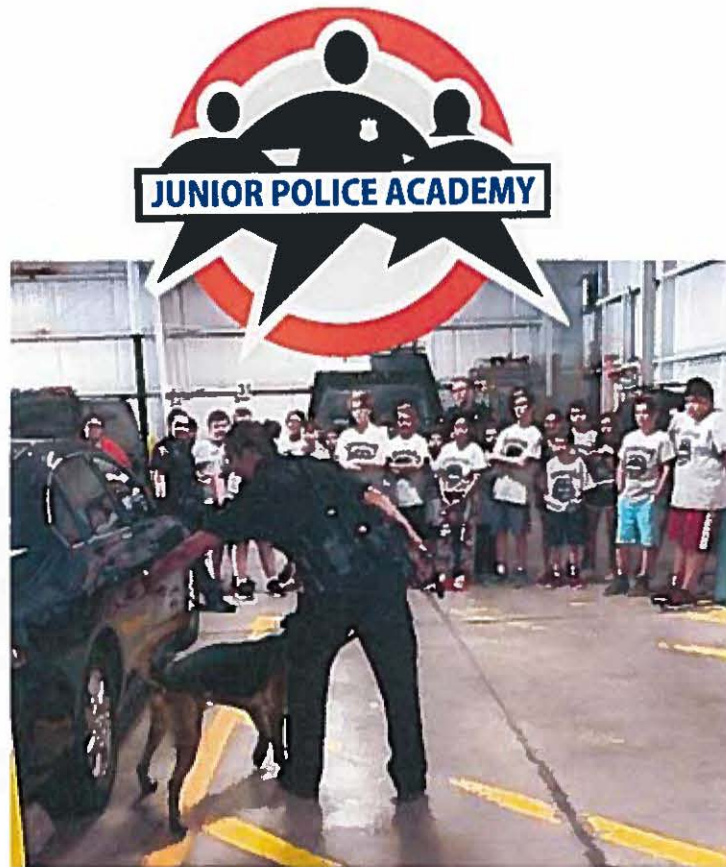

Junior Police Academy is a week-long program that provides a forum not only for officers and students to interact with each other but to inspire good character, advanced citizenship, foster problem-solving & good decision-making skills, in addition to technical instructions about police work to middle school students.

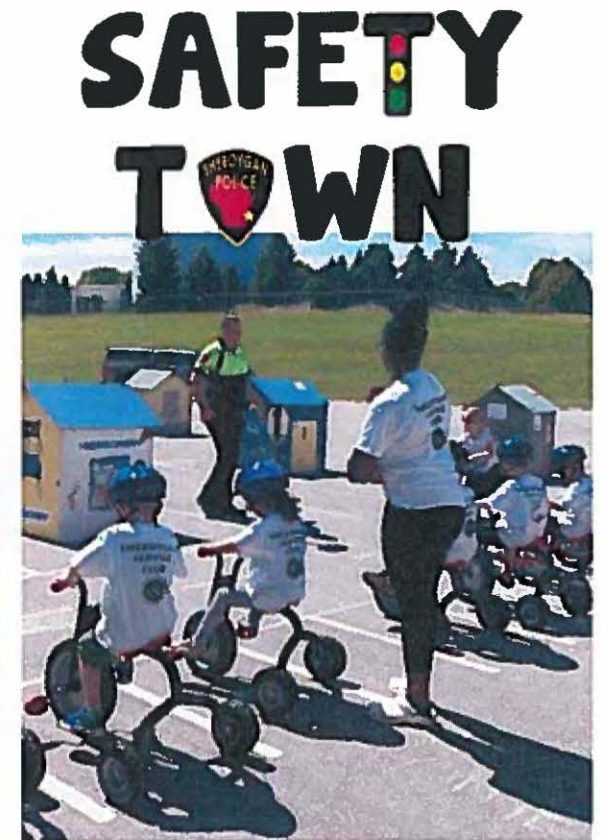

This 15-hour safety education program, co-sponsored by the Sheboygan Service Club & Community Recreation Department, is for children who will be starting kindergarten.. The safety topics include; bike safety, stranger danger, poisons around the house, pet safety, water safety and many lifesaving topics.



National Law Enforcement Officers
MEMORIAL FUND
RESPECT. HONOR. REMEMBER.

2018 POLICE UNITY TOUR



Officer Deutsch (SPD), Sgt. Schmitt (SPD) and Lt. Spence (Sheboygan Sheriff) participated in the Police Unity Tour, riding their bicycles from New Jersey to Washington D.C. The Police Unity Tour raises awareness of Law Enforcement Officers who have died in the line of duty and raises funds for the National Law Enforcement Officer's Memorial Fund. The Tour entered its 22nd year in 2018 and consisted of more than 2,800 riders. The ride takes place during National Police Week in May every year.



The Torch Run is an effort to increase awareness and raise funds for Special Olympics of Wisconsin. It took place in more than 30 communities across Wisconsin, with all participants uniting at UW Stevens Point for the State Summer Games Opening Ceremony. On June 7, 2018, local law enforcement ran and biked through Sheboygan, Kohler, Sheboygan Falls, Plymouth, and Elkhart Lake with a special stop at Trooper Trevor Casper's grave in Kiel, with their final destination being the Special Olympics Wisconsin State Summer Games.

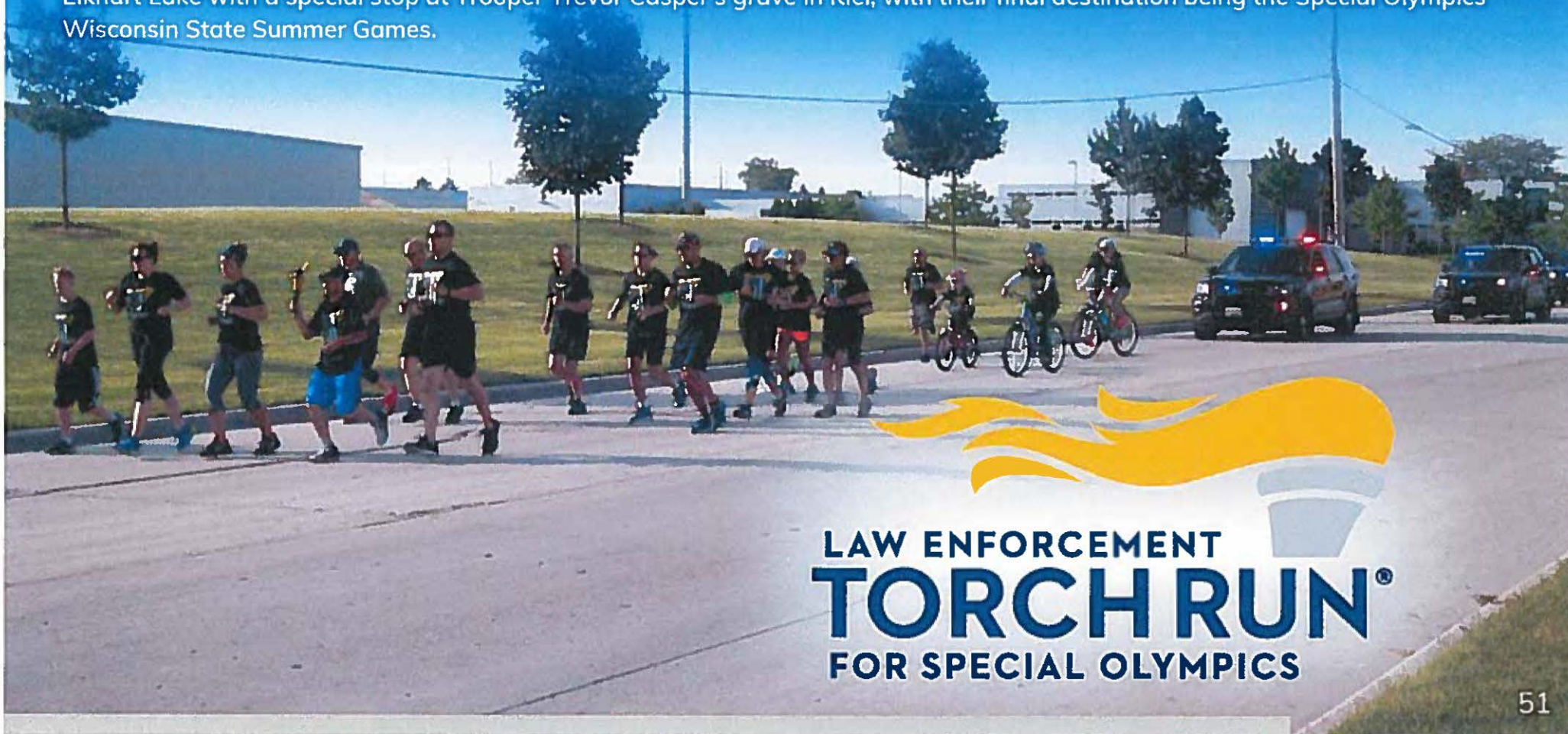

**LAW ENFORCEMENT
TORCH RUN®
FOR SPECIAL OLYMPICS**

Cop on a Rooftop

Wisconsin Law Enforcement Officers from around the state volunteered at Dunkin' Donuts locations on August 17, 2018 to support the Law Enforcement Torch Run for Special Olympics Wisconsin. In return for the police officers "doing time" at their restaurants, Dunkin' Donuts will donate \$5,000 to the organization.





Boo with the Blue

"Boo with the Blue" was a great success as officers and kids had Halloween fun together at the Boys and Girls Club of Sheboygan County on October 28, 2018.



Shop With A Cop

Shop With A Cop is an area law enforcement officer outreach where underprivileged children, who are referred to the program by social agencies, are paired up with an officer for an evening of food, fun and Christmas shopping for his or her family. Special thanks to local law enforcement volunteers, Lakeshore Lanes, Target and many community members who made this event possible. It is an incredible honor to be involved with these children and families.



The 3rd Annual Operation Blue Santa

The Sheboygan Police Department would like to thank all the great community sponsors that made this event possible. Christmas is a time for giving and we are so fortunate to be a part of this great event. The smiles on the children's faces were priceless! We hope that everyone involved remembers this for years to come.

Celebrating Success

The 2018 Sheboygan Police Benevolent
Association Service Awards



2018
Sheboygan
Police
Benevolent
Association
Service Awards



March 22nd, 2018
The Berkshire

The Service Awards recipients were nominated by fellow officers, supervisors and civilian co-workers. They represent those who strive to go above and beyond what is expected of them by their peers and the public. These men and women...our co-workers, friends and family members...did not ask to be put in heroic situations, but rather found themselves in circumstances that allowed them to demonstrate the qualities of a hero.



**Civilian Employee
of the Year:**

Presented to a non-sworn employee for exemplary service to the community, performance and achievement above and beyond that which is required by the employee's basic assignment.



Christin Koenig

**Police Officer of the
Year:**

Presented to an officer for exemplary service to the community, which involves performance and achievement above and beyond that which is required by an officer's basic assignment.



Detective Paul Olsen

2018
Sheboygan
Police
Benevolent
Association
Service Awards



March 22nd, 2018
The Berkshire



**Community
Engagement Award:**

Presented to individuals who demonstrated outstanding performance in community outreach and engagement and recognize initiatives which show potential for long-term impact on the community and its relationship with the Sheboygan Police Department.



Sheboygan Police Department Explorer Post 2881

**Meritorious
Service Award:**

Presented to an officer for exceptional performance of outstanding service on behalf of the department, while carrying out an act of great responsibility, or of critical importance to law enforcement.



Officer Mike Thielke

2018
Sheboygan
Police
Benevolent
Association
Service Awards



March 22nd, 2018
The Berkshire



**Citizen's
Distinguished
Service Award:**

Presented to individuals, who are not members of the police department, who through courageous acts of bravery and/or personal risk have assisted in apprehending a criminal, aiding an officer during a critical incident, or who demonstrated exceptional cooperation with the department in the accomplishment of its mission.

Not Pictured:
Lorrie Ruiz

Life Saving Award:

Presented to sworn and/or non-sworn individuals for performing an act, through prompt and decisive action, under extraordinary circumstances, that saves or significantly prolongs the life of another.



Officer Cody Griebing

The background of the slide is a close-up, slightly blurred image of the American flag, showing the stars and stripes in shades of blue, white, and red. The flag is draped and appears to be waving slightly.

Thanks!

We want to end our year in review by expressing our gratitude to our many community partners for their donations.

Bank First National

Bemis

Dutchland Plastics

Freaktoyz

Home Depot

Jean Grade

Just Kids Dental

KJH Enterprises of Sheboygan, Inc.

Old Wisconsin

Olivu 426, LLC

Playdium

Sheboygan Jaycees

Sheboygan Professional Police Officers' Supervisory Association

The Game Board

Vidya Stolz

Thank you

For your support
in 2018

Andrew and Barb Lindsay
Appraisal Compliance Review, Inc.
Automation Products
Barbara Kurten
Beth Ackley
Bill and Carol Stephen
Bitter Neumann
Bonnie Miller
Colin Mauthe
Crystal Michaels
Culver's Restaurant
Cynthia Zajac
Daniel and Anne Radtke
David Derus
David Dunn
Dean and Susan Loudon
Debi Mannchen
Dick and Nancy Johnsen
Edwin and Kathleen Siech
Dowsky's Raw Dawg Pet Foods
Edwin and Kathleen Siech
Erik and Mary Tanck
Firestone Complete Auto Care
Gerald and Astor Vatland
Indiana Corridor Neighborhood
Jane Schmelter
Jeanine Schrameyer
Jeffrey and Michelle Gentine
John Schoen
Joshua and Theresa Andrews
Joyce Onken
Julie Bell

Kaltenbrun Bros. Roofing Co., Inc.
King Park Neighborhood
Legend Larry's
Leick Furniture, Inc.
Lennen Liam Helgeson
Linda Van Ess
Lisa Tanck
Lt. Col. Marvin Roeber
Luken's Excavating
Mark Doss
Marlys Ziegelbauer
Mary Lewis
MaryLou Rammer
Michael and Terri Barber
Michael Curry
Mike and Nicole
Muth Mirror Systems
Nancy Devaney
Nicholas Shepard
Old Wisconsin
Pamela Oehldrich
Parkside Family Restaurant
Pigeon River Rec Center
Rogene Leick
Ryan Wessels
Sandra Robbins Pelisek
Schwarz Fish Company
Sheboygan Area Credit Union
Sheboygan Lutheran High School
Sheboygan Medical Arts Group
Sheboygan Noon Lions
Sheboygan Pine Club

Thank you

For your support of the SPD K9 Fund

Sheboygan Professional Police Officers' Association
Sheboygan Professional Police Officers' Supervisory Association
Sherry and Jon Bednarski
Shirlee and Darrell Lugg
Shoreline Woman's Club
Sue Stange
Susan K.A. de Shazer
Theodore Bergstrom
Timm Kraemer
Targinol, Inc.
Troy Miller
UAW Local 833
Van Horn Auto Group
Victorian Chocolate Shoppe
Vida Stolz
Virginia Radtke
Walmart
Wanda Whitham
Wesley and Darlene Hasseler
Zimmer Funeral Homes





SPD ANNUAL REPORT 2018

The Sheboygan Police Department's 2018 Annual Report was produced by Paula Haelfrisch, Mary Danen and Cassandra Wohlgemuth.

Special thanks to all those who submitted information to make this report possible and to Detective Paul Olsen for many of the beautiful photos.

Sheboygan Police Department
1315 N. 23rd Street, Suite 101
Sheboygan, WI 53081
(920)459-3333
sheboyganpolice.com



The SPD utilizes the following social media venues to disseminate information to the public; Nixle, Twitter, Nextdoor, Facebook and You Tube. Nixle is a community information system that is available via email, your cell phone by text message, and over the web via Twitter and Facebook.

VII

R. C. No. _____ - 18 - 19. By LICENSING, HEARINGS, AND PUBLIC SAFETY COMMITTEE. March 4, 2019.

Your Committee to whom was referred, pursuant to R. O. No. 222-18-19 by City Clerk submitting various license applications; recommends that the following licenses be granted with various caveats:

BEVERAGE OPERATOR'S LICENSE (NEW) (June 30, 2020)

<u>No.</u>	<u>Name</u>	<u>Address</u>
2600	Bush, Beth A.	1910 N. 28 th Street
2599	Guerra, Madeline N.	730 S. 8 th Street
8604	Hildreth, Ammber L.	2311 Hillshire Drive
2598	Lara-Ruiz, Carley J.	1708 N. 13 th Street
4182	Lee, Jollene C.	427 Wisconsin Avenue
2605	Looby Jr., Kevin S.	1620 Alexander Court
2608	Noss, Shane M.	2102 Calumet Drive, New Holstein
2597	Perry Harbert, Nyeim M.	3501 Lakeshore Road Apt. 2C
0661	Vanic, Patrick R.	1205 Stonebridge Drive, Howards Grove
2609	Wildman, Jonathan J.	711 Broadway Avenue
2593	Yonan, Keith S.	1614 Fox Hill Road

TAXICAB DRIVERS LICENSE (NEW) (December 31, 2019)

<u>No.</u>	<u>Name</u>	<u>Address</u>
2611	Kristoff, Seth M.	N3481 E Highway A, Sheboygan Falls
0565	Krueger, Nathan J.	13 S. Hiawatha Circle
2434	Lopez, Angela M.	4403 Primrose Court Apt. M101

"CLASS B" LIQUOR LICENSE (NEW) (June 30, 2019)

<u>No.</u>	<u>Name</u>	<u>Address</u>
*3325	Power Pubs, LLC	726 Kiwanis Park Drive
3353	Rendez-Vous	920 Michigan Avenue

*Contingent upon Power Pubs, LLC getting permission to sell wine or other liquor per the contract with the City.

Consent

CLASS "A" LIQUOR LICENSE (June 30, 2019) (NEW)

<u>No.</u>	<u>Name</u>	<u>Address</u>
3381	Meijer Store #305	924 North Taylor Drive

CLASS "A" BEER LICENSE (June 30, 2019) (NEW)

<u>No.</u>	<u>Name</u>	<u>Address</u>
3382	Meijer Gas Station #305	902 North Taylor Drive

_____ Committee

I HEREBY CERTIFY that the foregoing Committee Report was duly accepted and adopted by the Common Council of the City of Sheboygan, Wisconsin, on the _____ day of _____, 20____.

Dated _____ 20____, _____, City Clerk

Approved _____ 20____, _____, Mayor

VIII

R. C. No. _____ - 18 - 19. By PUBLIC WORKS COMMITTEE. March 4, 2019.

Your Committee to whom was referred Res. No. 175-18-19 by Alderpersons Wolf and Sorenson authorizing the appropriate City officials to enter into a contract for the Mead Public Library Plaza renovation project; recommends approving the Resolution.

Consent

_____ Committee

I HEREBY CERTIFY that the foregoing Committee Report was duly accepted and adopted by the Common Council of the City of Sheboygan, Wisconsin, on the _____ day of _____, 20____.

Dated _____ 20____, _____, City Clerk

Approved _____ 20____, _____, Mayor

III

4.1

Res. No. 175- 18 - 19. By Alderpersons Wolf and Sorenson.
February 18, 2019.

A RESOLUTION authorizing the appropriate City officials to enter into a contract for the Mead Public Library Plaza renovation project.

WHEREAS, pursuant to Resolution No. 162-18-19, the Engineering Division of the Department of Public Works has advertised for bids for the Mead Public Library Plaza renovation project; and

WHEREAS, two bids were received in response to that advertisement; and

WHEREAS, the bids were from:

Mike Koenig Construction Co. Inc. \$637,310.39
Jos. Schmitt & Sons Construction \$638,150.01; and

WHEREAS, the City Engineer has reviewed the bids and determined that the low bid, from Mike Koenig Construction Co. Inc., met all of the specifications.

NOW, THEREFORE, BE IT RESOLVED: That the appropriate City officials are hereby authorized to enter into the attached contract with Mike Koenig Construction Co. Inc. for the Mead Public Library Plaza renovation project in the amount of \$637,310.39 and are authorized to draw funds from the following accounts:

TID 16-Land Improvements	42661100-611200	\$400,000.00
2019 CDBG-Improvements Other Than Buildings	21961100-631100	\$237,310.39

Public Works approve

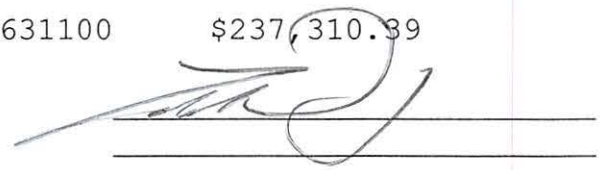

I HEREBY CERTIFY that the foregoing Resolution was duly passed by the Common Council of the City of Sheboygan, Wisconsin, on the _____ day of _____, 20____.

Dated _____ 20____, _____, City Clerk

Approved _____ 20____, _____, Mayor

**AGREEMENT
BETWEEN OWNER AND CONTRACTOR
FOR CONSTRUCTION CONTRACT (STIPULATED PRICE)**

THIS AGREEMENT is by and between City of Sheboygan ("Owner") and _____ ("Contractor").

Owner and Contractor hereby agree as follows:

ARTICLE 1 – WORK

1.01 Contractor shall complete all Work as specified or indicated in the Contract Documents. The Work is generally described as follows: Improvements to the Mead Public Library Plaza

ARTICLE 2 – THE PROJECT

2.01 The Project, of which the Work under the Contract Documents is a part, is generally described as follows: Concrete Sidewalk, Concrete Walls, Concrete Curb and Gutter, Asphalt Pavement, Area Lighting and Landscaping.

2.02 City of Sheboygan Resolution: _____

2.03 City of Sheboygan Account Number: _____

ARTICLE 3 – ENGINEER

3.01 The part of the Project that pertains to the Work has been designed by Ayres and Associates, Inc., Madison, WI, Engineer's Consultant.

3.02 The Engineering Division, Department of Public Works, City of Sheboygan, Sheboygan, WI will assume all duties and responsibilities, and have the rights and authority assigned to Engineer in the Contract Documents in connection with the completion of the Work in accordance with the Contract Documents.

If ENGINEER is undesignated, OWNER shall assume the duties and responsibilities of ENGINEER through OWNER's Director of Public Works (DPW), or the DPW's designee.

ARTICLE 4 – CONTRACT TIMES

4.01 *Time of the Essence*

A. All time limits for Milestones, if any, Substantial Completion, and completion and readiness for final payment as stated in the Contract Documents are of the essence of the Contract.

4.02 *Contract Times: Dates*

A. The work will be substantially complete within 70 working days after the date when Contract Times commence to run as provided in Paragraph 4.01 of the General Conditions, but no later than August 16, 2019, and completed and ready for final payment in accordance with Paragraph 15.06 of the General Conditions on or before the 14th day following substantial completion.

4.03 Liquidated Damages

- A. Contractor and Owner recognize that time is of the essence as stated in Paragraph 4.01 above and that Owner will suffer financial and other losses if the Work is not completed and Milestones not achieved within the times specified in Paragraph 4.02 above, plus any extensions thereof allowed in accordance with the Contract. The parties also recognize the delays, expense, and difficulties involved in proving in a legal or arbitration proceeding the actual loss suffered by Owner if the Work is not completed on time. Accordingly, instead of requiring any such proof, Owner and Contractor agree that as liquidated damages for delay (but not as a penalty):
1. Substantial Completion: Contractor shall pay Owner the amount identified in paragraph 19.01 of the Supplementary Conditions for each day that expires after the time (as duly adjusted pursuant to the Contract) specified in Paragraph 4.02.A above for Substantial Completion until the Work is substantially complete.
 2. Completion of Remaining Work: After Substantial Completion, if Contractor shall neglect, refuse, or fail to complete the remaining Work within the Contract Times (as duly adjusted pursuant to the Contract) for completion and readiness for final payment, Contractor shall pay Owner the amount identified in paragraph 19.01 of the Supplementary Conditions for each day that expires after such time until the Work is completed and ready for final payment.
 3. Liquidated damages for failing to timely attain Substantial Completion and final completion are not additive and will not be imposed concurrently.
 4. Milestones: Contractor shall pay Owner the amount identified in paragraph 19.01 of the Supplementary Conditions for each day that expires after the time (as duly adjusted pursuant to the Contract) specified above for achievement of Milestone 1, until Milestone 1 is achieved.

4.04 Special Damages

- A. In addition to the amount provided for liquidated damages, Contractor shall reimburse Owner (1) for any fines or penalties imposed on Owner as a direct result of the Contractor's failure to attain Substantial Completion according to the Contract Times, and (2) for the actual costs reasonably incurred by Owner for engineering, construction observation, inspection, and administrative services needed after the time specified in Paragraph 4.02 for Substantial Completion (as duly adjusted pursuant to the Contract), until the Work is substantially complete.
- B. After Contractor achieves Substantial Completion, if Contractor shall neglect, refuse, or fail to complete the remaining Work within the Contract Times, Contractor shall reimburse Owner for the actual costs reasonably incurred by Owner for engineering, construction observation, inspection, and administrative services needed after the time specified in Paragraph 4.02 for Work to be completed and ready for final payment (as duly adjusted pursuant to the Contract), until the Work is completed and ready for final payment.

ARTICLE 5 – CONTRACT PRICE

- 5.01 Owner shall pay Contractor for completion of the Work in accordance with the Contract Documents the amounts that follow, subject to adjustment under the Contract:

- A. For all Work, at the prices stated in Contractor's Bid, attached hereto as an exhibit.

ARTICLE 6 – PAYMENT PROCEDURES

6.01 *Submittal and Processing of Payments*

- A. Contractor shall submit Applications for Payment in accordance with Article 15 of the General Conditions. Applications for Payment will be processed by Engineer as provided in the General Conditions.

6.02 *Progress Payments; Retainage*

- A. Owner shall make progress payments on account of the Contract Price on the basis of Contractor's Applications for Payment on or about the 1st day of each month during performance of the Work as provided in Paragraph 6.02.A.1 below, provided that such Applications for Payment have been submitted in a timely manner and otherwise meet the requirements of the Contract. All such payments will be measured by the Schedule of Values established as provided in the General Conditions (and in the case of Unit Price Work based on the number of units completed) or, in the event there is no Schedule of Values, as provided elsewhere in the Contract.

1. Prior to Substantial Completion, progress payments will be made in an amount equal to the percentage indicated below but, in each case, less the aggregate of payments previously made and less such amounts as Owner may withhold, including but not limited to liquidated damages, in accordance with the Contract
 - a. 95 percent of Work completed (with the balance being retainage). If the Work has been 50 percent completed as determined by Engineer, and if the character and progress of the Work have been satisfactory to Owner and Engineer, then as long as the character and progress of the Work remain satisfactory to Owner and Engineer, there will be no additional retainage; and
 - b. 0 percent of cost of materials and equipment not incorporated in the Work (with the balance being retainage).

- B. Upon Substantial Completion, Owner shall pay an amount sufficient to increase total payments to Contractor to 100 percent of the Work completed, less such amounts set off by Owner pursuant to Paragraph 15.01.E of the General Conditions, and less 200 percent of Engineer's estimate of the value of Work to be completed or corrected as shown on the punch list of items to be completed or corrected prior to final payment.

6.03 *Final Payment*

- A. Upon final completion and acceptance of the Work in accordance with Paragraph 15.06 of the General Conditions, Owner shall pay the remainder of the Contract Price as recommended by Engineer as provided in said Paragraph 15.06.

ARTICLE 7 – INTEREST

- 7.01 All amounts not paid when due shall bear interest at the rate of 0 percent per annum.

ARTICLE 8 – CONTRACTOR’S REPRESENTATIONS

- 8.01 In order to induce Owner to enter into this Contract, Contractor makes the following representations:
- A. Contractor has examined and carefully studied the Contract Documents, and any data and reference items identified in the Contract Documents.
 - B. Contractor has visited the Site, conducted a thorough, alert visual examination of the Site and adjacent areas, and become familiar with and is satisfied as to the general, local, and Site conditions that may affect cost, progress, and performance of the Work.
 - C. Contractor is familiar with and is satisfied as to all Laws and Regulations that may affect cost, progress, and performance of the Work.
 - D. Contractor has carefully studied all: (1) reports of explorations and tests of subsurface conditions at or adjacent to the Site and all drawings of physical conditions relating to existing surface or subsurface structures at the Site that have been identified in the Supplementary Conditions, especially with respect to Technical Data in such reports and drawings, and (2) reports and drawings relating to Hazardous Environmental Conditions, if any, at or adjacent to the Site that have been identified in the Supplementary Conditions, especially with respect to Technical Data in such reports and drawings.
 - E. Contractor has considered the information known to Contractor itself; information commonly known to contractors doing business in the locality of the Site; information and observations obtained from visits to the Site; the Contract Documents; and the Site-related reports and drawings identified in the Contract Documents, with respect to the effect of such information, observations, and documents on (1) the cost, progress, and performance of the Work; (2) the means, methods, techniques, sequences, and procedures of construction to be employed by Contractor; and (3) Contractor’s safety precautions and programs.
 - F. Based on the information and observations referred to in the preceding paragraph, Contractor agrees that no further examinations, investigations, explorations, tests, studies, or data are necessary for the performance of the Work at the Contract Price, within the Contract Times, and in accordance with the other terms and conditions of the Contract.
 - G. Contractor is aware of the general nature of work to be performed by Owner and others at the Site that relates to the Work as indicated in the Contract Documents.
 - H. Contractor has given Engineer written notice of all conflicts, errors, ambiguities, or discrepancies that Contractor has discovered in the Contract Documents, and the written resolution thereof by Engineer is acceptable to Contractor.
 - I. The Contract Documents are generally sufficient to indicate and convey understanding of all terms and conditions for performance and furnishing of the Work.
 - J. Contractor’s entry into this Contract constitutes an incontrovertible representation by Contractor that without exception all prices in the Agreement are premised upon performing and furnishing the Work required by the Contract Documents.

ARTICLE 9 – CONTRACT DOCUMENTS

9.01 Contents

- A. The Contract Documents consist of the following:
 - 1. This Agreement (pages 00 52 00-1 to -[], inclusive).
 - 2. Performance bond (pages 00 61 13-1 to 00 61 13 - ____, inclusive).
 - 3. Payment bond (pages 00 61 14-1 to 00 61 14- ____, inclusive).
 - 4. General Conditions (EJCDC C-700, 2013 Edition) Supplementary Conditions, Specifications, and Drawings, not attached but incorporated by reference, as listed in the attached table of contents of the Project Manual.
 - 5. Addenda (not attached but incorporated by reference) (numbers 1 to -[], inclusive).
 - 6. Exhibits to this Agreement (enumerated as follows):
 - a. Contractor’s Bid (pages 1 to -[], inclusive).
 - 7. The following which may be delivered or issued on or after the Effective Date of the Contract and are not attached hereto:
 - a. Notice to Proceed,
 - b. Work Change Directives,
 - c. Change Orders,
 - d. Field Order,
 - e. Task Orders.
- B. The documents listed in Paragraph 9.01.A are attached to this Agreement (except as expressly noted otherwise above).
- C. There are no Contract Documents other than those listed above in this Article 9.
- D. The Contract Documents may only be amended, modified, or supplemented as provided in the General Conditions.

ARTICLE 10 – MISCELLANEOUS

10.01 Terms

- A. Terms used in this Agreement will have the meanings stated in the General Conditions and the Supplementary Conditions.

10.02 Assignment of Contract

- A. Unless expressly agreed to elsewhere in the Contract, no assignment by a party hereto of any rights under or interests in the Contract will be binding on another party hereto without the written consent of the party sought to be bound; and, specifically but without limitation, money that may become due and money that is due may not be assigned without such consent (except to the extent that the effect of this restriction may be limited by law), and unless specifically stated to the contrary in any written consent to an assignment, no assignment will release or discharge the assignor from any duty or responsibility under the Contract Documents.

10.03 Successors and Assigns

- A. Owner and Contractor each binds itself, its successors, assigns, and legal representatives to the other party hereto, its successors, assigns, and legal representatives in respect to all covenants, agreements, and obligations contained in the Contract Documents.

10.04 Severability

- A. Any provision or part of the Contract Documents held to be void or unenforceable under any Law or Regulation shall be deemed stricken, and all remaining provisions shall continue to be valid and binding upon Owner and Contractor, who agree that the Contract Documents shall be reformed to replace such stricken provision or part thereof with a valid and enforceable provision that comes as close as possible to expressing the intention of the stricken provision.

10.05 Contractor's Certifications

- A. Contractor certifies that it has not engaged in corrupt, fraudulent, collusive, or coercive practices in competing for or in executing the Contract. For the purposes of this Paragraph 10.05:
 - 1. "corrupt practice" means the offering, giving, receiving, or soliciting of any thing of value likely to influence the action of a public official in the bidding process or in the Contract execution;
 - 2. "fraudulent practice" means an intentional misrepresentation of facts made (a) to influence the bidding process or the execution of the Contract to the detriment of Owner, (b) to establish Bid or Contract prices at artificial non-competitive levels, or (c) to deprive Owner of the benefits of free and open competition;
 - 3. "collusive practice" means a scheme or arrangement between two or more Bidders, with or without the knowledge of Owner, a purpose of which is to establish Bid prices at artificial, non-competitive levels; and
 - 4. "coercive practice" means harming or threatening to harm, directly or indirectly, persons or their property to influence their participation in the bidding process or affect the execution of the Contract.

10.06 Other Provisions

- A. Owner stipulates that if the General Conditions that are made a part of this Contract are based on EJCDC® C-700, Standard General Conditions for the Construction Contract, published by the Engineers Joint Contract Documents Committee®, and if Owner is the party that has furnished said General Conditions, then Owner has plainly shown all modifications to the standard wording of such published document to the Contractor, through a process such as highlighting or "track changes" (redline/strikeout), or in the Supplementary Conditions.

(Continued on next page)

IN WITNESS WHEREOF, Owner and Contractor have signed this Agreement.

This Agreement will be effective on _____ (which is the Effective Date of the Contract).

OWNER:

CONTRACTOR:

City of Sheboygan

By: _____
(signature)

By: _____
(signature)

Name,
Title: Darrell Hofland , City Administrator

Name,
Title: _____
(printed)

Date: _____

Date: _____

(If Contractor is a corporation, a partnership, or a joint venture, attach evidence of authority to sign.)

Address for giving notices:

Address for giving notices:

City of Sheboygan - Engineering
2026 New Jersey Avenue
Sheboygan, WI 53081

License No.: _____
(where applicable)

Signed by:

Approved as to form and Execution:

By: _____
(signature)

By: _____
(signature)

Name,
Title: Michael Vandersteen, Mayor

Name,
Title: Charles C. Adams, City Attorney

Date: _____

Date: _____

Countersigned by:

By: _____
(signature)

Name,
Title: Meredith DeBruin, City Clerk

Date: _____

IX

R. C. No. _____ - 18 - 19. By LICENSING, HEARINGS, AND PUBLIC SAFETY COMMITTEE. March 4, 2019.

Your Committee to whom was referred Gen. Ord. No. 45-18-19 by Alderpersons Donohue, Dekker, Sorenson and Wolf amending Section 2-138 of the Municipal Code to provide that remote attendance would be included in the quorum count; recommends approving the Ordinance.

Consent

_____ Committee

I HEREBY CERTIFY that the foregoing Committee Report was duly accepted and adopted by the Common Council of the City of Sheboygan, Wisconsin, on the _____ day of _____, 20____.

Dated _____ 20____. _____, City Clerk

Approved _____ 20____. _____, Mayor

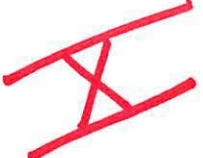

Gen. Ord. No. 45 - 18 - 19. By Alderpersons Donohue, Dekker, Sorenson and Wolf. February 18, 2019.

AN ORDINANCE amending Section 2-138 of the Municipal Code to provide that remote attendance would be included in the quorum count.

THE COMMON COUNCIL OF THE CITY OF SHEBOYGAN DO ORDAIN AS FOLLOWS:

Section 1. Section 2-138 of the Sheboygan Municipal Code entitled "Remote attendance at meetings" is amended in subsection (b) therein so as to read as follows:

"Sec. 2-138. Remote attendance at meetings.

. . .

(b) Quorum. A member who appears remotely pursuant to subsection (a) above shall count towards a quorum during said appearance.

. . ."

Section 2. All ordinances or parts thereof in conflict with the provisions of this ordinance are hereby repealed to the extent of such conflict, and this ordinance shall be in effect from and after its passage and publication.

Margaret Kerklin

John Sorenson

[Signature]

City Clerk approve

I HEREBY CERTIFY that the foregoing Ordinance was duly passed by the Common Council of the City of Sheboygan, Wisconsin, on the _____ day of _____, 20__.

Dated _____ 20____. _____, City Clerk

Approved _____ 20____. _____, Mayor

II

R. O. No. _____ - 18 - 19. By CITY CLERK. March 4, 2019.

Submitting a communication from Prohibition Bistro (Avni and Harry Latifi) requesting an encroachment into portions of Lot 1 Promenade, South Pier for the purpose of expanding the outdoor patio area.

CITY CLERK

City Plan

FEB 20 '19 PM 1:17

02/20/19

Prohibition Bistro
668 South Pier Drive
Sheboygan, WI 53081

RE: Request for Encroachment at Prohibition Bistro- Addition of Patio on West Side of Building

Common Council of City of Sheboygan:

My brother, Harry and I are going into our 6th year of business at Prohibition Bistro and really enjoy the great location on beautiful South Pier.

Right now, we have a small patio area on the west side of the building overlooking the river. We have found this patio has become quite popular during our peak seasons. To meet the needs of increased business and make use of the grassy area existing, we are requesting an encroachment to extend our outdoor serving area. The new area would be enclosed by 3 foot walls and paved with bricks.

By expanding the outdoor patio area, we would be able to accommodate more locals and increase tourist interest on South Pier.

In working with Sasha Moco of Moco Construction, we have included photos of the proposed addition.

Regards,



Avni Latifi

owner



**Encroachment Request
for
Prohibition Bistro 668 LLC**

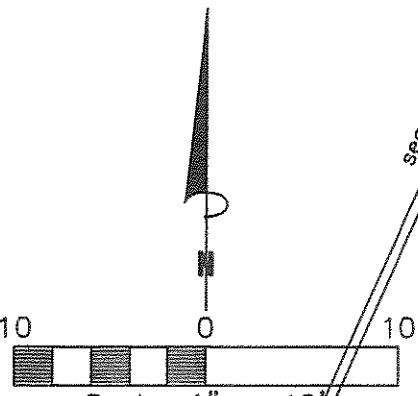

- = 1" iron pipe found
- ▲ = Large dia. nail found

Vertical Datum=City of Sheboygan
(Benchmark: Top of hydrant at
S. Pier Dr & Fisherman's Row, Elev 8.66)

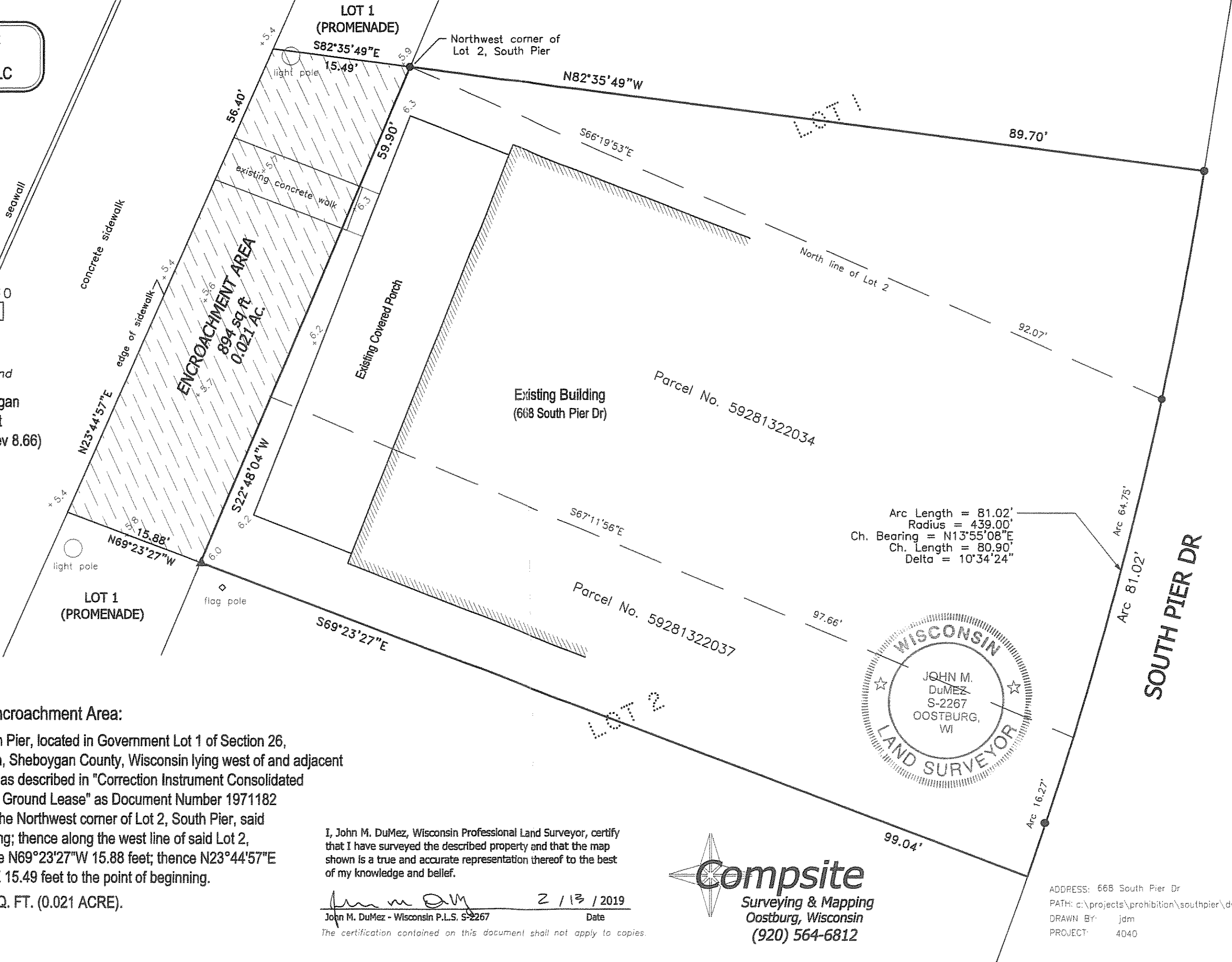

Description of Proposed Encroachment Area:

Part of Lot 1 Promenade, South Pier, located in Government Lot 1 of Section 26, T15N-R23E, City of Sheboygan, Sheboygan County, Wisconsin lying west of and adjacent to that part of Lot 2, South Pier as described in "Correction Instrument Consolidated and Restated Prohibition Bistro Ground Lease" as Document Number 1971182 described as: Commencing at the Northwest corner of Lot 2, South Pier, said point being the point of beginning; thence along the west line of said Lot 2, S22°48'04"W 59.90 feet; thence N69°23'27"W 15.88 feet; thence N23°44'57"E 56.40 feet; thence S82°35'49"E 15.49 feet to the point of beginning.

SAID AREA CONTAINS 894 SQ. FT. (0.021 ACRE).

I, John M. DuMez, Wisconsin Professional Land Surveyor, certify that I have surveyed the described property and that the map shown is a true and accurate representation thereof to the best of my knowledge and belief.

John M. DuMez 2/13/2019
 John M. DuMez - Wisconsin P.L.S. S-2267 Date
 The certification contained on this document shall not apply to copies.

Compsite
 Surveying & Mapping
 Oostburg, Wisconsin
 (920) 564-6812

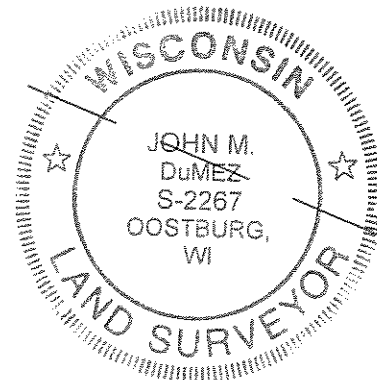

ADDRESS: 668 South Pier Dr
 PATH: c:\projects\prohibition\southpier\dwg\
 DRAWN BY: jdm
 PROJECT: 4040

II

R. O. No. _____ - 18 - 19. By CITY CLERK. March 4, 2019.

Submitting a claim from Zachory T. Felsinger for alleged damages to his vehicle when it was struck by a garbage truck.

CITY CLERK

Finance + Personnel

DATE RECEIVED 2-26-19

RECEIVED BY MKC. FEB 26 '19 PM 12:10

CLAIM NO. 29-18

CITY OF SHEBOYGAN NOTICE OF DAMAGE OR INJURY

INSTRUCTIONS: TYPE OR PRINT IN BLACK INK

- 1. Notice of death, injury to persons or to property must be filed not later than 120 days after the occurrence.
- 2. Attach and sign additional supportive sheets, if necessary.
- 3. This notice form must be signed and filed with the Office of the City Clerk.

4. TWO ESTIMATES MUST BE ATTACHED IF YOU ARE CLAIMING DAMAGE TO A VEHICLE.

- 1. Name of Claimant: Zachary T. Felsing
- 2. Home address of Claimant: 1746 N 9th street
- 3. Home phone number: (920) 377-6808
- 4. Business address and phone number of Claimant: _____

5. When did damage or injury occur? (date, time of day) 2-7-19 around 10 AM

6. Where did damage or injury occur? (give full description) Drivers side door, wheel well, panel inbetween door and front bumper, front bumper

7. How did damage or injury occur? (give full description) A garbage truck side swiped my car that was parked on the side of the road. The driver said he was attempting to back up.

8. If the basis of liability is alleged to be an act or omission of a City officer or employee, complete the following:

(a) Name of such officer or employee, if known: _____

(b) Claimant's statement of the basis of such liability: _____

9. If the basis of liability is alleged to be a dangerous condition of public property, complete the following:

(a) Public property alleged to be dangerous: _____

(b) Claimant's statement of basis for such liability: _____

DATE RECEIVED 2-26-19

RECEIVED BY MKC FEB 26 '19 PM 12:10

CLAIM NO. 29-18

CLAIM

Claimant's Name: Zachary J. Felsing
Claimant's Address: 1746 N 9th street
Claimant's Phone No. (920)-377-6808

Auto \$ 3,525.25
Property \$ _____
Personal Injury \$ _____
Other (Specify below) \$ _____
TOTAL \$ 3,525.25

PLEASE INCLUDE COPIES OF ALL BILLS, INVOICES, ESTIMATES, ETC.

WARNING: IT IS A CRIMINAL OFFENSE TO FILE A FALSE CLAIM.
(WISCONSIN STATUTES 943.395)

The undersigned hereby makes a claim against the City of Sheboygan arising out of the circumstances described in the Notice of Damage or Injury. The claim is for relief in the form of money damages in the total amount of \$ 3,525.25.

SIGNED [Signature] DATE: 2-26-19

ADDRESS: 1746 N 9th street

MAIL TO: CLERK'S OFFICE
828 CENTER AVE #100
SHEBOYGAN WI 53081

FEB 26 '19 PM 12:10

10. Give a description of the injury, property damage or loss, so far as is known at this time. (If there were no injuries, state "NO INJURIES").

No Injuries.

11. Name and address of any other person injured: _____

12. Damage estimate: (You are not bound by the amounts provided here.)

Auto: \$ 3,098.40 - \$3,525.25

Property: \$ _____

Personal injury: \$ _____

Other: (Specify below) \$ _____

TOTAL \$ 3,525.25

Damaged vehicle (if applicable)

Make: Hyundai Model: Sonata Year: 2012 Mileage: around 85k

Names and addresses of witnesses, doctors and hospitals: _____

FOR ALL ACCIDENT NOTICES, COMPLETE THE FOLLOWING DIAGRAM IN DETAIL. BE SURE TO INCLUDE NAMES OF ALL STREETS, HOUSE NUMBERS, LOCATION OF VEHICLES, INDICATING WHICH IS CITY VEHICLE (IF APPLICABLE), WHICH IS CLAIMANT VEHICLE, LOCATION OF INDIVIDUALS, ETC.

NOTE: If diagrams below do not fit the situation, attach proper diagram and sign.

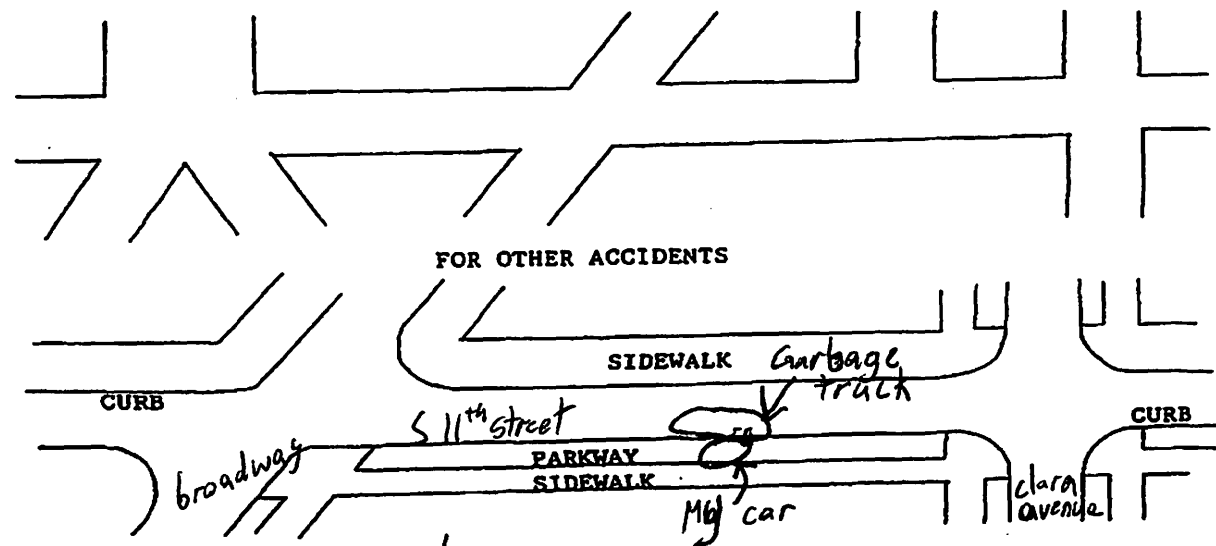

SIGNATURE OF CLAIMANT

[Handwritten Signature]

DATE

2-26-19

DEAN'S AUTO BODY INC
1407 N. 29TH STREET
SHEBOYGAN, WI 53081
OFFICE: 920-457-5494 FAX: 920-457-6495
"DEAN'S HAS THE MEANS FOR ALL YOUR AUTO NEEDS"

*** PRELIMINARY ESTIMATE ***

02/07/2019 01:41 PM

Owner

Owner: Zach Felsing
Address: 1746 N 9th St
City State Zip: Sheboygan, WI 53081
Email: zachoryfelsinger@gmail.com
Home/Day: (920)377-6808
Cell: (920)377-6808
FAX:

Inspection

Inspection Date: 02/08/2019 10:07 AM
Inspection Location: Dean's Auto Body
Address: 1407 North 29th St.
City State Zip: Sheboygan, WI 53081
Driveable: Yes
Inspection Type: Drive In
Contact: Phil Black
Work/Day: (920)457-5494x
FAX: (920)457-6495x
Rental Assisted:
Appraiser Name: PHIL BLACK
Appraiser License # :

Repairer

Repairer: Dean's Auto Body
Address: 1407 North 29th St.
City State Zip: Sheboygan, WI 53081
Contact: Phil Black
Work/Day: (920)457-5494
FAX: (920)457-6495

Target Complete Date/Time:

Days To Repair: 7*

Remarks

*** Original Estimate ***
*** Possible hidden damage open to further inspection ***
Possible clean up on used parts may be needed

Vehicle

2012 Hyundai Sonata Limited 4 DR Sedan
4cyl Gasoline 2.4
6-Speed Automatic

Lic.Plate: 478-ZYV
Lic Expire:
Prod Date: 08/2011
Veh Insp# :
Condition:
Ext. Color: RADIANT SILVER MET
Ext. Refinish: Two-Stage
Ext. Paint Code: SM

Lic State: WI
VIN: 5NPEC4AC4CH359727
Mileage: 84,659
Mileage Type: Actual
Code: E3174C
Int. Color:
Int. Refinish: Two-Stage
Int. Trim Code:

Options

2nd Row Head Airbags	AM/FM CD Player	Air Conditioning
Alarm System	Aluminum/Alloy Wheels	Amplifier
Anti-Lock Brakes	Auto Headlamp Control	Automatic Dimming Mirror
Auxiliary Audio Input	Bucket Seats	Center Console
Chrome Grille	Compact Spare Tire	Cruise Control
Daytime Running Lights	Driver Information Sys	Dual Airbags
Dual Zone Auto A/C	Electric Steering	Electronic Compass
Emergency S.O.S. System	Ext Mirror Turn Signals	Fog Lights
Garage Door Opener	Halogen Headlights	Head Airbags
Heated Frnt & Rear Seats	Heated Power Mirrors	High Definition Radio
IPOD Control	Illuminated Visor Mirror	Intermittent Wipers
Keyless Access System	Keyless Entry System	Keyless Ignition System
Leather Seats	Leather Shift Knob	Leather Steering Wheel
Lighted Entry System	MP3 Decoder	Overhead Console
Panorama Sunroof	Power Brakes	Power Door Locks
Power Drivers Seat	Power Windows	Pwr Accessory Outlet(s)
Pwr Driver Lumbar Supp	Rear Window Defroster	Rem Trunk-L/Gate Release
Side Airbags	Split Folding Rear Seat	Stability Cntrl Suspensn
Strg Wheel Radio Control	Subwoofer	Sunroof Wind Deflector
Tachometer	Theft Deterrent System	Tilt & Telescopic Steer
Tinted Glass	Tire Pressure Monitor	Traction Control System
Trip Computer	USB Audio Input(s)	Wireless Audio Streaming
Wireless Phone Connect	XM Satellite Radio	

Damages

Line	Op	Guide	MC	Description	MFR.Part No.	Price	ADJ%	B%	Hours	R
Front Bumper										
1	EC	33		Cover,Front Bumper >> >>Keystone Capa	Replace Economy	\$321.00*			2.6	SM
2	L	33	13	Cover,Front Bumper	Refinish 2.9 Surface 0.6 Two-stage setup 0.6 Two-stage				4.1	RF
3	E	48		Brkt,Front Bumper Mtg LT	865133S000	\$15.95			INC	SM
Front End Panel And Lamps										
4	RI	41		Headlamp Assy,Halogen LT	R & I Assembly				INC	SM
Front Body And Windshield										
5	EC	103		Fender,Front LT	Replace Economy	\$223.00*			2.5	SM
6	L	103		Fender,Front LT	Refinish 2.3 Surface 0.5 Edge 0.6 Two-stage				3.4	RF
7	TE	121		Guard,Fender Mud	Partial Replace Price	\$15.00				SM
8	ET	123		Guard,Fender Mud LT	Partial Replace Labor				INC	SM
Front Doors										
9	E	157		Lamp,Side Marker LT	876133Q000	\$157.02			0.4	SM
10	EU	207		Door Assembly,Front LT >> >>Rhine Auto	Replace Recycled	\$333.00*			2.0	SM
11	L	207		Door Shell,Front LT	Refinish 2.4 Surface 1.0 Edge 0.7 Two-stage				4.1	RF
12	RI	1127		Panel,Frnt Door Inner LT	R & I Assembly				INC	SM
13	RI	56		W/Strip,Front Door LT	R & I Assembly				0.5	SM

14	RI	231	Pnl,Inner Door Trim LT	R & I Assembly		INC	SM
15	RI	58	Mldg,Front Door Belt LT	R & I Assembly		0.2	SM
16	RI	257	Applique,Frt Door Fram LT	R & I Assembly		0.5	SM
17	RI	229	Mirror,Outer R/C LT	R & I Assembly		INC	SM
18	RI	215	Glass,Front Door T LT	R & I Assembly		INC	SM
19	RI	201	Channel,Front Glass Ru LT	R & I Assembly		1.5	SM
20	EU	358	Hinge,Front Door Upr LT	Replace Recycled	INC*	0.2	SM
21	L	358	Hinge,Front Door Upr LT	Refinish		0.4	RF
				0.3 Surface			
				0.1 Two-stage			
22	EU	213	Hinge,Front Door Lwr LT	Replace Recycled	INC*	0.2	SM
23	L	213	Hinge,Front Door Lwr LT	Refinish		0.4	RF
				0.3 Surface			
				0.1 Two-stage			
24	RI	252	Rod,Front Door Check LT	R & I Assembly		0.2	SM
25	RI	221	Lock,Front Door LT	R & I Assembly		0.2	SM
26	RI	241	Handle,Front Door Otr LT	R & I Assembly		INC	SM

Rear Doors

27	BR	289	Pnl,Rear Door Outer LT	Blend Refinish		1.3	RF
				0.9 Blend			
				0.4 Two-stage			
28	RI	1223	Panel,Rear Door Inner LT	R & I Assembly		0.3	SM
29	RI	237	Mldg,Rear Door Belt LT	R & I Assembly		0.8	SM
30	RI	307	Pnl,Inner Door Trim LT	R & I Assembly		INC	SM
31	RI	425	Handle,Rr Door Outer LT	R & I Assembly		0.2	SM

Manual Entries

32	L	M14	Corrosion Protection	Refinish		0.2*	RF	
33	EC		Cover car exterior	Replace Economy	\$5.00*	0.2*	SM	
34	EC		Flex Additive	Replace Economy	\$6.50*		RF	
35	N		De-Nib and polish	Additional Labor			SM*	
36	N		Hazad, waste	Additional Labor	\$5.00*		SM	
37	N		Transfer Door Parts	Additional Labor		2.0*	SM*	
			>> >>Transfer Original Door Parts & Wiring to Used Door. {Diff. Year}					
38	P		Brakes making noise	Check			SM*	
			>> >>Owner said that brakes are making noise {check at time of repairs}					
38	Items							

MC Message

13 INCLUDES 0.6 HOURS FIRST PANEL TWO-STAGE ALLOWANCE

Estimate Total & Entries

Gross Parts		\$187.97
Other Parts		\$893.50
Paint & Materials	13.9 Hours @ \$40.00	\$556.00
Parts & Material Total		\$1,637.47
Tax on Parts & Material	@ 5.500%	\$90.06

Labor	Rate	Replace Hrs	Repair Hrs	Total Hrs	
Sheet Metal (SM)	\$60.00	12.5	2.0	14.5	\$870.00
Mech/Elec (ME)	\$85.00				
Frame (FR)	\$75.00				
Refinish (RF)	\$60.00	13.9		13.9	\$834.00
Labor Total				28.4 Hours	\$1,704.00
Tax on Labor		@ 5.500%			\$93.72
Gross Total					\$3,525.25

Net Total

\$3,525.25

Alternate Parts Y/00/00/00/00/00 CUM 00/00/00/00/00 Zip Code: 53081 Default
Rate Name Default

Audatex Estimating 8.0.643 ES 02/08/2019 11:58 AM REL 8.0.643 DT 01/01/2019 DB 02/01/2019
© 2019 Audatex North America, Inc.

3.1 HRS WERE ADDED TO THIS ESTIMATE BASED ON AUDATEX'S TWO-STAGE REFINISH FORMULA.

MOTOR VEHICLE REPAIR PRACTICES ARE REGULATED BY CHAPTER ATCP 132, WIS.ADM.
CODE, ADMINISTERED BY THE BUREAU OF CONSUMER PROTECTION, WISCONSIN
DEPT. OF AGRICULTURE, TRADE AND CONSUMER PROTECTION, P.O. BOX 8911,
MADISON, WISCONSIN 53708-8911.

THIS ESTIMATE IS BASED ON OUR INSPECTION AND DOES NOT COVER ADDITIONAL PARTS
OR LABOR THAT MAY BE REQUIRED AFTER THE WORK HAS BEEN STARTED. OCCASIONALLY,
WORN OR DAMAGED PARTS ARE DISCOVERED THAT WERE NOT EVIDENT ON THE FIRST
INSPECTION. THEREFORE, THE ABOVE PRICED ARE NOT GUARANTEED. PARTS PRICES
SUBJECTED TO CHANGE DUE TO MANUFACTURER'S PRICE INCREASES.

Op Codes

- | | | |
|----------------------------|---|--------------------------------|
| * = User-Entered Value | ^ = Labor Matches System Assigned Rates | E = Replace OEM |
| NG= Replace NAGS | EC = Replace Economy | OE = Replace PXN OE Srpls |
| UE = Replace OE Surplus | ET = Partial Replace Labor | EP = Replace PXN |
| EU = Replace Recycled | TE = Partial Replace Price | PM = Replace PXN Reman/Rebit |
| UM = Replace Reman/Rebuilt | L = Refinish | PC = Replace PXN Reconditioned |
| UC = Replace Reconditioned | TT = Two-Tone | SB = Sublet Repair |
| N = Additional Labor | BR = Blend Refinish | I = Repair |
| IT = Partial Repair | CG = Chipguard | RI = R & I Assembly |
| P = Check | AA = Appearance Allowance | RP = Related Prior Damage |



This report contains proprietary information of Audatex and may not be disclosed to any third party (other than the insured, claimant and others on a need to know basis in order to effectuate the claims process) without Audatex's prior written consent.

© 2019 Audatex North America, Inc.
AUDATEX is a trademark owned by Audatex North America, Inc. All rights reserved.



SHEBOYGAN COLLISION CENTER
CHEVROLET - BUICK - GMC - CADILLAC INC
3400 SOUTH BUSINESS DRIVE - SHEBOYGAN, WI 53081
OFFICE: 920-459-6855 FAX: 920-459-6286 TOLL FREE: 888-459-6855
FED I.D.# 83-0747810 EMAIL: COLLISIONCENTER@SHEBOYGANAUTO.COM

*** PRELIMINARY ESTIMATE ***

02/19/2019 11:02 AM

Owner

Owner: ZACH FELSINGER
Address: 1746 N. 9TH ST
City State Zip: Sheboygan, WI 53081

Work/Day: (920)377-6808
FAX:

Inspection

Inspection Date: 02/19/2019 11:01 AM
Inspection Location: Sheboygan Chev/Buick/GMC/Cad
Address: 3400 SOUTH BUSINESS DRIVE
City State Zip: SHEBOYGAN, WI 53081
Email: collisioncenter@sheboyganauto.com
Primary Impact: Left Front Corner

Inspection Type:
Contact:
Work/Day: (920)459-6855x
Work/Day: (888)459-6855x
FAX: (920)459-6286x

Appraiser Name: PATRICK KARBE
Address: 3400 SOUTH BUSINESS DRIVE
City State Zip: Sheboygan, WI 53081
Email: collisioncenter@sheboyganauto.com

Secondary Impact:
Appraiser License # :
Work/Day: (920)459-6855
Work/Day: (888)459-6855
FAX: (920)459-6286

Repairer

Repairer: Sheboygan Chev/Buick/GMC/Cad
Address: 3400 SOUTH BUSINESS DRIVE
City State Zip: SHEBOYGAN, WI 53081
Email: collisioncenter@sheboyganauto.com

Contact:
Work/Day: (920)459-6855
Work/Day: (888)459-6855
FAX: (920)459-6286

Target Complete Date/Time:

Days To Repair: 8

Remarks

ESTIMATE OPEN FOR HIDDEN DAMAGES:
ORIGINAL / INITIAL ESTIMATE:
PRIOR DAMAGE TO LEFT FRONT WHEEL

Vehicle

2012 Hyundai Sonata Limited 4 DR Sedan
4cyl Gasoline 2.4
6-Speed Automatic

Lic.Plates: 478ZTV
Lic Expire:
Prod Date:
Veh Insp# :
Condition:

Lic State: WI
VIN: 5NPEC4AC4CH359727
Mileage: 85,010
Mileage Type: Actual
Code: E3174C

Ext. Color: RADIANT SILVER MET
Ext. Refinish: Two-Stage
Ext. Paint Code: SM

Int. Color: Gray
Int. Refinish: Two-Stage
Int. Trim Code: RA

Options - AudaVIN Information Received

2nd Row Head Airbags	AM/FM CD Player	Air Conditioning
Alarm System	Aluminum/Alloy Wheels	Amplifier
Anti-Lock Brakes	Auto Headlamp Control	Automatic Dimming Mirror
Auxiliary Audio Input	Bucket Seats	Cargo/Trunk Net
Center Console	Chrome Grille	Compact Spare Tire
Cruise Control	Daytime Running Lights	Driver Information Sys
Dual Airbags	Dual Zone Auto A/C	Electric Steering
Electronic Compass	Emergency S.O.S. System	Ext Mirror Turn Signals
Floor Mats	Fog Lights	Garage Door Opener
Halogen Headlights	Head Airbags	Heated Frnt & Rear Seats
Heated Power Mirrors	High Definition Radio	IPOD Control
Illuminated Visor Mirror	Intermittent Wipers	Keyless Access System
Keyless Entry System	Keyless Ignition System	Leather Seats
Leather Shift Knob	Leather Steering Wheel	Lighted Entry System
MP3 Decoder	Mud/Splash Guards	Overhead Console
Panorama Sunroof	Power Brakes	Power Door Locks
Power Drivers Seat	Power Windows	Pwr Accessory Outlet(s)
Pwr Driver Lumbar Supp	Rear Window Defroster	Rem Trunk-L/Gate Release
Side Airbags	Split Folding Rear Seat	Stability Cntrl Suspensn
Strg Wheel Radio Control	Subwoofer	Sunroof Wind Deflector
Tachometer	Theft Deterrent System	Tilt & Telescopic Steer
Tinted Glass	Tire Pressure Monitor	Traction Control System
Trip Computer	USB Audio Input(s)	Wireless Audio Streaming
Wireless Phone Connect	XM Satellite Radio	

AudaVIN options are listed in bold-italic fonts

Damages

Line	Op	Guide	MC	Description	MFR.Part No.	Price	ADJ% B%	Hours	R
<u>Stripes And Mouldings</u>									
1	RI	512		Mldg,Fender Side LT	R & I Assembly			0.2	SM
<u>Front Bumper</u>									
2	E	33	46	Cover,Front Bumper	865113Q000	\$384.14		1.8	SM
3	L	33	13	Cover,Front Bumper	Refinish			4.1	RF
					2.9 Surface				
					0.6 Two-stage setup				
					0.6 Two-stage				
4	E	7	46	Absorber,Front Energy	865203Q100	\$82.08		0.8	SM
5	E	48	46	Brkt,Front Bumper Mtg LT	865133S000	\$15.95		INC	SM
<u>Front Body And Windshield</u>									
6	I	103		Fender,Front LT	Repair			2.5*	SM
7	L	103		Fender,Front LT	Refinish			2.8	RF
					2.3 Surface				
					0.5 Two-stage				
8	TE	121		Guard,Fender Mud	Partial Replace Price	\$15.00		0.2*	SM
<u>Front Body Interior Sheetmetal</u>									
9	E	46	#	Skirt,Inner Fender LT	868113Q000	\$124.70		0.5	SM
				# = 01, 46					

Front Doors

10	RI	1799	Speaker,Front Door LT	R & I Assembly			0.2	SM
11	EU	207	46 Door Assembly,Front LT	Replace Recycled	\$300.00*	+25.00	3.0	SM
			>> TOM@CLEVELAND AUTO					
12	L	207	Door Shell,Front LT	Refinish			4.1	RF
				2.4 Surface				
				1.0 Edge				
				0.7 Two-stage				
13	RI	1127	Panel,Frt Door Inner LT	R & I Assembly			INC	SM
14	RI	215	Glass,Front Door T LT	R & I Assembly			1.0	SM
Rear Doors								
15	BR	289	Pnl,Rear Door Outer LT	Blend Refinish			1.3	RF
				0.9 Blend				
				0.4 Two-stage				
16	RI	237	Mldg,Rear Door Belt LT	R & I Assembly			0.8	SM
17	RI	425	Handle,Rr Door Outer LT	R & I Assembly			0.2	SM
Manual Entries								
18	L		Cover Car Exterior	Refinish	\$5.00*			SM
19	SB		Hazardous Waste	Sublet Repair	\$5.00*			RF*
20	L		Corrosion.Protection	Refinish	\$10.00*		0.2*	SM
21	L		Flex Additive	Refinish	\$6.00*			SM
21	Items							

MC Message

01	CALL DEALER FOR EXACT PART # / PRICE
13	INCLUDES 0.6 HOURS FIRST PANEL TWO-STAGE ALLOWANCE
46	PRINTABLE ALTERNATE PARTS COMPARE

Estimate Total & Entries

Gross Parts		\$621.87	
Other Parts		\$321.00	
Paint & Materials	12.3 Hours @ \$40.00	\$492.00	
Line Item Markup		\$75.00	
Parts & Material Total			\$1,509.87
Tax on Parts & Material	@ 5.500%		\$83.04
Labor	Rate	Replace	Repair Hrs
		Hrs	Total Hrs
Sheet Metal (SM)	\$60.00	8.9	2.5
Mech/Elec (ME)	\$120.00		
Frame (FR)	\$75.00		
Refinish (RF)	\$60.00	12.3	
			11.4
			12.3
			23.7 Hours
Labor Total			\$1,422.00
Tax on Labor	@ 5.500%		\$78.21
Sublet Repairs			\$5.00
Tax on Sublet	@ 5.500%		\$0.28
Gross Total			\$3,098.40
Net Total			\$3,098.40

Alternate Parts Y/05/00/00/05/04 CUM 05/00/00/05/04 Zip Code: 53081 Default
Recycled Parts NOT REQUESTED
Rate Name Default

Audatex Estimating 8.0.643 ES 02/19/2019 11:21 AM REL 8.0.643 DT 02/01/2019 DB 02/15/2019
© 2019 Audatex North America, Inc.

2.8 HRS WERE ADDED TO THIS ESTIMATE BASED ON AUDATEX'S TWO-STAGE REFINISH FORMULA.

THIS ESTIMATE HAS BEEN PREPARED BASED ON THE USE OF ONE OR MORE REPLACEMENT PARTS SUPPLIED BY A SOURCE OTHER THAN THE MANUFACTURER OF YOUR MOTOR VEHICLE. WARRANTIES APPLICABLE TO THESE REPLACEMENT PARTS ARE PROVIDED BY THE MANUFACTURER OR DISTRIBUTOR OF THE REPLACEMENT PARTS RATHER THAN BY THE MANUFACTURER OF YOUR MOTOR VEHICLE.

Op Codes

* = User-Entered Value	^ = Labor Matches System Assigned Rates	E = Replace OEM
NG = Replace NAGS	EC = Replace Economy	OE = Replace PXN OE Srpls
UE = Replace OE Surplus	ET = Partial Replace Labor	EP = Replace PXN
EU = Replace Recycled	TE = Partial Replace Price	PM = Replace PXN Reman/Rebld
UM = Replace Reman/Rebuilt	L = Refinish	PC = Replace PXN Reconditioned
UC = Replace Reconditioned	TT = Two-Tone	SB = Sublet Repair
N = Additional Labor	BR = Blend Refinish	I = Repair
IT = Partial Repair	CG = Chipguard	RI = R & I Assembly
P = Check	AA = Appearance Allowance	RP = Related Prior Damage



This report contains proprietary information of Audatex and may not be disclosed to any third party (other than the insured, claimant and others on a need to know basis in order to effectuate the claims process) without Audatex's prior written consent.

© 2019 Audatex North America, Inc.

AUDATEX is a trademark owned by Audatex North America, Inc. All rights reserved.



III

Res. No. _____ - 18 - 19. By Alderpersons Wolf and Donohue. March 4, 2019.

A RESOLUTION authorizing the appropriate City officials to sign the January 1, 2018-December 31, 2020 Contract between the City of Sheboygan and International Association of Firefighters Local 483.

WHEREAS, the January 1, 2018-December 31, 2020 Contract signed and dated February 22, 2019 reflects the terms in the Tentative Agreement between the parties which was previously ratified by the Common Council on December 17, 2018 via Res. No. 153-18-19.

NOW, THEREFORE, BE IT RESOLVED: That the Common Council hereby authorizes the appropriate City officials to sign the January 1, 2018-December 31, 2020 Contract between the City of Sheboygan and International Association of Firefighters Local 483, a copy of which is attached hereto and incorporated herein.

suspend & pass

I HEREBY CERTIFY that the foregoing Resolution was duly passed by the Common Council of the City of Sheboygan, Wisconsin, on the _____ day of _____, 20____.

Dated _____ 20____, _____, City Clerk

Approved _____ 20____, _____, Mayor

City of Sheboygan/Local 483 Contract

January 1, 2018 to December 31, 2020

Res. XXX-XX-XX

**CITY OF SHEBOYGAN
SHEBOYGAN, WISCONSIN**

January 1, 2018 – December 31, 2020

CONTRACT

**INTERNATIONAL ASSOCIATION OF FIREFIGHTERS
LOCAL 483**

City of Sheboygan/Local 483 Contract

January 1, 2018 to December 31, 2020

ARTICLE	TOPIC	PAGE NUMBER
AGREEMENT	4
ARTICLE I	RECOGNITION.....	5
ARTICLE II	UNION SECURITY.....	5
ARTICLE III	RIGHTS OF MANAGEMENT.....	6
ARTICLE IV	RESIDENCE REQUIREMENT.....	6
ARTICLE V	ARBITRATION CLAUSE.....	7
ARTICLE VI	DEFINITIONS.....	7
ARTICLE VII	NORMAL WORKWEEK.....	8
ARTICLE VIII	OVERTIME AND COMPENSATORY TIME.....	9
ARTICLE IX	PROMOTIONS AND TRANSFERS.....	17
ARTICLE X	GRIEVANCE PROCEDURE.....	24
ARTICLE XI	PROHIBITION OF STRIKES.....	28
ARTICLE XII	RULES AND REGULATIONS.....	30
ARTICLE XIII	LEAVES OF ABSENCE.....	31
ARTICLE XIV	BEREAVEMENT LEAVE WITH PAY.....	32
ARTICLE XV	BASE PAY AND LONGECITY PLAN.....	33
ARTICLE XVI	SALARY AND WAGE SCHEDULE.....	37
ARTICLE XVII	HOLIDAY PAY.....	39
ARTICLE XVIII	UNIFORM ALLOWANCE.....	40
ARTICLE XIX	SPECIAL SALARY PROVISIONS.....	41
ARTICLE XX	SEVERENCE PAY.....	46
ARTICLE XXI	VACATIONS.....	49
ARTICLE XXII	VACATION - FLSA AND REGULAR COMPENSATORY TIME-EMS DAY.....	50
ARTICLE XXIII	UNION ACTIVITIES.....	54
ARTICLE XXIV	MILITARY SERVICE.....	55
ARTICLE XXV	SICK LEAVE.....	56
ARTICLE XXVI	DUTY-INCURRED DISABILITY.....	60
ARTICLE XXVII	HEALTH INSURANCE.....	62
ARTICLE XXVIII	DENTAL INSURANCE.....	65
ARTICLE XXIX	LIFE INSURANCE.....	65
ARTICLE XXX	PENSIONS.....	66
ARTICLE XXXI	PHYSICALS.....	66
ARTICLE XXXII	LOSS OR DAMAGE.....	67
ARTICLE XXXIII	TIME TRADES.....	67
ARTICLE XXXIV	TRAINING.....	68
ARTICLE XXXV	NO OTHER AGREEMENT.....	69
ARTICLE XXXVI	SAVINGS CLAUSE.....	69
ARTICLE XXXVII	WAIVERS.....	69
ARTICLE XXXVIII	EMS.....	70
ARTICLE XXXIX	DURATION.....	71
ARTICLE XXXX	RETROACTIVITY.....	71
Letter of Intent	72
Signature Page	74
Exhibit A	Part Time Work Report.....	75
Addendum 1	Calculation examples.....	76
Addendum 2	Index.....	81
Addendum 3	Pay Schedules.....	84

City of Sheboygan/Local 483 Contract
January 1, 2018 to December 31, 2020

This page intentionally left blank

1 **AGREEMENT**

2
3 This Agreement, made and entered into at Sheboygan, Wisconsin, according to the provisions
4 of the Federal law and Section 111.70 and 111.71, Wisconsin Statutes, by and between the City
5 of Sheboygan, as municipal employer, hereinafter called the "City," and Local 483 of the
6 International Association of Firefighters, AFL-CIO, hereinafter called the "Union,"

7
8 **WITNESSETH:**

9 A. Both parties to this Agreement are desirous of reaching an amicable understanding with
10 respect to the employer-employee relationship that is to exist between them and enter
11 into an Agreement covering those matters primarily related to wages, hours, and
12 conditions of employment and those matters primarily related to management function
13 over which the employer has agreed to negotiate, as well as procedures for reducing
14 potential conflict with respect to such matters. Nothing in this provision would eliminate
15 the City's right to remove permissive subjects by law in successor contracts. In the event
16 of the City's exercising of this right, the union reserves its right to bargain the impact of
17 same with regard to its members' wages, hours and conditions of employment."

18
19 B. This Agreement shall be binding on the parties.

20
21 C. The material covered in this contract shall prevail and all ordinances and resolutions, or
22 parts of ordinances or resolutions contravening the provisions of this contract shall have
23 no effect insofar as the terms of this contract are concerned. Should any item not
24 covered in this contract be in question, Chapters fifteen (15) and twenty-nine (29) of the
25 Municipal Code shall be the next authority.

26
27 D. Section 62.13 of the Wisconsin Statutes and the authority vested in the office of the Fire
28 Chief by statutes shall not be preempted.

1 **ARTICLE III**

2 **RIGHTS OF MANAGEMENT**

3
4 A. The City acting through its officers, agents, and employees, retains all of the rights,
5 powers, and the authority exercised by it, its officers, agents, and employees prior to the
6 time that the Union became the collective bargaining representative of the employees
7 here represented, except as specifically limited by express provisions of this Agreement.

8
9 B. The Union agrees that it will not attempt to abridge this right.

10
11 C. The City agrees that the power, rights, and the authority herein claimed by the City are
12 not to be exercised in a manner that will undermine the Union or as an attempt to evade
13 the provisions of this Agreement or to violate the spirit, intent, or purposes of the
14 Agreement.

15
16 **ARTICLE IV**

17 **RESIDENCY REQUIREMENT**

18
19 Effective January 2016, all employees shall, within four (4) months of their completion of probation,
20 and as a condition of their employment, establish a permanent residence within 45 miles of the
21 jurisdictional boundaries of the City of Sheboygan, and must remain as residents within 45 miles of
22 the jurisdictional boundaries of the City of Sheboygan throughout their employment, except for the
23 following:

24
25 1. The Human Resources Director, with input and/or recommendation of the Fire Chief, may
26 extend the four (4) months to accommodate a hardship with evidence the employee is in the
27 process of securing residency.

28
29 2. Employees living outside the 45 miles of the jurisdictional boundaries of the City of Sheboygan
30 as of December 31, 2015 may continue to reside at the address of record on December 31,
31 2015. Any future change in address must not be further away from the current address on
32 record."

1
2
3
4
5
6
7
8
9
10
11
12
13
14
15
16

ARTICLE VII

NORMAL WORKWEEK

- A. Line firefighters of the Fire Department shall be scheduled for twenty-four (24) consecutive hours of duty. The normal work week shall be fifty-six (56) hours, but no employee shall be guaranteed any specific number of hours in any one (1) week.
- B. The specific alternating work schedule for line Firefighters shall be: work twenty-four (24) hours, off twenty-four (24) hours; work twenty-four (24) hours, off twenty-four (24) hours; work twenty-four (24) hours, off ninety-six (96) hours. This predetermined schedule shall prevail except in case of emergency when the hours shall be such as the Fire Chief or his/her designee deems proper for the fire protection and safety of the City.
- C. The Fire Chief may designate certain specially positions to a forty (40) hour week. The forty (40) hour week shall be eight (8) hour days, Monday through Friday, unless altered by mutual agreement amongst the Fire Chief, the Union, and the affected employee.

1
2
3
4
5
6
7
8
9
10
11
12
13
14
15
16
17
18
19
20
21
22
23
24
25
26
27
28
29
30
31

ARTICLE VIII

OVERTIME AND COMPENSATORY TIME

A. **Overtime Scheduling.** In emergencies, the Fire Chief or his/her designee may prescribe reasonable periods of overtime work or may call the off shift employees back to work to meet operational needs. Complete records of overtime of employees shall be maintained by the Fire Department and made available by the Fire Chief to the City Finance Director/Treasurer and Council as may be required.

B. **Overtime Compensation.** Compensation for overtime work shall be paid at the rate of one and one-half (1-1/2) times the regular biweekly rate of pay using the formula contained in each of the following sections:

1. **Fair Labor Standards Act Overtime Accrual - Compensatory Time.** All Fair Labor Standards Act overtime pay shall be accumulated as compensatory time off subject to the limits imposed by the Fair Labor Standards Act when the employee performs work in excess of two hundred four (204) hours in the twenty-seven (27) day work period established pursuant to Section 7K exemption of the Fair Labor Standards Act. Any employee who has accrued the maximum amount of compensatory time off, currently four hundred eighty (480) hours, shall, for additional overtime hours of work, be paid overtime compensation at the rate of one and one-half (1-1/2).

Fair Labor Standards Act compensatory time available to an employee shall be reflected by records kept by the City. Payment shall be paid to the bargaining unit member as overtime pay at the rate of one and one-half (1-1/2) for each hour of overtime worked on the last full pay period in December following its accrual, except insofar as such Fair Labor Standards Act overtime was compensated by compensatory time off.

Fair Labor Standards Act overtime may be taken out as compensatory time off at the rate of one (1) hour of time off for each hour of overtime earned.

City of Sheboygan/Local 483 Contract

January 1, 2018 to December 31, 2020

1 Personnel must decide by November 15th if they intend to use compensation time off or
2 receive cash for the remaining hours. Personnel may use accrued Fair Labor Standards
3 Act compensatory time off through March 31st of the year following the cash payout.
4 Hours not used by March 31st of said year will not be eligible for a cash payout. If
5 compensatory time is not exhausted by March 31st, management will assign time off by
6 May 31st with no less than one week notice unless mutually agreed between parties. Time
7 off assignments hereunder will not be counted toward the maximum number of bargaining
8 unit employees allowed off on approved leave of absence in accordance with Article XXII.
9

10 Fair Labor Standards Act overtime payments will accrue from the first twenty-seven
11 (27) day work period ending in July in a given year to the first twenty-seven (27) day
12 work period beginning in July of the following year with payment to be made on the
13 last full pay period of the year. Pay shall be calculated at the prevailing rate at the
14 time of payment using the following formula: regular biweekly pay divided by one
15 hundred twelve (112) x five-tenths (.5) x accrued hours.
16

17 Any holiday pay will not be used as an offset for overtime earned under the Fair
18 Labor Standards Act.
19

20 **2. Use of Compensatory Time Off.** Members of the bargaining unit who have
21 accumulated compensatory time off, exclusive of Fair Labor Standards Act
22 compensatory time off, shall be granted compensatory time off at the rate of one and
23 one-half (1-1/2) hours, or as required by law, for each hour of accumulated overtime
24 work in lieu of overtime cash payment. Compensatory time off is defined as
25 approved time off, in lieu of cash payment, during a scheduled work shift. Requests
26 for compensatory time off must be approved by the Fire Chief or his/her designee.
27 Compensatory time off will be granted if, in the opinion of the Fire Chief or his/her
28 designee, the department workload permits.
29

30 **3. Call Back.** An employee who has left his/her normal place of work for his/her
31 residence and is called back for an emergency shall receive a minimum credit of two
32 (2) hours. Any time worked in excess of the daily or weekly schedule shall be
33 credited on a straight-time basis, but is to be compensated at the time and one-half

1 (1-1/2) basis. The following formula shall be used for computing payment: regular
2 biweekly pay divided by eighty (80) x hours worked x one and one-half (1-1/2).
3 Accumulated overtime will be paid out on the first full pay period following such
4 accumulation.

5
6 4. **Extended Shift.** An on-duty employee who is required to remain on duty due to an
7 emergency in progress shall be paid at the time and one-half (1-1/2) rate or as
8 required by law, for all hours worked in excess of the daily work schedule. An
9 employee will receive a minimum of two (2) hours credit for extended shift overtime.
10 The following formula shall be used for computing payment: regular biweekly pay
11 divided by eighty (80) x hours worked x one and one-half (1-1/2). Accumulated
12 overtime will be paid out on the first full pay period following such accumulation.

13
14 5. **Stand-by.** An employee who is required to remain on duty for stand-by purposes
15 without an emergency in progress shall receive a minimum credit of two (2) hours
16 and shall be paid at the time and one-half (1-1/2) rate, or as required by law, for all
17 hours worked in excess of the daily work schedule. The following formula shall be
18 used for computing payment: regular biweekly pay divided by one hundred twelve
19 (112) x hours worked x one and one-half (1-1/2). Accumulated overtime will be paid
20 out on the first full pay period following such accumulation.

21
22 6. **Staffing Shortage.** Staffing shortage shall be defined as the need for additional
23 staffing to meet the minimum line firefighting staffing level of the department under
24 normal circumstances.

25
26 Staffing shortage records will be maintained by the office of the Fire Chief or his/her
27 designee.

28
29 All line Firefighters shall have their names placed, according to their current job
30 classification, on a "staffing shortage" list categorized by the following positions:
31 Officer, Fire Equipment Operator, Paramedic and Firefighter. New employees will be
32 placed on the Paramedic and/or Firefighter job classification list and assigned
33 overtime hours equal to the employee with the highest cumulative number of

1 overtime hours in any job classification. Upon promotion, the employee's name shall
2 be placed within the new job classification carrying over the cumulative number of
3 overtime hours worked from the previous job classification. If an employee changes
4 jobs and work schedules from a forty (40) hour to fifty-six (56) hour week, the
5 employee will be placed in the appropriate job classification and assigned overtime
6 hours equal to the employee with the highest cumulative total in the same job
7 classification.

8
9 *The following procedure will be used for staffing shortage call-in:*

10
11 (a) When a call-in is required, the Fire Chief or his/her designee will use the list for
12 the position needed to be filled, and the assignment will be made to that position.

13
14 (b) Overtime shall be offered to the individual with the lowest cumulative total of
15 overtime hours worked in the appropriate job classification. If two (2) or more
16 employees have an equal total of cumulative hours, seniority shall prevail.
17 Seniority shall be based on the departmental seniority list.

18
19 (c) If notification to the Battalion Chief necessitates an unanticipated call-in requiring
20 same-day (more than one hour notice) overtime call-in, the Battalion Chief shall
21 fill the need as soon as possible, moving down the list of available names without
22 hesitation. If the notification occurs during the business day before the day
23 required, or earlier, the Battalion Chief, may take a "little more time" to contact
24 the people on the list, using common sense and prudent judgment. For example,
25 the Battalion Chief may wait until the supper/dinner hour to start making the
26 telephone calls, being relatively sure that more people may be available at that
27 time.

28
29 If an immediate need for an employee call-in occurs (less than one hour notice), the
30 Fire Chief or his/her designee may use appropriate judgment to fill this need. That
31 judgment would include the employee's placement on the call-in list, location of an
32 employee's residence, the station where the vacancy exists, the time of day, the on-
33 coming shift assignments, and other pertinent information.

1
2 (d) For anticipated call-ins, the Fire Chief or his/her designee will attempt to contact
3 the employee using the telephone number supplied by the employee. If unable
4 to contact, a message will be left. If the Fire Chief or his/her designee is not re-
5 contacted by the employee by 9 a.m. the following morning, the next employee
6 will be contacted. If an employee declines the option for a call-in, the Fire Chief
7 or his/her designee shall contact the next employee on the appropriate list. The
8 Fire Chief or his/her designee is only responsible to attempt contact using the
9 telephone number supplied by the employee.

10
11 (e) In the event the list for a given job classification is depleted, another job
12 classification list may be used provided the employee called in is qualified for the
13 needed position. If the call-in is still unable to be filled, the Fire Chief or his/her
14 designee will order in the qualified employee with the least departmental seniority
15 in the needed job classification. Employees ordered in for staffing shortage
16 overtime will not have those hours added to his/her accumulated total overtime
17 hours list.

18
19 If in the event mandatory overtime is required again from that same job classification,
20 all previously mandated employees will be bypassed and the City will proceed to
21 order in the next least senior employee. This process continues as needed. This
22 system shall apply to all categories. The City has the authority to order in an
23 employee in any category to fill any vacancy when the City is unable to contact an
24 employee from the needed job classification. The city will not mandate any
25 employee on scheduled leave to accept involuntary overtime. Employees remain on
26 the list in case of a recurrence of mandatory overtime. Each calendar year, the
27 system starts anew.

28
29 (f) Employees on approved Family Medical Leave, jury duty, military leave,
30 approved school for workers leave, approved convention leave, bereavement
31 leave, sick leave, or worker's compensation on the date needed are not eligible
32 for call-in. Employees on approved vacation, EMS day, compensatory time
33 (FLSA or departmental), or on their day off are eligible for call-in.

1
2 (g) The new cumulative total of overtime hours will be recorded on the list when the
3 assignment is accepted. Once accepted, it is the employee's responsibility to
4 report to duty that day or make appropriate arrangements (trade, if necessary).
5

6 (h) In the event that the City cancels the accepted hours with more than forty-eight
7 (48) hours notice prior to the scheduled call-in, the Fire Chief or his/her designee
8 will notify the employee and make the appropriate adjustment to the records. In
9 the event that the City cancels the accepted hours with less than forty-eight (48)
10 hours notice prior to the scheduled call-in, the affected employee will receive two
11 (2) hours of overtime, provided the employee agrees to work the two (2) hours.
12 The employee must select the two (2) hours to be worked at the time of the
13 cancellation. The Fire Chief or his/her designee will make the appropriate
14 adjustment to the records.
15

16 (i) In the event that the City shortens the accepted hours of the scheduled call-in,
17 the Fire Chief or his/her designee will contact the employee and offer the hours
18 under the new circumstances. If the employee declines, the Fire Chief or his/her
19 designee will continue down the list using the normal procedure. In the event
20 that the City shortens the accepted hours after an employee has reported for
21 duty, the employee will receive a minimum of two (2) additional hours beyond the
22 shortened call-in time provided the employee agrees to work the two (2)
23 additional hours. The Fire Chief or his/her designee will make the appropriate
24 adjustment to the records.
25

26 (j) In the event an error is made regarding the use of the appropriate list, the Fire
27 Chief or his/her designee will notify the employee scheduled and cancel the
28 scheduled call-in. The appropriate list will then be used to fill the call-in. In the
29 event this occurs less than forty-eight (48) hours prior to the scheduled call-in,
30 the employee originally accepting the call-in will receive two (2) hours of
31 overtime, provided the employee agrees to work the two (2) hours. The
32 employee must select the two (2) hours to be worked at the time of the
33 cancellation. If the error is first noticed on the scheduled day of work or

1 thereafter, a switch to the appropriate list will be made at the next opportunity to
2 balance the error.

3
4 (k) An employee who is within two (2) months of retirement will be given the
5 opportunity to work total hours of a missed called-in (if the first overtime
6 opportunity does not occur at least two (2) months prior to the employee's
7 retirement date) provided the employee would have been given the overtime
8 under normal circumstances.

9
10 (l) Payment for staffing shortage overtime will be made at the time and one-half (1-
11 1/2) rate of the employee or as required by law. The following formula shall be
12 used for computing payment: regular biweekly pay divided by one hundred
13 twelve (112) x hours worked x one and one-half (1-1/2).

14
15 (m) Holidays. If an employee is called-in for a staffing shortage on a holiday named
16 in this contract, but not a floating holiday, the employee shall be paid by the
17 following formula rate for all hours worked: regular biweekly pay divided by one
18 hundred twelve (112) x hours worked x two (2). All pay under this subsection will
19 be paid out the first full pay period following its accumulation. A holiday in this
20 section shall be defined as 8 a.m. to 8 a.m.

21
22 7. **Additional Duty.** An off-duty employee requested to work on special non-
23 emergency assignments as designated by the Fire Chief will be paid on the time and
24 one-half (1-1/2) rate or as required by law. An employee will receive a minimum of
25 two (2) hours for additional duty overtime. The following formula shall be used for
26 computing payment: regular biweekly pay divided by one hundred twelve (112) x
27 hours worked x one and one-half (1-1/2) for fifty-six (56) hour per week employees,
28 and regular biweekly pay divided by eighty (80) x hours worked x one and one-half
29 (1-1/2) for forty (40) hour per week employees. Payment for overtime accumulated
30 under this subsection will be paid out on the first full pay period following its
31 accumulation, or the Fire Chief may grant compensation off in lieu of pay.

1 **8. Specialist (eight {8} hour employee) Overtime Compensation.**

2
3 A specialist shall have the following options for overtime earned:

4
5 (a) Upon request, receive overtime payment on the first full pay period following its
6 accumulation. The following formula shall be used for computing payment. Biweekly
7 pay divided by eighty (80) x one and one-half (1-1/2) x hours worked.

8
9 (b) Accumulated as compensatory time off in lieu of overtime cash payment.
10 Compensatory time off shall be granted at the rate of one and one-half (1-1/2) hours
11 for each hour worked. Requests for compensatory time off must be approved by the
12 Fire Chief or his/her designee. Compensatory time off will be granted if, in the option
13 of the Fire Chief or his/her designee, the department workload permits.

14
15 Such compensatory time accrual shall be accrued from November 1 through October 31 of
16 the following year. Any accrued compensatory time not entered, authorized, and approved
17 as of November 30 shall be paid on the last full pay period of the year. Pay shall be
18 calculated at the prevailing rate at the time of payment using the following formula:
19 biweekly pay divided by eighty (80) x one and one-half (1-1/2) x accrued hours.

20
21 **Exception to 8:**

22 A specialist working overtime on a holiday named in this contract shall receive double time
23 (biweekly pay divided by eighty (80) x two (2) x hours worked).

24
25 (c) **No Pyramiding, duplicating or compounding.** Application of the provisions
26 contained in this Article shall not involve pyramiding, duplicating, or compounding of
27 overtime.

1 **E. Fire Apparatus Driver/Operators and Fire Equipment Operators**

2
3 All employees hired after January 1, 2002 are required to be certified by the Sheboygan Fire
4 Department as Fire Apparatus Driver/Operators. The department shall provide a training
5 program to enable employees to become certified.

6
7 An employee must complete the Fire Apparatus Driver/Operator training program to be
8 certified and in order to receive the step four (4) increase. The Fire Department shall not
9 hinder an employee's participation in the certification process and will provide employees
10 ample opportunities to train so that they are able to be certified in a timely manner. If
11 certification occurs beyond the thirty sixth (36th) month of employment then upon certification
12 the employee's pay would be based on length of service with the department and future step
13 increases shall be based on the date of hire and not the date of certification.

14
15 To be eligible and qualified for promotion to Fire Equipment Operator (FEO), a certified Fire
16 Apparatus Driver/Operator must have previously successfully completed a written and
17 practical examination for FEO as established by the fire department. The most senior
18 qualified employee will be offered the FEO position. Declining the offer does not affect the
19 employee's eligibility for future openings.

20
21 At a minimum, the Department will provide the FEO written and practical testing annually;
22 however, when the need arises, the Department will provide the FEO written and practical
23 testing semiannually.

24
25 Employees will be informed of the expected standards for completion of the Fire Apparatus
26 Driver/Operator program as well as the expectations for successful completion of the written
27 and practical examinations for qualification for promotion. It is the responsibility of the
28 employee to provide the effort necessary to meet those standards and expectations. All new
29 FEOs shall be ranked using in-grade seniority based on the date of the promotion.*

30
31 *Firefighter Greg Wucherer shall be grandfathered. If/when he would be promoted to FEO, he
32 shall be ranked according to department seniority.

1 **Note -- These language changes are not intended to effect the status of the current FEO
2 eligibility list, it is only intended to spell out the process for any future additions to said list.**

3
4 F. **Eligibility lists** for the positions Captain and Lieutenant shall be established for a two
5 (2) year period. Lists for the positions, Captain and Lieutenant shall expire on March 1 of
6 the year in which new testing or qualification procedures are conducted. **EXCEPTION:**
7 In the event that the eligibility list in a class grade is exhausted prior to the expiration
8 date, a new promotional procedure will be conducted at the earliest convenient date
9 after a vacancy in a position occurs. If a vacancy occurs within forty-five (45) days prior
10 to the expiration of an eligibility list, and the eligibility list has been exhausted, the Fire
11 Department may postpone filling the vacancy until the regularly scheduled promotional
12 procedure is completed. Time in service requirements under this exception shall be
13 calculated from the date of hire to the first day of the month in which the vacancy
14 occurred.

15
16 The following circumstances will supersede the promotional eligibility lists:

- 17 1. An employee who has not passed a rank probationary period.
18 2. An employee has been demoted.
19 3. An employee has voluntarily chosen to transfer to an opening in a lower rank he
20 previously held.

21
22 Each applicant for the above positions will receive the following information in writing
23 within five (5) days of the establishment of the approved eligibility list or the first
24 appointment whichever occurs first.

- 25 1. A complete list of all cumulative scores.
26 2. His/her own scores both cumulative and per category.
27 3. His/her own ranking after seniority is applied.

28
29 The Union shall receive a written list of all qualified applicants within five (5) days of the
30 establishment of the approved eligibility list or the first appointment whichever occurs
31 first.

1 In the event that an employee on an eligibility list refuses a position when offered, such
2 employee's name will be removed from the eligibility list. Such employee shall submit
3 his/her notice in writing to the Fire Chief. Such employee will be required to re-qualify for
4 a future position.
5

6 **H. Transfers:** The Fire Chief will make whatever transfers are needed for the efficient
7 operation of the department. Lateral transfers made by the Fire Chief for the "efficient
8 operation of the department" will ordinarily take place during the months of January and
9 February. Employees involved in lateral transfers will be given a minimum of thirty (30)
10 day notice to allow these employees to adjust both professional and personal affairs.
11 Transfers may occur prior to the end of the thirty (30) day period upon the request of, or
12 with the concurrence of, the affected employee. Transfers may also be made at any time
13 on the basis of compelling department operational requirements, to include, but not
14 limited to, irreconcilable conflicts between employees assigned to the same station, as
15 part of a formal program of work performance improvement, or if recommended to an
16 employee as part of a program developed under the City Employee Assistance Program.
17 Transfers that take place other than during January or February shall be discussed with
18 the Union's Executive Board before being made.
19

20 Any qualified employee wishing to fill a vacancy caused by promotion, retirement or a
21 new position shall make his/her request to the Fire Chief or his/her designee. In the
22 event that two or more equally qualified Captains or Lieutenants request a lateral
23 transfer to fill a posted vacancy, the employee with the most seniority as applicable to
24 the position will be given preference unless it is deemed the efficient operation of the
25 department will be impaired. In the event that two or more equally qualified Fire
26 Equipment Operators or Firefighters request a lateral transfer to fill a posted vacancy,
27 the employee with the most department seniority will be given preference unless it is
28 deemed the efficient operation of the department would be impaired. The remaining
29 positions will be filled by the least senior employee. An employee of higher rank is also
30 eligible to apply for a posted vacancy of a lower rank provided that he/she has previously
31 served in the lower rank. Under this circumstance, seniority in grade will be equal to the
32 amount of time the employee previously served in the lower rank.

1 A request of an employee to return to a previously held rank may be honored by the Fire
2 Chief or his/her designee when no vacancy exists. Under this circumstance, seniority in
3 grade will be equal to the amount of time the employee previously served in the lower
4 rank.

5 An equally qualified member of the department may also request a lateral transfer to
6 another company during the months of January and February. All such requests are to
7 be honored unless it is deemed the efficient operation of the department would be
8 impaired.

9
10 **I. Probation**

11
12 1. All newly hired full-time employees shall serve a minimum probationary period of one
13 (1) year uninterrupted by any type of service break during which time they will be
14 termed probationary employees.

15
16 2. Probationary employee's service may be terminated at any time by the Fire Chief in
17 his/her sole discretion and the employee so terminated shall have no recourse over
18 such termination. Probationary employees receive temporary assignments.

19
20 3. Probationary employees may be transferred or rotated within various temporary
21 assignments at any time during probation. This will provide the greatest exposure to
22 fire personnel, apparatus, equipment, districts, and buildings, and to facilitate
23 training. Such transfers and rotations shall not adversely affect any FLSA
24 compensatory time credit that would have been earned had the transfer or rotation
25 not occurred.

26
27 4. After an employee has successfully completed his/her probationary period of
28 employment, he/she shall become a regular full-time employee and he/she shall be
29 placed on the seniority list as of his/her date of hire.

30
31 **J. Layoff and Recall**

32
33 1. When it becomes necessary, because of need for economy, lack of work or funds, or for

1 other just causes, to reduce the number of subordinates:

2
3 (a) the emergency, special, temporary, part-time, or provisional subordinates, if any,
4 shall be dismissed first, and thereafter subordinates shall be dismissed in the
5 order of the shortest length of service in the department, provided that, in cities
6 where a record of service rating has been established prior to January 1, 1933,
7 for the said subordinates, the emergency, special, temporary, part-time
8 provisional subordinates, if any, shall be dismissed first, and thereafter
9 subordinates shall be dismissed in the order of the least efficient as shown by the
10 said service rating.

11 (b) When it becomes necessary to reduce the number of subordinates in the higher
12 positions, or to abolish any higher positions in the department, the subordinate or
13 subordinates affected thereby shall be placed in a previous position in the
14 department less responsible according to his/her efficiency and length of service
15 in the department.

16
17 2. The name of a subordinate laid off as set forth in this section shall be left on an
18 eligible reemployment list for a period of five (5) years due to layoff. If an approved
19 vacancy occurs or if the number of subordinates is increased in the department, such
20 vacancy or new positions shall be filled by persons on such list in the inverse order of
21 the layoff of such persons provided they can pass a standard physical examination.

22
23 3. Any reduction in salaries of employees governed by the terms of this section shall be
24 in accordance with 62.13(7), Wisconsin Statutes.

25
26 4. For any employee who was laid off and then returns to employment, all affected
27 contractual pay/benefits/seniority for that employee shall be for the amount of time
28 served, even though it has not been continuous.

29
30 In the event that an employee is laid off for less than six (6) months and then returns to
31 employment, said employee will earn credited time during his/her absence despite having been
32 laid off for the following purposes: vacation, step increases, longevity increases, and time in
33 service for seniority.

1
2
3
4
5
6
7
8
9
10
11
12
13
14
15
16
17
18
19
20
21
22
23
24
25
26
27
28
29
30

K. Loss of Seniority:

1. An employee's seniority and employment shall terminate if:
 - (a) The employee quits, or
 - (b) The employee is discharged for just cause, or
 - (c) A settlement with the employee has been made for total disability, or
 - (d) The employee is retired, or
 - (e) The employee is laid off or has not, for any reason, worked for the department for a continuous period exceeding sixty (60) calendar months.

2. An employee may be subject to disciplinary action up to and including possible termination and/or loss of seniority if:
 - (a) The employee has not, for any reason other than those listed as (a) through (e) above, worked for the department for a continuous period exceeding twenty-four (24) calendar months, or
 - (b) An employee is absent from work without advising the Fire Chief or his/her designee acceptable to the department for such absence, or
 - (c) The employee overstays a leave of absence without advising the Fire Chief or his/her designee a reason acceptable to the department, or
 - (d) The employee gives a false reason in requesting a leave of absence or engages in other full time employment during such leave of absence, or
 - (e) The employee knowingly falsified information on his/her application for employment material to his/her employment status, or
 - (f) The employee holds another job wherein he/she is employed by another employer without specific written authorization therefore from the Fire Chief which written authorization shall be contained on a form similar to that attached hereto as Exhibit A.

1
2
3
4
5
6
7
8
9
10
11
12
13
14
15
16
17
18
19
20
21
22
23
24
25
26
27
28
29
30
31
32
33

ARTICLE X
GRIEVANCE PROCEDURE

A. **General Provisions:** A grievance under this Agreement is a written claim arising under and during the terms of this Agreement, initiated as set out below limited to the interpretation, application, or enforcement of the terms of this Agreement and disciplinary action except disciplinary action subject to Chapter 62.13 (i.e. involving suspension, reduction in rank, suspension and reduction in rank, or removal.) Any dispute with respect to the reasonableness of the application of work rules primarily related to working conditions, wages, or hours, except those that affect safety, firefighting, or activities related thereto, shall be subject to the grievance procedure.

B. **Items Exempt from Consideration** for Processing Under this Procedure include the following:

1. **Job classifications, promotional procedures** as are provided by Chapter 62, Wisconsin Statutes, or any other matter provided for in that statute except disciplinary action as defined herein. With regard to the foregoing matters, Chapter 62, Wisconsin Statutes, will apply rather than the grievance procedure.
2. **Pension matters** under the exclusive jurisdiction or control of any duly authorized pension board.

C. **Departure from the steps of the procedure** or change in time limits may be made with written permission of the Fire Chief or his/her designee upon request of either party when mutually agreed to by the Fire Chief and the aggrieved party and his/her representative.

D. **All grievances and grievance appeals shall set forth the provisions of the Agreement** and/or the rule or regulation of the Fire Chief under which the grievance was filed. All appeals of duly filed grievances not submitted by the Association or employee within the time limit specified shall be termed abandoned grievances and as such shall be considered as being resolved in favor of the City and not subject to further consideration under the provisions of this grievance and arbitration procedure. Properly

1 prepared and filed grievances shall be answered on behalf of the City within the time
2 limits specified; and in the event such grievances are not so answered, they shall be
3 termed abandoned grievances and as such shall be considered as being resolved in
4 favor of the Association or the employee. Abandoned grievances shall not be
5 considered precedent for future cases. By mutual agreement, the parties may waive any
6 of the steps contained in this grievance and arbitration procedure.

7
8 **E. Steps in the Grievance Procedure:**

- 9
10 1. The aggrieved employee and/or his/her Association steward shall, within ten (10)
11 calendar days of the date the alleged grievance occurred, submit the facts of the
12 grievance in writing, signed by the complainant, to the Fire Chief or his/her designee.
13 The Fire Chief or his/her designee shall, within ten (10) calendar days, reply to the
14 grieving party in writing giving his/her decision with a copy to the Fire Chief.
- 15 2. Should the Association grievance committee decide that the reply of the Fire Chief or
16 his/her designee is unsatisfactory, the Association shall within ten (10) calendar days
17 submit the facts of the grievance in writing to the Fire Chief or his/her designee with
18 a copy to the City Labor Negotiator. The Fire Chief and his/her designee shall within
19 ten (10) calendar days hold a meeting with the aggrieved employee, his/her
20 immediate supervisor, and no more than two (2) Association representatives that the
21 aggrieved employee shall wish in attendance. The Fire Chief or his/her designated
22 representative shall within ten (10) calendar days of the meeting furnish the
23 Association grievance committee his/her written response with a copy to the City
24 Labor Negotiator. In cases of discipline administered by the Fire Chief or his/her
25 duly authorized subordinate, the grievance shall be initiated at Step 2 of the
26 grievance procedure. Disciplinary action imposed by a duly designated subordinate
27 is subject to review of the Fire Chief; however, the Fire Chief reserves the right to
28 take official action without prejudice based upon his/her own findings. Decisions
29 made at any level below that of the Fire Chief shall not be interpreted as setting a
30 precedent. The disciplinary action taken shall be considered final and binding unless
31 a written appeal to arbitration is made within ten (10) days of said disciplinary action
32 in accordance with Step 3 of this subsection as the sole remedy of said disciplinary
33 action.

1 3. **Final Disposition - Arbitration:** If a timely written grievance has not been
2 disposed of as aforesaid to the satisfaction of either party, the City or the Association
3 Executive Board, no later than ten (10) calendar days upon receipt of written
4 response under Step 2, above, may request arbitration as the sole remedy of said
5 dispute before an impartial arbitrator. A copy of such request shall be forwarded to
6 the City Labor Negotiator and the City Attorney.

7
8 (a) **The selection of an impartial arbitrator** shall be as follows:

9
10 The City Labor Negotiator and the representative for the Association shall meet and
11 confer for the purpose of **selecting an impartial arbitrator** acceptable to both
12 parties. In the event the representative for the Association and the City Labor
13 Negotiator are unable to agree upon an impartial arbitrator within ten (10) calendar
14 days after the referral of such matter to arbitration, the representative for the
15 Association or the City Labor Negotiator shall request the Wisconsin Employment
16 Relations Commission to provide a panel of five (5) persons as candidates for the
17 arbitrator. After such panel of names is received, the City Labor Negotiator and the
18 representative for the Association shall alternately eliminate names from such list
19 until one name remains with the appealing party making the initial elimination. Such
20 remaining person shall then become the arbitrator. The arbitrator shall first
21 determine whether the dispute is arbitrable under the express terms of this
22 Agreement. Once it is determined that the dispute is arbitrable, the arbitrator shall
23 proceed to determine the merits of the dispute submitted to arbitration. The
24 arbitrator shall be limited to the terms of this Agreement as written and shall have no
25 power to modify, amend, add to, or subtract from the language of this Agreement in
26 arriving at a determination of any issue presented to him/her for arbitration within the
27 limits expressed herein. No award of any arbitrator may be retroactive for any period
28 prior to the execution of this Agreement.

29
30 **The expenses for the services** of the impartial arbitrator and proceedings shall be
31 borne by the party whom the decision is rendered against; however, each party shall
32 be responsible for compensating its own representatives, witnesses, and such other

1 expenses incurred in the process of selecting an arbitrator and during the arbitration
2 process.

3
4 The arbitrator shall submit his/her award in writing to 1) Attorneys of Record, 2) the
5 Association of Firefighters, and 3) the City Labor Negotiator.

6
7 (b) The arbitrator shall expressly confine himself/herself to the precise issues
8 submitted for arbitration and shall have no authority to determine any other issue
9 not so submitted to him/her or to submit observations or declarations of opinion
10 which are not directly essential in reaching the determination. The arbitrator shall
11 have no authority to grant wage increases or decreases.

12
13 (c) In reviewing any differences with respect to the reasonableness of the application
14 of new departmental rules or regulations primarily related to wages, hours, and
15 conditions of employment under this grievance and arbitration procedure, the
16 arbitrator shall take into account the special statutory responsibilities granted to
17 the Fire Chief under the statutes of the State of Wisconsin and amendments
18 thereto.

19
20 The arbitrator shall not impair the ability of the Fire Chief to operate the
21 department in accordance with the statutory responsibilities under the statutes of
22 the State of Wisconsin and amendments thereto; nor shall he/she impair the
23 authority of the Fire Chief to maintain, establish, and modify rules and regulations
24 for the operation of the Fire Department, provided such rules and regulations are
25 not in violation of the specific provisions of this Agreement. In addition, the
26 arbitrator shall not prohibit the Fire Chief from executing departmental rules and
27 regulations in a fair and equitable manner.

28
29 (d) Chapter 788 shall apply.

30 (e) The award shall be reduced to writing.

1
2
3
4
5
6
7
8
9
10
11
12
13
14
15
16
17
18
19
20
21
22
23
24
25
26
27
28
29
30
31
32

ARTICLE XI

PROHIBITION OF STRIKES

- A. The parties of this Agreement mutually recognize and agree that the services performed by members of the fire force are services essential to the public health, safety, and welfare. Under no circumstances will the Association cause or permit its members to strike, slow down, disrupt, impede, or otherwise impair the normal function of the department; nor shall any member of the bargaining unit take part in any of such prohibited activities.
- B. The Association pledges itself to make every effort to maintain unimpaired the fire service and protection of the community. Should one or more members of the bargaining unit during the term of this Agreement or any extension thereof breach the obligations of Subsection (a), the City shall immediately notify the officers of the Association in writing that a prohibited action is in progress.
- C. The Association shall forthwith, and in any event within twelve (12) hours by the senior responsible officer of the Association, disavow said prohibited action in writing to the Collective Bargaining Committee, order its member or members in writing to return to work or cease the prohibited activity, and provide the City with a copy of its order. Such notification by the Association shall not constitute an admission by it that the prohibitive action is in progress or has taken place. The notification shall be made solely on the presentations of the City. In the event that a wildcat strike occurs, the Association agrees to take all reasonable effective and affirmative action to secure the members' return to work immediately. Failure of the Association to issue such written orders and take such action shall be considered in determining whether or not the Association caused or authorized directly or indirectly the strike.
- D. If the Association disavows the prohibited activity and orders its members in writing to work, the City shall not hold the Association financially responsible and the Association shall interpose no defense to the imposition of such penalties or sanctions as may be assessed against the participants.

- 1 E. An employee who commits any of the acts prohibited in this section after an injunction or
2 restraining order has been issued may be subject to the following penalty. Whoever
3 violates this section after an injunction or restraining order has been issued against such
4 a prohibited activity has been issued shall be fined ten dollars (\$10.00). After the
5 injunction has been issued, any employee who is absent from work because of
6 purported illness shall be presumed to be on strike unless the illness is verified by a
7 written report from a physician to the employer. Each day of continued violation
8 constitutes a separate offense. The court shall order that any fine imposed under this
9 subsection be paid by means of a salary deduction at a rate to be determined by the
10 court.
11
- 12 F. There shall be no lockout by the City during the term of this Agreement.
13
- 14 G. These prohibited acts are dependent upon binding arbitration pursuant to 111.70 of the
15 Wisconsin Statutes being in effect as an alternative to the Association or its members
16 and further are dependent upon the existence of the "Wisconsin No-Strike Statute" being
17 in effect.

1
2
3
4
5
6
7
8
9
10
11

ARTICLE XII
RULES AND REGULATIONS

The rules and regulations of the Sheboygan Fire Department that primarily relate to wages, hours, and conditions of employment shall be made a part of this agreement by this reference. Rules and regulations will be revised and amended as the need arises. The Fire Chief agrees to notify the Union president of any new work rules primarily related to working conditions, wages or hours, before they are put into effect. Any dispute with respect to the reasonableness of the application of work rules primarily related to working conditions, wages, or hours, except those that affect safety, firefighting, emergency medical services, or activities related thereto, shall be subject to the grievance procedure.

1
2
3
4
5
6
7
8
9
10
11
12
13
14
15
16
17
18
19
20
21
22
23
24
25
26
27
28
29
30
31
32
33

ARTICLE XIV

BEREAVEMENT LEAVE WITH PAY

A. When death of the spouse, parent, natural child, or legally adopted child of an employee occurs, the employee upon request will be excused for three (3) normally scheduled tours of duty following the date of death providing he/she attends the funeral. The term "parent" shall mean natural parent and/or a step-parent who has legally adopted the employee.

When death of the employee's mother-in-law, father-in-law, brother, sister, or stepchild occurs, the employee upon request, will be excused for two (2) twenty-four (24) hour tour of duty.

When death of the employee's grandparent, grandchild, or stepparent occurs, the employee, upon request, will be excused for one (1) twenty-four (24) hour tour of duty.

Upon request by the employee and approval of the Fire Chief of the department, the days in this section may be altered due to extenuating circumstances regarding the services, scheduling, or travel distance.

B. An employee excused from work under this section shall, after making application, receive the amount of wages, exclusive of shift or any other premiums, that he/she would have earned by working during straight time hours on such scheduled days of work for which he/she was excused. Time thus paid will not be counted as hours worked for purposes of overtime.

C. In the event of a simultaneous tragedy affecting more than one (1) of the covered relatives enumerated above, not more than three (3) normally scheduled tours of duty shall be excused with pay; and all such paid days shall be subject to the terms and conditions heretofore stated in this section.

D. As noted in Article VI (Definitions), forty- (40) hour per week employees will receive two (2) workdays per twenty-four (24) hour tour of duty.

1
2
3
4
5
6
7
8
9
10
11
12
13
14
15
16
17
18
19
20
21
22
23
24
25
26
27
28
29
30
31
32
33

ARTICLE XV

BASE PAY AND LONGEVITY PLAN

A. The classification by titles used in this section shall be those in common use in Fire Departments and the words title and position shall be synonymous.

B. There shall be three pay scales (**F, G, and H**) for employees in the Fire Department.

Base Schedule F includes all employees hired prior to 1/1/2001. Exceptions: Trevor Saeger, despite being hired after 1/1/2001, shall be a Base Schedule F employee. Brent Adamson, despite being hired prior to 1/1/2001, shall be a schedule H employee.

In the event a schedule F employee obtains a paramedic license, he/she will be placed on schedule H.

Base Schedule G is a temporary transition Base Pay Schedule intended to grandfather current employees in the 2011 Schedule G intermediate steps (1-5). This includes employees hired between 1/1/2005 and 1/1/2012. Once an employee completes his/her 7th year of employment, he/she moves to Schedule H. Once all current employees complete their 7th year of employment, this Base Pay Schedule G evaporates.

Base Schedule H is for all employees hired after 1/1/2012. All employees hired after 1/1/2001 with at least 7 years of employment. All Schedule G employees when he/she complete their 7th year of employment (see above). Exceptions: Trevor Saeger, despite being hired after 1/1/2001, shall be a Base Schedule F employee. Brent Adamson, despite being hired prior to 1/1/2001, shall be a Schedule H employee.

C. **Schedule F and G**

Entrance Rate

Step 2 - After twelve (12) months

Step 3 - After twenty-four (24) months

1 **Step 4** - After thirty-six (36) months requires FEO certification, see
2 **Maximum Rate Step 5** - After forty-eight (48) months – Base Rate

3
4 In addition to the base rates for each position, five (5) longevity steps (Steps 6, 7, 8, 9 and
5 10) are provided in the compensation plan.

6
7 **Step 6** - After five (5) years' continuous service and one (1) year at maximum
8 rate - an additional one and one-half (1-1/2) percent biweekly to Step 5.

9
10 **Step 7** - After ten (10) years' continuous service and one (1) year at maximum
11 rate - an additional one and one-half (1-1/2) percent biweekly for a total of three (3)
12 percent biweekly added to Step 5.

13
14 **Step 8** - After fifteen (15) years' continuous service and one (1) year at maximum
15 rate - an additional one and one-half (1-1/2) percent biweekly for a total of four and
16 one-half (4-1/2) percent biweekly added to Step 5.

17
18 **Step 9** - After twenty (20) years' continuous service and one (1) year at maximum
19 rate - an additional one and one-half (1-1/2) percent biweekly for a total of six (6.0)
20 percent biweekly added to Step 5.

21
22 **Step 10** - After twenty five (25) years' continuous service and one (1) year at
23 maximum rate - an additional one and one-half (1-1/2) percent biweekly for a total of
24 seven and one-half (7.5) percent biweekly added to Step 5.

25
26 **D. Schedule H Entrance Rate**

27 **Step 2** - After twelve (12) months

28 **Step 3** - After twenty-four (24) months

29 **Step 4** - After thirty-six (36) months requires FEO certification, see

30 **Step 5** - After forty-eight (48) months

31 **Step 6** - After sixty (60) months

32 **Maximum Rate Step 7** - After seventy-two (72) months - Base Rate

City of Sheboygan/Local 483 Contract

January 1, 2018 to December 31, 2020

1
2
3 In addition to the base rates for each position, four (5) longevity steps (Steps 8, 9, 10, 11
4 and 12) are provided in the compensation plan.

5
6 **Step 8 - After seven (7) years'** continuous service and one (1) year at maximum
7 rate - an additional one and one-half (1-1/2) percent biweekly to Step 7.

8
9 **Step 9 - After ten (10) years'** continuous service and one (1) year at maximum rate - an
10 additional one and one-half (1-1/2) percent biweekly for a total of three (3) percent
11 biweekly added to Step 7.

12
13 **Step 10 - After fifteen (15) years'** continuous service and one (1) year at maximum
14 rate - an additional one and one-half (1-1/2) percent biweekly for a total of four and
15 one-half (4-1/2) percent biweekly added to Step 7.

16
17 **Step 11 - After twenty (20) years'** continuous service and one (1) year at maximum
18 rate - an additional one and one-half (1-1/2) percent biweekly for a total of six (6.0)
19 percent biweekly added to Step 7.

20
21 **Step 12 - After twenty five (25) years'** continuous service and one (1) year at
22 maximum rate - an additional one and one-half (1-1/2) percent biweekly for a total of
23 seven and one-half (7.5) percent biweekly added to Step 7.

24
25 The above salaries shall be rounded off so that the biweekly pay is divisible by eighty (80)
26 hours in even cents per hour. Step 10 to be effective January 1, 2012.

27
28 E. All advances are on the employee's anniversary date and the new rate shall be paid on
29 the first full pay period thereafter. Advancement to each step (intermediate and
30 longevity) shall be made in accordance with the steps listed prior unless the employee's
31 performance is rated unsatisfactory on the annual final personnel evaluation report.
32 Each employee's Annual Final Personnel Evaluation (FD61) shall be completed one (1)
33 month in advance of his/her anniversary date, enabling it to be used as a source for the

1 completion of any applicable "Payroll Change Notice". The evaluation on the "Payroll
2 Change Notice" is intended to be a synopsis of the more detailed Fire Department
3 personnel evaluation completed by each employee's officer. If rated unsatisfactory, such
4 employee shall be reevaluated after six (6) months from the initial unsatisfactory
5 evaluation. If an employee who was rated unsatisfactory is not rated unsatisfactory at
6 the end of the six (6) month reevaluation, the employee shall then receive the step or
7 longevity increase that was withheld based upon his/her seniority. A Payroll Change
8 Notice shall be submitted in conjunction with the next full pay period after the employee
9 receives the rating. The step increase will not be retroactive, but additional steps will
10 continue to be based on the employee's date of hire.

11
12 F. The Fire Chief must recommend in writing the advancement in salary of each employee
13 in his/her department who has met the requirements for compensation advancement.

14
15 G. All subsequent contracts will use the base pay and longevity rates therein contained.
16 Changes in the compensation schedules shall be made in such manner as to maintain
17 proper percentage relationships between the positions.

ARTICLE XVI

SALARY AND WAGE SCHEDULE

A.

Firefighting Force

<u>Grade</u>	<u>Title</u>
01	Firefighter
01A	Acting Fire Equipment Operator
02	Fire Equipment Operator
03	Lead Firefighter
04	Fire Lieutenant
05	Fire Captain

Specialists/Fire Prevention Bureau

08	Chief Fire Inspector
----	----------------------

B. For all employees hired after January 1, 1995, a new Class Grade 01 shall be created.

New rates shall be established at:

Step 1 - 67% of Step 5

Step 2 - 79% of Step 5

Step 3 - 86% of Step 5

Step 4 - 93% of Step 5

C. All class grades shall receive a 2018 wage increase of two (2.0) percent on Steps 1 through 5 (or step 1-7 on Schedule H) effective January 1, 2018, rounded off so that the biweekly pay is divisible by eighty (80) hours in even cents per hour. All class grades shall receive a 2019 wage increase of two and one quarter (2.25) percent on Steps 1 through 5 (or step 1-7 on Schedule H) effective January 1, 2019, rounded off so that the biweekly pay is divisible by eighty (80) hours in even cents per hour. All class grades shall receive a 2020 wage increase of two (2.0) percent on Steps 1 through 5 (or step 1-7 on Schedule H) effective January 1, 2019, rounded off so that the biweekly pay is divisible by eighty (80) hours in even cents per hour.

City of Sheboygan/Local 483 Contract

January 1, 2018 to December 31, 2020

- 1 D. Effective at City discretion, no earlier than thirty (30) days after mutual signatures of the
2 1998-2000 Agreement, **direct deposit** shall be mandatory for all employees.
3
- 4 E. The City and the Union agreed to standardize the payroll system to make pay periods
5 the same. All employees will have a two (2) week holdback of pay.

1
2
3
4
5
6
7
8
9
10
11
12
13
14
15
16
17
18
19
20
21
22
23
24
25
26
27
28
29
30
31
32
33

ARTICLE XVIII
UNIFORM ALLOWANCE

- A. Effective January 1, 2003, Each new appointee to the Fire Department who is required to wear a uniform shall be paid one hundred dollars (\$100.00) for an initial uniform allowance. Said one hundred dollars (\$100.00) shall be paid on the pay day following the completion of the required probationary period.
- B. In addition, such employees shall be compensated at the rate of one-twelfth (1/12) of the prevailing annual uniform allowance per month for the period between the beginning of the probationary period and the end of the calendar year in which said probationary period started, which additional amount shall be paid on the first pay day in January or on completion of probation when two (2) calendar years are involved.
- C. Effective January 1, 2016, payable during the month of January each calendar year, a four hundred twenty-five dollar (\$425.00) uniform allowance shall be paid to all other members of the Fire Department who are required to wear uniforms.
- D. Upon termination, any employee that has successfully completed probation receiving benefits under this provision shall receive the prorated allowance for each full month worked in the current year.
- E. All personnel are required to have a Class A uniform by July 1, 2016. Probationary employees shall be required to purchase a current uniform within 6 months of completing probation. Employees assume responsibility for purchasing NFPA compliant boots and helmet when current department issued equipment becomes obsolete. Helmet shall be Conway/Lion American Heritage or Classic. If manufacturer discontinues current style, the City and Union shall agree to a replacement style. Probationary employees will be provided boots and helmet during probation and up to 12 months after successful completion of probation.
- F. **The City shall supply protective clothing** to members of the Fire Department, including, raincoats, gloves, and bunker pants. The standards of equipment furnished

1 shall be established by the Fire Chief or his/her designee, and worn-out equipment must
2 be turned in before replacement or when employment with the Fire Department is
3 discontinued. Bedding shall be the responsibility of the employee.
4

5 **ARTICLE XIX**
6 **SPECIAL SALARY PROVISIONS**
7

8 **A. All supervisors shall be paid at a higher rate than their subordinates.** In the event
9 that because of difference in length of service a supervisor is paid a rate of pay equal to
10 or lower than one (1) of his/her subordinates, the supervisor shall be advanced to a step
11 in his/her salary range which will provide him/her a rate of pay one (1) increment higher
12 than any subordinate, regardless of the supervisor's length of service.
13

14 **B. In the event a member of the Association is promoted to a class with a higher pay**
15 **range,** the entrance rate shall be at the employee's same step at the higher
16 classification. Applicable longevity increases within the twelve (12) months after
17 promotion will be effective on the first full pay period following the years of service
18 requirements. The first twelve (12) months shall be considered the period of probation.
19

20 In the event a promoted employee does not pass probation, the employee will be re-
21 assigned, without retesting, to his/her previous rank prior to promotion when the next
22 vacancy occurs, according to the following process:

- 23 1. The employee's current position will be filled from the promotional list and the
24 employee not passing probation will be re-assigned to a vacant position within
25 the employee's previous rank.
26
- 27 2. If there is no immediate opening within the employee's previous rank, the
28 employee will be temporarily assigned to an available lower rank until the next
29 vacancy occurs within the employee's previous rank.
 - 30 a. The lower rank assignment will be within the highest rank available for
31 which the employee is qualified.

City of Sheboygan/Local 483 Contract

January 1, 2018 to December 31, 2020

1 b. The employee will receive pay at the rank he/she previously held while
2 waiting for a vacancy to occur.

3
4 c. There will be no expiration date for the employee to return to his/her
5 previous rank. When that vacancy occurs, the employee's circumstance will
6 supersede filling the vacancy from the promotional list.

7
8 d. The employee's seniority in rank shall be continued as if the employee
9 never left his/her previous position.

10
11 The same process will be used in the event an employee is demoted.

12
13 C. An employee whose **entrance rate is at the minimum** of the base range shall be
14 advanced to the next higher rate at the beginning of the pay period following the
15 completion of the first twelve (12) months of service, providing his/her service has been
16 satisfactory. The probationary period may be extended by the Fire Chief. The
17 employee's adjusted anniversary date shall be the date of acceptance. Subsequently,
18 the employee shall be advanced annually to the higher rates within the pay range on the
19 employee's adjusted anniversary date; and the new rate shall be paid on the first full
20 pay period thereafter.

21
22 D. For employees hired after January 1, 2002: An employee must become certified by the
23 Sheboygan Fire Department as a Fire Equipment Operator (FEO) prior to receiving his
24 Step 4 (36 month) pay increase. In the event that an employee certifies as an FEO
25 some time after the 36 month step, his/her pay will be adjusted to the appropriate step
26 (based on date of hire) in the first full pay period following the FEO certification. Future
27 step increases shall be based on date of hire, not date of FEO certification.

28
29 E. Effective January 1, 2012, compensation for working out of grade becomes part of an
30 employee base salary. The most senior qualified employee shall be expected to act in
31 the higher grade, however if there is another qualified employee in the same station the
32 most senior may waive the opportunity to work in the higher grade. When applicable

1 the least senior qualified employee will be assigned roving duties, however the most
2 senior qualified employee may elect to accept roving duties.

3 1. A Captain or a Lieutenant acting as a Battalion Chief shall receive an
4 additional (6 ½%) above Captains rate in the same step while so assigned.
5 Acting out of grade for less than eight (8) hours during a twenty-four hour period
6 shall not be compensated. The intent is that a Captain and a Lieutenant shall
7 each earn the same amount for acting as a Battalion Chief. A Captain or
8 Lieutenant acting as a Battalion Chief shall receive an additional six and one-half
9 (6 ½%) percent above the same step in Class Grade 05 while so assigned.
10 Acting out of grade for less than eight (8) hours during a twenty-four (24) hour
11 shift will not be recorded and will not be compensated.

12
13 2. In the event of an absence (longer than 30 days) in a paid position (FEO, LT,
14 or Captain), the assigned replacement employee(s) will receive out of grade pay
15 beginning the 31st day of the absence. In the event that absence was created
16 due to a promotional delay, the assigned replacement employee(s) will receive
17 out of grade pay retroactive to the first day of absence. In the event that absence
18 was created due to normal usage of vacation/compensatory time, no out of grade
19 will be received. The employee(s) shall receive the pay rate of the higher
20 classification in their current pay step. Due to vacations, roving, etc the
21 replacement employee may be more than one employee.

22
23 Payment for working in a higher classification will be paid annually on the first payday in
24 February, unless it is practicable to pay it out on the payday after it is earned.

25
26 Effective January 1, 2012, Acting Pay and Paramedic 2% "rig" pay will be rolled up into a one-
27 time \$910.00 addition to each firefighters pay.

28
29 **F. Instructor Premium Pay.**

30
31 1. An **off-duty employee requested to instruct** department-required training, as
32 designated by the Fire Chief as extra duty, will be paid at the time and one-half (1-1/2)

1 rate computed by dividing the regular biweekly pay divided by one hundred twelve (112)
2 x hours worked x one and one-half (1-1/2).

- 3
- 4 2. An **on-duty employee requested to instruct** department-required training as
5 designated by the Fire Chief as extra duty, will receive instructor premium pay of an
6 additional fifty (50) percent of the employee's regular hourly rate (biweekly rate without
7 holiday pay divided by one hundred twelve (112) times five tenths (.5) times the hours of
8 instruction.).

9

10 **G. Sheboygan Fire Department Instructors.**

- 11
- 12 1. The Fire Department shall pay all costs (registration, lodging, books, mileage, etc.) to
13 attend any course required for a Fire Department instructor to maintain his/her status to
14 teach that course. The Fire Department may, under the discretion of the Fire Chief, pay
15 costs for a Fire Department instructor, to attend a course that can enhance that
16 employee's knowledge of their field of expertise.

- 17
- 18 2. When practical, on-duty time will be provided to a Fire Department instructor to
19 adequately prepare for his/her presentations.

- 20
- 21 3. When approved, those employees volunteering or assigned as instructors shall be
22 eligible for compensation while preparing for training programs and will be paid at the
23 time and one-half (1-1/2) rate computed by dividing the regular biweekly pay divided by
24 one hundred twelve (112) x hours worked x one and one-half (1-1/2). Approval from the
25 Fire Chief or his/her designee is on a case-by-case basis.

26

27 **H. Premium pay for work outside normal station work routine hours.**

- 28
- 29 1. Public relations/education. On duty employees required to represent the fire
30 department for the purpose of public relations or public education outside the
31 normal station work routine hours (8am-5pm weekdays, 8-11 Sat./Sun./holidays)
32 will receive premium pay of an additional fifty (50%) percent of the employee's

1 regular hourly rate (biweekly rate without holiday pay divided by one hundred
2 twelve (112) times five (.5) tenths) for time assigned.

- 3
- 4 2. Training. The City may require each employee to participate in two (2) training
5 sessions per calendar year, to a maximum of four (4) hours outside the normal
6 station work routine hours, at no additional expense to the City. Additionally,
7 training sessions participated in with outside agencies other than solely the
8 Sheboygan Fire Department must not exceed an additional six (6) sessions per
9 calendar year, to a maximum of eighteen (18) additional hours outside the
10 normal station work routine hours. (Sundays, and holidays are excluded.)
11 Additional training may take place as agreed upon by The Chief or his/her
12 designee and the Union president or their designee.

13

14 **I. Paramedic Preceptor Compensation**

15 .

16 Each semester the Fire Chief, or his/her designee, will determine whether the Sheboygan
17 Fire Department will participate in a paramedic preceptor program. The participation level
18 shall not exceed one (1) paramedic student per ambulance

19

20 The division of assignment and scheduling of assignment will be determined by the Fire
21 Chief or his/her designee. Upon selection of station of the preceptor assignment, the most
22 senior paramedic assigned to the ambulance will be given the option of precepting. If
23 he/she declines, the other paramedic (if eligible) shall be assigned the duty. The preceptor
24 shall be the "lead" paramedic on the assigned day. Probationary employees will not be
25 assigned preceptor function.

26

27 For each 12 hour segment, the preceptor will accrue one (1) hour of compensatory time.
28 Use of compensatory time earned is subject to the Department's Vacation/Comptime Leave
29 Policy.

30

31 In the event a preceptor would be subject to loss of Emergency Medical Technician (EMT)
32 license resulting from his/her role/duties as a preceptor, he/she would maintain employment
33 and would not be bound by the condition of employment requirement of maintaining an EMT

1 license. Said employee would be expected to make full efforts to regain his/her EMT
2 license.

3 **ARTICLE XX**
4 **SEVERANCE PAY**

5
6 A. Effective January 1, 1988, an employee upon retirement, layoff without cause on the
7 part of the employee, or death, will receive the following severance pay, less any amount
8 paid out as a result of any previous terminations.

9
10 Effective January 1, 1998, the applicable pay rate for severance pay, for an employee
11 retiring after December 18th in any given year, shall be set at the rate in effect on the
12 first day of the next month. (E.g., if an employee retires on Dec. 26, 1998, he/she shall
13 receive his/her severance payout at the Jan. 1, 1999 rate.) If there is no successor
14 agreement in place at the time of retirement, an additional retroactive adjustment
15 payment will be paid when the successor agreement terms become known.

16
17 Provided an employee gives a minimum of 30 day notice of retirement, monies earned
18 from FLSA compensatory time, from acting out of grade, and holdback will be paid in the
19 calendar year of the retirement notice.

20
21 1. **Vacation.** All unused vacation and earned vacation pay for all months of service
22 from January 1 to the date of retirement.

23
24 a. For employees assigned to the 24-hour shift duty, the formula for a tour of duty
25 shall be regular biweekly pay including holiday divided by 112 multiplied by 24.

26
27 For example, a 26-year employee retires on August 29, without using any
28 vacation during his retirement year. He will have earned 14 tours of duty of
29 unused vacation and 7/12 (number of full months worked) times 14 tours of duty
30 of earned vacation (=8.17 of earned vacation). His total vacation severance pay
31 would be 22.17 (14 plus 8.17) times his tour of duty rate as defined above.

1 b. For employees assigned to the 8-hour workday schedule, the formula for a day
2 shall be regular biweekly pay divided by 80 multiplied by 8.

3
4 For example, a 26-year employee retires on August 29 without using any
5 vacation during his retirement year. He will have earned 25 days of unused
6 vacation and $7/12$ (number of full months worked) times 25 of earned vacation
7 (=14.58). His total vacation severance pay would be 39.58 (25 plus 14.58) times
8 his daily rate as defined above.

9
10 2. **Compensatory Time.** All accrued compensatory time, except Fair Labor Standards
11 Act overtime, shall be paid at one and one-half ($1-1/2$) times the employee's regular
12 biweekly pay at the time of termination. All Fair Labor Standards Act compensatory
13 time shall be paid out at the biweekly regular rate as defined by law divided by one
14 hundred twelve (112) x five-tenths ($.5$) x accrued hours.

15
16 3. A full-time employee in the bargaining unit with five (5) years or more continuous
17 service is entitled to payment of one-half ($1/2$) of all **accumulated sick leave** up to a
18 maximum of seventy-two (72) days' pay upon retirement, lay off without cause on the
19 part of the employee, or death, less any amount paid out as a result of any previous
20 termination. The employee, upon request, shall be allowed to deposit the after-tax
21 value of one-half ($1/2$) of all accumulated sick leave, up to a maximum of seventy-two
22 (72) days, for the purpose of payment of health insurance premiums, not to exceed
23 the cost of insurance premiums for one year and including any increase in insurance
24 premiums, as applicable. A day's pay does not include holiday pay if previously
25 paid, and the rate of pay shall be the rate in effect at the time of retirement.

26
27 4. In addition, any employee who has successfully completed probation shall receive
28 his/her **uniform allowance** prorated one-twelfth ($1/12$) for each full month of
29 employment in the current year.

30
31 B. **Upon voluntary termination**, an employee will receive the following severance pay less
32 any amount paid out as a result of any previous terminations.

1
2
3
4
5
6
7
8
9
10
11
12
13
14
15
16
17

1. **Vacation:**

(a) All unused vacation pay shall be paid at the employee's biweekly rate with holiday pay for 56 hour-per-week employees.

(b) All unused vacation pay shall be paid at the employee's biweekly rate for 40 hour per-week-employees.

2. **Compensatory time.** All accrued compensatory time except Fair Labor Standards Act overtime shall be paid at one and one-half (1-1/2) times the employee's regular biweekly rate of pay at the time of termination. All Fair Labor Standards Act compensatory time shall be paid out at the biweekly regular rate as defined by law divided by one hundred twelve (112) x five-tenths (.5) x accrued hours.

3. In addition, any employee who has successfully completed probation shall receive his/her **uniform allowance** prorated one-twelfth (1/12) for each full month of employment in the current year.

1 **ARTICLE XXII**

2 **VACATION - FLSA AND REGULAR COMPENSATORY TIME - EMS DAY**

3
4 This vacation – FLSA/regular compensatory time - EMS day article describes the granting of
5 leaves of absence for the use of vacation, FLSA or regular compensatory time, an EMS day, or
6 the benefits of Convention Leave or School for Workers. Contractual leaves of absence for the
7 use of vacation, FLSA or regular compensatory time off, an EMS day, Convention Leave, or
8 School for Workers are to effectively maintain staffing levels and work schedules of department
9 personnel.

10
11 **Leave Period** - One of seven time frames throughout a calendar year that contains five leave
12 cycles.

13 **Leave Cycle** – A sequential combination of three scheduled tours of duty assigned as vacation
14 days.

15 **EMS Day** - Regarded the same as a vacation day for granting as a leave of
16 absence.

17
18 **ADMINISTRATION**

19
20 A. Employees may use cycles for vacation, an EMS day, Convention Leave, School for
21 Workers, FLSA and regular compensatory time requests, or as required by law. The
22 computer entry of a leave of absence request is the responsibility of the employee.

23
24 B. A maximum of four union personnel will be approved for leaves of absence in
25 accordance with this article at any given time. Personnel off on leave for department
26 funded and/or required business would be considered as one of the four union
27 personnel. (This is a factor in granting untimely off-duty and same day leave of absence
28 requests only.)

29
30 C. Of the allotted four (4) persons, no more than two (2) paramedics will be approved for
31 leaves of absence on the same date(s). This rule will be in effect unless ten (10) or
32 more paramedics are assigned to the shift.

City of Sheboygan/Local 483 Contract

January 1, 2018 to December 31, 2020

- 1 D. If an employee has not requested the use (all or part) of a selected cycle within fifty (50)
2 days prior to the start of the cycle, the cycle is considered vacated and available to other
3 employees. Requests made forty-nine (49) through forty-five (45) days prior to the start
4 of a vacated cycle will be considered as received at the same time and will be awarded
5 in preference of the employee requesting a full cycle and then by seniority. Days in
6 vacated cycles that were not requested as a full cycle will be approved as timely forty-
7 five (45) days in advance of each individual day. A separate entry must be made for
8 each date requested. Requests for full tours of duty take preference over partial tour
9 requests.
- 10
- 11 E. Timely requests shall be submitted at least forty-five (45) days prior to the requested
12 date. Timely requests are considered final; no request for change will be honored.
- 13
- 14 F. Leave of absence requests for days outside of scheduled cycles or untimely unused
15 days within scheduled cycles will be approved on a first-come, first-served basis, and the
16 earliest dated request will be given preference. In the event that two or more requests
17 for the same date are entered on the computer on the same date, preference will be
18 given to the employee requesting a full tour, and then by seniority.
- 19
- 20 G. Untimely requests for more than one date must have separate entries for each
21 requested date.
- 22
- 23 H. Untimely requests may be approved once the fourteen (14) days prior limit elapses
24 providing the minimum staffing level for the date requested will be maintained.
25 Employees making untimely requests must verify approval within six (6) days of the date
26 requested with the Fire Chief or his/her designee to be granted final approval.
- 27
- 28 I. The Battalion Chief may approve an employee's request for a leave of absence on the
29 same day requested, subject to the limitations set forth in **Item O** (Exceptions). Same
30 day requests will be approved in preference of the greatest number of hours requested
31 and then by seniority. The Battalion Chief will receive requests between 6:45 a.m. and
32 7:00 a.m. The employee requesting leave must call the Battalion Chief back after 7:00
33 a.m. to confirm the leave.

1
2 J. All requests for vacation or an EMS day, timely or untimely, shall be for full tours of duty.

3
4 K. All FLSA or regular compensatory time requests between the hours of 8:00 a.m. and
5 8:00 p.m. shall be for a minimum of four (4) hours. Requests for time extending past
6 8:00 p.m. shall be for the remainder of the shift.

7
8 L. Leave periods will be selected by seniority. No more than two (2) paramedics per shift
9 may choose the same leave period. The two (2) paramedic rule will be in effect unless
10 ten (10) or more paramedics are assigned to the shift. In the event that there are less
11 than eight (8) paramedics on a given shift, two (2) paramedics may not select the same
12 period (the previous sentence will be removed from the contract when the department
13 has twenty-four (24) paramedics). Trading or relinquishing selected dates is the
14 responsibility of the employee. To ensure that the responsibility is properly placed, a
15 cycle trade must be signed by both employees involved.

16
17 In the event that an employee(s) is transferred, he/she will retain his/her chosen leave
18 cycle provided he/she remains on the same shift. In the event that an employee(s) is
19 transferred to a different shift, he/she will be assigned the vacant leave period. Although
20 these instances may result in a potential violation of the rule outlined in paragraph C,
21 timely requests will still be granted for assigned cycles. In the event that more than one
22 (1) vacation period is available due to multiple transfers, the vacation periods will be
23 selected by seniority. The selection process will still be subject to the selection rule
24 regarding two (2) paramedics at one time. For assigned (not chosen) transfers,
25 reasonable efforts to accommodate immediate vacation needs will be made.

26
27 M. In the event that an employee trades a cycle, or any portion of a cycle, and the
28 employee is subsequently transferred to a different shift, the cycle and periods become
29 the property of the employee newly appointed to the shift. Any trade or trades of the
30 transferred employee's former assigned cycles must be renegotiated with the newly
31 appointed employee. If there are fewer than fifty (50) days between the newly appointed
32 employee's date of assignment and the first day of the cycle or date within the cycle

1 previously requested or traded, the requested cycle or trade is to be honored by the new
2 appointee.

3
4 N. At no time will this article abrogate or supersede the powers of the Fire Chief as
5 contained in Article VII (B) of the existing contract.

6
7 O. Exceptions: Untimely vacation-FLSA compensatory time may not be granted under the
8 following conditions:

9 a. The absence causes the department to call in a replacement because of the inability
10 of the department to obtain a replacement from the remaining on duty personnel.

11 b. A department-sponsored school or training causes staffing to drop to the minimum
12 level.

13
14 P. Employees may initially request two (2) open cycles. Requests will be granted by
15 department seniority; however, requests for complete cycles take precedent over requests
16 for partial cycles. Remaining cycles may be re-applied for and granted by seniority. The
17 employee must use open cycles granted to an employee.

18
19 **Summary of Leave of Absence Timetable:**

20
21 **Fifty (50) days or more in advance of the first date of the cycle:** requests in selected or
22 traded cycles *are timely*.

23 **Under fifty (50) days in advance of the first date of the cycle:** dates not requested *are*
24 *considered to be vacated*.

25 **Forty-five (45) through forty-nine (49) days in advance of the first day of any vacated**
26 **cycle:** requests for entire vacated cycles are timely. Requests for entire cycles submitted
27 during this time period are granted by seniority.

28 **Forty-five (45) through forty-nine (49) days in advance of any vacated tour of duty:**
29 requests for any individual vacated tour of duty are timely. When an entire vacated cycle has
30 not been requested, then each vacated tour of duty will be granted by seniority.

31 **Forty-four (44) through fourteen (14) days in advance of each date:** requests *are untimely*.

32 **Under fourteen (14) days in advance of each date:** only same day requests can be granted.

1
2
3
4
5
6
7
8
9
10
11
12
13
14
15
16
17
18
19
20
21
22
23
24
25
26
27
28
29
30
31

ARTICLE XXIII
UNION ACTIVITIES

- A. The City agrees to allow a Union Steward and/or the members of the Grievance Committee sufficient time for the proper processing of a grievance as outlined in this Agreement. The aggrieved party shall also be given sufficient time off for the proper processing of his/her grievance.
- B. Business agents or representatives of the Union having business with the officers or individual members of the Union may confer with such officers or members during the course of the working day for a reasonable length of time, providing that permission is first obtained from the commanding officer or superior officer of that Union officer or member.
- C. The City agrees not to deduct such reasonable time from the pay of such officers or members and agrees also that time spent in the conduct of grievance and in bargaining shall not be deducted from pay of delegated employee representatives of the Union.
- D. Members of the bargaining committee who are on duty on the days the City meets with this committee shall also be given time off to attend such meetings up to a combined maximum of 100 man hours for on-duty time spent annually unless extended by mutual agreement.
- E. The Union's grievance committee shall be determined by the Association. The Union's bargaining Committee will be determined by the Association. Either party may select an attorney for purposes of conducting negotiations under the provisions of 111.70 of the Wisconsin Statutes.
- F. No payment will be made for time spent outside the normal workday or workweek for Union business unless required by law.

1 G. No union member or officer shall conduct any union business on City time except as
2 specified in this Agreement. No union meeting shall be held on City time or city property
3 without authorization of the Fire Chief.
4

5 No payment will be made for time spent outside the normal workday or workweek for Union
6 business unless required by law.

7 No union member or officer shall conduct any union business on City time except as specified in
8 this Agreement. No union meeting shall be held on City time or City property without
9 authorization of the Fire Chief.

10 **ARTICLE XXIV**
11 **MILITARY SERVICE**
12

13 A. All state or federal laws pertaining to service in the armed forces by an employee on
14 temporary leave of absence for such military service is hereby made a part of this
15 Agreement by reference.
16

17 B. All leaves of absence for military service will be without pay. No sick leave accumulation
18 or City payment of health insurance premium will be made for absences of one full
19 calendar month or more. Vacation and an EMS day will be accrued and holiday pay will
20 be received during military leave. Seniority in department and in rank will accrue during
21 military leave. The employee will be reassigned to his/her position prior to military leave
22 or, if practicable, promoted or transferred to positions posted during his/her absence.

1
2
3
4
5
6
7
8
9
10
11
12
13
14
15
16
17
18
19
20
21
22
23
24
25
26
27
28
29
30
31
32
33

ARTICLE XXV

SICK LEAVE

A. Personnel on extended sick leave must report, on a weekly basis, to the Fire Chief or his/her designee either in person or by telephone stating his/her condition, work limitations, and anticipated date of return to duty.

1. Each member covered by the Agreement shall be entitled to sick leave credit of one (1) workday with pay for each completed month of service with pay. Unused sick leave may be accumulated up to a maximum of one hundred forty-four (144) workdays.

2. Unused sick leave accumulated in excess of one hundred forty-four (144) days prior to 1985 shall be pooled in the Fire Department and may be restored for use by individual members of the Department in the event of an extended illness. All such requests to participate in the sick leave pool must be made in writing by the employee to the Fire Chief setting forth and including the following information:

a. Submission of satisfactory medical evidence from a physician on a form prescribed by the City listing the qualified serious health condition of the employee certifying that the employee has been incapacitated for said period of absence, the estimated period of time the employee will continue to be incapacitated, and the nature and prognosis of the illness or injury.

b. An employee who is using sick days from the sick leave pool shall furnish an updated Physician's Report from his/her physician on the form prescribed by the City more or less than thirty (30) days for recertification unless this requirement is waived by the Fire Chief or his/her designee.

3. The administration of the sick leave pool shall be under the jurisdiction of the Director of Human Resources following consultation with the Fire Chief and Local 483 President, in compliance with the applicable state and federal laws included ADA and FML, etc. One representative from each station will be given the

1 opportunity to be heard regarding the application of Section (3). Each employee
2 must accumulate the basic one hundred forty-four (144) days' sick leave and all
3 additional days shall then be credited to his/her retirement insurance credit
4 account. An employee is not eligible to participate in the sick leave pool or bank
5 if he/she is eligible for other City-paid benefit programs, including, but not limited
6 to the following list:

7
8 City-paid retirement disability programs

9 Social Security disability benefits

10 City-paid annuity programs

11
12 4. Employees absent from work on legal holidays, during sick leave, vacation, or
13 disability arising from injuries sustained in the course of their employment, or for
14 authorized leaves of absence with pay shall continue to accumulate sick leave at
15 the regularly prescribed rate during such absence as though they were on duty,
16 subject to the maximum limitation herein provided.

17
18 5. An employee eligible for sick leave with pay may use such sick leave upon
19 approval of the Fire Chief for absence due to non-occupational illness, injury,
20 exposure to contagious disease, or up to two (2) tours of duty in an emergency
21 due to serious illness in the employee's immediate family. The terms
22 "emergency due to serious illness" as referred to above is such illness, which in
23 the reasonable opinion of a physician, requires immediate and indispensable
24 care or hospitalization. The term "**immediate family**" as referred to in this
25 section is hereby defined as follows:

26 a. Spouse of the employee.

27 b. Unemancipated children of the employee under the age of 18.

28 c. Disabled dependents of the employee who are wholly dependent upon
29 the employee for their support and maintenance and who reside in the
30 employee's household.

31
32 If while on duty, an employee's wife has a normal pregnancy delivery devoid of
33 serious complications, said employee may utilize sick leave or the remaining

1 portion of that four of duty, regardless of departmental staffing needs. In
2 addition, said employee may use up to either two (2) days of vacation, accrued
3 compensatory time, or unpaid leave of absence to attend to personal business
4 during the period of his/her wife's convalescence regardless of departmental
5 staffing needs. Employees will not be ineligible for benefits as contained in this
6 Agreement as result of said time off to attend to personal business.

- 7
- 8 6. The Fire Chief or his/her designee may require a medical certificate to justify the
9 granting of sick leave.
- 10
- 11 7. An employee on sick leave shall inform his/her immediate supervisor of the fact
12 and the reason therefore prior to the day of absence or as soon as possible but
13 no later than eight (8:00) a.m. of the first day of absence; and failure to do so
14 within a reasonable time may be cause for denial of pay for the period of
15 absence.
- 16
- 17 8. Absences for a fraction or part of a day that are chargeable to sick leave in
18 accordance with these provisions, shall be charged proportionately in an amount
19 not smaller than one-eighth (1/8) day for employees who work a twenty-four (24)
20 hour tour of duty. Absences for a fraction or part of a day that are chargeable to
21 sick leave shall be charged in one (1) hour increments for employees working a
22 regular eight hour shift.
- 23
- 24 9. Employees who work a twenty-four (24) hour tour of duty shall be charged at the
25 rate of two (2) days for each twenty-four (24) hour tour of duty that is missed.
26 The employee shall be charged in proportion to the time missed in amounts not
27 smaller than one-eighth (1/8) day of sick leave. (Schedule of Sick Leave
28 Attached, Exhibit B)
- 29
- 30 10. It is recognized that sick leave is a valuable benefit paid for by the City to be
31 used solely for bona fide sickness, accidents, or emergencies.

1 11. Use of the sick leave pool is available to all active employees and is limited to a
2 maximum of 12 months of utilization (once employee enters the sick leave pool).
3 Employees unable to return to work upon the expired 12 months will transition to
4 inactive employment and will either be laid off, need to apply for retirement
5 benefits (if qualified) or long term disability benefits.

6
7 12. In the event any employee has misused the sick leave provisions contained
8 herein or has requested the use of sick leave when such sick leave is not
9 warranted, he/she shall subject himself/herself to disciplinary action.

1
2
3
4
5
6
7
8
9
10
11
12
13
14
15
16
17
18
19
20
21
22
23
24
25
26
27
28
29
30
31
32
33

ARTICLE XXVI

DUTY-INCURRED DISABILITY

A. Each employee covered by this Agreement who becomes subject to the Workers' Compensation Act due to an injury or industrial disease with the City shall receive his/her regular straight-time wages for the period of time he/she is temporarily totally or temporarily partially disabled because of said injury, effective January 1, 2001, not to exceed six (6) months *per* injury, and providing such employee endorses his/her compensation check from the insurance carrier over to the City Finance Director/Treasurer for deposit in the proper fund. The amounts thus received in excess of payments to which the employee would be entitled under the provisions of the Workers' Compensation regulations shall be attributable to and applied as an offset by the City to any claim which the employee may be entitled to because of a permanent injury sustained.

B. After the expiration of the six (6) months, such person shall receive only the compensation to which he/she would be entitled under the provisions of the Workers' Compensation regulations unless permission is granted under (C) below.

C. After the expiration of the six (6) months, such employee may, with the permission of the governing body, use his/her base sick leave under Article XXIV of this contract.

D. Members of the Fire Department who have not completed their initial one (1) year probationary period as new members of the department shall not receive duty-incurred disability pay from the City for any physical condition, or aggravation of a physical condition, preexisting the date of hire of such persons.

E. In the event an employee is injured, either on or off the job, and has physical restrictions that would allow the employee to perform a task in a light-duty capacity, management has the ability to assign work within the restrictions noted by a physician. Employees may be required to move to a flexible, 40-hour work-week, with no loss in pay and/or benefits with the following stipulations:

a) Absence is anticipated to be greater than 3 cycles.

City of Sheboygan/Local 483 Contract

January 1, 2018 to December 31, 2020

- 1 b) Employee may agree to move to a 40-hour work week immediately; however,
2 the light duty assignment may be issued while an employee continues to
3 work on their normal schedule for up to three (3) cycles.
- 4 c) Employee may rescind previously approved vacation during the absence.
- 5 d) Depending on the case, if a hardship exists, the employee may request to
6 remain on their 24 hour shift, appealed to the Chief and Human Resources
7 Director. Examples include issues relating to childcare, eldercare, etc.)
- 8 e) In the event of a non-work related injury/illness and pregnancy, an employee
9 may be eligible for limited term restricted duty subject to available work, skill
10 level, and documented medical restrictions.

1 6. A retiree shall be defined as any City employee who is eligible for, or is receiving,
2 benefits from programs covered by Chapter 40 of the WI State Statutes.
3

4 C. Employees who attain one hundred forty-four days (1,152 hours) of unused sick
5 leave shall be eligible to participate in the **Good Attendance/Retirement Bonus**
6 **Program** effective January 1, 1988. Under the program and upon retirement the
7 employee will be given a maximum of one (1) retirement insurance credit for each
8 unused sick leave day accumulated after January 1, 1985 in excess of one hundred
9 forty-four (144) days. In each case of an extended non-occupational injury or illness
10 in excess of fifteen (15) consecutive tours of duty during the ten (10) calendar years
11 immediately preceding an employee's retirement date an additional one-half (½)
12 credit will be given for each consecutive sick day used in excess of fifteen (15)
13 consecutive tours of duty during said injury/illness. Effective January 1, 2007, upon
14 retirement all accumulated retirement insurance credits will be converted into cash
15 value at the rate of twelve (12) percent of the single plan rate in effect on the last day
16 worked with a cap of sixty-five (65) dollars per credit. (See Addendum No. 1 for
17 example of Subsection (f) benefits.) The rate will be reviewed during future contract
18 negotiations.
19

20 Employees who retire shall be credited with fifty-five dollars and seventy-three cents
21 (\$55.73) effective January 1, 2007, per month times the number of months from the
22 month after retirement until age sixty-five (65) or until eligible for Medicare or any
23 government-sponsored insurance whichever occurs first. Employees who retire shall
24 be credited with fifty-seven dollars and fifty-four cents (\$57.54) effective January 1,
25 2008, per month times the number of months from the month after retirement until
26 age sixty-five (65) or until eligible for Medicare or any government-sponsored
27 insurance whichever occurs first. Employees who retire shall be credited with fifty-
28 nine dollars and twenty-seven cents (\$59.27) effective January 1, 2009, per month
29 times the number of months from the month after retirement until age sixty-five (65)
30 or until eligible for Medicare or any government-sponsored insurance whichever
31 occurs first. Employees who retire shall be credited with sixty dollars and sixteen
32 cents (\$60.16) effective July 1, 2009, per month times the number of months from

1 the month after retirement until age sixty-five (65) or until eligible for Medicare or any
2 government-sponsored insurance whichever occurs first.

3
4 1. Upon retirement all credits and monies referred to in Subsection (F) shall be
5 placed into a City escrow account from which the retiree's premium for the
6 City's health insurance plan for retirees will be paid in an amount equal to the
7 cost of the lowest-priced single health insurance plan until age sixty-five (65)
8 or until said retiree becomes eligible for Medicare or any
9 government-sponsored insurance, dies, or until the account is exhausted,
10 whichever occurs first. A surviving spouse shall receive all retiree health
11 insurance benefits and credits earned by his/her spouse (surviving spouse
12 shall be treated as if he/she were the former employee).

13
14 2. Upon retirement, all said employees' sick days accumulated after January 1,
15 1985, which are accredited to the sick leave pool shall be removed from the
16 employees' sick leave accounts and the department's sick leave pool.

17
18 3. The intent of the Firefighters Retiree Health Insurance Good
19 Attendance/Retirement Program as it relates to one (1) retirement insurance
20 credit for each unused sick leave day is: For each unused sick leave day (8
21 hours) in Fire Department that is credited to the sick leave pool that is above
22 one hundred forty-four (144) base days pursuant to the Agreement initialed
23 on February 23, 1988, you will receive one (1) retirement insurance credit.
24 The intent being if you work a full month with no sick leave, you will receive
25 one (1) credit pursuant to the above requirements.

26
27 D. A surviving spouse of a deceased employee with fifteen (15) or more years of
28 continuous service in the Fire Department may participate at his or her own expense in
29 any City hospitalization plan covered by this Agreement provided he or she meets the
30 following conditions:

31
32 1. Marriage to the employee must have been for at least a five (5) year period.

1 **ARTICLE XXX**

2 **PENSIONS**

3
4 A. Effective 1/1/2016, each employee will contribute the yearly State-identified protected
5 employee contribution amount to the Wisconsin Retirement System of applicable wages
6 as determined by the Wisconsin Retirement System.

7
8 B. All such payments or contributions made by the City shall be reported to the Wisconsin
9 Retirement System in the same manner as though deducted from the earnings of the
10 participating employees; and all such payments or contributions made by the City shall
11 be available for all retirement fund benefit purposes to the same extent as normal
12 contributions which were deducted from the earnings of participating employees, it being
13 understood that such payment made by the City shall not be considered municipality
14 contributions.

15
16 C. **A deferred compensation plan** with the International City Management Association for
17 City employees shall be made available by a City of Sheboygan Resolution in
18 accordance with the Tax Report Act of 1978 (H.R. 13511). Wisconsin Deferred
19 Compensation Program and Nationwide will also be offered.

20
21 **ARTICLE XXXI**

22 **PHYSICALS**

23
24 Physical examinations may be required by the Fire Chief or his/her designee at any time at the
25 expense of the City; however, every member of the bargaining unit will be required to undergo
26 a physical examination from one (1) of three (3) doctors designated by the Fire Chief or his/her
27 designee at the City's expense during the following years of employment (These doctors may
28 be from one medical facility.): 16th year of employment, 26th year of employment, 32nd year of
29 employment, 38th year of employment, and 44th year of employment. None of the designated
30 doctors may be the member's own family physician. Such doctor shall furnish to the Fire Chief
31 or his/her designee the completed medical examination form provided by the City, copy of which
32 is attached hereto, certifying as to the physical and mental condition of the member so
33 examined.

ARTICLE XXXIV

TRAINING

- 1
- 2
- 3
- 4 A. **In-service training** shall be conducted during duty hours on City time.
- 5
- 6 B. The City will pay for tuition and textbooks within the budgetary limits to attend job-related
- 7 fire training courses as determined necessary by the Chief and upon approval of the Fire
- 8 Chief or his/her designee providing the employee satisfactorily completes said course.
- 9

10 In no event shall there be any payments of these benefits where an employee is eligible

11 for Veteran Administration benefits, grants, or other reimbursement for said tuition and

12 textbooks.

13

- 14 C. Each employee assumes full responsibility for learning and knowing the material
- 15 presented at training sessions and further agrees to maintain a level of professional
- 16 competence and physical and mental fitness necessary to perform the work assigned to
- 17 him/her.
- 18

- 19 D. Both parties to this Agreement recognize that physical fitness is of paramount
- 20 importance in the fire service. Persons employed in the fire service are expected and
- 21 frequently required to perform at emergencies under extremely high levels of physical
- 22 effort and stressful conditions. Physical fitness is a condition of employment.
- 23

- 24 E. In the event an employee who has been approved to attend outside training while on
- 25 duty is unable to do so due to insufficient staffing, the employee enjoys the right to
- 26 attend the class by making a trade under ARTICLE XXXIII. In the event an employee
- 27 makes a trade as described, the City will grant the employee who has covered the trade
- 28 time off at a later date under ARTICLE XXII.

29

1 **ARTICLE XXXV**

2 **NO OTHER AGREEMENT**

3
4 The City agrees not to enter into any other agreement, written or verbal, with bargaining
5 unit personnel, individually or collectively, which in any way conflicts with the provisions of this
6 Agreement or which usurps the Union's representative function.

7
8 **ARTICLE XXXVI**

9 **SAVINGS CLAUSE**

10
11 Each and every clause of this Agreement shall be deemed separable from each and every
12 other clause of this Agreement to the end that in the event that any clause or clauses shall be
13 finally determined to be in violation of any state or federal law, then and in such event such
14 clause or clauses only, to the extent only that any may be so in violation, shall be deemed of no
15 force and effect and unenforceable without impairing the validity and enforceability of the
16 rest of the Agreement, including any and all provisions in the remainder of any clause,
17 sentence, or paragraph in which offending language may appear. In the event of such contract
18 clause invalidation, both the City and the Union agree to meet within ten (10) days of such
19 determination and negotiate a valid clause reflecting the intent of the parties and to reach such
20 agreement concerning such valid clause within thirty (30) days. Said thirty (30) days may be
21 extended by mutual consent of both parties.

22
23 **ARTICLE XXXVII**

24 **WAIVERS**

25
26 The terms and conditions of this Agreement, or any breach thereof, can only be waived by
27 mutual agreement of the parties. Any such waiver shall not constitute a precedent in the future
28 enforcement of all its terms and conditions.

1
2
3
4
5
6
7
8
9
10
11
12
13
14
15
16
17
18
19
20
21
22
23
24
25
26
27
28
29
30
31
32
33

ARTICLE XXXIX

DURATION

- A. This Agreement shall be effective when signed by both parties and shall remain in full force and effect until its expiration date, December 31, 2017. This Agreement, reached as a result of collective bargaining, represents the full and complete agreements between the parties and supersedes all previous agreements between the parties. It is agreed that all matters which are referred to in this Agreement, and all matters which are not referred to in this Agreement but were either discussed during the negotiations which resulted in this Agreement or could have been discussed in such negotiations shall not be open for negotiations during the term of this Agreement, unless specifically provided for in this Agreement.
- B. On or before June 1, 2017, either party hereto may notify the other party in writing of its desire to negotiate the terms and provisions of a successor Agreement. Promptly following such notification, and specifically within the next one hundred and twenty (1) days, the parties hereto shall meet and engage in such negotiations.
- C. If neither party hereto gives notice to the other party of its desire to negotiate a successor Agreement prior to the expiration date of this Agreement as above provided, this Agreement shall automatically be renewed for successive one (1) year terms thereafter.

ARTICLE XXXX

RETROACTIVITY

- A. Retroactivity will be paid on increases in salary from January 1, 2018, until this contract is executed. All benefits will be retroactive to January 1, 2018, unless otherwise noted.
- B. All other changes in this Agreement shall be effective upon execution to be not later than ten (10) days after ratification by both parties, except where stated otherwise.

1 **Letter of Intent**

2
3 The following wording regarding the ability of a retired employee to change from a single plan to
4 a family plan was placed in the contract January 1, 2001:

5
6 "An employee may select either a family or single plan at retirement. Said retiree shall
7 be allowed to switch from single to family or from family to single as his/her personal
8 circumstances change. The retiree must notify the City of a change at least thirty (30)
9 days prior to implementation. This provision is subject to availability of this option by the
10 City's carrier and that change from single to family is limited to one (1) per retiree and
11 only in the event his/her spouse loses outside coverage."

12
13 **This Letter of Intent is to clarify that wording.**

14
15 **A.** This provision will take effect on January 1, 2001. As of that date, this wording shall cover
16 all current retirees and future retirees.

17 **B.** The option to change from a single to family plan can only be implemented once.

18 **C.** If a retiree's spouse has a loss of outside medical coverage from his/her place of
19 employment, the retiree can change his/her City plan from single to family.

20
21 **1.** The spouse can enter unconditionally upon completion of his/her COBRA rights with the
22 previous employer, or

23 **2.** The spouse may enter prior to the completion of COBRA with proof of insurability.

24 **3.** Should a retiree marry, he/she can change from a single plan to family if:

25
26 **a.** He/she has not already used the one-time single to family provisions previously.

27 **b.** The spouse is not eligible for employer-sponsored health insurance.

28 **c.** The spouse is not eligible for COBRA health insurance through a previous employer.

29 (Unless he/she provides proof of insurability (see #C.2.).

1 **D. Definitions.**

2

3 **1. Loss of outside medical coverage of an employee's spouse:** Circumstance which
4 leaves spouse without health insurance. Retirement, voluntary termination, involuntary
5 termination, layoff are examples of loss of outside medical coverage.

6 **2. COBRA.** The current law in effect which requires an employer to offer availability of
7 continued medical insurance in their plan following discontinuation of employment.

8 **3. Proof of insurability.** A medical examination to assure that there are not existing
9 medical conditions that would be exorbitantly expensive to the City Plan.

10

City of Sheboygan/Local 483 Contract

January 1, 2018 to December 31, 2020

Signed by the duly authorized representatives of the parties hereto, at Sheboygan, Wisconsin,
this 22nd day of FEBRUARY 2019.

FOR THE CITY

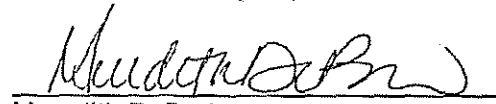

Michael Vandersteen
Mayor – City of Sheboygan

Meredith DeBruin
City Clerk – City of Sheboygan

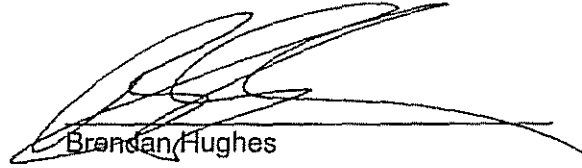
FOR LOCAL 483

Brendan Hughes
Union President

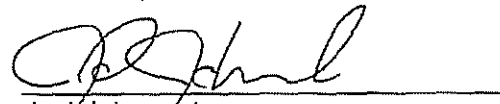
Matthew Polzin
Union Representative

Joel Johnson
Union Representative



William Cherek
Union Representative

EXHIBIT A

Part-time Work Report

Name _____ Date _____

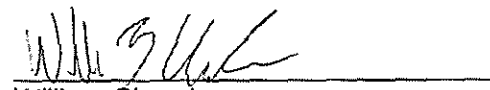
Place working and address _____

Type of work _____

Average hours worked (per week) _____

Time of day worked (day-night) _____

Can you be contacted for firefighting duty (yes-no) _____

Report made to (Chief, Dep. Chief) _____

Signed _____

FD-71

Addendum 1

EXAMPLE GOOD ATTENDANCE

**Retirement Analysis by Local 483, IAFF
(Rates Based on 1988 Labor Agreement)**

January 1/91 Single Rate HMP	194.32
Retirement Health Insurance	37.50
Good Attendance Bonus Rate	30.00

Example 1 (Near Retirement)

Regular Sick Leave	144	Severance Pay	
Medicare Age	65		
Retirement Age	55		
Available Months	120	37.50	4500.00
Credits Earned (1/85-1/88)	36	30.00	1080.00
Extended Illness			
0	30	0	0.5 0
		30.00	0.00
Total Sick Days Accumulated at Retirement	180	Credit	5580.00

Example 2 (Extension)

Regular Sick Leave	144	Severance Pay	
Medicare Age	65		
Retirement Age	58		
Available Months	84	37.50	3150.00
Credits Earned (1/85-1/91)	72	30.00	2160.00
Extended Illness			
0	30	0	0.5 0
		30.00	0.00
Total Sick Days Accumulated at Retirement	216	Credit	5310.00

City of Sheboygan/Local 483 Contract

January 1, 2018 to December 31, 2020

Example 3 (Illness Near Retirement)

Regular Sick Leave	76	Severance Pay	
Medicare Age	65		
Retirement Age	55		
Available Months	120	37.50	4500.00
Credits Earned (1/85-6/97)	150	30.00	4500.00
Extended Illness			
68	30	38	0.5 19 30.00 570.00
Total Sick Days Accumulated			
at Retirement	226	Credit	9570.00

Example 4 (Near Retirement 1 Credit Earned)

Regular Sick Leave	76	Severance Pay	
Medicare Age	65		
Retirement Age	58		
Available Months	84	37.50	3150.00
Credits Earned	1	30.00	30.00
Extended Illness			
68	30	38	0.5 19 30.00 570.00
Total Sick Days Accumulated			
at Retirement	77	Credit	3750.00

Example 5 (Early Retirement)

Regular Sick Leave	144	Severance Pay	
Medicare Age	65		
Retirement Age	51		
Available Months	168	37.50	6300.00
Credits Earned (1/85-1/94)	108	30.00	3240.00
Extended Illness			
0	30	0	0.5 0 30.00 0.00
Total Sick Days Accumulated			
at Retirement	252	Credit	9540.00

City of Sheboygan/Local 483 Contract

January 1, 2018 to December 31, 2020

Example 6 (25-year Employee)

Regular Sick Leave	144		Severance Pay
Medicare Age	65		
Retirement Age	55		
Available Months	120	37.50	4500.00
Credits Earned (1/85-6/97)	150	30.00	4500.00
Extended Illness			
	0 30 0 0.5 0	30.00	0.00
Total Sick Days Accumulated			
at Retirement	294	Credit	9000.00

Retirement Analysis by Local 483, IAFF

January 1/88 Single Rate Maxicare	80.58
Retirement Health Insurance	34.70
Good Attendance Bonus Rate	28.00

Example 1 (Near Retirement)

Regular Sick Leave	144		Severance Pay
Medicare Age	65		
Retirement Age	55		
Available Months	120	34.70	4164.00
Credits Earned (1/85-1/88)	36	28.00	1008.00
Extended Illness			
	0 30 0 0.5 0	28.00	0.00
Total Sick Days Accumulated			
at Retirement	180	Credit	5172.00

Example 2 (Extension)

Regular Sick Leave	144		Severance Pay
Medicare Age	65		
Retirement Age	58		
Available Months	84	34.70	2914.80

City of Sheboygan/Local 483 Contract

January 1, 2018 to December 31, 2020

Credits Earned (1/85-1/91)	72	28.00	2016.00
Extended Illness			
0	30	0 0.5 0	28.00 0.00
Total Sick Days Accumulated			
at Retirement	216	Credit	4930.80

Example 3 (Illness Near Retirement)

Regular Sick Leave	76	Severance Pay
Medicare Age	65	
Retirement Age	55	
Available Months	120	34.70 4164.00
Credits Earned (1/85-6/97)	150	28.00 4200.00
Extended Illness		
68	30	38 0.5 19 28.00 532.00
Total Sick Days Accumulated		
at Retirement	226	Credit 8896.00

Example 4 (Near Retirement 1 Credit Earned)

Regular Sick Leave	76	Severance Pay
Medicare Age	65	
Retirement Age	58	
Available Months	84	34.70 2914.80
Credits Earned	1	28.00 28.00
Extended Illness		
68	30	38 0.5 19 28.00 532.00
Total Sick Days Accumulated		
at Retirement	77	Credit 3474.80

Example 5 (Early Retirement)

Regular Sick Leave	144	Severance Pay
Medicare Age	65	
Retirement Age	51	
Available Months	168	34.70 5829.60
Credits Earned (1/85-1/94)	108	28.00 3024.00
Extended Illness		

City of Sheboygan/Local 483 Contract

January 1, 2018 to December 31, 2020

0	30	0	0.5	0	28.00	0.00
Total Sick Days Accumulated						
at Retirement		252			Credit	8853.60

Example 6 (25-year Employee)

Regular Sick Leave	144				Severance Pay	
Medicare Age	65					
Retirement Age	55					
Available Months	120				34.70	4164.00
Credits Earned (1/85-6/97)	150				28.00	4200.00
Extended Illness						
0	30	0	0.5	0	28.00	0.00
Total Sick Days Accumulated						
at Retirement		294			Credit	8364.00

1

City of Sheboygan/Local 483 Contract

January 1, 2018 to December 31, 2020

INDEX

Additional Duty	15
Agreement	4
Arbitration	26
Arbitration - Expenses	26
Arbitration - Selection of Impartial Arbitrator	26
Arbitration Clause	7
Base Pay and Longevity Plan	33
Bereavement Leave	32
Call Back	10
Compensatory Time	9
Compensatory Time - FLSA Accrual	9
Holidays	39
Compensatory Time - Use of	9
Deferred Compensation Plan	66
Definitions - Immediate Family	57
Definitions - Kelly Day	7
Definitions - Retiree	63
Definitions - Tour of Duty	7
Definitions - W.E.R.C.	7
Dental Insurance	65
Direct Deposit	38
Duration	71
Duty Incurred Disability	60
EMS	70
Extended Shift	11
Fire Equipment Operator Certification	18
Grievance Procedure - Arbitration	26
Grievance Procedure - General Provisions	24
Grievance Procedure - Exempt Items	24
Grievance Procedure - Job Classifications, Promotional Procedures	24
Grievance Procedure - Pension Matters	24
Grievance Procedure - Steps	25
Health Insurance - Double Coverage	
Health Insurance - Good Attendance Example	76
Health Insurance - Good Attendance Retirement Bonus Program	63
Health Insurance - Retiree Insurance Credit	64

City of Sheboygan/Local 483 Contract

January 1, 2018 to December 31, 2020

Health Insurance - Retirees Participation	62
Health Insurance - Surviving Spouse	62,64
Holiday Pay - Compensatory Time	39
Holiday Pay - Fifty Six Hour Per Week	15,39
Holiday Pay - Forty Hour Per Week Employees	16,39
Instructor Premium Pay	43
Lay Off and Recall	21
Leaves of Absence	31
Light Duty	60
Life Insurance	65
Longevity	33
Loss of Seniority	23
Loss or Damage	67
Military Service	55
No Other Agreement	69
Normal Workweek	8
No Pyramiding, Duplicating, or Compounding	16
Overtime	9
Paramedic Pay	70
Paramedic Preceptor Compensation	45
Part Time Work Report	23,75
Pensions - Deferred Compensation Plan	66
Pensions - Wisconsin Retirement System	66
Physicals	66
Probation	21
Prohibition of Strikes	28
Promotions and Transfers - Eligibility Lists	17,19
Promotions and Transfers - Firefighter and FEO to Lieutenant	17
Promotions and Transfers - Lieutenant to Captain	17
Promotions and Transfers - Transfers	20
Recognition	5
Residency Requirement	6
Retroactivity	71
Rights of Management	6
Rules and Regulations	30
Salary and Wage Schedule	37
Savings Clause	69
Severance Pay	46

City of Sheboygan/Local 483 Contract

January 1, 2018 to December 31, 2020

Sick Leave	56
Sick Leave Pool	56
Sick Leave Pool Upon Retirement	59
Special Salary Provisions	41
Staffing Shortage	11
Stand By	11
Time Trades	67
Training	45,68
Transfers	20
Two (2) Week Holdback Pay	38
Uniform Allowance	40
Uniform Allowance - Protective Clothing	40
Union Activities	54
Union Dues	5
Union Security	5
Vacation	49
Vacation - FLSA and Regular Compensatory Time - EMS Day	50,70
Waivers	69
Witnesseth	4

City of Sheboygan/Local 483 Contract

January 1, 2018 to December 31, 2020

Addendum 3

Pay Schedules

City of Sheboygan
 Fire Department - "H" Pay Schedule - 2018
 2.0% Increase Effective 01/01/2018
 All Grades Bi-Weekly Salary Based on 80 Hours
 Annual Salary Based on 26 Paydays
 Longevity = 1.5%, 3.0%, 4.5%, 6.0%, 7.5%

		BASE SALARY RATES							LONGEVITY RATES					
		HIRING RATE	AFTER 1 YEAR	AFTER 2 YEARS	AFTER 3 YEARS	AFTER 4 YEARS	AFTER 5 YEARS	AFTER 6 YEARS	AFTER 7 YEARS	After 7 Yrs Svc & 1 Yr Ø MAXIMUM RATE 1.50%	After 10 Yrs Svc & 1 Yr Ø MAXIMUM RATE 3.00%	After 15 Yrs Svc & 1 Yr Ø MAXIMUM RATE 4.50%	After 20 Yrs Svc & 1 Yr Ø MAXIMUM RATE 6.00%	After 25 Yrs Svc & 1 Yr Ø MAXIMUM RATE 7.50%
		Step1	Step 2	Step 3	Step 4	Step 5	Step 6	Step 7	Step 8	Step 9	Step 10	Step 11	Step 12	
Firefighter/Paramedic	Grade 1	Hourly Rate	21.6953	23.4974	25.3112	27.1133	28.9271	30.7290	32.8728	33.3659	33.8589	34.3520	34.8451	35.3381
	Bi-Weekly Pay	1,735.62	1,879.79	2,024.89	2,169.06	2,314.17	2,458.32	2,629.82	2,669.27	2,708.71	2,748.16	2,787.61	2,827.05	
	Holiday Pay	102.40	110.91	119.47	127.97	136.54	145.04	155.16	157.49	159.81	162.14	164.47	166.80	
	Bi-Weekly + Holiday	1,838.02	1,990.70	2,144.36	2,297.03	2,450.71	2,603.36	2,784.98	2,826.76	2,868.52	2,910.30	2,952.08	2,993.85	
	Monthly Pay	3,760.51	4,072.88	4,387.27	4,699.63	5,014.04	5,326.36	5,697.94	5,783.42	5,868.87	5,954.35	6,039.82	6,125.28	
	Monthly + Holiday	3,982.38	4,313.18	4,646.12	4,976.91	5,309.66	5,640.82	6,034.12	6,124.64	6,215.14	6,305.65	6,396.17	6,486.67	
	Annual Pay	45,126.12	48,874.54	52,647.24	56,395.56	60,168.42	63,916.32	68,375.32	69,401.02	70,426.46	71,452.16	72,477.86	73,503.30	
	Annual + Holiday	47,788.56	51,758.14	55,753.43	59,722.90	63,718.36	67,687.39	72,409.46	73,495.68	74,581.62	75,667.84	76,754.05	77,839.99	
Equipment Operator	Grade 2	Hourly Rate	22.1194	23.9686	25.8059	27.6550	29.4924	31.3415	33.5323	34.0354	34.5383	35.0413	35.5443	36.0471
	Bi-Weekly Pay	1,769.55	1,917.49	2,064.47	2,212.40	2,359.39	2,507.32	2,682.58	2,722.83	2,763.06	2,803.30	2,843.54	2,883.77	
	Holiday Pay	104.40	113.13	121.80	130.53	139.20	147.93	158.27	160.65	163.02	165.39	167.77	170.14	
	Bi-Weekly + Holiday	1,873.95	2,030.62	2,186.27	2,342.93	2,498.59	2,655.25	2,840.85	2,883.48	2,926.08	2,968.69	3,011.31	3,053.91	
	Monthly Pay	3,834.03	4,154.56	4,473.02	4,793.53	5,112.01	5,432.53	5,812.26	5,899.47	5,986.63	6,073.82	6,161.00	6,248.17	
	Monthly + Holiday	4,050.23	4,399.68	4,736.93	5,076.35	5,413.62	5,753.05	6,155.18	6,247.53	6,339.84	6,432.17	6,524.50	6,616.81	
	Annual Pay	46,008.30	49,854.54	53,676.22	57,522.40	61,344.14	65,160.32	69,747.08	70,793.58	71,839.58	72,885.60	73,932.04	74,978.02	
	Annual + Holiday	48,722.79	52,766.17	56,843.12	60,916.22	64,963.44	69,036.55	73,862.16	74,970.40	76,076.09	77,186.06	78,294.03	79,401.72	
Lieutenant	Grade 4	Hourly Rate	28.1959	29.3040	30.4110	31.5183	32.6254	33.7443	34.8514	35.3743	35.8970	36.4198	36.9425	37.4653
	Bi-Weekly Pay	2,255.75	2,344.32	2,432.88	2,521.46	2,610.03	2,699.59	2,788.11	2,829.94	2,871.76	2,913.58	2,955.40	2,997.22	
	Holiday Pay	133.09	138.31	143.54	148.77	153.99	159.22	164.50	166.97	169.43	171.90	174.37	176.84	
	Bi-Weekly + Holiday	2,388.84	2,482.63	2,576.42	2,670.23	2,764.02	2,858.81	2,952.61	2,996.91	3,041.19	3,085.48	3,129.77	3,174.06	
	Monthly Pay	4,007.46	5,079.36	5,271.24	5,463.16	5,655.07	5,849.00	6,040.91	6,131.54	6,222.15	6,312.76	6,403.37	6,493.98	
	Monthly + Holiday	5,175.82	5,379.04	5,582.24	5,785.49	5,988.71	6,194.09	6,397.32	6,493.30	6,589.25	6,685.21	6,781.17	6,877.12	
	Annual Pay	58,549.50	60,952.32	63,254.88	65,557.96	67,860.78	70,188.04	72,490.86	73,578.44	74,665.76	75,753.08	76,840.40	77,927.72	
	Annual + Holiday	62,109.82	64,548.51	66,986.92	69,425.88	71,864.57	74,329.13	76,767.82	77,919.57	79,071.04	80,222.51	81,373.98	82,525.46	
Captain	Grade 5	Hourly Rate	30.1284	31.3415	32.5548	33.7679	34.9809	36.1943	37.4073	37.9584	38.5295	39.0906	39.6518	40.2129
	Bi-Weekly Pay	2,410.27	2,507.32	2,604.38	2,701.43	2,798.47	2,895.54	2,992.59	3,037.47	3,082.36	3,127.25	3,172.14	3,217.03	
	Holiday Pay	142.21	147.93	153.66	159.38	165.11	170.84	176.56	179.21	181.86	184.51	187.16	189.80	
	Bi-Weekly + Holiday	2,552.48	2,655.25	2,758.04	2,860.81	2,963.58	3,066.38	3,169.14	3,216.68	3,264.22	3,311.76	3,359.30	3,406.83	
	Monthly Pay	5,222.25	5,432.53	5,642.82	5,853.10	6,063.35	6,273.67	6,483.92	6,581.19	6,678.45	6,775.71	6,872.97	6,970.23	
	Monthly + HP	5,530.36	5,753.05	5,975.75	6,198.43	6,421.09	6,643.82	6,866.47	6,969.47	7,072.48	7,175.48	7,278.48	7,381.48	
	Annual Pay	62,667.02	65,190.32	67,713.88	70,237.18	72,760.22	75,284.04	77,807.09	78,974.22	80,141.36	81,308.50	82,475.64	83,642.78	
	Annual + Holiday	66,364.37	69,036.55	71,709.00	74,381.17	77,053.07	79,725.60	82,397.70	83,633.70	84,869.70	86,105.70	87,341.70	88,577.70	

HOLIDAY PAY = BI-WEEKLY RATE/10 X 15.3326; MUNIS CALCULATION = BI-WEEKLY PAY X .053

City of Sheboygan
 Fire Department - "H" Pay Schedule - 2019
 2.25% Increase Effective 01/01/2019
 All Grades Bi-Weekly Salary Based on 60 Hours
 Annual Salary Based on 26 Paydays
 Longevity = 1.5%, 3.0%, 4.5%, 6.0%, 7.5%

		BASE SALARY RATES						LONGEVITY RATES						
		HIRING RATE	AFTER 1 YEAR	AFTER 2 YEARS	AFTER 3 YEARS	AFTER 4 YEARS	AFTER 5 YEARS	AFTER 6 YEARS	AFTER 7 Yrs Svc & 1 Yr O	After 10 Yrs Svc & 1 Yr O	After 15 Yrs Svc & 1 Yr O	After 20 Yrs Svc & 1 Yr O	After 25 Yrs Svc & 1 Yr O	
									MAXIMUM RATE	MAXIMUM RATE	MAXIMUM RATE	MAXIMUM RATE	MAXIMUM RATE	
									1.50%	3.00%	4.50%	6.00%	7.50%	
		Step 1	Step 2	Step 3	Step 4	Step 5	Step 6	Step 7	Step 8	Step 9	Step 10	Step 11	Step 12	
Firefighter/Paramedic	Grade 1	Hourly Rate	22.1834	24.0261	25.8606	27.7233	29.5780	31.4204	33.6124	34.1166	34.6208	35.1249	35.6291	36.1333
		Bi-Weekly Pay	1,774.67	1,922.09	2,070.45	2,217.89	2,366.24	2,513.63	2,668.99	2,729.33	2,769.66	2,809.99	2,850.33	2,890.66
		Holiday Pay	104.71	113.40	122.16	130.85	139.61	148.30	158.65	161.03	163.41	165.79	168.17	170.55
		Bi-Weekly + Holiday	1,879.38	2,035.49	2,192.61	2,348.71	2,505.85	2,661.93	2,847.64	2,890.36	2,933.07	2,975.78	3,018.50	3,061.21
		Monthly Pay	3,845.12	4,164.53	4,485.98	4,805.36	5,126.85	5,446.20	5,826.15	5,913.65	6,000.93	6,088.31	6,175.72	6,263.10
		Monthly + Holiday	4,071.98	4,410.24	4,750.65	5,088.88	5,429.34	5,767.52	6,169.89	6,262.45	6,354.98	6,447.52	6,540.08	6,632.62
		Annual Pay	46,141.42	49,974.34	53,831.70	57,664.36	61,522.24	65,354.38	69,913.74	70,962.58	72,011.16	73,059.74	74,108.58	75,157.16
		Annual + Holiday	48,863.76	52,922.83	57,007.77	61,066.56	65,152.05	69,210.29	74,038.65	75,149.37	76,258.82	77,370.26	78,480.99	79,591.43
Equipment Operator	Grade 2	Hourly Rate	22.6170	24.5079	26.3865	28.2773	30.1560	32.0466	34.2868	34.8011	35.3154	35.8296	36.3440	36.8581
		Bi-Weekly Pay	1,809.36	1,960.63	2,110.92	2,262.18	2,412.48	2,563.73	2,742.94	2,784.09	2,825.23	2,866.37	2,907.52	2,948.65
		Holiday Pay	106.75	115.68	124.54	133.47	142.34	151.26	161.83	164.26	166.69	169.12	171.54	173.97
		Bi-Weekly + Holiday	1,916.11	2,076.31	2,235.46	2,395.65	2,554.82	2,714.99	2,904.77	2,948.35	2,991.92	3,035.49	3,079.06	3,122.62
		Monthly Pay	3,920.28	4,248.03	4,573.66	4,901.39	5,227.04	5,554.75	5,943.04	6,032.20	6,121.33	6,210.47	6,299.63	6,388.74
		Monthly + Holiday	4,151.59	4,498.67	4,843.51	5,190.57	5,535.44	5,882.48	6,293.68	6,388.09	6,482.49	6,576.89	6,671.30	6,765.68
		Annual Pay	47,043.36	50,976.38	54,893.92	58,816.68	62,724.48	66,656.99	71,316.44	72,386.34	73,455.98	74,525.62	75,595.52	76,664.90
		Annual + Holiday	49,816.92	53,983.99	58,122.07	62,266.86	66,425.22	70,589.74	75,524.11	76,657.13	77,789.88	78,922.63	80,055.66	81,188.13
Lieutenant	Grade 4	Hourly Rate	28.8313	29.9634	31.0953	32.2274	33.3595	34.5035	35.6355	36.1701	36.7046	37.2393	37.7738	38.3083
		Bi-Weekly Pay	2,306.50	2,397.07	2,487.62	2,578.19	2,668.76	2,760.28	2,850.84	2,893.61	2,936.37	2,979.14	3,021.90	3,064.66
		Holiday Pay	136.08	141.43	146.77	152.11	157.46	162.86	168.20	170.72	173.25	175.77	178.29	180.81
		Bi-Weekly + Holiday	2,442.58	2,538.50	2,634.39	2,730.30	2,826.22	2,923.14	3,019.04	3,064.33	3,109.62	3,154.91	3,200.19	3,245.47
		Monthly Pay	4,937.42	5,193.65	5,389.84	5,566.08	5,782.31	5,980.61	6,176.82	6,269.49	6,362.14	6,454.80	6,547.45	6,640.10
		Monthly + Holiday	5,292.26	5,500.08	5,707.84	5,915.66	6,123.47	6,333.46	6,541.25	6,639.39	6,737.50	6,835.64	6,933.75	7,031.86
		Annual Pay	59,969.00	62,323.82	64,678.12	67,032.94	69,387.76	71,767.28	74,121.84	75,233.85	76,345.82	77,457.64	78,569.40	79,681.16
		Annual + Holiday	63,507.17	66,000.93	68,494.13	70,987.88	73,481.64	76,001.55	78,495.03	79,672.66	80,850.01	82,027.64	83,204.99	84,382.35
Captain	Grade 5	Hourly Rate	30.8063	32.0466	33.2873	34.5276	35.7680	37.0086	38.2489	38.8226	39.3964	39.9701	40.5439	41.1176
		Bi-Weekly Pay	2,464.50	2,563.73	2,662.98	2,762.21	2,861.44	2,960.69	3,059.91	3,105.81	3,151.71	3,197.61	3,243.51	3,289.41
		Holiday Pay	145.41	151.26	157.12	162.97	168.82	174.68	180.53	183.24	185.95	188.66	191.37	194.08
		Bi-Weekly + Holiday	2,609.91	2,714.99	2,820.10	2,925.18	3,030.26	3,135.37	3,240.44	3,289.05	3,337.66	3,386.27	3,434.88	3,483.49
		Monthly Pay	5,339.75	5,554.75	5,769.79	5,984.79	6,199.79	6,414.83	6,629.81	6,729.26	6,828.71	6,928.16	7,027.61	7,127.06
		Monthly + HP	5,654.80	5,882.48	6,110.21	6,337.89	6,565.57	6,793.30	7,020.96	7,126.28	7,231.60	7,336.92	7,442.23	7,547.55
		Annual Pay	64,077.00	66,656.98	69,237.48	71,817.46	74,397.44	76,977.94	79,557.66	80,751.06	81,944.46	83,137.86	84,331.26	85,524.66
		Annual + Holiday	67,057.54	70,589.74	73,322.49	76,054.69	78,786.89	81,519.64	84,251.56	85,515.37	86,779.18	88,042.99	89,306.80	90,570.61

HOLIDAY PAY = BI-WEEKLY RATE/10 X 15.3326; MUNIS CALCULATION = BI-WEEKLY PAY X .059

City of Sheboygan
 Fire Department - "H" Pay Schedule - 2020
 2.0% Increase Effective 01/01/2020
 All Grades Bi-Weekly Salary Based on 80 Hours
 Annual Salary Based on 26 Paydays
 Longevity = 1.5%, 3.0%, 4.5%, 6.0%, 7.5%

BASE SALARY RATES								LONGEVITY RATES						
HIRING RATE	AFTER 1 YEAR	AFTER 2 YEARS	AFTER 3 YEARS	AFTER 4 YEARS	AFTER 5 YEARS	AFTER 6 YEARS	After 7 Yrs	After 10 Yrs	After 15 Yrs	After 20 Yrs	After 25 Yrs			
							Svc & 1 Yr @	Svc & 1 Yr @	Svc & 1 Yr @	Svc & 1 Yr @	Svc & 1 Yr @			
							MAXIMUM RATE	MAXIMUM RATE	MAXIMUM RATE	MAXIMUM RATE	MAXIMUM RATE			
							1.50%	3.00%	4.50%	6.00%	7.50%			
								Step 8	Step 9	Step 10	Step 11	Step 12		
Firefighter/Paramedic	Grade 1	Hourly Rate	22.6270	24.5066	26.3983	28.2778	30.1695	32.0488	34.2846	34.7990	35.3131	35.8274	36.3418	36.8559
		Bi-Weekly Pay	1,810.16	1,960.53	2,111.86	2,262.22	2,413.56	2,563.90	2,742.77	2,783.92	2,825.05	2,866.19	2,907.34	2,948.47
		Holiday Pay	106.80	115.67	124.60	133.47	142.40	151.27	161.82	164.25	166.68	169.11	171.53	173.96
		Bi-Weekly + Holiday	1,916.96	2,076.20	2,236.46	2,395.69	2,555.96	2,715.17	2,904.59	2,948.17	2,991.73	3,035.30	3,078.87	3,122.43
		Monthly Pay	3,922.01	4,247.82	4,575.70	4,901.48	5,229.38	5,555.12	5,942.67	6,031.83	6,120.94	6,210.08	6,299.24	6,388.35
		Monthly + Holiday	4,153.41	4,498.44	4,845.66	5,190.66	5,537.91	5,882.87	6,293.29	6,387.70	6,482.08	6,576.47	6,670.89	6,765.26
		Annual Pay	47,064.16	50,973.78	54,908.36	58,817.72	62,752.56	66,661.40	71,312.02	72,381.92	73,451.30	74,520.94	75,590.64	76,660.22
		Annual + Holiday	49,840.95	53,981.23	58,147.95	62,287.97	66,454.96	70,594.42	75,519.43	76,552.45	77,784.93	78,917.68	80,050.70	81,183.17
Equipment Operator	Grade 2	Hourly Rate	23.0694	24.9980	26.9143	28.8428	30.7591	32.6875	34.9725	35.4971	36.0216	36.5463	37.0709	37.5953
		Bi-Weekly Pay	1,845.55	1,999.84	2,153.14	2,307.42	2,460.73	2,615.00	2,797.80	2,839.77	2,881.73	2,923.70	2,965.67	3,007.62
		Holiday Pay	108.89	117.89	127.04	136.14	145.18	154.29	165.07	167.55	170.02	172.50	174.97	177.45
		Bi-Weekly + Holiday	1,954.44	2,117.83	2,280.18	2,443.56	2,605.91	2,769.29	2,962.87	3,007.32	3,051.75	3,096.20	3,140.64	3,185.07
		Monthly Pay	3,938.69	4,332.99	4,665.14	4,999.41	5,331.58	5,665.83	6,061.90	6,152.84	6,243.75	6,334.68	6,425.62	6,516.51
		Monthly + Holiday	4,234.61	4,588.63	4,940.38	5,294.38	5,646.14	6,000.12	6,419.55	6,515.85	6,612.13	6,708.43	6,804.73	6,900.98
		Annual Pay	47,984.30	51,895.84	55,981.64	59,932.92	63,978.96	67,990.00	72,742.60	73,834.02	74,924.98	76,016.20	77,107.42	78,198.12
		Annual + Holiday	50,815.37	55,063.59	59,284.56	63,532.50	67,753.74	72,001.41	77,034.63	78,190.23	79,345.55	80,501.16	81,656.76	82,811.81
Lieutenant	Grade 4	Hourly Rate	29.4079	30.5626	31.7171	32.8719	34.0268	35.1936	36.3483	36.8935	37.4388	37.9840	38.5293	39.0744
		Bi-Weekly Pay	2,352.63	2,445.01	2,537.37	2,629.75	2,722.14	2,815.49	2,907.86	2,951.48	2,995.10	3,038.72	3,082.34	3,125.95
		Holiday Pay	138.81	144.26	149.70	155.16	160.61	166.11	171.56	174.14	176.71	179.28	181.86	184.43
		Bi-Weekly + Holiday	2,491.44	2,589.27	2,687.07	2,784.91	2,882.75	2,981.60	3,079.42	3,125.62	3,171.81	3,218.00	3,264.20	3,310.38
		Monthly Pay	5,097.37	5,297.52	5,497.64	5,697.79	5,897.97	6,100.23	6,300.36	6,394.87	6,489.38	6,583.89	6,678.40	6,772.89
		Monthly + Holiday	5,398.11	5,610.08	5,822.00	6,033.96	6,245.95	6,460.14	6,672.08	6,772.17	6,872.26	6,972.34	7,072.43	7,172.49
		Annual Pay	61,168.38	63,570.26	65,971.62	68,373.50	70,775.64	73,202.74	75,604.36	76,738.48	77,872.60	79,006.72	80,140.84	81,274.70
		Annual + Holiday	64,777.31	67,320.91	69,863.95	72,407.54	74,951.40	77,521.70	80,065.02	81,266.05	82,467.08	83,668.12	84,869.15	86,069.91
Captain	Grade 5	Hourly Rate	31.4224	32.6875	33.9530	35.2181	36.4834	37.7488	39.0139	39.5991	40.1843	40.7695	41.3548	41.9400
		Bi-Weekly Pay	2,513.79	2,615.00	2,716.24	2,817.45	2,918.67	3,019.90	3,121.11	3,167.93	3,214.74	3,261.55	3,308.38	3,355.20
		Holiday Pay	148.31	154.29	160.26	166.23	172.20	178.17	184.15	186.91	189.67	192.43	195.19	197.96
		Bi-Weekly + Holiday	2,662.10	2,769.29	2,876.50	2,983.68	3,090.87	3,198.07	3,305.26	3,354.84	3,404.41	3,453.99	3,503.57	3,553.16
		Monthly Pay	5,446.55	5,665.83	5,885.19	6,104.48	6,323.79	6,543.12	6,762.41	6,863.85	6,965.27	7,066.71	7,168.16	7,269.60
		Monthly + HP	5,767.89	6,000.12	6,232.41	6,464.64	6,696.89	6,929.16	7,161.39	7,268.82	7,376.22	7,483.65	7,591.09	7,698.51
		Annual Pay	65,358.54	67,990.00	70,622.24	73,253.70	75,885.42	78,517.40	81,148.86	82,356.18	83,503.24	84,600.56	85,617.88	87,235.20
		Annual + Holiday	69,214.69	72,001.41	74,789.95	77,575.67	80,352.66	83,149.93	85,938.64	87,225.78	88,514.65	89,803.79	91,092.93	92,382.08

HOLIDAY PAY = BI-WEEKLY RATE/10 X 15.3326; MUNIS CALCULATION = BI-WEEKLY PAY X .059

City of Sheboygan
 Fire Department - "F" Pay Schedule - 2018
 2.0% Increase Effective 01/01/2018 (01/26/18 Payroll)
 All Grades Bi-Weekly Salary Based on 80 Hours
 Annual Salary Based on 26 Paydays
 Longevity = 1.5%, 3.0%, 4.5%, 6.0%, 7.5%

		BASE SALARY RATES					LONGEVITY RATES				
		HIRING RATE	AFTER 1 YEAR	AFTER 2 YEARS	AFTER 3 YEARS	AFTER 4 YEARS	After 5 Yrs Svc & 1 Yr @ MAXIMUM RATE 1.50%	After 10 Yrs Svc & 1 Yr @ MAXIMUM RATE 3.00%	After 15 Yrs Svc & 1 Yr @ MAXIMUM RATE 4.50%	After 20 Yrs Svc & 1 Yr @ MAXIMUM RATE 6.00%	After 25 Yrs Svc & 1 Yr @ MAXIMUM RATE 7.50%
		Step 1	Step 2	Step 3	Step 4	Step 5	Step 6	Step 7	Step 8	Step 9	Step 10
Firefighter/Paramedic	Grade 1	Hourly Rate				31.6243	32.0986	32.5729	33.0474	33.5216	33.9961
		Bi-Weekly Pay				2,529.94	2,567.89	2,605.83	2,643.79	2,681.73	2,719.69
		Holiday Pay				149.27	151.51	153.74	155.98	158.22	160.46
		Bi-Weekly + Holiday				2,679.21	2,719.40	2,759.57	2,799.77	2,839.95	2,880.15
		Monthly Pay				5,481.54	5,563.76	5,645.97	5,728.21	5,810.42	5,892.65
		Monthly + Holiday				5,804.55	5,892.02	5,979.08	6,066.18	6,153.23	6,240.33
		Annual Pay				65,778.44	66,765.14	67,751.58	68,738.54	69,724.98	70,711.94
	Annual + Holiday				69,659.37	70,704.28	71,748.92	72,794.11	73,838.75	74,883.94	
Equipment Operator	Grade 2	Hourly Rate	22.1194	23.9685	25.8059	27.6550	32.7321	33.2159	33.6996	34.1834	34.6671
		Bi-Weekly Pay	1,769.55	1,917.48	2,064.47	2,212.40	2,618.57	2,657.27	2,695.97	2,734.67	2,773.37
		Holiday Pay	104.40	113.13	121.80	130.53	154.50	156.78	159.06	161.35	163.63
		Bi-Weekly + Holiday	1,873.95	2,030.61	2,186.27	2,342.93	2,773.07	2,814.05	2,855.03	2,896.02	2,937.00
		Monthly Pay	3,834.03	4,154.54	4,473.02	4,793.53	5,673.57	5,757.42	5,841.27	5,925.12	6,008.97
		Monthly + Holiday	4,060.23	4,399.66	4,738.93	5,076.35	6,008.31	6,097.11	6,185.50	6,274.70	6,363.50
		Annual Pay	46,008.30	49,854.48	53,676.22	57,522.40	68,082.82	69,089.02	70,095.22	71,101.42	72,107.62
	Annual + Holiday	48,722.79	52,795.89	55,843.12	60,916.22	72,099.71	73,165.27	74,230.84	75,296.40	76,361.97	
Lieutenant	Grade 4	Hourly Rate	28.2675	31.1178	32.1660	33.2379	35.3743	35.8970	36.4198	36.9425	37.4653
		Bi-Weekly Pay	2,261.40	2,489.42	2,573.28	2,659.03	2,829.84	2,871.76	2,913.58	2,955.40	2,997.22
		Holiday Pay	133.42	146.88	151.82	156.88	166.97	169.43	171.90	174.37	176.84
		Bi-Weekly + Holiday	2,394.82	2,636.30	2,725.10	2,815.91	2,996.91	3,041.19	3,085.48	3,129.77	3,174.06
		Monthly Pay	4,899.70	5,392.74	5,575.44	5,761.23	6,131.54	6,222.15	6,312.76	6,403.37	6,493.98
		Monthly + Holiday	5,188.78	5,711.97	5,904.39	6,101.14	6,493.30	6,589.25	6,685.21	6,781.17	6,877.12
		Annual Pay	58,796.40	64,724.92	66,905.28	69,134.78	73,578.44	74,665.76	75,753.08	76,840.40	77,927.72
	Annual + Holiday	62,265.39	68,543.69	70,852.69	73,213.73	77,919.57	79,071.04	80,222.51	81,373.98	82,525.46	
Captain	Grade 5	Hourly Rate	30.1891	33.2849	34.5451	35.7230	37.9684	38.5295	39.0906	39.6516	40.2129
		Bi-Weekly Pay	2,415.93	2,662.79	2,763.61	2,857.84	3,037.47	3,082.36	3,127.25	3,172.13	3,217.03
		Holiday Pay	142.54	157.10	163.05	168.61	179.21	181.86	184.51	187.16	189.80
		Bi-Weekly + Holiday	2,558.47	2,819.89	2,926.66	3,026.45	3,216.68	3,264.22	3,311.76	3,359.29	3,406.83
		Monthly Pay	5,234.52	5,789.38	5,987.82	6,191.99	6,581.19	6,678.45	6,775.71	6,872.95	6,970.23
		Monthly + HP	5,543.35	6,109.77	6,341.10	6,557.31	6,969.47	7,072.48	7,175.48	7,278.45	7,381.48
		Annual Pay	62,814.18	69,232.54	71,853.85	74,303.84	78,974.22	80,141.36	81,308.50	82,475.38	83,642.78
	Annual + Holiday	66,520.22	73,317.28	76,093.24	78,687.77	83,633.70	84,669.70	85,705.70	86,741.43	87,777.70	

City of Sheboygan
 Fire Department - "F" Pay Schedule - 2019
 2.25% Increase Effective 01/01/2019 (01/25/19 Payroll)
 All Grades Bi-Weekly Salary Based on 80 Hours
 Annual Salary Based on 26 Paydays
 Longevity = 1.5%, 3.0%, 4.5%, 6.0%, 7.5%

		BASE SALARY RATES					LONGEVITY RATES					
		HIRING RATE	AFTER 1 YEAR	AFTER 2 YEARS	AFTER 3 YEARS	AFTER 4 YEARS	After 5 Yrs Svc & 1 Yr @ MAXIMUM RATE 1.50%	After 10 Yrs Svc & 1 Yr @ MAXIMUM RATE 3.00%	After 15 Yrs Svc & 1 Yr @ MAXIMUM RATE 4.50%	After 20 Yrs Svc & 1 Yr @ MAXIMUM RATE 6.00%	After 25 Yrs Svc & 1 Yr @ MAXIMUM RATE 7.50%	
		Step 1	Step 2	Step 3	Step 4	Step 5	Step 6	Step 7	Step 8	Step 9	Step 10	
Firefighter/Paramedic	Grade 1	Hourly Rate				32.3358	32.8209	33.3058	33.7910	34.2759	34.7610	
	Bi-Weekly Pay					2,586.86	2,625.67	2,664.45	2,703.28	2,742.07	2,780.88	
	Holiday Pay					152.62	154.91	157.20	159.49	161.78	164.07	
	Bi-Weekly + Holiday					2,739.48	2,780.58	2,821.66	2,862.77	2,903.85	2,944.95	
	Monthly Pay					5,604.86	5,688.95	5,773.03	5,857.11	5,941.15	6,025.24	
	Monthly + Holiday					5,935.55	6,024.60	6,113.60	6,202.68	6,291.68	6,380.73	
	Annual Pay					67,256.36	68,267.42	69,275.96	70,285.28	71,293.82	72,302.88	
	Annual + Holiday					71,226.50	72,295.20	73,363.24	74,432.11	75,500.16	76,568.75	
	Equipment Operator	Grade 2	Hourly Rate	22.6170	24.5078	26.3865	28.2773	32.9741	33.4686	33.9633	34.4579	34.9525
	Bi-Weekly Pay	1,809.36	1,960.62	2,110.92	2,262.18	2,637.93	2,677.49	2,717.06	2,756.63	2,796.20	2,835.77	
Holiday Pay	106.75	115.68	124.54	133.47	155.64	157.97	160.31	162.64	164.98	167.31		
Bi-Weekly + Holiday	1,916.11	2,076.30	2,235.46	2,395.65	2,793.57	2,835.46	2,877.37	2,919.27	2,961.18	3,003.08		
Monthly Pay	3,920.28	4,248.01	4,573.66	4,901.39	5,715.52	5,801.23	5,886.96	5,972.70	6,058.43	6,144.17		
Monthly + Holiday	4,151.58	4,498.64	4,843.51	5,190.57	6,052.73	6,143.50	6,234.29	6,325.09	6,415.88	6,506.67		
Annual Pay	47,043.36	50,976.12	54,883.92	58,816.68	68,586.18	69,614.74	70,643.56	71,672.38	72,701.20	73,730.02		
Annual + Holiday	49,818.92	53,993.71	58,122.07	62,286.86	72,632.76	73,722.01	74,811.53	75,901.05	76,990.57	78,080.09		
Lieutenant	Grade 4	Hourly Rate	28.9035	31.8179	32.8898	33.9858	35.6355	36.1701	36.7046	37.2393	37.7738	
Bi-Weekly Pay	2,312.28	2,545.43	2,631.18	2,718.86	2,850.84	2,893.61	2,936.37	2,979.14	3,021.90	3,064.66		
Holiday Pay	136.42	150.18	155.24	160.41	168.20	170.72	173.25	175.77	178.29	180.81		
Bi-Weekly + Holiday	2,448.70	2,695.61	2,786.42	2,879.27	3,019.04	3,064.33	3,109.62	3,154.91	3,200.19	3,245.47		
Monthly Pay	5,009.94	5,515.10	5,700.89	5,890.86	6,176.82	6,269.49	6,362.14	6,454.80	6,547.45	6,640.10		
Monthly + Holiday	5,305.93	5,840.49	6,037.24	6,238.42	6,541.25	6,639.39	6,737.50	6,835.64	6,933.75	7,031.86		
Annual Pay	60,119.28	66,181.18	68,410.68	70,690.36	74,121.84	75,233.66	76,345.62	77,457.64	78,569.40	79,681.16		
Annual + Holiday	63,666.32	70,085.87	72,446.91	74,661.09	78,495.03	79,672.66	80,850.01	82,027.64	83,204.99	84,382.35		
Captain	Grade 5	Hourly Rate	30.8786	34.0338	35.3224	36.5268	38.2489	38.8226	39.3964	39.9701	40.5438	
Bi-Weekly Pay	2,470.29	2,722.70	2,825.79	2,922.14	3,059.91	3,105.81	3,151.71	3,197.61	3,243.50	3,289.41		
Holiday Pay	145.75	160.64	166.72	172.41	180.53	183.24	185.95	188.66	191.37	194.08		
Bi-Weekly + Holiday	2,616.04	2,883.34	2,992.51	3,094.55	3,240.44	3,289.05	3,337.66	3,386.27	3,434.87	3,483.49		
Monthly Pay	5,352.30	5,899.18	6,122.55	6,331.30	6,629.81	6,729.26	6,828.71	6,928.16	7,027.58	7,127.06		
Monthly + HP	5,668.08	6,247.24	6,483.78	6,704.85	7,020.96	7,126.28	7,231.60	7,336.92	7,442.21	7,547.55		
Annual Pay	64,227.54	70,790.20	73,470.54	75,975.64	79,557.66	80,751.06	81,944.46	83,137.86	84,331.00	85,524.66		
Annual + Holiday	68,016.96	74,966.82	77,805.30	80,458.20	84,251.56	85,515.37	86,779.18	88,042.99	89,306.53	90,570.61		

City of Sheboygan
 Fire Department - "F" Pay Schedule - 2019
 2.0% Increase Effective 01/01/2020 (01/24/20 Payroll)
 All Grades Bi-Weekly Salary Based on 80 Hours
 Annual Salary Based on 26 Paydays
 Longevity = 1.5%, 3.0%, 4.5%, 6.0%, 7.5%

		BASE SALARY RATES					LONGEVITY RATES				
		HIRING RATE	AFTER 1 YEAR	AFTER 2 YEARS	AFTER 3 YEARS	AFTER 4 YEARS	After 5 Yrs Svc & 1 Yr @ MAXIMUM RATE 1.50%	After 10 Yrs Svc & 1 Yr @ MAXIMUM RATE 3.00%	After 15 Yrs Svc & 1 Yr @ MAXIMUM RATE 4.50%	After 20 Yrs Svc & 1 Yr @ MAXIMUM RATE 6.00%	After 25 Yrs Svc & 1 Yr @ MAXIMUM RATE 7.50%
		Step 1	Step 2	Step 3	Step 4	Step 5	Step 6	Step 7	Step 8	Step 9	Step 10
Firefighter/Paramedic	Grade 1	Hourly Rate				32.9825	33.4773	33.9719	34.4669	34.9614	35.4563
		Bi-Weekly Pay				2,638.60	2,678.18	2,717.75	2,757.35	2,796.91	2,836.50
		Holiday Pay				155.68	158.01	160.35	162.68	165.02	167.35
		Bi-Weekly + Holiday				2,794.28	2,836.19	2,878.10	2,920.03	2,961.93	3,003.85
		Monthly Pay				5,716.97	5,802.72	5,888.46	5,974.28	6,059.97	6,145.75
		Monthly + Holiday				6,054.27	6,145.08	6,235.88	6,326.74	6,417.51	6,508.35
		Annual Pay				69,603.60	69,632.68	70,661.50	71,691.10	72,719.66	73,749.00
	Annual + Holiday				72,651.21	73,741.01	74,830.53	75,920.67	77,010.12	78,100.19	
Equipment Operator	Grade 2	Hourly Rate	23.0694	24.9979	26.9143	28.8428	33.6336	34.1380	34.6425	35.1470	35.6515
		Bi-Weekly Pay	1,845.55	1,999.83	2,153.14	2,307.42	2,690.69	2,731.04	2,771.40	2,811.76	2,852.12
		Holiday Pay	108.89	117.89	127.04	136.14	158.75	161.13	163.51	165.89	168.28
		Bi-Weekly + Holiday	1,954.44	2,117.82	2,280.18	2,443.56	2,849.44	2,892.17	2,934.91	2,977.65	3,020.40
		Monthly Pay	3,998.69	4,332.97	4,665.14	4,999.41	5,829.83	5,917.25	6,004.70	6,092.15	6,179.59
		Monthly + Holiday	4,234.61	4,588.61	4,940.38	5,294.38	6,173.79	6,266.37	6,358.98	6,451.58	6,544.19
		Annual Pay	47,984.30	51,695.58	55,981.64	59,992.92	69,957.94	71,007.04	72,055.40	73,105.76	74,155.12
	Annual + Holiday	50,615.37	55,083.32	59,284.56	63,532.50	74,085.46	75,196.46	76,307.73	77,419.00	78,530.27	
Lieutenant	Grade 4	Hourly Rate	29.4816	32.4543	33.5475	34.6655	36.3483	36.8935	37.4388	37.9840	38.5293
		Bi-Weekly Pay	2,358.53	2,596.34	2,683.80	2,773.24	2,907.86	2,951.48	2,995.10	3,038.72	3,082.34
		Holiday Pay	139.15	153.18	158.34	163.62	171.56	174.14	176.71	179.28	181.86
		Bi-Weekly + Holiday	2,497.68	2,749.52	2,842.14	2,936.86	3,079.42	3,125.62	3,171.81	3,218.00	3,264.20
		Monthly Pay	5,110.15	5,625.40	5,814.90	6,008.69	6,300.36	6,394.87	6,489.38	6,583.89	6,678.40
		Monthly + Holiday	5,411.65	5,957.30	6,157.98	6,363.20	6,672.08	6,772.17	6,872.26	6,972.34	7,072.43
		Annual Pay	61,321.78	67,504.84	69,778.80	72,104.24	73,604.36	76,738.48	77,872.60	79,006.72	80,140.84
	Annual + Holiday	64,939.77	71,487.63	73,895.75	76,358.39	80,055.02	81,266.05	82,467.08	83,668.12	84,869.15	
Captain	Grade 5	Hourly Rate	31.4963	34.7144	36.0289	37.2573	39.0139	39.5991	40.1843	40.7695	41.3546
		Bi-Weekly Pay	2,519.70	2,777.15	2,882.31	2,980.58	3,121.11	3,167.93	3,214.74	3,261.56	3,308.37
		Holiday Pay	148.66	163.85	170.06	175.85	184.15	186.91	189.67	192.43	195.19
		Bi-Weekly + Holiday	2,668.36	2,941.00	3,052.37	3,156.43	3,305.26	3,354.84	3,404.41	3,453.99	3,503.56
		Monthly Pay	5,459.35	6,017.16	6,245.01	6,457.92	6,762.41	6,863.85	6,965.27	7,066.71	7,168.14
		Monthly + HP	5,781.45	6,372.17	6,613.46	6,838.94	7,161.39	7,269.82	7,376.22	7,483.65	7,591.05
		Annual Pay	65,512.20	72,265.90	74,940.06	77,495.08	81,148.88	82,366.18	83,583.24	84,800.56	86,017.62
	Annual + Holiday	69,377.42	76,466.05	79,361.52	82,067.29	85,938.64	87,225.78	88,514.65	89,803.79	91,092.66	

III

Res. No. - 18 - 19. By Alderpersons Rindfleisch and Bohren.
March 4, 2019.

A RESOLUTION authorizing the Purchasing Agent to issue a purchase order for the purchase of the 20 BCycle Bike Share Program and related software for use in the downtown and the waterfront areas.

WHEREAS, city staff have done extensive research of bike share options and have determined that the BCycle Bike Share Program would best meet the needs of the Sheboygan bike share program, since Milwaukee and Madison also use this system which would allow the user the option of also renting at those locations; and

WHEREAS, 20 bikes would be spread out between the lakefront, South Pier, and the downtown and would be available for public use; and

WHEREAS, the Parking Utility would operate and maintain the program for the city in partnership with the City Development Department; and

WHEREAS, the total cost of a 20 BCycle Bike Share Program is \$57,700 for bicycles and software, \$8,000 for an operation fee to be paid to BCycle for two years of operation, and \$2,500 in maintenance costs to be paid into a fund for the use of the Parking Utility.

Finance + Personnel

NOW, THEREFORE, BE IT RESOLVED: That the Purchasing Agent is authorized to issue a Purchase Order to BCYCLE, Waterloo, WI for \$65,700 and to the Parking Utility for \$2,500 and draw orders upon the following account numbers in payment of same:

Tourism-Advertising & Marketing	26054100-521400	\$30,200
TID16-Capital Project Fund- Improvements Other Than Buildings	42661100-631100	\$38,000

I HEREBY CERTIFY that the foregoing Resolution was duly passed by the Common Council of the City of Sheboygan, Wisconsin, on the _____ day of _____, 20____.

Dated _____ 20____. _____, City Clerk

Approved _____ 20____. _____, Mayor

III

Res. No. _____ - 18 - 19. By Alderpersons Rindfleisch and Bohren.
March 4, 2019.

A RESOLUTION authorizing the Senior Activity Center of Sheboygan to accept a donation of an automated external defibrillator (AED) to be placed at the Senior Activity Center.

WHEREAS, the Senior Activity Center of Sheboygan has received an offer for a donation of an AED from Aurora Health Care; and

WHEREAS, the Senior Activity of Sheboygan wishes to accept the donation.

NOW, THEREFORE, BE IT RESOLVED: That the Supervisor of the Senior Activity Center of Sheboygan is hereby authorized to accept the donation of the AED from Aurora Health Care and execute the letter agreement with Aurora Health Care, a copy of which is attached hereto and incorporated herein.

Finance & Personnel

I HEREBY CERTIFY that the foregoing Resolution was duly passed by the Common Council of the City of Sheboygan, Wisconsin, on the _____ day of _____, 20____.

Dated _____ 20____. _____, City Clerk

Approved _____ 20____. _____, Mayor



February 15, 2019

Wendy Schmitz, Supervisor
Senior Activity Center of Sheboygan
428 Wisconsin Ave, Sheboygan, WI 53081

Dear Wendy:

In 2015, Aurora Health Care launched the *When Minutes Matter* campaign, to not only improve cardiac arrest survival rates, but also to improve pre-hospital medicine in Ozaukee and Sheboygan Counties.

One initiative of the campaign was to remedy the lack of automated external defibrillators (AED) for public access and use in the communities we serve. In order to address this need, Aurora undertook an AED assessment in Ozaukee and Sheboygan Counties to determine where AED gaps exist within the community. Upon completion of the assessment, Aurora would distribute, through Aurora Health Care Foundation, AEDs to community partners for public access, allowing us to better the health in our communities and to meet community needs.

We are excited to share that your non-profit organization, Senior Activity Center of Sheboygan, has been identified to receive an AED from the Aurora Health Care Foundation.

With your acceptance of this gift, you agree to the following:

- You will place the device in a publicly accessible area within 4 weeks of receipt and will put up signs to appropriately direct the public to the device.
- An initial, one session, training opportunity will be provided by Aurora Health Care to the organization at a mutually agreeable date/time. Ongoing training will be your sole responsibility; Aurora will not provide any ongoing training.
- All maintenance and further costs (i.e. replacement batteries, replacement pads, etc) associated with the placement or use of the AED will be your sole responsibility.
- Maintenance or replacement parts can be obtained, at your cost, by contacting Scott Mullenberg, Account Executive at Allied 100, LLC at 715-356-0249 or scott@aeds.com.
- You will provide complete contact information to device manufacturer, Allied 100, LLC, so it may be registered to your organization, activate the warranty and receive the indemnification coverage from Allied 100, LLC as the owner/end user of the device.
- Should you ever close your doors or be unable to maintain the device properly, you will promptly, and at your cost, return the AED to Aurora Medical Center in Grafton's EMS team so it may be donated to another organization in need.



- You acknowledge and agree that no Aurora entity (including without limitation, Aurora Health Care Foundation) shall have any ongoing liability for this AED or for any use thereof by the community.

If you are able and willing to accept the AED and these terms, please return an executed copy of this agreement in the enclosed self-addressed, stamped envelope. In addition, if you have any questions, please contact us at 262-329-1910. We look forward to working with you.

Sincerely,

A handwritten signature in black ink, appearing to read "Steven Zils MD".

Steven Zils, MD
Out-of-hospital Medical Director
Aurora Health Care

A handwritten signature in black ink, appearing to read "Randy Varju".

Randy Varju
President
Aurora Health Care Foundation

Acknowledged and Agreed to

Senior Activity Center of Sheboygan

Wendy Schmitz
Supervisor

III

Res. No. _____ - 18 - 19. By Alderpersons Rindfleisch and Bohren.
March 4, 2019.

A RESOLUTION authorizing the appropriate City officials to execute the PILOT Agreement between the City of Sheboygan, Wasserman Redevelopment, LLC, and the Housing Authority of the City of Sheboygan, Wisconsin, with regard to the Housing Authority rental project located at 611 North Water Street.

RESOLVED: That the Mayor, City Clerk, and City Attorney are hereby authorized to execute the PILOT Agreement between the City of Sheboygan, Wasserman Redevelopment, LLC, and the Housing Authority of the City of Sheboygan, Wisconsin, in form substantially similar to the attached.

Finance Personnel

I HEREBY CERTIFY that the foregoing Resolution was duly passed by the Common Council of the City of Sheboygan, Wisconsin, on the _____ day of _____, 20____.

Dated _____ 20____. _____, City Clerk

Approved _____ 20____. _____, Mayor

PILOT AGREEMENT

This PILOT Agreement (“**Agreement**”) is entered into effective April 1, 2019, by and among the City of Sheboygan, Wisconsin (the “**City**”), Wasserman Redevelopment, LLC, a Wisconsin limited liability company (the “**Company**”) and The Housing Authority of the City of Sheboygan, Wisconsin a/k/a Sheboygan Housing Authority, a public body, corporate and politic, organized and existing under the laws of the State of Wisconsin (the “**Housing Authority**”).

RECITALS

WHEREAS, the Housing Authority has owned and operated a 105-unit HUD tenant protection voucher (“TPV”)s rental project located at 611 North Water Street, Sheboygan, Wisconsin 53081 as set forth in Exhibit A (referred to herein as the “**Property**”) and

WHEREAS, in order to raise debt and equity capital for the substantial rehabilitation and construction of the Property, the Housing Authority anticipates transferring federal income tax ownership of the Property to the Company in 2019 by leasing the Property consisting of a 105-unit TPV rental project more particularly described in the attached Exhibit A (the “**Project**”); and

WHEREAS, the Housing Authority is the sole managing member of the Company and the property manager of the Project, and, as such, exercises exclusive control and authority over the operation of the Project; and

WHEREAS, the Housing Authority has loaned substantial sums to the Company in connection with the acquisition and rehabilitation/construction of the Project, and has a right of first refusal to acquire the Project for a nominal sum following expiration of the fifteen (15)-year low-income housing tax period (the “**Compliance Period**”); and

WHEREAS, the Company is obligated to operate the Project as affordable housing in compliance with HUD and Internal Revenue Code restrictions and requirements, and the Housing Authority is solely responsible for ensuring that such restrictions and requirements are satisfied by the Company throughout the Compliance Period; and

WHEREAS, the Company will not generate material positive cash flow in excess of its fixed expenses, fees and debt obligations; and

WHEREAS, the parties have determined, based upon the foregoing RECITALS, that the Project constitutes property of the Housing Authority that is exempt from taxation under Section 70.11(18) of the Wisconsin Statutes and which may be subject to a payment in lieu of taxes (“**PILOT**”) imposed by the City, as provided in Section 66.1201(22) of the Wisconsin Statutes;

NOW, THEREFORE, acknowledging the receipt of sufficient consideration, the parties agree as follows:

1. Term of PILOT Agreement. The Company shall make a PILOT to the City with respect to the Project for each calendar year beginning in 2019 and ending in the final calendar year of the Project’s Compliance Period, now estimated to be calendar year 2035. As required by Section 66.1201(22) of the Wisconsin Statutes, such PILOT shall not exceed the amount that would be levied as the annual tax of the City upon the Project.

2. Computation of PILOT. The PILOT for each calendar year shall be ten percent (10%) of the difference between (a) one hundred percent (100%) of the tenant's portion of the collected rents for all of the residential rental units in the Project for such calendar year; and (b) one hundred percent (100%) of the electricity, water, sewer and fuel bills incurred by the Company with respect to the Project for such calendar year. The amounts under clauses (a) and (b) above shall be based upon the financial statements of the Company for the prior calendar year.

3. Payment of PILOT. The Company shall make the PILOT within the time periods applicable to properties that are not exempt from property taxation, as provided in Section 74.11 of the Wisconsin Statutes.

4. Obligation of Company and Housing Authority. The Housing Authority shall cause the Company to rehabilitate and operate the Project as affordable rental housing throughout the Compliance Period in accordance with the income, rent and other restrictions and limitations imposed by HUD and the Internal Revenue Code.

5. Obligations of City. The City shall furnish or cause to be furnished to the Company and/or Project tenants such services or facilities as are furnished to other property owners and residents of the City on the same basis as such City services are ordinarily provided. The City shall also, to the extent permitted by applicable law, apply or modify existing City codes and ordinances to permit the Housing Authority and the Company to operate the Project as described above throughout the Compliance Period.

6. Termination of Compliance Period. As noted in Paragraph 1 the final year of the Project's Compliance Period is estimated to be 2035. The Company and the Housing Authority shall, no earlier than 12 months and no later than six months before the beginning of the final calendar year, inform the City in writing that the following year is the last year of the Compliance Period. Upon such notice, the parties shall negotiate in good faith a new PILOT Agreement. If the parties cannot agree on a new PILOT Agreement, the Company, or its successor in interest, shall continue to pay a PILOT pursuant to the terms of this Agreement.

7. Miscellaneous. This Agreement cannot be unilaterally amended, modified or terminated by any party hereto. Each party hereby represents to and for the benefit of the other party that the person executing this Agreement on the signature page on behalf of such party has been duly authorized to execute this Agreement, and that this Agreement has been duly authorized and approved by such party. The benefits of this Agreement shall not be assigned by the Company or the Housing Authority without City's consent. This Agreement represents the entire agreement of the parties with respect to the subject matter hereof. This Agreement shall be governed by the laws of the State of Wisconsin. This Agreement may be signed by facsimile or in counterparts.

[SIGNATURE PAGE FOLLOWS]

IN WITNESS WHEREOF, the parties hereto duly execute this PILOT Agreement effective as of the date first set forth above.

CITY OF SHEBOYGAN

By:

Name: Mike Vandersteen
Its: Mayor

By:

Name: Meredith DeBuin
Its: City Clerk

By:

Name: Charles C. Adams
Its: City Attorney

THE HOUSING AUTHORITY OF THE CITY OF SHEBOYGAN, WISCONSIN A/K/A SHEBOYGAN HOUSING AUTHORITY

a public body, corporate and politic, organized and existing under the laws of the State of Wisconsin

By: Dean Bogenschuetz
Its: Chairperson

By: Joseph Rupnik
Its: Executive Director

WASSERMAN REDEVELOPMENT, LLC

a Wisconsin limited liability company

By: The Housing Authority of the City of Sheboygan, Wisconsin,
a public body, corporate and politic, organized and existing under the laws of the State of Wisconsin
Its: Managing Member

By: Dean Bogenschuetz
Its: Chairperson

By: Joseph Rupnik
Its: Executive Director

EXHIBIT A

PROJECT

105 apartment units located at 611 North Water Street, Sheboygan, Wisconsin 53081 more particularly described as:

Legal Description

Tax Parcel No. 59281107830

THE WEST 40 FEET OF LOT 4, ALL OF LOTS 5, 6, 7, 8, 9, AND 10, IN BLOCK 150, ORIGINAL PLAT OF THE CITY OF SHEBOYGAN, SHEBOYGAN COUNTY, WISCONSIN, AND MORE PARTICULARLY DESCRIBED AS FOLLOWS: BEGINNING AT AN IRON PIPE SET AT THE POINT OF INTERSECTION OF THE SOUTH LINE OF NEW YORK AVENUE WITH THE EAST LINE OF NORTH 10TH STREET, SAID POINT ALSO BEING THE NORTHWEST CORNER OF LOT 6 IN SAID BLOCK 150. THENCE, FROM SAID POINT OF BEGINNING, ON AN ASSUMED BEARING OF SOUTH 0°15'36" EAST, COINCIDENT WITH THE EAST LINE OF SAID NORTH 10TH ST., DISTANCE OF 168.01 FEET TO AN IRON PIPE SET AT THE POINT OF INTERSECTION OF THE EAST LINE OF SAID NORTH 10TH STREET WITH THE NORTHEASTERLY LINE OF NORTH WATER STREET; THENCE, SOUTH 35°53'57" EAST, COINCIDENT WITH THE NORTHEASTERLY LINE OF SAID NORTH WATER ST., AS DISTANCE OF 185.68 FEET TO A CHISELED CROSS MARKING, THE POINT OF INTERSECTION OF THE NORTHEASTERLY LINE OF SAID NORTH WATER ST. WITH THE NORTH LINE OF CENTER AVENUE; THENCE, SOUTH 89°45'02" EAST, COINCIDENT WITH THE NORTH LINE OF SAID CENTER AVENUE, A DISTANCE OF 132.00 FEET TO AN IRON PIPE SET AT THE POINT OF INTERSECTION OF THE NORTH LINE OF SAID CENTER AVENUE WITH THE EAST LINE OF LOT 10 IN SAID BLOCK 150, THENCE, NORTH 0°06'37" WEST, COINCIDENT WITH THE EAST LINE OF SAID LOT 10, A DISTANCE OF 150.77 FEET TO AN IRON PIPE SET AT THE POINT OF INTERSECTION OF THE EAST LINE OF SAID LOT 10 WITH THE SOUTH LINE OF AN EAST-WEST ALLEY; THENCE, NORTH 89°38'51" WEST, COINCIDENT WITH THE SOUTH LINE OF SAID ALLEY, A DISTANCE 80.20 FEET TO AN IRON PIPE SET AT THE POINT OF INTERSECTION OF THE SOUTH LINE OF SAID ALLEY WITH THE EAST LINE OF THE WEST 40.00 FEET OF LOT 4, SAID BLOCK, 150, EXTENDED; THENCE NORTH 0°08'37" WEST, COINCIDENT WITH THE EAST LINE OF THE WEST 40.00 FEET OF SAID LOT 4, AND ITS EXTENSION, A DISTANCE OF 18.00 FEET TO AN IRON PIPE SET AT THE POINT OF INTERSECTION OF THE EAST LINE OF THE WEST 40.00 FEET OF SAID LOT 4, WITH THE NORTH LINE OF SAID ALLEY; THENCE, CONTINUING NORTH 0°08'37" WEST, COINCIDENT WITH THE EAST LINE OF THE WEST 40.00 FEET OF SAID LOT 4, A DISTANCE 149.56 FEET TO AN IRON PIPE SET AT THE POINT OF INTERSECTION OF THE EAST LINE OF THE WEST 40.00 FEET OF SAID LOT 4, WITH THE SOUTH LINE OF SAID NEW YORK AVENUE; THENCE, NORTH 89°55'58" WEST, COINCIDENT WITH THE SOUTH LINE OF SAID NEW YORK AVENUE, A DISTANCE OF 160.73 FEET TO THE POINT OF BEGINNING. ALSO THE WEST 160 FEET OF THE ALLEY IN BLOCK 150 PER RESOLUTION RECORDED AUGUST 27, 1969 IN VOLUME 583 OF RECORDS, PAGE 86 AS DOCUMENT NO. 917147.

III

Res. No. _____ - 18 - 19. By Alderpersons Wolf and Donohue. March 4, 2019.

A RESOLUTION dissolving the Sustainable Sheboygan Task Force.

WHEREAS, the Sustainable Sheboygan Task Force was established by way of Subs. of Res. No. 22-08-09, as amended by Res. No. 54-08-09 and Res. No. 181-16-17; and

WHEREAS, the purpose of the Sustainable Sheboygan Task Force was to study and make recommendations to the Common Council regarding strategies to be adopted by the City for creating and maintaining a sustainable Sheboygan, focusing on such topics as recycling, green purchasing, energy conservation, waste management and sustainability measures, and raising community awareness on environmental stewardship, that would result in cost savings and reduced consumption of resources throughout the City of Sheboygan; and

WHEREAS, recommendations presented by the Sustainable Sheboygan Task Force have been implemented in the respective City departments and the Sustainable Sheboygan Task Force has fulfilled its purpose.

NOW, THEREFORE, BE IT RESOLVED: That the Sustainable Sheboygan Task Force is hereby eliminated and abolished and the associated authorizing resolutions (Subs. of Res. No. 22-08-09, as amended by Res. No. 54-08-09 and Res. No. 181-16-17) are hereby repealed.

BE IT FURTHER RESOLVED: That nothing in this resolution shall prevent the City Administrator from creating a city department green team to serve the City's future sustainability efforts.

BE IT FURTHER RESOLVED: That this Resolution shall be in effect from and after its passage and as of April 16, 2019.

JWS

I HEREBY CERTIFY that the foregoing Resolution was duly passed by the Common Council of the City of Sheboygan, Wisconsin, on the _____ day of _____, 20____.

Dated _____ 20____. _____, City Clerk

Approved _____ 20____. _____, Mayor

III

Res. No. _____ - 18 - 19. By Alderpersons Wolf and Donohue. March 4, 2019.

A RESOLUTION changing the starting time of the organizational meeting of the new council for council year 2019-20.

WHEREAS, the organizational meeting of the new council for council year 2019-20 is scheduled to be held on April 16, 2019 (the third Tuesday of April) pursuant to Subsection 2-112(a)(2) of the Municipal Code; and

WHEREAS, council meetings are currently being held in the Sheboygan County Board Chambers at the Sheboygan County Courthouse during the remodeling of City Hall; and

WHEREAS, the County Board of Supervisors has a meeting scheduled for April 16, 2019 at 6:00 p.m. in the County Board Chambers.

NOW, THEREFORE, BE IT RESOLVED: That the organizational meeting of the new council for council year 2019-20 scheduled to be held on April 16, 2019, shall be held at 7:30 p.m. or 20 minutes after the conclusion of the Sheboygan County Board meeting, whichever is later.

JHB

I HEREBY CERTIFY that the foregoing Resolution was duly passed by the Common Council of the City of Sheboygan, Wisconsin, on the _____ day of _____, 20____.

Dated _____ 20____. _____, City Clerk

Approved _____ 20____. _____, Mayor

III

Res. No. _____ - 18 - 19. By Alderpersons Wolf and Sorenson.
March 4, 2019.

A RESOLUTION authorizing the appropriate City officials to enter into a contract for the 2019 Sidewalk Program project.

WHEREAS, pursuant to Resolution No. 165-18-19, the Engineering Division of the Department of Public Works has advertised for bids for the 2019 Sidewalk Program project; and

WHEREAS, one bid was received in response to that advertisement; and

WHEREAS, the bid was from:

Klunck Masonry, LLC \$82,050.00; and

WHEREAS, the City Engineer has reviewed the bids and determined that the low bid, from Klunck Masonry, LLC, met all of the specifications.

NOW, THEREFORE, BE IT RESOLVED: That the appropriate City officials are hereby authorized to enter into the attached contract with Klunck Masonry, LLC for the 2019 Sidewalk Program Project in the amount of \$82,050.00 and are authorized to draw funds from the following account:

Sidewalk/Trail Improvements 40033140-631300 \$82,050.00

Public Works

I HEREBY CERTIFY that the foregoing Resolution was duly passed by the Common Council of the City of Sheboygan, Wisconsin, on the _____ day of _____, 20____.

Dated _____ 20 . _____, City Clerk

Approved _____ 20 . _____, Mayor

4.02 Contract Times: Dates

- A. The Work will be substantially completed on or before August 16, 2019 and completed and ready for final payment in accordance with Paragraph 15.06 of the General Conditions on or before the 14th day following substantial completion.

4.03 Liquidated Damages

- A. Contractor and Owner recognize that time is of the essence as stated in Paragraph 4.01 above and that Owner will suffer financial and other losses if the Work is not completed and Milestones not achieved within the times specified in Paragraph 4.02 above, plus any extensions thereof allowed in accordance with the Contract. The parties also recognize the delays, expense, and difficulties involved in proving in a legal or arbitration proceeding the actual loss suffered by Owner if the Work is not completed on time. Accordingly, instead of requiring any such proof, Owner and Contractor agree that as liquidated damages for delay (but not as a penalty):

1. Substantial Completion: Contractor shall pay Owner the amount identified in paragraph 19.01 of the Supplementary Conditions for each day that expires after the time (as duly adjusted pursuant to the Contract) specified in Paragraph 4.02.A above for Substantial Completion until the Work is substantially complete.
2. Completion of Remaining Work: After Substantial Completion, if Contractor shall neglect, refuse, or fail to complete the remaining Work within the Contract Times (as duly adjusted pursuant to the Contract) for completion and readiness for final payment, Contractor shall pay Owner the amount identified in paragraph 19.01 of the Supplementary Conditions for each day that expires after such time until the Work is completed and ready for final payment.
3. Liquidated damages for failing to timely attain Substantial Completion and final completion are not additive and will not be imposed concurrently.
4. Milestones: Contractor shall pay Owner the amount identified in paragraph 19.01 of the Supplementary Conditions for each day that expires after the time (as duly adjusted pursuant to the Contract) specified above for achievement of Milestone 1, until Milestone 1 is achieved.

4.04 Special Damages

- A. In addition to the amount provided for liquidated damages, Contractor shall reimburse Owner (1) for any fines or penalties imposed on Owner as a direct result of the Contractor's failure to attain Substantial Completion according to the Contract Times, and (2) for the actual costs reasonably incurred by Owner for engineering, construction observation, inspection, and administrative services needed after the time specified in Paragraph 4.02 for Substantial Completion (as duly adjusted pursuant to the Contract), until the Work is substantially complete.
- B. After Contractor achieves Substantial Completion, if Contractor shall neglect, refuse, or fail to complete the remaining Work within the Contract Times, Contractor shall reimburse Owner for the actual costs reasonably incurred by Owner for engineering, construction observation, inspection, and administrative services needed after the time specified in Paragraph 4.02 for Work to be completed and ready for final payment (as duly adjusted pursuant to the Contract), until the Work is completed and ready for final payment.

ARTICLE 5 – CONTRACT PRICE

5.01 Owner shall pay Contractor for completion of the Work in accordance with the Contract Documents the amounts that follow, subject to adjustment under the Contract:

- A. For all Work, at the prices stated in Contractor’s Bid, attached hereto as an exhibit.

ARTICLE 6 – PAYMENT PROCEDURES

6.01 *Submittal and Processing of Payments*

- A. Contractor shall submit Applications for Payment in accordance with Article 15 of the General Conditions. Applications for Payment will be processed by Engineer as provided in the General Conditions.

6.02 *Progress Payments; Retainage*

- A. Owner shall make progress payments on account of the Contract Price on the basis of Contractor’s Applications for Payment on or about the 1st day of each month during performance of the Work as provided in Paragraph 6.02.A.1 below, provided that such Applications for Payment have been submitted in a timely manner and otherwise meet the requirements of the Contract. All such payments will be measured by the Schedule of Values established as provided in the General Conditions (and in the case of Unit Price Work based on the number of units completed) or, in the event there is no Schedule of Values, as provided elsewhere in the Contract.

1. Prior to Substantial Completion, progress payments will be made in an amount equal to the percentage indicated below but, in each case, less the aggregate of payments previously made and less such amounts as Owner may withhold, including but not limited to liquidated damages, in accordance with the Contract

- a. 95 percent of Work completed (with the balance being retainage). If the Work has been 50 percent completed as determined by Engineer, and if the character and progress of the Work have been satisfactory to Owner and Engineer, then as long as the character and progress of the Work remain satisfactory to Owner and Engineer, there will be no additional retainage; and

- b. 0 percent of cost of materials and equipment not incorporated in the Work (with the balance being retainage).

- B. Upon Substantial Completion, Owner shall pay an amount sufficient to increase total payments to Contractor to 100 percent of the Work completed, less such amounts set off by Owner pursuant to Paragraph 15.01.E of the General Conditions, and less 200 percent of Engineer’s estimate of the value of Work to be completed or corrected as shown on the punch list of items to be completed or corrected prior to final payment.

6.03 *Final Payment*

- A. Upon final completion and acceptance of the Work in accordance with Paragraph 15.06 of the General Conditions, Owner shall pay the remainder of the Contract Price as recommended by Engineer as provided in said Paragraph 15.06.

ARTICLE 7 – INTEREST

7.01 All amounts not paid when due shall bear interest at the rate of 0 percent per annum.

ARTICLE 8 – CONTRACTOR’S REPRESENTATIONS

8.01 In order to induce Owner to enter into this Contract, Contractor makes the following representations:

- A. Contractor has examined and carefully studied the Contract Documents, and any data and reference items identified in the Contract Documents.
- B. Contractor has visited the Site, conducted a thorough, alert visual examination of the Site and adjacent areas, and become familiar with and is satisfied as to the general, local, and Site conditions that may affect cost, progress, and performance of the Work.
- C. Contractor is familiar with and is satisfied as to all Laws and Regulations that may affect cost, progress, and performance of the Work.
- D. Contractor has carefully studied all: (1) reports of explorations and tests of subsurface conditions at or adjacent to the Site and all drawings of physical conditions relating to existing surface or subsurface structures at the Site that have been identified in the Supplementary Conditions, especially with respect to Technical Data in such reports and drawings, and (2) reports and drawings relating to Hazardous Environmental Conditions, if any, at or adjacent to the Site that have been identified in the Supplementary Conditions, especially with respect to Technical Data in such reports and drawings.
- E. Contractor has considered the information known to Contractor itself; information commonly known to contractors doing business in the locality of the Site; information and observations obtained from visits to the Site; the Contract Documents; and the Site-related reports and drawings identified in the Contract Documents, with respect to the effect of such information, observations, and documents on (1) the cost, progress, and performance of the Work; (2) the means, methods, techniques, sequences, and procedures of construction to be employed by Contractor; and (3) Contractor’s safety precautions and programs.
- F. Based on the information and observations referred to in the preceding paragraph, Contractor agrees that no further examinations, investigations, explorations, tests, studies, or data are necessary for the performance of the Work at the Contract Price, within the Contract Times, and in accordance with the other terms and conditions of the Contract.
- G. Contractor is aware of the general nature of work to be performed by Owner and others at the Site that relates to the Work as indicated in the Contract Documents.
- H. Contractor has given Engineer written notice of all conflicts, errors, ambiguities, or discrepancies that Contractor has discovered in the Contract Documents, and the written resolution thereof by Engineer is acceptable to Contractor.
- I. The Contract Documents are generally sufficient to indicate and convey understanding of all terms and conditions for performance and furnishing of the Work.
- J. Contractor’s entry into this Contract constitutes an incontrovertible representation by Contractor that without exception all prices in the Agreement are premised upon performing and furnishing the Work required by the Contract Documents.

ARTICLE 9 – CONTRACT DOCUMENTS

9.01 *Contents*

- A. The Contract Documents consist of the following:
1. This Agreement (pages 00 52 00-1 to -[], inclusive).
 2. Performance bond (pages 00 61 13-1 to 00 61 13 - ____, inclusive).
 3. Payment bond (pages 00 61 14-1 to 00 61 14- ____, inclusive).
 4. General Conditions (EJCDC C-700, 2013 Edition) Supplementary Conditions, Specifications, and Drawings, not attached but incorporated by reference, as listed in the attached table of contents of the Project Manual.
 5. Addenda (not attached but incorporated by reference) (numbers 1 to -[], inclusive).
 6. Exhibits to this Agreement (enumerated as follows):
 - a. Contractor’s Bid (pages 1 to -[], inclusive).
 7. The following which may be delivered or issued on or after the Effective Date of the Contract and are not attached hereto:
 - a. Notice to Proceed,
 - b. Work Change Directives,
 - c. Change Orders,
 - d. Field Order,
 - e. Task Orders.
- B. The documents listed in Paragraph 9.01.A are attached to this Agreement (except as expressly noted otherwise above).
- C. There are no Contract Documents other than those listed above in this Article 9.
- D. The Contract Documents may only be amended, modified, or supplemented as provided in the General Conditions.

ARTICLE 10 – MISCELLANEOUS

10.01 *Terms*

- A. Terms used in this Agreement will have the meanings stated in the General Conditions and the Supplementary Conditions.

10.02 *Assignment of Contract*

- A. Unless expressly agreed to elsewhere in the Contract, no assignment by a party hereto of any rights under or interests in the Contract will be binding on another party hereto without the written consent of the party sought to be bound; and, specifically but without limitation, money that may become due and money that is due may not be assigned without such consent (except to the extent that the effect of this restriction may be limited by law), and unless specifically stated to the contrary in any written consent to an assignment, no assignment will release or discharge the assignor from any duty or responsibility under the Contract Documents.

10.03 Successors and Assigns

- A. Owner and Contractor each binds itself, its successors, assigns, and legal representatives to the other party hereto, its successors, assigns, and legal representatives in respect to all covenants, agreements, and obligations contained in the Contract Documents.

10.04 Severability

- A. Any provision or part of the Contract Documents held to be void or unenforceable under any Law or Regulation shall be deemed stricken, and all remaining provisions shall continue to be valid and binding upon Owner and Contractor, who agree that the Contract Documents shall be reformed to replace such stricken provision or part thereof with a valid and enforceable provision that comes as close as possible to expressing the intention of the stricken provision.

10.05 Contractor's Certifications

- A. Contractor certifies that it has not engaged in corrupt, fraudulent, collusive, or coercive practices in competing for or in executing the Contract. For the purposes of this Paragraph 10.05:
1. "corrupt practice" means the offering, giving, receiving, or soliciting of any thing of value likely to influence the action of a public official in the bidding process or in the Contract execution;
 2. "fraudulent practice" means an intentional misrepresentation of facts made (a) to influence the bidding process or the execution of the Contract to the detriment of Owner, (b) to establish Bid or Contract prices at artificial non-competitive levels, or (c) to deprive Owner of the benefits of free and open competition;
 3. "collusive practice" means a scheme or arrangement between two or more Bidders, with or without the knowledge of Owner, a purpose of which is to establish Bid prices at artificial, non-competitive levels; and
 4. "coercive practice" means harming or threatening to harm, directly or indirectly, persons or their property to influence their participation in the bidding process or affect the execution of the Contract.

10.06 Other Provisions

- A. Owner stipulates that if the General Conditions that are made a part of this Contract are based on EJCDC® C-700, Standard General Conditions for the Construction Contract, published by the Engineers Joint Contract Documents Committee®, and if Owner is the party that has furnished said General Conditions, then Owner has plainly shown all modifications to the standard wording of such published document to the Contractor, through a process such as highlighting or "track changes" (redline/strikeout), or in the Supplementary Conditions.

(Continued on next page)

IN WITNESS WHEREOF, Owner and Contractor have signed this Agreement.

This Agreement will be effective on _____ (which is the Effective Date of the Contract).

OWNER:

CONTRACTOR:

City of Sheboygan

By: _____
(signature)

Name,
Title: Darrell Hofland , City Administrator

Date: _____

By: _____
(signature)

Name,
Title: _____
(printed)

Date: _____

(If Contractor is a corporation, a partnership, or a joint venture, attach evidence of authority to sign.)

Address for giving notices:

City of Sheboygan - Engineering
2026 New Jersey Avenue
Sheboygan, WI 53081

Address for giving notices:

License No.: _____
(where applicable)

Signed by:

Approved as to form and Execution:

By: _____
(signature)

Name,
Title: Michael Vandersteen, Mayor

Date: _____

By: _____
(signature)

Name,
Title: Charles C. Adams, City Attorney

Date: _____

Countersigned by:

By: _____
(signature)

Name,
Title: Meredith DeBruin, City Clerk

Date: _____

2019 Sidewalk Program

SECTION	TITLE	PAGES
00 00 00	PROCUREMENT AND CONTRACTING REQUIREMENTS	
00 01 01	Cover	00 01 01-1
00 01 10	Table of Contents	00 01 10-1 to 00 01 10-1
00 11 13	Advertisements for Bids	00 11 13-1
00 21 13	Instructions for Bidders	00 21 13-1 to 00 21 13-10
00 41 43	Bid Form	00 41 43-1 to 00 41 43-5
00 41 44	Unit Price Worksheet	00 41 44-1
00 41 44.1	Quest Unit Price Worksheet	1 Pages
00 42 13	Bid Bond	00 42 13-1 to 00 42 13-2
00 45 13	Bidder's Proof of Responsibility	00 45 13-1 to 00 45-13-5
00 45 19	Non-Collusion Affidavit of Bidder	00 45 19-1
00 45 20	Non-Collusion Affidavit of Subcontractor	00 45 20-1
00 45 50	List of Subcontractors	00 45 50-1
00 52 00	Agreement	00 52 00-1 to 00 52 00-8
00 55 00	Notice to Proceed	00 55 00-1
00 61 13	Performance Bond	00 61 13-1 to 00 61 13-3
00 61 14	Payment Bond	00 61 14-1 to 00 61 14-3
00 62 11	Submittal Cover	00 62 11-1
00 62 76	Application for Payment	00 62 76-1 to 00 62 76-2
00 63 13	Request for Information	00 63 13-1
00 63 49	Work Change Directive	00 63 49-1
00 63 63	Change Order Form	00 63 63-1
00 65 16	Certificate of Substantial Completion	00 65 16-1
00 65 18	Certificate of Compliance	00 65 13-1
00 65 19	Consent of Surety to Final Payment	00 65 19-1
00 72 00	General Conditions	00 72 00 -1 to 00 72 00-72
00 73 00	Supplementary Conditions	00 73 00-1 to 00 73 00-13
01 00 00	GENERAL REQUIREMENTS	
01 11 00	Summary of Work	01 11 00-1 to 01 11 00-2
01 14 00	Work Restrictions	01 14 00-1 to 01 14 00-6
01 57 19	Temporary Environmental Controls	01 57 19-1 to 01 57 19-2
32 00 00	EXTERIOR IMPROVEMENT	
32 10 50	Concrete Sidewalk Program	32 10 50-1 to 32 10 50-9

2432-19 2019 Sidewalk Program (#6111160)

Owner: Sheboygan WI, City of

Solicitor: Sheboygan WI, City of

02/19/2019 10:00 AM CST

						Klunck Masonry LLC	
Line Item	Item Code	Item Description	UofM	Quantity	Unit Price	Extension	
	1 2019-1	Remove Concrete Sidewalk and Approaches	SF	9000	\$1.00	\$9,000.00	
	2 2019-2	Remove Concrete Aprons	SF	100	\$2.00	\$200.00	
	3 2019-3	Remove Curb & Gutter	LF	150	\$7.50	\$1,125.00	
	4 2019-4	Remove Integral Sidewalk/Curb	SF	200	\$6.00	\$1,200.00	
	5 2019-5	Excessive Cut	CY	50	\$25.00	\$1,250.00	
	6 2019-6	Excessive Fill/Gravel	Cy	50	\$18.00	\$900.00	
	7 2019-7	Concrete Sidewalk 4-inch	SF	9000	\$6.00	\$54,000.00	
	8 2019-8	Concrete Sidewalk 6-inch	SF	500	\$6.25	\$3,125.00	
	9 2019-9	Concrete Apron 7-inch	SF	100	\$6.00	\$600.00	
	10 2019-10	Concrete Curb and Gutter 30-inch	LF	150	\$24.00	\$3,600.00	
	11 2019-11	Concrete Curb 6-inch	LF	50	\$7.00	\$350.00	
	12 2019-12	Integral Sidewalk & Curb	SY	200	\$5.50	\$1,100.00	
	13 2019-13	Concrete Sawing	LF	250	\$6.00	\$1,500.00	
	14 2019-14	Grading For New Sidewalk	SF	500	\$2.00	\$1,000.00	
	15 2019-15	4-inch Topsoil, Seed & Fertilizer	SY	60	\$15.00	\$900.00	
	16 2019-16	Concrete Sidewalk 6-inch with Panel Finish	SF	200	\$6.00	\$1,200.00	
	17 2019-17	Curb Ramp Detectabel Warning Field	EA	10	\$100.00	\$1,000.00	
Total						\$82,050.00	

III

Res. No. _____ - 18 - 19. By Alderperson Wolf. March 4, 2019.

A RESOLUTION authorizing the Mayor to execute the amended 2019 General Contract between Sheboygan County Health & Human Services Department and Shoreline Metro regarding transportation for elderly and disabled individuals.

RESOLVED: That the Mayor is hereby authorized to execute said amended 2019 General Contract, a copy of which is attached hereto.

Transit

I HEREBY CERTIFY that the foregoing Resolution was duly passed by the Common Council of the City of Sheboygan, Wisconsin, on the _____ day of _____, 20____.

Dated _____ 20____. _____, City Clerk

Approved _____ 20____. _____, Mayor

2019 GENERAL CONTRACT

I. Parties and Contract Period

This contract is made and entered into for the period of January 1, 2019 through December 31, 2019 by and between Sheboygan County Health & Human Services Department, hereinafter referred to as County, and Shoreline Metro, hereinafter referred to as Provider.

Nothing in this contract shall create a partnership or joint venture between the County and the Provider. The Provider is at all times acting as an independent contractor and is in no sense an employee, agent or volunteer of the County.

In consideration of the mutual covenants herein, it is hereby agreed as follows.

County's employee responsible for administration of this contract will be Dale Deterding/Troy Krepsky, whose principal business address is 1011 North 8th Street, Sheboygan, Wisconsin 53081. Provider's employee responsible for administration of this contract will be Mr. Derek Muench, whose principal business address is 608 S. Commerce Street, Sheboygan, WI 53081. In the event that the Contract Administrator is unable to administer this Agreement, the County will contact the Provider and designate a new Contract Administrator.

II. Services to Be Provided

This contract is subject to terms and conditions set forth in the State/County Contract covering Administration of Income Maintenance Programs, Children and Families Programs, Social Services, and Community Programs, Community Youth, and Family Aids Programs. County agrees to purchase for and Provider agrees to provide to eligible clients the services as described in detail in this contract (see Section XIII).

III. Payment for Services

County and Provider agrees:

- A. The total amount to be paid to Provider by County for services provided in accordance with this Contract may be less, but shall not exceed the following contracted dollar amount. Actual total payment will be based upon the amount of service authorized by the County and the amount of service performed by the Provider. Unless otherwise stipulated, it is understood and agreed by all parties that the County assumes no obligation to purchase from the Provider any minimum amount of services as defined in the terms of this contract.

Payments for services covered by this contract shall be based on allowable costs with limited profit or reserve. Monthly payments will be made on a unit-times-unit price basis and in accordance with the "order of payment" requirements for the funding program, less client fees and other collections made by the Provider for services covered by this contract. Final settlement of the contract will be based on audit (see Section XII Audit Requirements).

The Provider agrees with the total cost for each service/program provided, and the rate (per hour, day, month, or year) and the number of clients and/or units of provided services. The County shall determine the type of services provided and the number of units of services provided for each client. The County will not reimburse the Provider for any unit of service not previously authorized by the County.

The Provider shall retain all documentation necessary to adequately demonstrate the named personnel providing the service, the credentials of named personnel providing the service, the date of service, time, duration, location, scope, quality and effectiveness of services rendered under the contract. The County reserves the right to not pay for units of services reported by the Provider that are not supported by documentation required under this contract.

<u>Service/Program</u>	<u>Rate</u>	<u># of Units</u>	<u>Units of Measure</u>	<u>Total Cost of Service</u>
Transportation	\$48.00	213	each	\$10,224.00
Transportation	\$48.00	12	each	\$576.00
Spec. Transp – Punch Card (bundle of 10 passes)	\$35.00	18	Each	\$630.00
Elderly/Disabled Transportation	\$326,476.00	1	year	\$326,476.00
			TOTAL:	\$337,906.00

When applicable, the Provider shall bill clients for a portion of the cost of care, in conformance with the requirements of Chapter DHS 1, Wisconsin Administrative Code and using the uniform schedule of fees and policies supplied by the County.

The Provider shall also bill any responsible third parties for the cost of care.

All amounts collected from clients and third parties shall be supported by the Provider's records and shall be reported to the County within 90 days.

Invoices can be sent to the HHS e-mail address: hhs.provider@SheboyganCounty.com.

- B. The county will make payments for costs that are consistent with the State Departments Allowable Cost Policy Manual and applicable Federal allowable cost policies. Program expenditures and descriptions of allowable costs are further described in 2 CFR Part 225 (formerly OMB Circular A-87) and Part 230 (formerly OMB Circular A-122) or the program policy manual. See Office of Management and Budget website for links to Code of Federal Regulations (CFR) sections: <https://www.whitehouse.gov/omb/information-for-agencies/circulars/>.

Wisconsin Statutes require that Purchase of Service rates be based on actual allowable costs. These costs have been identified in the Allowable Cost Policy Manual for each Department (online at <https://www.dhs.wisconsin.gov/business/allow-cost-manual.htm> or <https://dcf.wisconsin.gov/files/finance/fias/pdf/dcfallowablecostmanual.pdf> . The Statutes permit allowances for profit for For-Profit Providers and retention of excess revenue for non-profit Providers for specific cost categories. The amount allowable on an annual basis is determined by applying a percent equal to revenue received under the contract; all other profit/retention of earnings is unallowable. For Sheboygan County Health and Human Services, those limits have been set at 5 percent for both For-Profit Providers and Non-Profit Providers. Please see the Allowable Cost Policy Manual for more information on retention of excess revenues.

Provider shall return to County funds paid in excess of the allowable cost of services provided per 46.036(5) Wis. Stats. If the Provider fails to return funds paid in excess of the allowable costs of the services provided, County shall recover from Provider any money paid in excess of the allowable costs from subsequent payments made to the Provider.

- C. The County payment terms are net 60 days, and, while payment may be made in less than 60 days, there is no requirement and should be no expectation that this will occur.
- D. The Provider will submit monthly invoices that detail the type of service provided, the number of units (i.e. days, hours, miles, etc.) provided per client, date of service, the rate per unit, the authorization number, and any amounts collected from other resources. The invoice must be submitted by the 7th business day of each month for the prior month services and the December invoice must be submitted to the county for payment by January 10th of the next year.
- E. All billings for this contract period shall be received by the Purchaser no later than 90 days from date of service and all invoices for this contract year must be submitted no later than January 10th of the following year. Delinquent billings from this date will not be paid by the County.

IV. Billing and Collection Procedures

Invoices/Billing submitted to Sheboygan County Health & Human Services must be supported by client service information to include: name personnel providing the service, the credentials of named personnel providing the service, date of service, service provided, duration, unit of measure and units provided, rate, authorization number (issued by Sheboygan County), and client identification. Client services must be identified by date of service versus consolidated period billing. Invoices that do not contain an authorization number (per service/client) after January 1, 2018 will not be able to be processed for payment.

Fees collected on behalf of a client from any source will be treated as an adjustment to the costs and will be deducted from the amount paid under this contract.

V. Eligibility Standards for Recipients of Services

The Provider shall provide services only to those individuals who are eligible for services. Provider and County agree that the eligibility of individuals to receive the services to be purchased under this Agreement from Provider will be determined by County. An individual has a right to an administrative hearing concerning eligibility and the County shall inform individuals of this right. The Provider shall provide clients with information concerning their eligibility rights and how to appeal actions affecting those rights.

VI. Indemnity and Insurance

- A. Provider agrees that it will at all times during the existence of this Contract indemnify County against any and all loss, damages, and costs or expenses which County may sustain, incur, or be required to pay by reason of any eligible client's suffering, personal injury, death or property loss resulting from participating in or receiving the care and services to be furnished by the Provider under this Agreement; however, the provisions of this paragraph shall not apply to liabilities, losses, charges, costs, or expenses caused by County.
- B. Provider agrees that, in order to protect itself as well as the County under the indemnity provision set forth in the above paragraph, Provider will at all times during the terms of this contract keep in force a liability insurance policy issued by a company authorized to do business in the State of Wisconsin and licensed by the Office of the Commissioner of Insurance. The types of insurance coverage and minimum amounts shall be as follows (as applicable):

Comprehensive General Liability: minimum of \$1,000,000
Auto Liability (if applicable): minimum of \$1,000,000
Professional Liability (if applicable): minimum of \$1,000,000 per occurrence and \$3,000,000 for all occurrences in one (1) year;
Umbrella Liability (as necessary): minimum of \$1,000,000

Provider acknowledges that its indemnification liability to Purchaser is not limited by the limits of this insurance coverage.

Upon the execution of this Contract, Provider will furnish County with a "Certificate of Insurance" verifying the existence of such insurance. In the event of any action, suit, or proceedings against County upon any matter herein indemnified against, County shall, within five (5) working days, cause notice in writing thereof to be given to Provider by registered mail, addressed to its post office address. The Provider agrees to provide the County notice of cancellation or non-renewal of the policy within five (5) working days, by registered mail addressed to the County's post office address.

Provider agrees to provide the Purchaser with written verification of the existence of Worker's Compensation Insurance.

VII. Civil Rights Compliance/Assurances

All primary recipients and sub-recipients of Federal financial assistance must comply with all State and Federal Civil Rights laws and regulations. All Providers were required to submit a new Civil Rights Compliance (CRC) Letter of Assurance (LOA) by January 15, 2018 or within 15 working days from the date the grant, contract, or agreement was signed, if signed after January 1, 2018. All new Providers must submit LOA to be compliant for the CRC period of January 1, 2018 - December 31, 2021.

The provider agrees to meet state and federal Civil Rights Compliance (CRC) laws, requirements, rules, and regulations, as they pertain to the services covered by this contract. The website with instruction and templates necessary to complete both your CRC LOA and CRC plan to meet civil rights requirements is located at: <http://www.dhs.wisconsin.gov/civilrights/CRC/Requirements.htm> Additional resources and training information are available at: <https://dcf.wisconsin.gov/civilrights/plans>

All primary recipients and sub-recipients are obligated to meet the following requirements:

1. Provide civil rights and cultural awareness training to all agency employees.
2. Submit a Civil Rights Compliance Letter of Assurance (CRC LOA) to the appropriate state department. (Sub-recipients must submit the CRC LOA to the entity issuing the grant or contract.)
3. Providers that have more than fifty (50) employees and receive more than fifty thousand dollars (\$50,000) must develop and attach a Civil Rights Compliance Plan to this contract.
4. Providers that have more than fifty (50) employees and receive more than fifty thousand dollars (\$50,000) must develop and submit an Affirmative Action Plan to ensure equal access and equal opportunity in employment and service delivery to all applicants and participants. Additional information can be found at <http://vendornet.state.wi.us/vendornet/procman/prod3.pdf>

5. Provide oral language assistance and/or written translation to all limited English proficient (LEP) individuals requesting or applying for services to ensure equal access to programs, services and activities according to the LEP requirements and the recipient's or sub-recipient's LEP plan.

VIII. Contract Revisions and/or Terminations

- A. The County will monitor the Provider's performance and will use the results of this monitoring to evaluate the Provider's ability to provide adequate services to clients.
- B. Revisions of this contract must be agreed to by County and Provider by an addendum signed by the authorized representative of both parties.
- C. Provider shall notify County in writing delivered in person or by registered mail whenever it is unable to provide the required quality or quantity of services or as required by Section XIII L. of this contract. Upon such notification or if it is otherwise determined by the County that the Provider is not fulfilling the terms of the contract, the County may at its option immediately terminate the contract for cause, or seek a revision or suspension of its terms. If the County terminates the contract for cause, the Provider shall be liable to the County for any additional costs the County incurs for replacement services.
- D. This contract, or any part thereof, may be terminated immediately by either party for just cause, including, but not limited to, health and safety issues, fraud, criminal activity, violations of license or certification standards.
- E. This contract, or any part thereof, can be terminated by a 60-day written notice by either party without cause. Upon termination, the County's liability shall be limited to the costs incurred by the Provider up to the date of termination. If the County terminates the contract for reasons other than non-performance by the Provider, the County may compensate the Provider for its actual allowable costs in an amount determined by mutual agreement of both parties.

IX. Resolution of Disputes

The Provider may appeal decisions of the County in accordance with the terms and conditions of the contract and Chapter 68, Wis. Stats.

X. Records

- A. Provider shall maintain any records and financial statements as required by state and federal laws, rules and regulations.
- B. Provider will allow inspection of records and programs, insofar as it is permitted by state and federal laws, by representatives of the County, the Department of Health Services, Children and Families, Workforce Development or Department of Corrections and their authorized agents, and Federal agencies, in order to confirm Provider's compliance with the specifications of this contract.
- C. The use or disclosure by any party of any information concerning eligible clients who receive services from Provider for any purpose not connected with the administration of Provider's or County's responsibilities under this contract is prohibited except with the informed, written consent of the eligible client or the client's legal guardian.

- D. Under s.19.36 (3) Wis. Stats., all records of the Provider that are produced or collected under this contract are subject to disclosure pursuant to a public records request.

The Provider shall maintain such records (in either written or electronic form) as required by State and Federal Law and as required by program policies. The Provider shall retain records in a secure environment for no less than the retention period specified in law or policy, or as otherwise stated within the Scope of Service. Records for periods which are under audit or subject to dispute or litigation must be retained until the audit/dispute/litigation, and any associated appeal periods, have ended.

Upon the County's request, at the expiration of the contract, the Provider will transfer at no cost to the County records regarding individual recipients who received services from Provider under this agreement. The transfer of records includes transfer of any record, regardless of media, if that is the only method which records were maintained.

The Provider shall make all records and any written and/or electronic case information available to the County or the State of Wisconsin upon request, and will allow inspection of records and programs, insofar as is permitted under State and Federal law.

XI. Reporting

Provider shall comply with the reporting requirements of the County and applicable State Departments. Client services shall be reported by service date and service provided. All reports shall be in writing and, when applicable, in the format specified by the County. All reports shall be supported by the Provider's records.

XII. Provider Audit Responsibilities

Provider agrees to adhere to the following audit requirements:

- A. Cooperate with the County in establishing costs for reimbursement purposes per s.46.036(4)(b), Wis. Stats.
- B. Adhere to the following audit requirements:

Wis. Stat. DHS 46.036(4)(c) and DCF 49.34(4)(c), requires Providers to provide an annual audit in accordance with the requirements of 2 CFR Part 200-Uniform Administrative Requirements, Cost Principles, and Audit Requirements for Federal Awards to County if the total amount of annual funding provided by the county through this and other contracts is \$100,000 or more, unless the audit requirement is waived by the State of Wisconsin or the County. The audit shall also be in accordance with the applicable State Department Audit Guide. Providers receiving less than \$100,000 are required to provide annual Financial Statements (Profit and Loss, Balance Sheet and Cash Flow Statements) to the County in place of Audit. This includes providing supplemental schedules, below in sub section E.

Sites of reference:

CFR Part 200 is available online at www.ecfr.gov

State Single Audit Guidelines is available at

<https://doa.wi.gov/Pages/StateFinances/State-Single-Audit-Guidelines.aspx>

Provider Agency Audit Guide is available at

<https://dcf.wisconsin.gov/files/finance/fias/pdf/paag.pdf>

Provider is to submit a copy of the certified financial and compliance audit to the County within 180 days of the end of the Provider's fiscal year. If available, digital copies are preferred. (If Provider has approved IRS extensions on their corporate tax returns, this extension will also apply to the submissions requirement deadline stated above.) The standards for the provider agency annual audits vary by type of agency as shown below.

1. **Non-Profit Providers:** Audits must be completed pursuant to the applicable State Department's Audit Guide and, if the vendor expends more than \$750,000 annually in federal financial assistance, to 2 CFR 200. See OMB 2 CFR 200 §200.330 for the distinction between contractors and sub recipients. The audit documentation must include a Reserve Supplemental Schedule in the audit report, and this schedule shall also be by contract or service category.
 2. **For Profit Providers:** Audits must be completed pursuant to the purchase contract language, the applicable State Department's Audit Guide, and the current applicable State Department's Allowable Costs Policy Manual. The audit documentation must include reports showing total allowable costs and the calculations of the allowable profit by contract or by service category.
- C. Source of funding information shall be provided at time of audit confirmation.
- D. The Provider shall submit to the County a reporting package that includes: (a) all audit schedules and reports required for the type of audit applicable to the agency; (b) a summary schedule of prior year findings and the status of addressing these findings; (c) a Management Letter (or similar document conveying auditor's comments issued as a result of the audit); (d) management responses/corrective action plan for each audit issue identified in the audit; and (e) a copy of the financial auditor's most recent peer review report.
- E. In addition to the supplemental schedules listed under D., the reporting package shall include a supplemental schedule showing revenue and expenses for this Contract.
- F. The Provider shall send the required reporting package to the County within 180 days of the end of the Provider's fiscal year.
- G. When contracting with an audit firm, the Provider shall authorize its auditor to provide access to work papers, reports, and other materials generated during the audit to the appropriate representatives of the County. Such access shall include the right to obtain copies of the work papers and computer disks, or other electronic media, upon which audit work is documented.
- H. Failure to comply with the requirements of this section: If the Provider fails to have an appropriate audit performed or fails to provide a complete audit reporting package to the County within the specified time frames, the County may:
1. Conduct an audit or arrange for an independent audit of the Provider and charge the cost of completing the audit to the Provider;
 2. Charge the Provider for all loss of Federal or State aid and for penalties assessed to the County because the Provider did not submit a complete audit report within the required time frame;
 3. Disallow the cost of audits that do not meet these standards; and/or

4. Withhold payment, cancel the Contract, or take other actions deemed by the County to be necessary to protect the County's interests;
 5. Require modified monitoring and/or reporting provisions;
 6. Assess financial sanctions or penalties;
 7. Discontinue contracting with the Provider;
 8. Take other action that Purchaser determines is necessary to protect Federal or State pass through funding
- I. Providers wishing to request an audit waiver must do so at the time of contracting.

XIII. Provider Responsibilities and Performance of Service

The County retains sole authority to determine whether the Provider's performance under this contract is adequate. The Provider agrees to the following:

- A. The Provider shall allow the County's staff and authorized agents to visit the Provider's facility or work site at any time for the purposes of ensuring that services are being provided as specified in the service plan and the contract.
- B. Upon request by the County or its designee, the Provider shall make available to the County all documentation necessary to adequately assess Provider performance.
- C. The Provider will cooperate with the County in its efforts to implement any quality improvement and quality assurance program.
- D. The Provider shall develop and implement a process for assessing client satisfaction with services provided. The Provider shall report in a timely manner the results of its client satisfaction assessment effort to the County. The County reserves the right to review and approve the Provider's client satisfaction assessment process and to require Provider to submit a corrective action plan to address concerns identified in the review.
- E. The Provider shall cooperate with the County in implementing any County program for assessing client satisfaction with services. The County reserves the right to require the Provider to submit a corrective action plan to address concerns identified in review.
- F. The Provider shall have a formal written grievance procedure that is approved by the licensing or certification authority, if applicable, and by the County. The Provider shall, prior to or at the time of admission to the Program, provide oral and written notification to each client of his or her rights and the grievance procedure. The Provider shall post the client rights and the grievance procedure.

At least once a year, or more frequently when requested by the County, the Provider shall give the County a written summary report of all grievances that have been filed with the Program by clients or their guardians since the period covered by the previous summary report and of the resolution of each grievance. The Provider shall deliver the annual summary report to the County in person or via registered mail within 30 days of the end of the contract period.

Additional summary reports requested by the County shall be due within 10 days of the County's request for the reports and shall be delivered to the County in person or via registered mail.

- G. The Purchaser and the Provider agree that the protection of the clients served under this contract is paramount to the intent of this contract. In order to protect the clients served, the Provider shall comply with the provisions of DHS 12, Wis. Admin. Code (online at http://docs.legis.wi.gov/code/admin_code/dhs/001/12). The Provider shall conduct caregiver background checks at its own expense of all employees assigned to do work for the County under this contract as well as any other persons under control of the Provider having direct contact with the clients of the County. The Provider shall retain in its Personnel Files all pertinent information, to include a Background Information Disclosure Form and/or search results from the Department of Justice, the Department of Health Services, Department of Children and Families, and the Department of Safety and Professional Services, as well as out of state records, tribal court proceedings and military records, if applicable.

After the initial background check, the Provider must conduct a new caregiver background search every four (4) years, or more frequently, as required for some provider types, or at any time within that period when the Provider has reason to believe a new check should be obtained.

The Provider shall maintain the results of background checks on its own premises for at least the duration of the contract. The County may audit the Provider's personnel files to assure compliance with the State of Wisconsin Caregiver Background Check Law.

The Provider shall not assign any individual to conduct work under this contract who does not meet the requirement of this law.

Prior to the commencement of any services under this contract, the County may request a background or criminal history investigation of any of the Provider's employees, contracted personnel, and subcontracted employees, who will be providing services to the County under the contract. If any of the stated personnel providing services to the County under this contract is not acceptable to the County in its sole opinion as a result of the background or criminal history investigation, the County may either request immediate replacement of the person in question, or immediately terminate this Contract and any related service agreement. The Provider shall notify the County in writing via certified mail within one business day if an employee has an allegation filed regarding a barring offense or has been charged with or convicted of any crime specified in DHS 12.07(2).

With regards to DHS 13.05, the provider has a responsibility to protect clients upon learning of an incident of alleged misconduct; the provider shall take whatever steps are necessary to ensure that clients are protected from subsequent episodes of misconduct while a determination on the matter is pending. In addition, the provider has a responsibility to report allegations of caregiver misconduct immediately, by telephone or personally, to the county department of human services the facts and circumstances contributing to a suspicion that abuse or neglect has occurred or to a belief that it will occur. In addition, the entity shall notify the department in writing or by phone within 7 calendar days that the report has been made.

- H. The Provider shall not use or disclose any information concerning eligible clients who receive services from Provider for any purpose not connected with the administration of Provider's or County's responsibilities under this contract, except with the informed, written consent of the

eligible client or the client's legal guardian. Except for documents identifying specific clients, the contract and related documents are not confidential.

- I. The Provider shall ensure the establishment of safeguards to prevent employees, consultants, or members of the board from using their positions for purposes that are, or give the appearance of being, motivated by a desire for private gain for themselves or others, such as those with whom they have family, business or other ties.
- J. The Provider shall meet state and federal service standards and applicable state training, licensure and certification requirements as expressed by state and federal rules and regulations applicable to the services covered by this contract. The Provider shall attach copies of its license or certification document and the most recent training, licensing or certification report concerning the Provider to this contract when returning the signed contract to the County. During the contract period, the Provider shall also send the County copies of any licensing inspection reports within 5 days of receipt of such reports.
- K. The Provider shall ensure that staff providing services are properly supervised and trained and that they meet all of the applicable licensing and certification requirements.
- L. The Provider shall submit any performance and other program reports required by the County.
- M. All property, equipment, software, or services used by multiple programs or for multiple purposes subject to cost allocation procedures. The Provider will appropriately adjust claimed expenditures under a cost-sharing allocation plan if automation equipment, software or other services, including staff services, are used for any purpose other than child support program administration.

The provider shall submit a copy of their cost allocation plan to the County upon request. Costs must be allocated in a manner consistent with these plans. The plans must be in accordance with the requirements of applicable Federal cost policies.

XIV. Debarment and Suspension

The Provider certifies through signing this contract that neither the Provider nor any of its principals are debarred, suspended, proposed for debarment, declared ineligible, or voluntarily excluded from participating in federal assistance programs by any federal department or agency. In addition, the Provider shall notify the County within five business days in writing and sent by registered mail if the Provider or its principals receive a designation from the federal government that they are debarred, suspended, proposed for debarment or declared ineligible by a federal agency or whenever the Provider determines it is unable to provide the quality or quantity of services required under this contract. The County may consider suspension or debarment to be a cause for revising or terminating the contract.

XV. Health Insurance Portability and Accountability Act of 1996 (HIPAA) Applicability

The Provider agrees to comply with the federal regulations implementing the Health Insurance Portability and Accountability Act of 1996 (HIPAA) to the extent those regulations apply to the services the Provider provides or purchases with funds provided under this contract.

In addition, certain functions included in this agreement are covered by HIPAA rules. As such the County must comply with all provisions of the law and has determined that Provider is a "Business

Associate” within the context of the law. As a result, the Purchaser requires Provider to sign and return with this contract the Business Associate Agreement, which will be included and made part of this agreement.

XVI. Privacy and Confidential Information

- A. All case information, paper records, written information, and any electronic data shall remain confidential, as required by law and applicable to this policy. All records pertaining to services provided under this contract are the sole property of the County. Provider shall comply with all State and Federal confidentiality laws concerning information in both the records it maintains and in any other confidential records the Provider accesses to provide services under this contract.
- B. Except as otherwise authorized by law, the Provider may not disclose confidential information for any purpose other than the purposes associated with the administration of services under this contract. “Confidential Information” means all tangible and intangible information and materials accessed or disclosed in connection with this Agreement, in any form or medium (and without regard to whether the information is owned by the State of Wisconsin, the County Agency, or by a third party), that satisfy at least one of the following criteria:
1. Personally Identifiable Information;
 2. Individually Identifiable Health Information;
 3. Non-Public information related to the County’s employees, customers, technology (including data bases, data processing and communications networking systems), schematics, specifications, and all information or materials derived there from or based thereon; or
 4. Information designated as confidential in writing by the County.
- C. “Individually Identifiable Health Information” means information that relates to the past, present, or future physical or mental health or condition of the individual, or that relates to the provision of health care in the past, present or future, and that is combined with or linked to any information that identifies the individual or with respect to which there is a reasonable basis to believe the information can be used to identify the individual.
- D. “Personally Identifiable Information” means an individual’s last name and the individuals first name or first initial, in combination with and linked to any of the following elements, if the element is not publicly available information and is not encrypted, redacted, or altered in any manner that renders the element unreadable:
1. The individual’s Social Security Number;
 2. The individual’s driver’s license number or state identification number;
 3. The number of the individual’s financial account, including a credit or debit account number, or any security code, access code, or password that would permit access to the individual’s financial account;
 4. The individual’s DNA profile; or
 5. The individual unique biometric data, including fingerprint, voice print, retina or iris image, or any other unique physical representation, and any other information protected by State or Federal law.
- E. “Indemnification” means in the event of a breach of this Section by the Provider, the Provider shall indemnify and hold harmless the County and any of its officers, employees, or agents

from any claims arising from the acts or omissions of the Provider and its employees and agents, in violation of this Section, including but not limited to costs of monitoring the credit of all persons whose Confidential Information was disclosed, disallowances or penalties from Federal oversight agencies, and any court costs, expenses, and reasonable attorney fees, incurred by the County in the enforcement of this Section.

- F. "Equitable relief" means the provider acknowledges and agrees that the unauthorized use, disclosure, or loss of Confidential Information may cause immediate and irreparable injury to the individuals whose information is disclosed and to both the State of Wisconsin and the County, which injury will not be compensable by money damages and for which there is not an adequate remedy available at law. Accordingly, the parties specifically agree that the State and/or County, on their own behalf or on the behalf of the affected individuals, may seek injunctive or other equitable relief to prevent or curtail any such breach, threatened or actual, without posting security and without prejudice to such other rights as may be available under this Agreement or under applicable law.
- G. Confidential Information does not include information which is required to be disclosed by operation of law.

XVII. Conditions of the Parties' Obligations

- A. This contract is contingent upon authorization of Wisconsin and United States laws and any material amendment or repeal of the same affecting relevant funding or authority of any applicable State Department shall serve to terminate this Agreement, except as further agreed to by the parties hereto.
- B. Nothing contained in this contract shall be construed to supersede the lawful powers or duties of either party.
- C. It is understood and agreed that the entire contract between the parties is contained herein, except for those matters incorporated herein by reference, and that this Agreement supersedes all oral agreements and negotiations between the parties relating to the subject matter thereof.
- D. County shall be notified in writing of all complaints filed in writing against the Provider. County shall inform the Provider in writing with their understanding of the resolution of the complaint.
- E. The Provider certifies that, for the duration of this contract, no Sheboygan County Health and Human Services staff will be utilized to staff Provider's services. Violation will result in the contract being null and void. The Provider will provide a list of staff upon request.

XVIII. Legal Status

Provider warrants that it has complied with all necessary requirements to do business in the State of Wisconsin, that the persons executing this contract on its behalf are authorized to do so. Provider shall notify the County immediately, in writing, of any change in its legal status.

XIX. Addendums

The following checked addendums are incorporated through reference as inclusive documents to the body of the contract:

- | | |
|--|---|
| <input type="checkbox"/> CBRF Adult Family Home | <input type="checkbox"/> SHC Respite |
| <input type="checkbox"/> CCS Provider Responsibilities | <input type="checkbox"/> Sheboygan Senior Dining Program Requirements |
| <input type="checkbox"/> CRS Provider Responsibilities | <input type="checkbox"/> Supported Employment Addendum |
| <input type="checkbox"/> Daily Living Skills | <input type="checkbox"/> Treatment Foster Home Addendum |
| <input type="checkbox"/> Guardianship Addendum | Other: _____ |
| <input type="checkbox"/> RCC Addendum | |
| <input checked="" type="checkbox"/> Safety Assurances | |
| <input type="checkbox"/> Representative Payee Addendum | |

XX. Signatures

This contract is agreed upon and approved by the authorized representatives of Sheboygan County and Shoreline Metro (Provider) as indicated below. This Contract becomes null and void if the time between the County's authorized representative signature and the Provider's authorized representative signature on this Contract exceeds sixty (60) days.

For County:

Matthew Strittmater, Director
County's Authorized Representative
Sheboygan County Health & Human Services

Date

For Provider:

Provider's Authorized Representative

Date

Title:

Federal ID #: _____

VIII

R. C. No. _____ - 18 - 19. By PUBLIC WORKS COMMITTEE. March 4, 2019.

Your Committee to whom was referred Res. No. 176-18-19 by Alderpersons Wolf and Sorenson authorizing a transfer of appropriations in the 2019 Budget (traffic signal upgrade); recommends approving the Resolution.

Reg.

Committee

I HEREBY CERTIFY that the foregoing Committee Report was duly accepted and adopted by the Common Council of the City of Sheboygan, Wisconsin, on the _____ day of _____, 20____.

Dated _____ 20____. _____, City Clerk

Approved _____ 20____. _____, Mayor

III

4.2

Res. No. 176-18-19. By Alderpersons Wolf and Sorenson.
February 18, 2019.

A RESOLUTION to authorize a transfer of appropriations in the 2019 Budget.

RESOLVED: That the Finance Director be and is hereby authorized and directed to make the following transfer of appropriations in the 2019 Budget for purposes of:

Establishing appropriations for the traffic signal upgrade associated with the intersection of South Business Drive and Union Avenue:

<u>FROM</u>	<u>TO</u>	<u>AMOUNT</u>
Other Equipment-Traffic 47733250-649100	Other Equipment-Traffic 47833250-649100	\$50,000.00

*Public Works
approve*

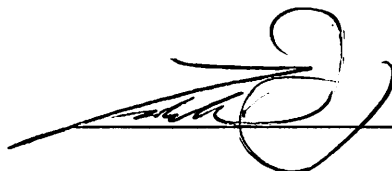

I HEREBY CERTIFY that the foregoing Resolution was duly passed by the Common Council of the City of Sheboygan, Wisconsin, on the _____ day of _____, 20____.

Dated _____ 20____. _____, City Clerk

Approved _____ 20____. _____, Mayor

VIII

R. C. No. _____ - 18 - 19. By FINANCE AND PERSONNEL COMMITTEE.
March 4, 2019.

Your Committee to whom was referred DIRECT REFERRAL Res. No. 177-18-19 by Alderpersons Rindfleisch and Bohren authorizing entering into a letter agreement with Graef-USA, Inc. for professional planning services; recommends approving the Resolution with updated contracts.

Reg.

Committee

I HEREBY CERTIFY that the foregoing Committee Report was duly accepted and adopted by the Common Council of the City of Sheboygan, Wisconsin, on the _____ day of _____, 20____.

Dated _____ 20____, _____, City Clerk

Approved _____ 20____, _____, Mayor

III

DIRECT REFERRAL TO FINANCE AND PERSONNEL COMMITTEE

Res. No. 177 - 18 - 19. By Alderpersons Rindfleisch and Bohren.
February 25, 2019.

A RESOLUTION authorizing entering into a letter agreement with Graef-USA, Inc. for professional planning services.

RESOLVED: That the Common Council hereby approves and authorizes the Director of Planning and Development to enter into a letter agreement with Graef-USA, Inc. for professional planning services, a copy of which is attached hereto.

BE IT FURTHER RESOLVED: That the Director of Planning and Development is hereby authorized to add additional services to be performed by Graef-USA, Inc., as long as the "not to exceed" amount is not exceeded.

Finance & Personnel approve w/ updated contracts

I HEREBY CERTIFY that the foregoing Resolution was duly passed by the Common Council of the City of Sheboygan, Wisconsin, on the _____ day of _____, 20____.

Dated _____ 20____. _____, City Clerk

Approved _____ 20____. _____, Mayor



collaborāte / formulāte / innovāte

February 25, 2019

Chad Pelishek
City of Sheboygan
828 Center Ave.
Sheboygan, WI 53081

SUBJECT: Planning Services

Dear Mr. Pelishek:

Per your request, Graef-USA Inc. (GRAEF) is pleased to provide this proposal for services to the City of Sheboygan (Client). An executed copy of this proposal will become our Agreement.

This proposal is for professional planning services to the City of Sheboygan (Project). This proposal is subject to GRAEF's Terms and Conditions, a copy of which is attached and incorporated by reference. For each effort commissioned within this Agreement, the City shall request of GRAEF and authorize a scope, schedule, and fee. For this Project, GRAEF proposes to provide the following Basic Services:

- Carry out the work efforts requested by the City Director of Planning & Development
- Prepare scopes, schedules, and fees for specific projects as requested by the City

For this Project, it is our understanding Client will provide the following services, items and/or information:

- Coordinate with the City Council on specific project proposals
- Carry out approvals for the scope, schedule, and fee of each specific project prior to authorizing work
- Provide logistics and secure space for meetings in the community

For all Basic Services, Client agrees to compensate GRAEF on a lump sum or time and materials basis per the attached hourly rates as listed in each work order, plus reimbursable expenses. Hourly rates and reimbursable expenses will be adjusted annually in April. Reimbursable expenses include express mail and delivery charges, existing mapping purchase costs, plan reproduction and mileage.



collaborāte / formulāte / innovāte

The total not-to-exceed amount for this proposal is \$65,000. Work Order 01 (Harbor Centre District Master Plan) has a not-to-exceed amount for the Basic Services of \$33,734.00. Work Order 02 (River South Neighborhood Plan) has a not-to-exceed amount for the Basic Services of \$29,937.00. The difference between the total not-to-exceed amount for this proposal and the amounts actually expended on the Basic Services on Work Orders 01 and 02 may be used for additional services related to Work Orders 01 and 02 or one or more additional Work Orders.

To accept this proposal, please sign and date this agreement and return a copy to us. Upon receipt of an executed copy, GRAEF will commence work on the Project. Graef-USA Inc. looks forward to providing services to the City of Sheboygan.

Sincerely,

Graef-USA Inc.

Accepted by: City of Sheboygan

Brent T. Pitcher, P.E., LEED AP
Vice President

(Signature)

Lawrence Witzling
Principal

(Name Printed)

(Title)

Date: _____



Graef-USA Inc.'s TERMS AND CONDITIONS

These Terms and Conditions are material terms of the Professional Services Agreement proposed on February 25, 2019 (Agreement) by and between Graef-USA Inc. (GRAEF) and City of Sheboygan (Client):

Standard of Care: GRAEF shall exercise ordinary professional care in performing all services under this Agreement, without warranty or guarantee, expressed or implied.

Client Responsibilities: Client shall at all times procure and maintain financing adequate to timely pay for all costs of the PROJECT as incurred; shall timely furnish and provide those services, items and/or information defined in Agreement, as amended, and shall reasonably communicate with and reasonably cooperate with GRAEF in its performance of this Agreement. GRAEF shall be entitled to rely on the accuracy and completeness of any services, items and/or information furnished by Client. These terms are of the essence. Client shall indemnify, defend and hold GRAEF, its present or former officers, employees and subconsultant(s), fully harmless from any liability or loss, cost or expense (including attorney's fees and other claims expenses) in any way arising from or in connection with errors, omissions or deficiencies in the services, items and/or information Client is obliged to furnish in respect of this Agreement.

Limitation of Liability: Client and GRAEF agree that GRAEF's liability for any direct, indirect, incidental or consequential economic losses or damages arising under or in connection with this agreement (including any attorney's fees or claims expenses) shall be limited to the sum of one million dollars (\$1,000,000.00).

Additional Services: Client may request or it may become necessary for GRAEF or its subconsultant(s) to perform Additional Services in respect of this Agreement. Client shall pay for such Additional Services above and beyond charges for Basic Services set forth in this Agreement. GRAEF will notify Client in advance of GRAEF's intention to render Additional Services. Client shall have fifteen (15) days to accept or reject any Additional Services proposed by GRAEF. In the event that Client does not respond within fifteen (15) days, Client shall be deemed to have rejected the Additional Services. Client's acceptance of Additional Services and agreement to pay for such Additional Service in accordance with the Invoicing & Payment terms of this Agreement.

Collection Costs: Client shall pay all collection costs GRAEF incurs in order to collect amounts due from Client under this Agreement. Collection costs shall include, without limitation, reasonable attorney's fees and expenses, collection agency fees and expenses, court fees, collection bonds and reasonable GRAEF staff costs at standard billing rates for GRAEF's time spent in efforts to collect. Client's obligation to pay GRAEF's collection costs shall survive the term of this Agreement or the earlier termination by either party.

Invoicing & Payment: GRAEF shall issue invoices for services on a monthly basis. Client shall remit payment within thirty (30) days of receipt of the invoice. **Prompt and full payment of all periodic invoices or other billings issued by GRAEF pursuant to this Agreement is of the essence of this Agreement.** In the event that Client fails to promptly and fully pay any invoice as and when due, then, and in addition to any other remedies allowed by law, GRAEF, may, in its sole discretion, suspend performance of all services under this Agreement upon seven (7) calendar days' written notice to Client, and immediately invoice Client for all unbilled work-in-progress rendered and other expenses incurred. Upon GRAEF's receipt of full payment, in good funds and without offset, of all sums invoiced in connection with any such declaration of suspension, GRAEF shall resume services, **provided that** the time schedule and compensation under this Agreement shall be equitably adjusted in a manner acceptable to GRAEF to compensate GRAEF for the period of suspension plus any other reasonable and necessary time and expenses GRAEF suffers or incurs to resume services. No failure by GRAEF to exercise its right to suspend work and accelerate sums due shall in any way waive or abridge Client's obligations to GRAEF or GRAEF's rights to later suspend work and accelerate terms. Client agrees GRAEF shall incur no liability whatsoever to Client, or to any other person, for any loss, cost or expense arising from any such suspension by GRAEF, either directly or indirectly. In addition, simple interest shall accrue at the lower of 1.5% per month (18% per annum), or the maximum interest rate allowable by law, on any invoiced amounts remaining unpaid for more than 60 days from the date of the invoice. Payments made shall be allocated as follows: (1) first to unpaid collection costs; (2) second to unpaid accrued interest; and (3) last to unpaid principal of the oldest invoice.

Latent Conditions: Client acknowledges that subsurface or latent physical conditions at the site that differ materially from those indicated in the project documents, or unknown or unusual conditions that materially differ from those ordinarily encountered may exist. If such latent conditions require a change in the design or the construction phase services, GRAEF shall be entitled to a reasonable extension of time to evaluate such change(s) and their impact on the project and to prepare such additional design documents as may be necessary to address or respond to such latent conditions. Client shall pay GRAEF for all services rendered and reimbursable expenses incurred by GRAEF and its subconsultant(s), if any, to address, respond to or repair such latent conditions. Such services by GRAEF or its subconsultant(s) shall constitute Additional Services.



collaborāte / formulāte / innovāte

Graef-USA Inc.'s TERMS AND CONDITIONS (continued)

Insurance: GRAEF shall procure and maintain liability insurance policies, including professional liability (of \$1,000,000 per claim), commercial general liability (of \$1,000,000 per occurrence and \$2,000,000 in the aggregate), automobile liability (of \$1,000,000), and workers' compensation insurance (in accordance with statutory limits) for the duration of this Agreement and shall, upon execution of the Agreement, produce certificates evidencing the maintenance of such coverages. Should Client desire additional insurance, GRAEF shall endeavor reasonably to procure and maintain such additional insurance, but Client shall reimburse GRAEF for any additional premiums or other related costs that GRAEF incurs.

Instruments of Service: Under this Proposal, the expectation is that GRAEF will provide Client with professional planning services, such as updating an existing Master Plan and development of a new Neighborhood Plan. Documents prepared for Client that relate to professional planning services shall become the property of Client. The Parties recognize that GRAEF has the capacity to handle engineering services as well. Although the Parties do not expect this Project to include engineering services, if engineering services are incorporated into this Project, no engineering documents prepared for Client by GRAEF or GRAEF's independent professional associate(s) and subconsultant(s) pursuant to this Agreement (including computer files, drawings, specifications, and reports) ("Engineering Documents") are intended or represented to be suitable for reuse by Client, unless GRAEF specifically consents to such reuse. Client's reuse of Engineering Documents shall be at Client's sole risk and responsibility.

Contractor Submittals: The scope of any review or other action taken by GRAEF or its subconsultant(s) in respect of any contractor submittal, such as shop drawings, shall be for the limited purpose of determining if the submission generally conforms with the overall intent of the design of the work that is the subject of this Agreement, but not for purposes of determining accuracy, completeness or other details such as dimensioning or quantities, or for substantiating instructions or performance of equipment or systems. GRAEF shall not be liable or responsible for any error, omission, defect or deficiency in any contractor submittal.

Pricing Estimates: Neither GRAEF nor Client has any control over the costs of labor, materials or equipment, over contractors' methods of determining bid prices, or over competitive bidding, market or negotiation conditions. Accordingly, GRAEF cannot and does not warrant or represent that bids or negotiated prices will not vary from any projected or established budgetary constraints.

Construction Observation: The Parties do not expect the Project to include construction. Unless expressly stated in this Agreement, GRAEF shall have no responsibility for Construction Observation. If Construction Observation services are performed, GRAEF's visits to the construction site shall be for the purpose of becoming generally familiar with the progress and quality of the construction, and to determine if the construction is being performed in general accordance with the plans and specifications. Unless expressly stated in a Scope of Work, GRAEF shall have no obligation to "inspect" the work of any contractor or subcontractor and shall have no control or right of control over and shall not be responsible for any construction means, methods, techniques, sequences, equipment or procedures (including, but not limited to, any erection procedures, temporary bracing or temporary conditions), or for safety precautions and programs in connection with the construction. Also, unless as expressly stated in a Scope of Work, GRAEF shall have no obligation for any defects or deficiencies or other acts or omissions of any contractor(s) or subcontractor(s) or material supplier(s), or for the failure of any of them to carry out the construction in accordance with the contract documents, including the plans and specifications. Unless expressly stated in a scope of work, GRAEF is not authorized to stop the construction or to take any other action relating to jobsite safety, which are solely the contractor's rights and responsibilities.

Dispute Resolution: GRAEF and Client shall endeavor to resolve all disputes first through direct negotiations between the parties' informed and authorized representatives, then through mediation. If mediation fails to fully resolve all disputes within 120 calendar days of the first written request for mediation, either party may pursue any remedy it deems appropriate to the circumstances.

No Assignment: This Agreement is not subject to assignment, transfer or hypothecation without the written consent of both parties expressly acknowledging such assignment, transfer or hypothecation.

Governing Law: This Agreement, as amended, and any disputes or controversies arising in connection with this Agreement shall be governed and resolved by the laws of the State of Wisconsin, without regard to said state's choice of law rules.

Severance of Clauses: In the event that any term, provision or condition of this Agreement is void or otherwise unenforceable under the law governing this Agreement, then such terms shall be stricken and the balance of this Agreement shall be interpreted and enforced as if such stricken terms never existed.

Integrated Agreement: The parties' final and entire agreement is expressed in the attached proposal letter and these Terms and Conditions. All prior oral agreements or discussions, proposals and/or negotiations between the parties are merged into and superceded by this Agreement. No term of the parties' Agreement may be orally modified, amended or superceded.



One Honey Creek Corporate Center
 125 South 84th Street, Suite 401
 Milwaukee, WI 53214-1470
 414 / 259 1500
 414 / 259 0037 fax
www.graef-usa.com

collaborāte / formulāte / innovāte

PROFESSIONAL SERVICES 2018 FEE SCHEDULE

CLASSIFICATION	RATE
Senior Group Manager (P9)	\$ 192.00
Group Manager (P8)	\$ 179.00
Senior Professional (P7)	\$ 169.00
Professional (P6)	\$ 159.00
Professional (P5)	\$ 149.00
Professional (P4)	\$ 139.00
Professional (P3)	\$ 126.00
Professional (P2)	\$ 113.00
Professional (P1)	\$ 100.00
Senior Technician/Inspector (T6)	\$ 126.00
Senior Technician/Inspector (T5)	\$ 119.00
Senior Technician/Inspector (T4)	\$ 110.00
Technician/Inspector (T3)	\$ 98.00
Technician/Inspector (T2)	\$ 87.00
Technician/Inspector (T1)	\$ 70.00
Survey Crew - 1 Person	\$ 130.00
Survey Crew - 2 Person	\$ 190.00
Administrative	\$ 70.00

Automobile travel will be billed at the current federal rate of 54.5 cents per mile.

Survey vehicles will be billed at 75 cents per mile.

LIDAR scanner will be billed at \$150/hour.

Unmanned Aircraft System (UAS) will be billed at \$75/hour.

Expenses such as travel and supplies will be billed at actual cost.

Contracted services and consultants will be billed at cost plus 5 percent.



collaborāte / formulāte / innovāte

WORK ORDER: 001

DATE: 2/25/2019

SERVICES PERFORMED AT:
City of Sheboygan, Wisconsin, downtown

POINT OF CONTACT AT GRAEF:
Kristan Grygiel Sanchez
Project Manager

BILL TO:
Chad Pelishek
Director of Planning & Development
City of Sheboygan
828 Center Ave.
Sheboygan, WI 53081

This work order amends the agreement dated February 25, 2019 and is subject to the GRAEF Terms and Conditions attached to that Agreement.

PROJECT NAME: Harbor Centre District Master Plan

PROJECT NUMBER: 2019-1050.01

DETAILED PROJECT DESCRIPTION:

Develop an update to the Harbor Centre District Master Plan, with services expected through August 30, 2019.

DETAILED DESCRIPTION OF SERVICES:

It is our understanding that the nature of the Project is to provide an update the Harbor Centre District Master Plan through the focus of a study area of four (4) subareas generally described as Downtown, Michigan Avenue corridor, Uptown district and Indiana Avenue corridor, and graphically depicted the attached diagram, Exhibit A.

TASKS:

1. Initiation | SWOT and district discussions
 - a. Meetings: up to two (2) meetings with committee or City staff, one in-person and one teleconference
 - b. Deliverables: SWOT analysis diagram
2. Economic Profiles | Existing conditions and district identities
 - a. Meetings: up to one (1) meeting with City staff, via teleconference
3. Activation | Public place and tactical activation recommendations
 - a. Meetings: up to two (2) meetings with City staff, stakeholders, or committee one in-person and one teleconference
 - b. Deliverables: interim memo of progress, if needed
4. Interactive Tool | Development of the tool and regulatory discussions
 - a. Meetings: up to two (2) working meetings with City staff, via teleconference
5. Final Deliverables | Final review and round of edits
 - a. District profile summaries (memo summary, meant as an internal staff tool)
 - b. Deliverable: Activation PDF tool

A more detailed outline of the Project Understanding and Basic Services is included in Exhibit B. The scope of work does not include approval and/or adoption with the City Council. It is understood that the City staff will take this up if desired or necessary.



collaborate / formulate / innovate

The GRAEF team's work is to be considered complete whether or not the project work is brought to the City Council for approval or adoption and is considered outside the scope of this project work.

For this Project, it is our understanding the Client will provide the following services, items and/or information:

- Convening space, outreach, invitations, and logistics for any meetings associated with this Project.
- Relevant files, data, and maps as it relates to the Project area.
- Prior plans, in an editable format (if available).
- Brand standards for the BID district in appropriate native file formats.
- Access and make all provisions necessary for GRAEF to enter public and/or private property as needed.
- Feedback, comments, and any necessary decisions or direction for the plan updates and designs.
- Regulatory and ordinance review and/or analysis as needed, specifically within Task 4.
- Public Notices for Public Meetings, if needed.
- Plan adoption/approval process as needed.

For all Basic Services, Client agrees to compensate GRAEF the not to exceed amount of \$33,734.00.

Please sign and date this copy and return a scanned fully-executed copy to us. Our team at GRAEF looks forward to providing services to the City of Sheboygan.

PROJECT APPROVAL:

Graef-USA Inc.

Brent T. Pitcher, PE, LEED AP
Vice President

Lawrence Witzling
Principal

ACCEPTED BY: City of Sheboygan

(Signature)

(Name Printed)

(Title)

Date: _____



collaborāte / formulāte / innovāte

EXHIBIT A

Project Study Area for Harbor Centre District Master Plan: Subareas 1-4



Not to scale



collaborāte / formulāte / innovāte

One Honey Creek Corporate Center
125 South 84th Street, Suite 401
Milwaukee, WI 53214-1470
414 / 259 1500
414 / 259 0037 fax
www.graef-usa.com

EXHIBIT B

Project Understanding for Harbor Centre District Master Plan

Note: The Study Area has been described within the diagram "Exhibit A."

1. Initiation | SWOT and district discussions

Our team begins the project with a data collection request with the City and a "soft kick-off" conference call with City staff. During the kick-off call, the team will discuss the overall project schedule and identify key milestones and public meeting dates. The GRAEF project manager will update the proposed project schedule which the team may use as a guide throughout the project.

The planning team will work with the City to generate a series of base maps based on the data request and available information. The data collection from the City and the maps will become the base for the meeting materials with the committee. It is our understanding that the committee will be selected and organized by the City, and will consist of City staff, the BID district, and key individuals (business and/or property owners; community organizations). The committee will not follow a formal meeting schedule and may be called upon from time to time throughout the project during review periods to participate in discussions and/or review concepts.

At the committee meeting, the GRAEF team will facilitate a discussion related to opportunities and weaknesses of the Study Area, known as a "SWOT" analysis. The group will also review precedents for placemaking (public space concepts and tactical activation concepts) to assist the team during the project. Following the meeting, the GRAEF team will use the information from the data collection and interpret the committee discussion into a graphic SWOT analysis diagram to summarize findings.

- a. Meetings: up to two (2) meetings with committee or City staff, one in-person and one teleconference
- b. Deliverables: SWOT analysis diagram

2. Market Profiles | Existing conditions and district identities

This task takes what we learned from the committee and combines it with market/economic data analysis, interviews with development and real estate professionals, and a site visit to begin uncovering the site-specific social, physical and economic elements of the district subareas. The team begins to identify the social spaces that are critical to the districts and tactical activation opportunities. A review of these findings are summarized in a meeting with City staff; results from this meeting will be incorporated into the remaining work. It is envisioned that Tasks 2 and 3 will overlap each other in the schedule, and the two tasks will rely on and inform the other.

- a. Meetings: up to one (1) meeting with City staff, via teleconference

3. Activation | Public place and tactical activation recommendations

While Task 2 focuses on market analysis, Task 3 will dive into the activation concepts for the subareas. Within each subarea, the team will review the site conditions and what we've learned throughout the project and identify 1-2 activation concepts for each subarea. The activation concepts are thought to be either physical place design concepts and/or "tactical activation." The GRAEF team is using the term "tactical activation" as a play on the

better-known tactical urbanism, but is meant to refer to temporary or permanent initiatives that meet City standards and regulations.

During this task the team will meet with stakeholders in a workshop or charrette style meeting. Following the meeting the team will revise the activation concepts as needed and then review with City staff. The place design concepts may be sketch-level concepts that may include a site plan sketch, a cross-section diagram, and/or a sketch over a street-level photo (elevation or perspective). The tactical activation concepts may be precedent examples combined with bulleted summaries.

- a. Meetings: up to two (2) meetings with City staff, stakeholders, or committee one in-person and one teleconference
- b. Deliverables: interim memo of progress, if needed

4. Interactive Tool | Development of the tool and regulatory discussions

The intent of this task is to create a tool to deploy the activation tactics to community partners, and create a framework for decision-making for City staff/officials (thought of as a decision-making matrix). The team will establish a structure for the document and work with City staff and the BID Director to integrate the new district brand standards to the degree determined feasible at that point in the project. The brand standards will be provided to the team by the City.

The tool is meant to provide ease of access to the concepts developed in this project for the public (business/property owners, community organizations, etc.). It is not meant to replace or update the City's zoning ordinance or site development standards currently in place. The team will use information provided to us by the City related to relevant ordinances and standards.

A mock-up of a portion of the document may be used during this task to guide these discussions and the final development of the deliverable.

- a. Meetings: up to two (2) working meetings with City staff, via teleconference

5. Final Deliverables | Final review and round of edits

With the development stage completed in Task 4, the team moves into the final task: delivering a final tool to City staff for review and comment. During this task we envision a review period with City staff to provide a set of comments and/or a markup. After a round of edits, the GRAEF team will provide a final deliverable back to the City.

The district identities that are developed during Task 2 will be summarized in a memo format to City staff. The memo is expected to be an internal document that the City staff and BID may use to help guide future economic development efforts in the subareas.

Note: the scope does not include public meetings (other than what is described above), and does not include the adoption and/or approval process.

- a. District profile summaries (memo, meant as an internal staff tool)
- b. Deliverable: Activation PDF tool



collaborāte / formulāte / innovāte

WORK ORDER: 002

DATE: 2/25/2019

SERVICES PERFORMED AT:

City of Sheboygan, Wisconsin, River South Neighborhood

POINT OF CONTACT AT GRAEF:

Kristan Grygiel Sanchez
Project Manager

BILL TO:

Chad Pelishek
Director of Planning & Development
City of Sheboygan
828 Center Ave.
Sheboygan, WI 53081

This work order amends the agreement dated February 25, 2019 and is subject to the GRAEF Terms and Conditions attached to that Agreement.

PROJECT NAME: River South Neighborhood Plan

PROJECT NUMBER: 2019-1050.02

DETAILED PROJECT DESCRIPTION:

Develop a River South Neighborhood Plan, with services expected through August 30, 2019.

DETAILED DESCRIPTION OF SERVICES:

It is our understanding that the nature of the Project is to provide a neighborhood plan for the River South area, studying the area for current neighborhood characteristics with a focus on potential future land uses, density and intensity of uses, and catalytic site redevelopment opportunities. The area of study is generally described as south of the Sheboygan River to Pennsylvania Avenue along N. 14th Street, and graphically depicted the attached diagram, Exhibit A.

TASKS:

1. Initiation | SWOT and open house listening sessions
 - a. Meetings: up to three (3) meetings total, one (1) with City staff via teleconference and up to two (2) public open house style in-person
 - b. Deliverables: SWOT analysis diagram and memo of open house
2. Physical and Social Characteristics | Existing conditions and future land uses
 - a. Meetings: none
3. Catalytic Site(s) | Recommendations about redevelopment opportunities
 - a. Meetings: up to two (2) meetings with City staff, teleconference
4. Final Deliverables | Final review and round of edits
 - a. Meetings: up to three (3) meetings, one (1) public open house style in-person and two (2) review meetings with City staff via teleconference
 - b. Deliverables: One (1) sketch-level color rendering of a selected development site, and final master plan PDF

A more detailed outline of the Project Understanding and Basic Services is included in Exhibit B. The scope of work does not include approval and/or adoption with the City Council. It is understood that the City staff will take this up if desired or necessary. The GRAEF team's work is to be considered complete whether or not the project work is brought to the City Council for approval or adoption and is considered outside the scope of this project work.



collaborāte / formulāte / innovāte

For this Project, it is our understanding the Client will provide the following services, items and/or information:

- Convening space, outreach, invitations, and logistics for any meetings associated with this Project.
- Relevant files, data, and maps as it relates to the Project area.
- Prior plans, in an editable format (if available).
- Access and make all provisions necessary for GRAEF to enter public and/or private property as needed.
- Feedback, comments, and any necessary decisions or direction for the plan updates and designs.
- Public Notices for Public Meetings, if needed.
- Plan adoption/approval process as needed.

For all Basic Services, Client agrees to compensate GRAEF the not to exceed amount of \$29,937.00.

Please sign and date this copy and return a scanned fully-executed copy to us. Our team at GRAEF looks forward to providing services to the City of Sheboygan.

PROJECT APPROVAL:

Graef-USA Inc.

Brent T. Pitcher, PE, LEED AP
Vice President

Lawrence Witzling
Principal

ACCEPTED BY: City of Sheboygan

(Signature)

(Name Printed)

(Title)

Date: _____



collaborāte / formulāte / innovāte

EXHIBIT A

Project Study Area for River South Neighborhood Plan

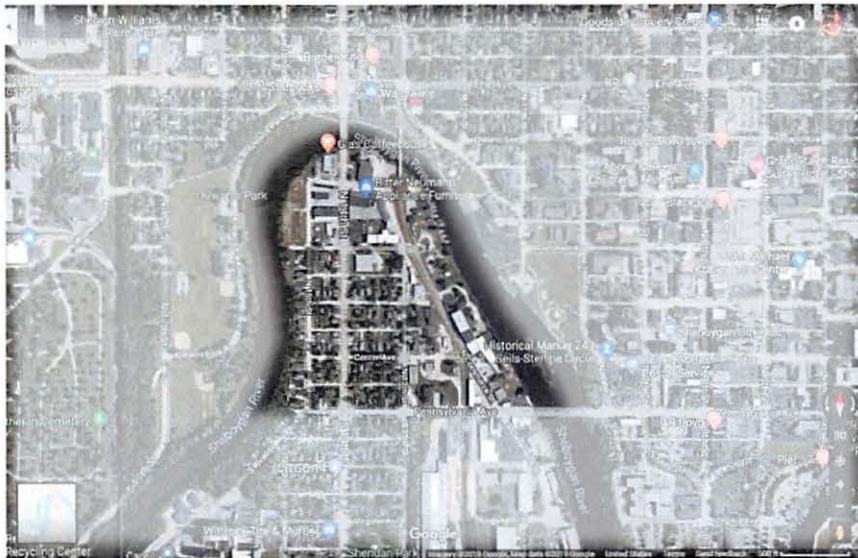

Study area depicted darker, with the ghosted area outside of the area of study.

Not to scale



EXHIBIT B

Project Understanding for River South Neighborhood Plan

Note: The Study Area has been described within the diagram "Exhibit A."

1. Initiation | SWOT and open house listening sessions

Our team begins the project with a data collection request with the City and a "soft kick-off" conference call with City staff. During the kick-off call, the team will discuss the overall project schedule and identify key milestones and public meeting dates. The GRAEF project manager will update the proposed project schedule which the team may use as a guide throughout the project. During this meeting the planning team will work with City staff to begin to understand the current conditions of the study area and the opportunities/challenges related to future growth.

The planning team will work with the City to generate a series of base maps based on the data request and available information. The data collection from the City and the maps will become the base for the meeting materials at the public open house listening sessions. The GRAEF team will facilitate up to two (2) public open house style meetings. Our idea is to host the meetings at a spot in the neighborhood, if feasible. In the scheduling, our aim would be to provide two alternate times of day to encourage participation.

At the City staff meeting, the GRAEF team will facilitate a discussion related to opportunities and weaknesses of the Study Area, known as a "SWOT" analysis. At the public open house, similar materials and structure will be used. The GRAEF team will then develop a graphic SWOT analysis diagram to summarize findings.

- a. Meetings: up to three (3) meetings total, one (1) with City staff via teleconference and up to two (2) public open house style in-person
- b. Deliverables: SWOT analysis diagram and memo of open house

2. Physical and Social Characteristics | Existing conditions and future land uses

This step in the process expands on the base knowledge gained in the initial SWOT analysis, building base information on the demographics, physical and social characteristics of the neighborhood. Mapping, analysis, and infographics of various types will be generated as the team work towards the integration into the final deliverable.

It is envisioned that Tasks 2 and 3 will overlap each other in the schedule, and the two tasks will rely on and inform the other.

- a. Meetings: none

3. Catalytic Site(s) | Recommendations about redevelopment opportunities

While Task 2 focuses on the neighborhood characteristics, Task 3 will explore redevelopment opportunities within the study area, and how those sites interact with the surrounding neighborhood. Up to three (3) sites (up to 5 acres in size each) will be selected in cooperation with City staff direction. Part of this work will be to discuss broader strategies for neighborhood reinvestment, as we look at and discuss the future growth and changes expected and desired in this part of the city over the next 5-10 years. In light of these findings, a



collaborāte / formulāte / innovāte

discussion with City staff will highlight the existing site development concepts that either support or inhibit the type of desired growth in the neighborhood. This is expected to be a higher-level review and will include a matrix of regulatory changes needed to support desired future neighborhood growth and change, and use typologies and visual preference-type images to illustrate the preferred type of growth. These findings will be integrated into the final deliverable.

- a. Meetings: up to two (2) meetings with City staff, teleconference

4. Final Deliverables | Final review and round of edits

With the analysis completed in Tasks 2 and 3, the team moves into the final task: delivering a final document to City staff for review and comment. During this task we envision a public open house style meeting to present some of the findings from Tasks 2 and 3, and includes a review period with City staff to provide a set of comments and/or a markup. After a round of edits, the GRAEF team will provide a final deliverable back to the City.

Note: the scope does not include public meetings (other than what is described above), and does not include the adoption and/or approval process.

- a. Meetings: up to three (3) meetings, one (1) public open house style in-person and two (2) review meetings with City staff via teleconference
- b. Deliverables: One (1) sketch-level color rendering of a selected development site, and final master plan PDF

IX

R. C. No. 265 - 18 - 19. By FINANCE AND PERSONNEL COMMITTEE. March 4, 2019.

Your Committee to whom was referred Gen. Ord. No. 42-18-19 by Alderpersons Rindfleisch and Bohren amending Section 82-33 of the Sheboygan Municipal Code so as to modify the City Administrator's Department Table of Organization; recommends approving the Ordinance with updated job description.

Ray

_____ Committee

I HEREBY CERTIFY that the foregoing Committee Report was duly accepted and adopted by the Common Council of the City of Sheboygan, Wisconsin, on the _____ day of _____, 20____.

Dated _____ 20____, _____, City Clerk

Approved _____ 20____, _____, Mayor

~~X~~

6.1

Gen. Ord. No. 42 - 18 - 19. By Alderpersons Rindfleisch and Bohren.
February 18, 2019.

AN ORDINANCE amending Section 82-33 of the Sheboygan Municipal Code so as to modify the City Administrator's Department Table of Organization.

THE COMMON COUNCIL OF THE CITY OF SHEBOYGAN DO ORDAIN AS FOLLOWS:

Section 1. Section 82-33 of the Sheboygan Municipal Code entitled "List of Classes and Class Specifications" is hereby amended so that Section A.7.b. of section 82-33 of the supplement to the Code on file in the city clerk's office is amended as follows:

Class Title	Class Grade	NO. of Employees
-------------	-------------	------------------

A. CITY HALL DEPARTMENTS

7. MAYOR / COMMON COUNCIL

DELETE:

7.b. Budget Analyst	I	1.0
---------------------	---	-----

ADD:

7.b. Assistant to the City Administrator	M	1.0
---	---	-----

~~Finance & Personnel~~
approve

Section 2. All ordinances or parts thereof in conflict with the provisions of this ordinance are hereby repealed to the extent of such conflict, and this ordinance and attached revised job description shall be in effect from and after its passage and publication.

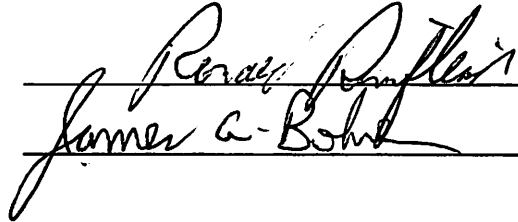

I HEREBY CERTIFY that the foregoing Ordinance was duly passed by the Common Council of the City of Sheboygan, Wisconsin, on the _____ day of _____, 20____.

Dated _____ 20____. _____, City Clerk

Approved _____ 20____. _____, Mayor

ASSISTANT TO THE CITY ADMINISTRATOR

POSITION PURPOSE



CITY OF SHEBOYGAN

Our Mission is to provide residents, the business community and visitors with fiscally responsible municipal services in an effective and responsive manner to meet the needs of our diverse community.

Our Vision is to be a family-oriented and prosperous community with a wide variety of housing, business, cultural and recreation opportunities in safe and attractive neighborhoods.

Our Values guide all actions and reflect what we require of our employees and expect from our elected officials. These core values set the high standard to which we expect to be measured.

Our Culture promotes an experience that is high-paced, unpretentious and meaningful while providing high-quality, services for the citizens of the City of Sheboygan.



GENERAL PURPOSE OF POSITIONS

City of Sheboygan employees uphold and promote the mission, vision and core values of the City of Sheboygan, and work to fulfill the six main principles of the Strategic Plan through these essential competencies:

- Respect
- Accountability
- Teamwork
- Innovation
- Fiscal Responsibility
- Service

Respect: Treating people with dignity and an attitude of caring and understanding. Showing genuine consideration for others. Valuing each individual as an individual.

Accountability: This value reflects our first and most important responsibility. Our competence is measured and, in fact, reinforced through active engagement of those we serve. We maintain an organizational reputation for openness, accountability, and integrity.

Teamwork: We are a team that emphasizes high levels of trust, full cooperation, and a commitment to thorough, effective communications within our city organization. We encourage employees to exercise independent judgment in meeting customer needs through professional behavior always consistent with our values.

Innovation: We acknowledge the weaknesses within government and create ethical, forward thinking solutions to overcome them. We identify, develop and deploy leading edge technology, employee development programs and process improvement tools.

Fiscal Responsibility: Proper use of public resources is a trust we continually guard. In management of this trust, we must avoid even the appearance of impropriety. In management of public funds, we constantly strive for the greatest possible efficiency, effectiveness, and quality outcome.

Service: Our primary duty is to the people we serve. We are accessible, consistent, responsive, and understanding. We provide assistance beyond our customers' expectations, and we find effective solutions to problems that they bring to our attention.

ASSISTANT TO THE CITY ADMINISTRATOR

POSITION PURPOSE



OFFICE OF THE CITY ADMINISTRATOR

Working with the Common Council, the community and city staff, the Office of the City Administrator's responsibility is to professionally implement all Common Council policy decisions and efficiently direct the city operation and activities in accordance with sound management principals. In addition, the City Administrator prepares, reviews, and monitors the annual operating budget for the city. The City Administrator also collaborates with the Mayor, City Attorney, and City Clerk.

Statement of Purpose

The function of the Office of the City Administrator is to professionally implement all Common Council policy decisions, efficiently direct the city operations, and creates an organizational culture that results in the delivery of excellent municipal services to constituents of Sheboygan.

Culture

The atmosphere throughout the city, as well as in the Office of the City Administrator, should be like getting together with friends or family. This means staff needs to provide an experience that is relaxed, casual, unpretentious, and fun while at the same time providing services that are high-quality, meaningful, and excellent.

Staff Expectations

The foremost item in every employee's job description is to handle problems and adversity with a positive attitude. That includes personal conflicts with others in the organization, design flaws in procedures, system breakdowns and all the other many mess ups and frustrations that can happen in this agency. All staff needs to help smooth the rough spots instead of making them worse through negativity. Staff needs to figure out a way to be in control, composed and genuinely friendly. Never treat customers as if they were one more problem or as if you are not pleased to have them here.

Equal Opportunity Employer

The City of Sheboygan, Wisconsin is an Equal Opportunity Employer In compliance with the Americans with Disabilities Act, the City of Sheboygan will provide reasonable accommodations to qualified individuals with disabilities and encourages both prospective and current employees to discuss potential accommodations with the employer.



For more about Sheboygan, visit www.sheboyganwi.gov

ASSISTANT TO THE CITY ADMINISTRATOR

POSITION PURPOSE



POSITION DESCRIPTION



Title:	Assistant to the City Administrator
Direct Supervisor:	City Administrator
Version Date:	02/24/2019
Salary Grade:	M
FLSA Status:	Exempt (Non-represented)

Position Summary

The Assistant to the City Administrator is a highly technical position responsible for completing various projects assigned by the City Administrator, as well as assisting and/or championing the development, design and implementation of the annual budget. Work primarily involves managing the timely flow of the budgeting process, providing leadership and assisting departments with budgetary problems and concerns; developing, designing and monitoring performance measures; long range trend analysis; compiling and leading the efforts needed to prepare the annual budget. Additional projects and/or assignments as needed, including projects unrelated to finance. The incumbent works under the general supervision of the City Administrator.

Essential Duties & Responsibilities

1. In conjunction with the Director of Finance, manages the development, review and publication of the annual budget in conformance with the long-range goal of the Long Term Financial Plan and annual budget parameters. Coordinate, with Department Heads, the development of useful performance measures and assists in the assimilation of those measures into department operation. Submits for award consideration.
2. Performs research and development of various projects, reports, periodic surveys, grant applications, and miscellaneous projects as needed throughout City operations, both related and unrelated to finance.
3. Assists Department Heads in the identification and resolution of budgetary opportunities and concerns throughout the year.
4. Assists the City Administrator in the development and monitoring of departmental budget.
5. In conjunction with the Director of Finance, creates and distributes Popular Annual Financial Report.
6. Oversees the coordination and publication of annual performance measurement report. Develops annual scorecard and award application. Participate in comparative benchmarking effort including electronic format.
7. Provides and presents long range trend analysis and other reports to identify concern areas of spending and the basis for long-term policy decisions.
8. Analyzes revenue trends and identifies concern areas; identifies service areas which may be possibly revenue supportive, monitor existing rates and recommend rate changes to reflect current cost of services.
9. Manage the development and update of capital improvements program.
10. Participates in the implementation and/or upgrades of budget-related MUNIS software system, particularly in integrating the account code structure with the budget categories and training of users.
11. Meets with and presents budgeting and financial issues to public groups and individuals.
12. Oversee the development, analysis and presentation of the annual community survey.
13. Oversee the development, presentation and publication of strategic plan and quarterly benchmark reports.
14. Develops and updates documents for the promotion of the department and the city, including social media and city website.
15. Provide support services for various committees including new member orientation.

ASSISTANT TO THE CITY ADMINISTRATOR

POSITION PURPOSE



Supervisory Responsibilities

There are no supervisory responsibilities required of this position. Periodically, perform lead role in directing and coordinating projects for interns.

Qualification Requirements

- Friendly, positive, cooperative professional, able to work with internal and external employees, vendors, and citizens in a professional capacity.
- Knowledge of rules and regulations of the Common Council relative to financial disbursements.
- Knowledge of performance measure budgeting and analysis.
- Ability to maintain financial records and accounts.
- Ability to prepare financial reports.
- Ability to close books and make necessary adjustments.
- Ability to assist in various aspects of budget preparation.
- Ability to work effectively under tight time constraints.
- Ability to communicate effectively, both orally and in writing with individuals both inside and outside the organization.
- Ability to perform various trend analysis, identify concerns and recommend long term solutions.
- Professional-level knowledge of Microsoft Office and Adobe products and the ability to work at a personal computer terminal for extended periods of time.
- Ability to adapt to financial software products.

Education & Experience

A Bachelor's degree in Public Administration, Political Science, Accounting, Business or a related field preferred. A minimum of three to five years of professional work experience in budget development and analysis and general accounting, and/or any equivalent combination of experience and training which provides the equivalent education, knowledge, abilities and skills, preferably in the public sector. A valid driver's license is also required.

Pre-Employment

Job offers for this position are contingent on the individual passing a pre-employment drug screen and background investigation.

Language Skills

Position requires the ability to work cooperatively and communicate effectively in written and verbal form. Prepare and maintain accurate and complete reports and records. Ability to prepare and present reports and make presentations as needed or required. Ability to work with all demographics preferred.

ASSISTANT TO THE CITY ADMINISTRATOR POSITION PURPOSE



Mathematical Skills

Knowledge of principles and practices of accounting, budgeting and finance in municipalities.

Reasoning Ability

Ability to act, make decisions and justify action based on rational thought, good judgment and logical thought.

Physical Demands

The physical demands described here are representative of those that must be met by an employee to successfully perform the essential functions of this job. Reasonable accommodations may be made to enable qualified individuals with disabilities to perform the essential functions. Work performed is primarily in a standard office environment that includes exposure to computer screens. Primary functions include sufficient physical ability and mobility to work in an office setting, sit and answer phones, and use of computer equipment on a continuous basis.

On a frequent basis, must have the ability to stand, walk, sit, talk, and reach with hands and arms and occasionally lift, bend, stoop and retrieve files and boxes weighing up to 25-30 pounds. Position requires the operation of office equipment and required repetitive hand movement and fine coordination including use of a computer keyboard.

Work with employees and/or the public that may be angry or upset. Maintains regular punctual and predictable attendance, works overtime and extra hours as required.

Work Environment

The work environment characteristics described here are representative of those an employee encounters while performing the essential functions of this job. Reasonable accommodations may be made to enable qualified individuals with disabilities to perform the essential functions.

Other Information

This job description includes the major duties and responsibilities of the job and is not to be construed as all-inclusive. The duties listed above are intended only as illustrations of the various types of work that may be performed. The omission of specific statements of duties does not exclude them from the position if the work is similar, related or is a logical assignment to the position.

This job description does not constitute an employment agreement between the employer and employee and is subject to change by the employer as the needs of the employer and requirements of the job change.

My signature below is both an acknowledgement of my understanding of the purpose of my position, as well as my commitment to uphold and promote the mission, vision and core values of the City of Sheboygan, and work to fulfill the six main principles of the Strategic Plan.

Employee Name: _____ Date: _____

Employee Signature: _____

ASSISTANT TO THE CITY ADMINISTRATOR POSITION PURPOSE



YEARLY PERFORMANCE EVALUATION



Employee Name:

Performance Period:

1. Employee to review the following by reading (aloud):
 - a. City's Mission, Vision and Values
 - b. Six essential competencies needed to fulfill the purpose of the position
 - c. Your department's Mission, Vision, and Values
2. Do you understand the purpose of your position?
3. Does your performance meet the expectations identified in the six main principles of the city's strategic plan and these essential competencies:
 - a. Respect
 - b. Accountability
 - c. Teamwork
 - d. Innovation
 - e. Fiscal Responsibility
 - f. Service
4. If yes, what actions are you going to continue? If no, what modifications are you going to make in order to meet the expectations of your position?



For more about Sheboygan, visit www.sheboyganwi.gov

IX

R. C. No. 266- 18 - 19. By FINANCE AND PERSONNEL COMMITTEE. March 4, 2019.

Your Committee to whom was referred Gen. Ord. No. 43-18-19 by Alderpersons Rindfleisch and Bohren amending Section 82-33 of the Sheboygan Municipal Code so as to modify the Senior Activity Center Table of Organization; recommends approving the Ordinance with updated job description.

Ref.

Committee

I HEREBY CERTIFY that the foregoing Committee Report was duly accepted and adopted by the Common Council of the City of Sheboygan, Wisconsin, on the _____ day of _____, 20____.

Dated _____ 20____. _____, City Clerk

Approved _____ 20____. _____, Mayor

~~X~~

6.2

Gen. Ord. No. 43 - 18 - 19. By Alderpersons Rindfleisch and Bohren.
February 18, 2019.

AN ORDINANCE amending Section 82-33 of the Sheboygan Municipal Code so as to modify the Senior Activity Center Table of Organization.

THE COMMON COUNCIL OF THE CITY OF SHEBOYGAN DO ORDAIN AS FOLLOWS:

Section 1. Section 82-33 of the Sheboygan Municipal Code entitled "List of Classes and Class Specifications" is hereby amended so that Section A.10. of section 82-33 of the supplement to the Code on file in the city clerk's office is amended as follows:

Class Title	Class Grade	NO. of Employees
-------------	-------------	------------------

A. CITY HALL DEPARTMENTS

10. SENIOR ACTIVITY CENTER

DELETE:

Senior Activity Center Supervisor	I	1.0
-----------------------------------	---	-----

ADD:

Director of Senior Services	K	1.0
-----------------------------	---	-----

~~Finances~~
Personnel
approve

Section 2. All ordinances or parts thereof in conflict with the provisions of this ordinance are hereby repealed to the extent of such conflict, and this ordinance and attached revised job description shall be in effect from and after its passage and publication.

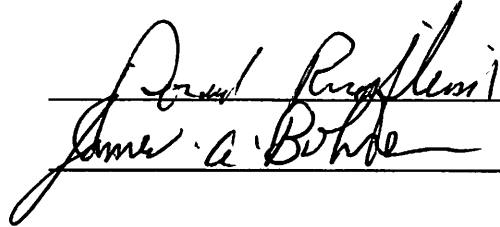

I HEREBY CERTIFY that the foregoing Ordinance was duly passed by the Common Council of the City of Sheboygan, Wisconsin, on the _____ day of _____, 20____.

Dated _____ 20____. _____, City Clerk

Approved _____ 20____. _____, Mayor

DIRECTOR OF SENIOR SERVICES

POSITION PURPOSE



CITY OF SHEBOYGAN

Our Mission is to provide residents, the business community and visitors with fiscally responsible municipal services in an effective and responsive manner to meet the needs of our diverse community.

Our Vision is to be a family-oriented and prosperous community with a wide variety of housing, business, cultural and recreation opportunities in safe and attractive neighborhoods.

Our Values guide all actions and reflect what we require of our employees and expect from our elected officials. These core values set the high standard to which we expect to be measured.

Our Culture promotes an experience that is fast-paced, unpretentious and meaningful while providing high-quality services for the citizens of the City of Sheboygan.



GENERAL PURPOSE OF POSITIONS

City of Sheboygan employees uphold and promote the mission, vision and core values of the City of Sheboygan, and work to fulfill the six main principles of the Strategic Plan through these essential competencies:

- Respect
- Accountability
- Teamwork
- Innovation
- Fiscal Responsibility
- Service

Respect: Treating people with dignity and an attitude of caring and understanding. Showing genuine consideration for others. Valuing each individual as an individual.

Accountability: This value reflects our first and most important responsibility. Our competence is measured and, in fact, reinforced through active engagement of those we serve. We maintain an organizational reputation for openness, accountability, and integrity.

Teamwork: We are a team that emphasizes high levels of trust, full cooperation, and a commitment to thorough, effective communications within our city organization. We encourage employees to exercise independent judgment in meeting customer needs through professional behavior always consistent with our values.

Innovation: We acknowledge the weaknesses within government and create ethical, forward thinking solutions to overcome them. We identify, develop and deploy leading edge technology, employee development programs and process improvement tools.

Fiscal Responsibility: Proper use of public resources is a trust we continually guard. In management of this trust, we must avoid even the appearance of impropriety. In management of public funds, we constantly strive for the greatest possible efficiency, effectiveness, and quality outcome.

Service: Our primary duty is to the people we serve. We are accessible, consistent, responsive, and understanding. We provide assistance beyond our customers' expectations, and we find effective solutions to problems that they bring to our attention.

DIRECTOR OF SENIOR SERVICES

POSITION PURPOSE



SENIOR SERVICES

To encourage all citizens, especially older adults, to remain active and engaged in their community.

- The vibrancy and health of our organization depends upon the investment of each individual.
- We believe in the inherent value of ALL people.
- We believe in building collaborative relationships.
- We believe that older adults have talent and wisdom to share and are an important community resource.

Statement of Purpose

The function of the Senior Services Department is to serve our customers in a way that establishes a relationship of mutual gratitude- our gratitude for our customer's patronage, and our customer's gratitude for the quality and value they receive. To build this relationship, we regularly ask our customers if their expectations are met and if they find value in the activities offered and services received.

Culture

The atmosphere throughout the city, as well as in the Senior Services Department, should be like getting together with friends or family. This means staff members need to provide an experience that is relaxed, casual, unpretentious, and fun while providing services that are high-quality and meaningful for all.

Staff Expectations

The foremost item in every employee's job purpose is to be pro-active in providing programs and services yet be able to handle problems and adversity with a positive attitude. That includes personal conflicts with others in the organization, design flaws in procedures, system breakdowns and all the other many mess ups and frustrations that can happen in this agency. All staff members need to help smooth the rough spots instead of making them worse through negativity. Staff needs to figure out a way to be in control, composed and genuinely friendly. Never treat customers as if they were one more problem or as if you are not pleased to have them here.

Equal Opportunity Employer

The City of Sheboygan, Wisconsin is an Equal Opportunity Employer In compliance with the Americans with Disabilities Act, the City of Sheboygan will provide reasonable accommodations to qualified individuals with disabilities and encourages both prospective and current employees to discuss potential accommodations with the employer.



For more about Sheboygan, visit www.sheboyganwi.gov

DIRECTOR OF SENIOR SERVICES

POSITION PURPOSE



POSITION DESCRIPTION



Title: Director of Senior Services
Version Date: 02/24/2019
Salary Grade: K
FLSA Status: Exempt

Position Summary

The Director of Senior Services actively develops or participates in city-wide activities for citizens of all ages, as well as oversees the operation and maintenance of the Activity Center and ensures all programs meet the needs of those 55 and over in the City of Sheboygan. The position works under the limited supervision of the City Administrator.

Essential Duties & Responsibilities

1. To enhance the quality of life for citizens, with emphasized focus on seniors within the community, by developing programs and/or participating in various community-sponsored events in an effort to increase engagement and participation of citizens.
2. Prepares and oversees the annual budget for the Senior Services Department.
3. Assists in the preparation and oversees the Friends of SACS annual budget.
4. Coordinate, oversee and make public presentations for the work of the Sheboygan For All Livability Task Group.
5. Manages the daily operation of building services, HVAC, gas, electricity, alarms, emergency procedures and security issues and troubleshoots problems.
6. Oversees the preparation and distribution of monthly agendas, Supervisor's reports, financial reports and quarterly benchmark reports for SACS Commission and the Board of the Friends of the Senior Activity Center.
7. Purchases and manages the utilization of all center equipment including computers, copy machine, telephone system, video, electronic and sound equipment, office supplies, decorations, furniture, household and janitorial supplies.
8. Increases public awareness of the center's programs and services through public speaking, presentations, community networking and development of business and community partnerships.
9. Regularly evaluates Senior Activity Center services and programs and recommends improvements.
10. Coordinates community groups' utilization of the Senior Activity Center and obtains building use agreements from outside groups and organizations.
11. Provides leadership and direction in the development of short and long term plans.
12. Prepares various legal documents, vouchers, letters, memos and other correspondence pertaining to Senior Services Department.
13. Maintains and updates contracts with outside vendors, guest presenters, sponsors and program leaders.
14. Oversees marketing and communication efforts for SACS programs and events.
15. Attends Senior Services Commission meetings and sub-committee meetings and delivers ongoing reports.
16. Attends Friends of SACS Board meetings and sub-committee meetings and makes recommendations for the enhancement of the facility and programs offered at their request.

DIRECTOR OF SENIOR SERVICES

POSITION PURPOSE



Supervisory Responsibilities

Trains, supervises and evaluates Senior Services Department staff hired by the City of Sheboygan, those hired by the Friends of the Senior Activity Center, voluntary program leaders and volunteers.

Sets up daily work schedules for adequately staffing the operations of the center and complies with the City of Sheboygan and Friends Memorandum of Understanding for supervision of the building.

Directs and enforces compliance with all City personnel and safety policies and regulations and department policies and regulations.

Qualification Requirements

Position requires knowledge of principles and practices of effective employee supervision, including selection, training, evaluation and discipline and skills in planning, organizing, assigning, directing, reviewing and evaluating the work of assigned staff and volunteers.

Ability needed to motivate staff and implement goals, objectives, policies, procedures, work standards and internal controls.

Ability needed to plan, organize and implement multi-faceted senior programs and activities.

Experience and the ability to work cooperatively and effectively with, and make presentations to, older adults, staff and other City personnel, members of the Senior Services Commission, Common Council, Friends of the Senior Activity Center and other community organizations.

PC literacy including working knowledge of software including: Internet Explorer, Microsoft Word, Microsoft Publisher, Excel, Munis and Quikbooks Accounting systems.

Position requires a high sense of responsibility and initiative to work independently and productively without direct supervision and to work effectively from written and verbal instructions. Must champion and/or oversee a monthly newsletter and professionally correspond with organizations such as the Sheboygan Press, AARP, etc.

Education & Experience

A Bachelor's degree is required in a field relating to business, non-profit or related, plus and a minimum of three years of professional work experience, including direct supervisory experience. Experience in planning/conducting activities/ programs in a senior adult recreation environment preferred.

Pre-Employment

Job offers for this position are contingent on the individual passing a pre-employment drug screen, background check and psychological review.

Language Skills

Ability to communicate effectively and professionally in both written and verbal form. Prepare and maintain accurate and complete reports and records. Ability to prepare and present Annual Report to Common Council and make presentations and requests before the Common Council as needed.

DIRECTOR OF SENIOR SERVICES

POSITION PURPOSE



Mathematical Skills

Knowledge of basic budgeting principles.

Reasoning Ability

Ability to act, make decisions and justify action based on rational thought, good judgment and logical thought.

Physical Demands

The physical demands described here are representative of those that must be met by an employee to successfully perform the essential functions of this job. Reasonable accommodations may be made to enable qualified individuals with disabilities to perform the essential functions.

While performing the duties of this job, the employee is regularly required to talk or hear. The employee frequently is required to sit. The employee is occasionally required to stand and walk.

The employee must regularly lift and/or move up to 10 pounds.

Work Environment

The work environment characteristics described here are representative of those an employee encounters while performing the essential functions of this job. Reasonable accommodations may be made to enable qualified individuals with disabilities to perform the essential functions.

The City of Sheboygan, Wisconsin is an Equal Opportunity Employer. In compliance with the Americans with Disabilities Act, the City of Sheboygan will provide reasonable accommodations to qualified individuals with disabilities and encourages both prospective and current employees to discuss potential accommodations with the employer.

Other Information

This job description includes the major duties and responsibilities of the job and is not to be construed as all-inclusive. The duties listed above are intended only as illustrations of the various types of work that may be performed. The omission of specific statements of duties does not exclude them from the position if the work is similar, related or is a logical assignment to the position.

This job description does not constitute an employment agreement between the employer and employee and is subject to change by the employer as the needs of the employer and requirements of the job change.

My signature below is both an acknowledgement of my understanding of the purpose of my position, as well as my commitment to uphold and promote the mission, vision and core values of the City of Sheboygan, and work to fulfill the six main principles of the Strategic Plan.

Employee Name: _____ Date: _____

Employee Signature: _____

DIRECTOR OF SENIOR SERVICES

POSITION PURPOSE



YEARLY PERFORMANCE EVALUATION



Employee Name:

Performance Period:

1. Employee to review the following by reading (aloud):
 - a. City's Mission, Vision and Values
 - b. Six essential competencies needed to fulfill the purpose of the position
 - c. Your department's Mission, Vision, and Values
2. Do you understand the purpose of your position?
3. Does your performance meet the expectations identified in the six main principles of the city's strategic plan and these essential competencies:
 - a. Respect
 - b. Accountability
 - c. Teamwork
 - d. Innovation
 - e. Fiscal Responsibility
 - f. Service
4. If yes, what actions are you going to continue? If no, what modifications are you going to make in order to meet the expectations of your position?



For more about Sheboygan, visit www.sheboyganwi.gov

IV

R. C. No. _____ - 18 - 19. By FINANCE AND PERSONNEL COMMITTEE. March 4, 2019.

Your Committee to whom was referred Gen. Ord. No. 44-18-19 by Alderpersons Rindfleisch and Bohren amending Section 82-33 of the Sheboygan Municipal Code so as to modify the City Development Department/Building Inspection Division Table of Organization; recommends approving the Ordinance.

Reg.

_____	_____
_____	_____
_____	_____

Committee

I HEREBY CERTIFY that the foregoing Committee Report was duly accepted and adopted by the Common Council of the City of Sheboygan, Wisconsin, on the _____ day of _____, 20____.

Dated _____ 20____. _____, City Clerk

Approved _____ 20____. _____, Mayor

~~X~~

6.3

Gen. Ord. No. 44-18-19. By Alderpersons Rindfleisch and Bohren.
February 18, 2019.

AN ORDINANCE amending Section 82-33 of the Sheboygan Municipal Code so as to modify the City Development Department/Building Inspection Division Table of Organization.

THE COMMON COUNCIL OF THE CITY OF SHEBOYGAN DO ORDAIN AS FOLLOWS:

Section 1. Section 82-33 of the Sheboygan Municipal Code entitled "List of Classes and Class Specifications" is hereby amended so that Section A.3.b. of section 82-33 of the supplement to the Code on file in the city clerk's office is amended as follows:

Class Title	Class Grade	No. of Employees
-------------	-------------	------------------

A. CITY HALL DEPARTMENTS

3. CITY DEVELOPMENT DEPARTMENT

DELETE:

3.b. Electrical/Housing Inspector	K	1.0
-----------------------------------	---	-----

ADD:

3.b. Building Inspection Licensing Clerk	E	1.0
--	---	-----

Finance and Personnel approve

Section 2. All ordinances or parts thereof in conflict with the provisions of this ordinance are hereby repealed to the extent of such conflict, and this ordinance and attached revised job description shall be in effect from and after its passage and publication.

Ronald R. Ruffalo
James A. Bohre

I HEREBY CERTIFY that the foregoing Ordinance was duly passed by the Common Council of the City of Sheboygan, Wisconsin, on the _____ day of _____, 20____.

Dated _____ 20____. _____, City Clerk
Approved _____ 20____. _____, Mayor



Job Description

Job Title: **Building Inspection Licensing Clerk** **Department:** City Development/
Building Inspection Division

Date Issue: January 2019 **Reports To:** Director of Planning and Development

Classification: Non-Exempt **Wage:** Salary Grade E

Position Summary

Under the general direction of the Director of Planning and Development, performs a wide range of diverse and responsible duties pertaining to a variety of building inspection services requiring individual judgment, initiative, and specialized knowledge in carrying out procedures and applying laws and regulations.

Essential Duties & Responsibilities

1. Issues permits, collects fees, issues receipts, and provides assistance to the general public, contractors, developers, realtors, architects, and designers who visit, call, or write about building and construction services.
2. Confers with planners, building inspectors, engineers and staff on developmental plans, policies, specifications or construction documents for compliance with City Ordinances, State Building Codes and other regulations.
3. Determines compliance with rules and regulations affecting accessory residential buildings.
4. Ascertains whether or not proposed alterations and repairs conform to zoning requirements.
5. Responsible for the complete licensing process relative to the application, receipt of fees and issuances of building trades contractor licensing, maintaining insurance database, and correspondence with the State of Wisconsin Department of Professional Services.
6. Reviews applications for fence permits, retaining walls, decks, etc.
7. Performs various receptionist/clerical activities including: greeting customers, telephone receptionist duties, processing mail, composing and typing letters and memoranda from general instructions, preparation of agendas, and assistance with the preparation of contractor license applications, etc.
8. Maintains computerized cash receipts and other records as required.
9. Schedules appointments, issues certificates, and maintains customer contact log for Clearwater Program.
10. Processes municipal court citations issued by Inspectors including: reviewing for accuracy, entering into division's recordkeeping system, transmission to Municipal Court, and submission of pertinent documents to City Attorney's Office.
14. Maintains records of projects reviewed and inspection records.
15. Schedules appointments and processes paperwork/certificates for the Inspectors.
16. Orders and maintains division office forms and supplies.
17. Performs other related work as assigned.

Qualification Requirements:

1. Ability to communicate effectively both orally and in writing.
2. Extensive knowledge of the laws, codes, principles, practices, methods, and techniques as applied to and pertaining to the various aspects of building inspection, building code, code enforcement, zoning, planning, etc.
3. Ability to read and interpret plans, specifications, construction documents, codes and municipal ordinances.
4. Ability to obtain a satisfactory grade on clerical examinations involving English, spelling, business math, clerical accuracy, etc., and high level of proficiency in typing and transcription accurately.
5. Extensive knowledge of computers and programs (Microsoft Word, Outlook, Excel, PowerPoint, AS 400, MUNIS etc.)
6. Ability to be exercise good judgment, courtesy, and tact in dealing with the general public, property owners, contractors, architects, engineers, and designers.
7. Ability to answer a variety of questions and make appropriate referrals to inspectors and/or the division director.
8. Ability to establish and maintain efficient working relationships with City officials, boards and committees, and City staff.

Education and/or Experience

High school diploma or a GED Certificate recognized by the Wisconsin Department of Public Instruction, in addition to post high school courses relating to business and/or bookkeeping and/or other job-related course work.

Four years of progressively responsible office experience, including experience in the building trades or construction background.

Pre-employment Requirement

Job offers for this position are contingent on the individual passing a pre-employment drug screen.

The City of Sheboygan, Wisconsin is an Equal Opportunity Employer

In compliance with the Americans with Disabilities Act, the City of Sheboygan will provide reasonable accommodations to qualified individuals with disabilities and encourages both prospective and current employees to discuss potential accommodations with the employer.

IX

R. C. No. 267 - 18 - 19. By FINANCE AND PERSONNEL COMMITTEE. March 4, 2019.

Your Committee to whom was referred Gen. Ord. No. 46-18-19 by Alderpersons Rindfleisch and Bohren amending Section 82-33 of the Sheboygan Municipal Code so as to modify the Department of Finance Table of Organization; recommends approving the Ordinance with updated job description.

Reg.

_____	_____
_____	_____
_____	_____

Committee

I HEREBY CERTIFY that the foregoing Committee Report was duly accepted and adopted by the Common Council of the City of Sheboygan, Wisconsin, on the _____ day of _____, 20____.

Dated _____ 20____. _____, City Clerk

Approved _____ 20____. _____, Mayor

Gen. Ord. No. 46 - 18 - 19. By Alderpersons Rindfleisch and Bohren.
February 18, 2019.

AN ORDINANCE amending Section 82-33 of the Sheboygan Municipal Code so as to modify the Department of Finance Table of Organization.

THE COMMON COUNCIL OF THE CITY OF SHEBOYGAN DO ORDAIN AS FOLLOWS:

Section 1. Section 82-33 of the Sheboygan Municipal Code entitled "List of Classes and Class Specifications" is hereby amended so that Section A.5.a. of section 82-33 of the supplement to the Code on file in the city clerk's office is amended as follows:

<u>Class Title</u>	<u>Class Grade</u>	<u>No. of Employees</u>
--------------------	--------------------	-------------------------

A. CITY HALL DEPARTMENTS

5. Department of Finance

a. Accounting Division

DELETE:

Finance / Accounting Specialist (Temp/1 Year)	K	1.0
--	---	-----

ADD:

Finance / Accounting Specialist	K	1.0
---------------------------------	---	-----

*Frances Personnel
approve*

SENIOR ACCOUNTANT POSITION PURPOSE



CITY OF SHEBOYGAN

Our Mission is to provide residents, the business community and visitors with fiscally responsible municipal services in an effective and responsive manner to meet the needs of our diverse community.

Our Vision is to be a family-oriented and prosperous community with a wide variety of housing, business, cultural and recreation opportunities in safe and attractive neighborhoods.

Our Values guide all actions and reflect what we require of our employees and expect from our elected officials. These core values set the high standard to which we expect to be measured.

Our Culture promotes an experience that is professionally challenging, fast-paced and unpretentious while providing high-quality, meaningful services for the citizens.



GENERAL PURPOSE OF POSITIONS

City of Sheboygan employees uphold and promote the mission, vision and core values of the City of Sheboygan, and work to fulfill the six main principles of the Strategic Plan through these essential competencies:

- Respect
- Accountability
- Teamwork
- Innovation
- Fiscal Responsibility
- Service

Respect: Treating people with dignity and an attitude of caring and understanding. Showing genuine consideration for others. Valuing each individual as an individual.

Accountability: This value reflects our first and most important responsibility. Our competence is measured and, in fact, reinforced through active engagement of those we serve. We maintain an organizational reputation for openness, accountability, and integrity.

Teamwork: We are a team that emphasizes high levels of trust, full cooperation, and a commitment to thorough, effective communications within our city organization. We encourage employees to exercise independent judgment in meeting customer needs through professional behavior always consistent with our values.

Innovation: We acknowledge the weaknesses within government and create ethical, forward thinking solutions to overcome them. We identify, develop and deploy leading edge technology, employee development programs and process improvement tools.

Fiscal Responsibility: Proper use of public resources is a trust we continually guard. In management of this trust, we must avoid even the appearance of impropriety. In management of public funds, we constantly strive for the greatest possible efficiency, effectiveness, and quality outcome.

Service: Our primary duty is to the people we serve. We are accessible, consistent, responsive, and understanding. We provide assistance beyond our customers' expectations, and we find effective solutions to problems that they bring to our attention.

SENIOR ACCOUNTANT POSITION PURPOSE



FINANCE DIVISION

Under the direction of the Finance Director, the Senior Accountant coordinates and controls financial transactions of the city; prepares documents, assists with the annual audit, payments of city invoices and cash receipting, maintains compliance with all state and federal laws; supplies meaningful and timely financial data that will inform and assist departments and city management.

Statement of Purpose

The function of the Finance Department is to provide administration of the accounting system, purchasing, investment, cash management, cash receipting, accounts payable, debt management, and assessing. Maintains fixed asset inventory and property insurance replacement value, prepare and publish Annual Financial Report and Budget Report. The division also is responsible for the Debt Service Fund, TIF Funds, Capital Funds and Special Assessment Fund.

HUMAN RESOURCES DIVISION

The Human Resources Department is responsible for recruitment of qualified applicants, employee orientation, maintenance of personnel records, administration of employee benefits, retirement processing, compensation administration, job classification and labor market research, employee relations, labor negotiations, health and wellness administration, and regulatory compliance.

Statement of Purpose

The function of the Human Resources Department is to provide applicants and employees to various departments to successfully serve the City of Sheboygan and to provide employees with appropriate compensation and benefits programs both during employment and into retirement.



For more about Sheboygan, visit www.sheboyganwi.gov

SENIOR ACCOUNTANT POSITION PURPOSE



Culture

The atmosphere throughout the city, as well as in the Finance and Human Resources Departments, strives for positive cooperation throughout all departments. This means staff provide an experience that is user-friendly and unpretentious, and at the same time providing services that are high-quality, meaningful, and appropriate for the request

Staff Expectations

The foremost item in every employee's job description is to handle problems and adversity with a positive attitude. That includes personal conflicts with others in the organization, design flaws in procedures, system breakdowns and all the other many mess ups and frustrations that can happen in this agency. All staff needs to help smooth the rough spots instead of making them worse through negativity. Staff needs to figure out a way to be in control, composed and genuinely friendly. Never treat customers as if they were one more problem or as if you are not pleased to have them here.

Equal Opportunity Employer

The City of Sheboygan, Wisconsin is an Equal Opportunity Employer In compliance with the Americans with Disabilities Act, the City of Sheboygan will provide reasonable accommodations to qualified individuals with disabilities and encourages both prospective and current employees to discuss potential accommodations with the employer.



For more about Sheboygan, visit www.sheboyganwi.gov

SENIOR ACCOUNTANT POSITION PURPOSE



POSITION DESCRIPTION



Title:	Senior Accountant
Direct Supervisor:	Finance Director
Department:	Finance
Version Date:	02/28/19
Salary Grade:	K
FLSA Status:	Fulltime, Exempt (Non-represented)

Position Summary

The Senior Account is responsible for providing senior-level experience in Finance, directly supporting the Finance Director and Finance Department by performing specific financial and administrative functions. The position will assist or maintain controls over all general ledger accounts with principal operation to the extent necessary to establish, maintain and audit controls over input and output of detailed transaction reports, as well as performs other related work including preparation of reports to outside agencies as required.

As a representative of the Finance Department, this position has regular interaction with employees, the public and other agencies and is critical to the success of the City of Sheboygan.

Essential Duties & Responsibilities

1. Senior-level, skilled finance professional, capable of assisting the Finance Director with a high degree of skill and ability with various functions through the Finance Department.
2. Capable of performing detailed work within the department from inception to completion.
3. Audits and compiles all information in the support of journal entries and prepares all journal entries subject to review and approval by the Finance Director or his/her delegate.
4. Maintains account controls and analyses or reviews details established by other sources such as data processing for all City general ledger accounts.
5. Maintains and audits subsidiary records for grants, insurance, bank reconciliation, and other specific areas which require the production of periodic reports and prepares the related reports subject to review and approval by the Finance Director or his/her delegate.
6. Reviews and verifies all activity including account distribution of all source data posted to the general ledger.
7. Performs internal auditing of all department records and procedures including inventory, cash receipts, and other financial transactions.
8. Maintains, audits and compiles information for fixed asset system.

Supervisory Responsibilities

There are no supervisory responsibilities required of this position.

Qualification Requirements

Position requires a high sense of responsibility and initiative to work independently and productively without supervision and to work from oral and written instructions. The position requires the ability to assist in properly scheduling data runs, interpret and maintain federal and state aid programs, coordinate and participate in accounting and bookkeeping operations and to prepare complex financial reports and other records.

SENIOR ACCOUNTANT POSITION PURPOSE



Language Skills

Position requires the ability to work cooperatively and communicate effectively in written and verbal form.

Mathematical Skills

Position requires considerable knowledge of accounting, internal auditing and mathematics.

Reasoning Ability

Ability exercise excellent judgment, courtesy and tact in maintaining effective public and employee relations.

Education & Experience

A Bachelor's degree in Accounting, Business or a related field is required, with a minimum of three years of professional senior experience in general accounting, payroll, employee benefits administration, financial analysis and/or any equivalent combination of experience and training which provides the equivalent education, knowledge, abilities and skills.

A valid driver's license is also required.

Pre-Employment

Job offers for this position are contingent on the individual passing a pre-employment drug screen and background investigation.

Physical Demands

The physical demands described here are representative of those that must be met by an employee to successfully perform the essential functions of this job. Reasonable accommodations may be made to enable qualified individuals with disabilities to perform the essential functions. Work performed is primarily in a standard office environment that includes exposure to computer screens. Primary functions include sufficient physical ability and mobility to work in an office setting, sit and answer phones, and use of computer equipment on a continuous basis.

On a frequent basis, must have the ability to stand, walk, sit, talk, and reach with hands and arms and occasionally lift, bend, stoop and retrieve files and boxes weighing up to 25-30 pounds. Position requires the operation of office equipment and required repetitive hand movement and fine coordination including use of a computer keyboard.

Work with employees and/or the public that may be angry or upset. Maintains regular punctual and predictable attendance, works overtime and extra hours as required.

Work Environment

The work environment characteristics described here are representative of those an employee encounters while performing the essential functions of this job. Reasonable accommodations may be made to enable qualified individuals with disabilities to perform the essential functions.

SENIOR ACCOUNTANT POSITION PURPOSE



Other Information

This job description includes the major duties and responsibilities of the job and is not to be construed as all-inclusive. The duties listed above are intended only as illustrations of the various types of work that may be performed. The omission of specific statements of duties does not exclude them from the position if the work is similar, related or is a logical assignment to the position.

This job description does not constitute an employment agreement between the employer and employee and is subject to change by the employer as the needs of the employer and requirements of the job change.

My signature below is both an acknowledgement of my understanding of the purpose of my position, as well as my commitment to uphold and promote the mission, vision and core values of the City of Sheboygan, and work to fulfill the six main principles of the Strategic Plan.

Employee Name: _____ Date: _____

Employee Signature: _____

SENIOR ACCOUNTANT POSITION PURPOSE



YEARLY PERFORMANCE EVALUATION



Employee Name:

Performance Period:

1. Employee to review the following by reading (aloud):
 - a. City's Mission, Vision and Values
 - b. Six essential competencies needed to fulfill the purpose of the position
 - c. Your department's Mission, Vision, and Values

2. Do you understand the purpose of your position?

3. Does your performance meet the expectations identified in the six main principles of the city's strategic plan and these essential competencies:
 - a. Respect
 - b. Accountability
 - c. Teamwork
 - d. Innovation
 - e. Fiscal Responsibility
 - f. Service

4. If yes, what actions are you going to continue? If no, what modifications are you going to make in order to meet the expectations of your position?

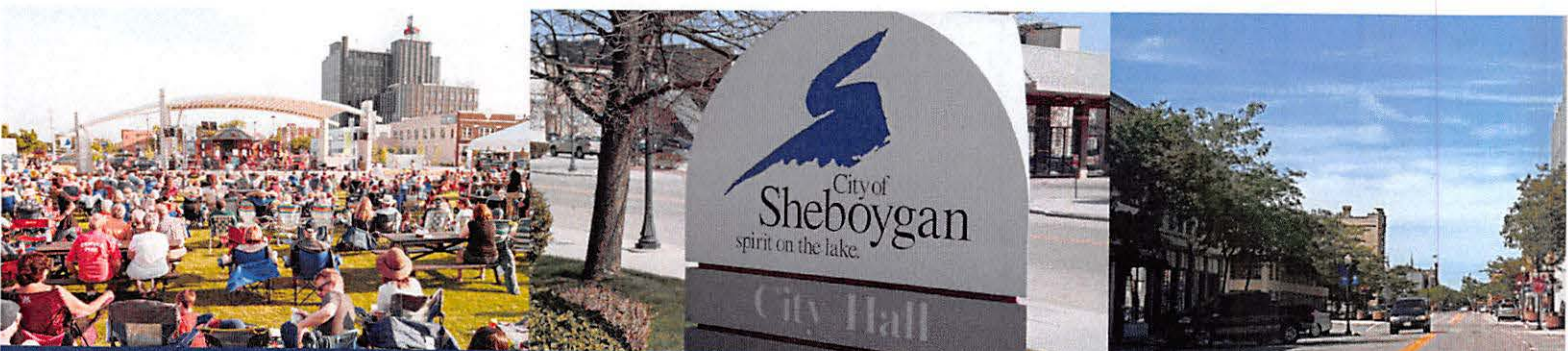

For more about Sheboygan, visit www.sheboyganwi.gov

~~X~~

Gen. Ord. No. _____ - 18 - 19. By Alderperson Phillips. March 4, 2019.

AN ORDINANCE granting Prohibition Bistro, its successors and assigns, the privilege of encroaching upon described portions of Lot 1 Promenade, South Pier located at 668 South Pier Drive in the City of Sheboygan for the purpose of expanding the outdoor patio area.

THE COMMON COUNCIL OF THE CITY OF SHEBOYGAN DO ORDAIN AS FOLLOWS:

Section 1. Subject to the terms and conditions contained herein, Prohibition Bistro, its successors and assigns, is hereby granted the privilege of encroaching upon described portions of Lot 1 Promenade, South Pier, located at 668 South Pier Drive as follows:

Part of Lot 1 Promenade, South Pier, located in Government Lot 1 of Section 26, T15N-R23E, City of Sheboygan, Sheboygan County, Wisconsin lying west of and adjacent to that part of Lot 2, South Pier as described in "Correction Instrument Consolidated and Restated Prohibition Bistro Ground Lease" as Document Number 1971182 described as: Commencing at the Northwest corner of Lot 2, South Pier, said point being the point of beginning; thence along the west line of said Lot 2, S22°48'04"W 59.90 feet; thence N69°23'27"W 15.88 feet; thence N23°44'57"E 56.40 feet; thence S82°35'49"E 15.49 feet to the point of beginning. SAID AREA CONTAINS 894 SQ. FT. (0.021 ACRE)

for the purpose of expanding the outdoor patio area, in accordance with the sketch attached hereto and made a part hereof.

Section 2. The privilege as granted above is granted only on the condition that by the acceptance of the privilege, the said Prohibition Bistro, its successors and assigns:

a. Shall become primarily responsible and liable for all and any damage to persons or property caused by and arising from the grant and exercise of such privilege.

b. Shall remove the encroachment allowed herein within ten (10) days after notice so to remove given by the State of Wisconsin or the City of Sheboygan; in the event of the failure so to remove, the said Prohibition Bistro, its successors and assigns: shall pay the costs of removal by the State of Wisconsin or the City of Sheboygan, waiving all claim or claims for damages resulting from such removal, whether the removal is done by the said Prohibition Bistro, its successors and assigns, or by the State of Wisconsin or by the City of Sheboygan.

City Plan

c. Shall pay such compensation to the City of Sheboygan for the grant of this privilege as may be determined by a board consisting of the Mayor, the Director of Public Works and the City Attorney; the compensation shall be paid into the General Fund.

d. Shall make such construction and/or alterations and maintain the same subject to the approval of the City Building Inspector and Director of Public Works, and shall waive the right to contest in any manner the validity of this ordinance or the amount of compensation charged.

Section 3. The provisions of §66.0425(1) thru (5) of the Wisconsin Statutes are incorporated herein by reference to all intents and purposes as if set out fully.

Section 4. The City Clerk is authorized and directed to record a certified copy of this ordinance in the office of the Register of Deeds for Sheboygan County, Wisconsin, the costs thereof to be charged to the General Fund.

Section 5. This ordinance shall take effect and be in full force from and after its passage and publication and upon payment of the consideration to be determined hereunder, provided, however, that in the event of failure to exercise the privilege herein granted and the payment of such consideration within six (6) months from the effective date hereof, then and in that event such privilege shall be rendered null and void.

I HEREBY CERTIFY that the foregoing Ordinance was duly passed by the Common Council of the City of Sheboygan, Wisconsin, on the _____ day of _____, 20____.

Dated _____ 20____. _____, City Clerk

Approved _____ 20____. _____, Mayor

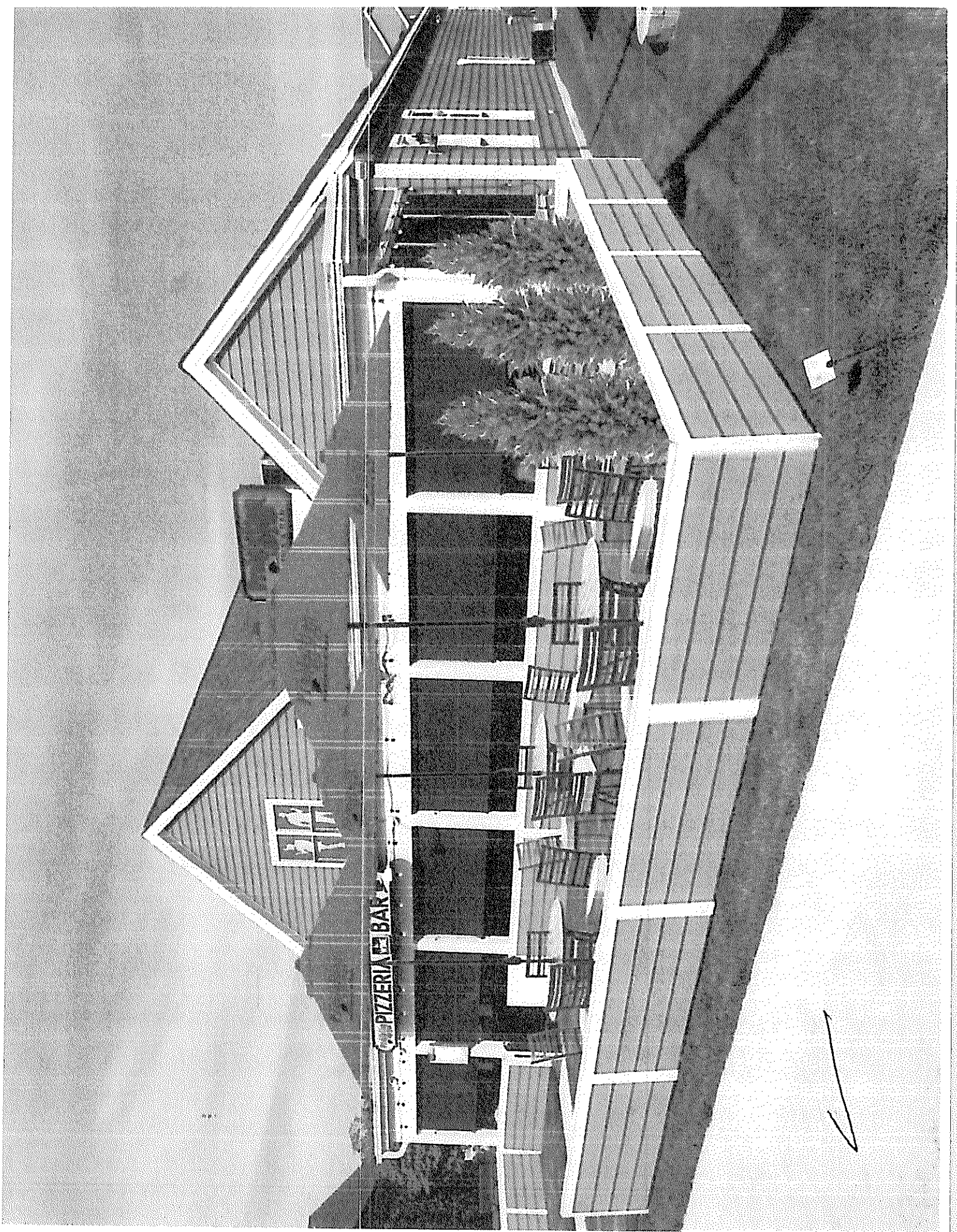

Encroachment Request
for
Prohibition Bistro 668 LLC

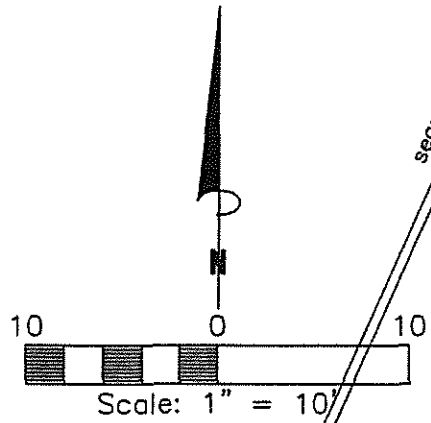

- = 1" iron pipe found
- ▲ = Large dia. nail found

Vertical Datum=City of Sheboygan
(Benchmark: Top of hydrant at
Pier Dr & Fisherman's Row, Elev 8.66)

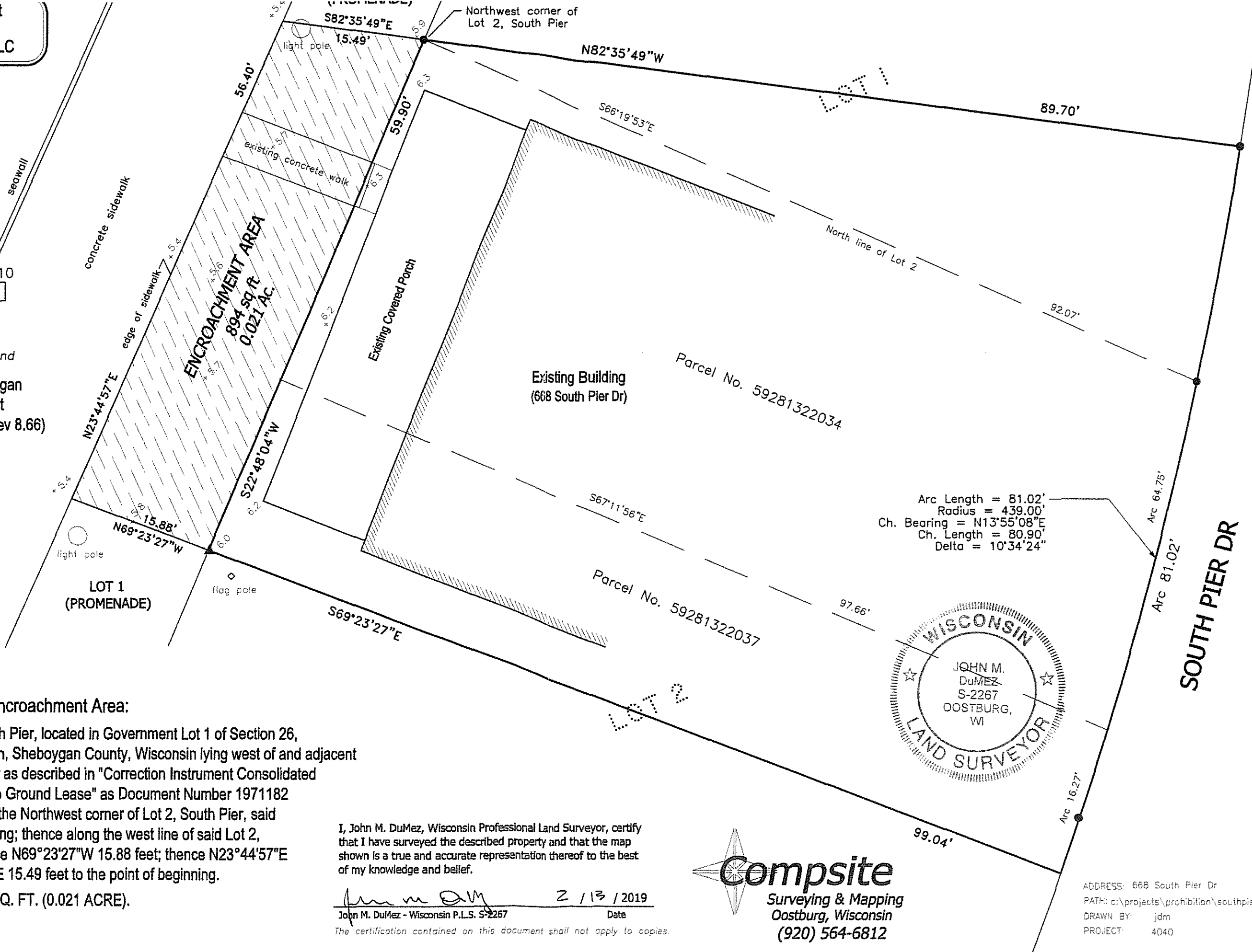

Description of Proposed Encroachment Area:

Part of Lot 1 Promenade, South Pier, located in Government Lot 1 of Section 26, T15N-R23E, City of Sheboygan, Sheboygan County, Wisconsin lying west of and adjacent to that part of Lot 2, South Pier as described in "Correction Instrument Consolidated and Restated Prohibition Bistro Ground Lease" as Document Number 1971182 described as: Commencing at the Northwest corner of Lot 2, South Pier, said point being the point of beginning; thence along the west line of said Lot 2, S22°48'04"W 59.90 feet; thence N69°23'27"W 15.88 feet; thence N23°44'57"E 56.40 feet; thence S82°35'49"E 15.49 feet to the point of beginning.

SAID AREA CONTAINS 894 SQ. FT. (0.021 ACRE).

I, John M. DuMez, Wisconsin Professional Land Surveyor, certify that I have surveyed the described property and that the map shown is a true and accurate representation thereof to the best of my knowledge and belief.

John M. DuMez 2/13/2019
John M. DuMez - Wisconsin P.L.S. S-2267 Date

The certification contained on this document shall not apply to copies.

Compsite
Surveying & Mapping
Oostburg, Wisconsin
(920) 564-6812

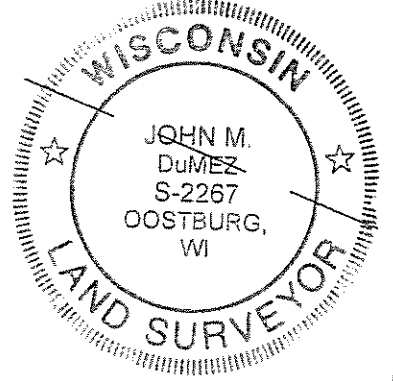

ADDRESS: 666 South Pier Dr
PATH: c:\projects\prohibition\southpier\dwg\
DRAWN BY: jdm
PROJECT: 4040

II

R. O. No. 226 - 18 - 19. By CITY CLERK. March 4, 2019.

Submitting various license applications for the period ending June 30, 2019, December 31, 2019 and June 30, 2020.

City Clerk

CHANGE OF PREMISE (PERMANENT)

<u>No.</u>	<u>Name</u>	<u>Address</u>
2949	Harrys Prohibition Bistro	668 South Pier Drive - Alcohol will be served within the new constructed walls/barriers patio on the west side of Prohibition Bistro along the boardwalk. All alcohol will be stored inside the building and no alcohol will be left outside after business hours.

BEVERAGE OPERATOR'S LICENSE (NEW) (June 30, 2020)

<u>No.</u>	<u>Name</u>	<u>Address</u>
2616	Birenbaum, Jenipher A.	1930 N. 7 th Street
2619	Campbell, Rebecca	1504 Illinois Avenue
0727	Fetterer, Aina L.	4407 Primrose Court #P208
2622	Guy, Le'Shay L.	4918 Windward Court Apt. 16
2613	Lietzau, Julie M.	8512 Pigeon Lake Road, Valders
2403	Myers, Makai C.	1207 N. 12 th Street
2617	Olvera, Juan F.	718 Superior Avenue
2614	Raml, Jennifer L.	2605 N. 9 th Street
2615	Rutherford, Amy L.	2220 S. 42 nd Street, Manitowoc
2112	Schreiner, Kurt	1231 N. 8 th Street
9913	Steinberg, Rebecca M.	1811 N. 3 rd Street

TAXICAB DRIVERS LICENSE (NEW) (December 31, 2019)

<u>No.</u>	<u>Name</u>	<u>Address</u>
2428	Flunker, Angela S.	3616 Larkspar Way
0677	Perez-Velo, Erik F.	1623 Saemann Avenue
7238	Schaal, Kelli J.	1505 St. Clair Avenue

LHPS

Massage License (NEW) (December 31, 2019)

No. Name

Address

2044 Groove Salon

1227 N. 8th Street