

*****ATTACHMENTS*****

CITY OF SHEBOYGAN**LICENSING, HEARINGS, AND PUBLIC SAFETY COMMITTEE MINUTES****APRIL 3, 2019**

MEMBERS PRESENT: Chair Alderperson Mary Lynne Donohue, Vice Chair Alderperson Ryan Sorenson, Alderperson Trey Mitchell, Alderperson Ron Rindfleisch

STAFF/OFFICIALS PRESENT: City Attorney Charles C. Adams, Alderperson Betty Ackley, Legal Assistant Marie Stefancin

OTHERS PRESENT: None

1. OPENING OF MEETING

1.1 Roll Call

1.2 Call to Order

Chair Alderperson Mary Lynne Donohue called the meeting to order at 5:31 p.m.

1.3 Pledge of Allegiance

The Pledge of Allegiance was recited.

1.4 Introduction of Committee members, staff and guests

2. MINUTES

2.1 Approval of Minutes - March 13, 2019

Motion by Alderperson Sorenson, seconded by Alderperson Mitchell, to approve the minutes of the previous meeting held March 13, 2019. Motion carried 4-0.

3. ITEMS FOR DISCUSSION AND POSSIBLE ACTION

3.1 R.O. No. 235-18-19 (DIRECT REFERRAL) Submitting various license applications for the period ending December 31, 2019

Motion by Alderperson Sorenson, seconded by Alderperson Mitchell, to grant all license applications for individuals and entities listed on the above-referenced R.O. Motion carried 4-0.

3.2 R.O. No. 234-18-19 (3-18-19) Submitting various license applications for the period ending December 31, 2019, April 14, 2020 and June 30, 2020

Motion by Alderperson Sorenson, seconded by Alderperson Mitchell, to hold Bev. Op. Lic. App. No. 2628 (Mang Yang) for a hearing on possible denial of her license application. Motion carried 4-0.

Motion by Alderperson Sorenson, seconded by Alderperson Mitchell, to grant the remainder of the license applications for individuals and entities listed on the above-referenced R.O. Motion carried 4-0.

4. NEXT MEETING DATE

4.1 Next meeting date will be April 10, 2019

The next committee meeting is scheduled to be held on April 10, 2019 at 4:00 p.m. in the Rocca Meeting Room at the Mead Public Library, 710 North 8th Street, Sheboygan.

5. ADJOURN

5.1 Motion to adjourn

Motion by Alderperson Rindfleisch, seconded by Alderperson Sorenson, to adjourn at 5:33 p.m.

Motion carried 4-0.

CITY OF SHEBOYGAN

**REQUEST FOR LICENSING, HEARINGS AND PUBLIC SAFETY COMMITTEE
CONSIDERATION**

ITEM DESCRIPTION: Capital Improvement Projects (CIP) for the years 2020-2024 for the Police Department.

REPORT PREPARED BY: Christopher Domagalski, Chief of Police

REPORT DATE: April 4, 2019

MEETING DATE: April 10, 2019

FISCAL SUMMARY:

Budget Line Item: N/A
Budget Summary: N/A
Budgeted Expenditure: N/A
Budgeted Revenue: N/A

STATUTORY REFERENCE:

Wisconsin Statutes: N/A
Municipal Code: N/A

BACKGROUND / ANALYSIS: Five year CIP plan for the Police Department.

STAFF COMMENTS: The Police Department CIP plan for 2020-2024 includes the following projects for 2020.

Vehicle Replacement - \$252,300. The plan for 2020 follows the department replacement cycle and includes the replacement of four marked squads and one unmarked squad. One marked K-9 vehicle is also included.

Parking Lot improvements - \$100,000. The parking for employees at the Police facility is currently not adequate. In 2018 the City acquired a parcel of land directly east of the police facility that was previously used by the Sheboygan County Highway Department. These funds would allow for site improvements to provide use of the parcel for additional parking and impound storage. Future plan requests would include funding for improvements to relocate evidence storage operations from the Public Works lot to this site.

HVAC Controls - \$195,000. This proposal is for the replacement of the current Police Facility HVAC Control System and secure Entry Point system. The systems were installed in 2008 and are failing. The plan calls for placing the controls on the city's master central control system.

Police Range Remediation - \$45,000. This proposal is to remediate and restore the berms at the police range to maintain environmental compliance and maintain the safety of the range.

ACTION REQUESTED: For discussion only.

ATTACHMENTS:

- I. Police CIP Plan

5 YEAR CAPITAL IMPROVEMENTS PROGRAM

| | 2020 <u>Requested</u> | 2021 <u>Requested</u> | 2022 <u>Requested</u> | 2023 <u>Requested</u> | 2024 <u>Requested</u> | <u>Total</u> |
|--|--------------------------|--------------------------|--------------------------|--------------------------|--------------------------|--------------------|
| <u>REVENUES</u> | | | | | | |
| Property Tax Levy: Capital Project Fund | | | | | | |
| Police | \$251,300 | \$254,000 | \$235,000 | \$190,000 | \$150,000 | \$1,080,300 |
| Street Improvement and Sidewalks | \$0 | \$0 | \$0 | \$0 | \$0 | \$0 |
| General Government Projects | \$0 | \$0 | \$0 | \$0 | \$0 | \$0 |
| Fire | \$0 | \$0 | \$0 | \$0 | \$0 | \$0 |
| Park, Forestry and Open Space Fund | \$0 | \$0 | \$0 | \$0 | \$0 | \$0 |
| Park Impact Fee Fund | \$0 | \$0 | \$0 | \$0 | \$0 | \$0 |
| Vehicle / Land Sales | \$46,000 | \$28,000 | \$52,000 | \$44,000 | \$40,000 | \$210,000 |
| County / State / Federal Grants | \$0 | \$0 | \$0 | \$0 | \$0 | \$0 |
| Other Municipality Contributions | \$0 | \$0 | \$0 | \$0 | \$0 | \$0 |
| G. O. Borrowed Funds | \$295,000 | \$0 | \$0 | \$0 | \$0 | \$295,000 |
| Other Borrowed Funds | \$0 | \$0 | \$0 | \$0 | \$0 | \$0 |
| Donations | \$0 | \$0 | \$0 | \$0 | \$0 | \$0 |
| User Fees | \$0 | \$0 | \$0 | \$0 | \$0 | \$0 |
| Special Assessment | \$0 | \$0 | \$0 | \$0 | \$0 | \$0 |
| Vehicle Registration Fee | \$0 | \$0 | \$0 | \$0 | \$0 | \$0 |
| Other/CDBG | \$0 | \$0 | \$0 | \$0 | \$0 | \$0 |
| Fund Balance | \$0 | \$0 | \$0 | \$0 | \$0 | \$0 |
| TOTAL REVENUE | \$592,300 | \$282,000 | \$287,000 | \$234,000 | \$190,000 | \$1,585,300 |
| Police | | | | | | |
| Marked K-9 Vehicle | \$45,300 | \$0 | \$0 | \$0 | \$0 | \$45,300 |
| Unmarked Vehicle | \$43,000 | \$0 | \$0 | \$0 | \$0 | \$43,000 |
| Marked Vehicles - Sport Utility Vehicles (4) | \$164,000 | \$0 | \$0 | \$0 | \$0 | \$164,000 |
| Parking Lot - Impound Area Improvements | \$100,000 | \$0 | \$0 | \$0 | \$0 | \$100,000 |
| HVAC Control - Secure Entry Systems | \$195,000 | \$0 | \$0 | \$0 | \$0 | \$195,000 |
| Police Range Remediation | \$45,000 | \$0 | \$0 | \$0 | \$0 | \$45,000 |
| Squad computers | \$0 | \$66,000 | \$0 | \$0 | \$0 | \$66,000 |
| Unmarked Vehicles (2) | \$0 | \$86,000 | \$0 | \$0 | \$0 | \$86,000 |
| Unmarked Vehicle - Sport Utility Vehicle | \$0 | \$43,000 | \$0 | \$0 | \$0 | \$43,000 |
| Marked Vehicle - Sport Utility Vehicle | \$0 | \$43,000 | \$0 | \$0 | \$0 | \$43,000 |
| Marked K-9 Vehicle | \$0 | \$44,000 | \$0 | \$0 | \$0 | \$44,000 |
| Facility Boiler Replacement | \$0 | \$0 | \$18,000 | \$0 | \$0 | \$18,000 |
| Marked Vehicle - Sport Utility Vehicles (5) | \$0 | \$0 | \$225,000 | \$0 | \$0 | \$225,000 |
| Unmarked Vehicle | \$0 | \$0 | \$44,000 | \$0 | \$0 | \$44,000 |
| Patrol Wagon | \$0 | \$0 | \$0 | \$50,000 | \$0 | \$50,000 |
| Marked Vehicles - Sport Utility Vehicles (4) | \$0 | \$0 | \$0 | \$184,000 | \$0 | \$184,000 |
| Marked Vehicles - Sport Utility Vehicles (4) | \$0 | \$0 | \$0 | \$0 | \$190,000 | \$190,000 |
| Total - Police | \$592,300 | \$282,000 | \$287,000 | \$234,000 | \$190,000 | \$1,585,300 |

CITY OF SHEBOYGAN

REQUEST FOR LICENSING, HEARINGS, AND PUBLIC SAFETY COMMITTEE CONSIDERATION

ITEM DESCRIPTION: Discussion and possible action regarding establishing public safety training center

REPORT PREPARED BY: Chuck Butler, Assistant Fire Chief

REPORT DATE: April 4, 2019

MEETING DATE: April 10, 2019

FISCAL SUMMARY:

Budget Line Item: N/A
Budget Summary: N/A
Budgeted Expenditure: N/A
Budgeted Revenue: N/A

STATUTORY REFERENCE:

Wisconsin Statutes: N/A
Municipal Code: N/A

BACKGROUND / ANALYSIS:

This is a brief communication regarding efforts toward a potential public safety training facility.

STAFF COMMENTS:

The Fire Department has a long-standing need of a facility to safely and effectively train firefighters in a designated location with certain types of capabilities and props. The department would like to discuss the possibility of a public/private initiative to plan and fund this program through a fund raising effort in the community.

The vision is that this would be a shared public safety facility between community organizations and businesses as well as fire and police departments.

ACTION REQUESTED:

For informational purposes only.

ATTACHMENTS:

None

CITY OF SHEBOYGAN

REQUEST FOR LICENSING, HEARINGS, AND PUBLIC SAFETY COMMITTEE CONSIDERATION

ITEM DESCRIPTION: Capital Improvements Projects (CIP) for the years 2020 – 2024 for the Fire Department.

REPORT PREPARED BY: Chuck Butler, Assistant Fire Chief

REPORT DATE: April 4, 2019

MEETING DATE: April 10, 2019

FISCAL SUMMARY:

STATUTORY REFERENCE:

Budget Line Item: N/A
Budget Summary: N/A
Budgeted Expenditure: N/A
Budgeted Revenue: N/A

Wisconsin Statutes: N/A
Municipal Code: N/A

BACKGROUND / ANALYSIS:

Annual Capital Improvements Program (CIP) for the Fire Department

STAFF COMMENTS:

The following is a summary of the 2020 requests for the Capital Improvements Commission on behalf of the Fire Department.

The CIP for the Fire Department over the next five years commencing 2020 is primarily focused in two areas. 1) Renovation projects for fire stations based on third party reviews of building conditions and 2) Scheduled vehicle replacements. Station #2 is scheduled to have significant work done in 2020, while station #3 is slated to begin a four-phase renovation beginning in 2021. A scheduled replacement of an aging engine is scheduled for 2020, and in 2022, the first of three ambulances is scheduled to be replaced. To provide a more balanced capital expenditure, ambulance replacements are to be spaced over a three-year period.

The item listed for a training facility in 2021 is tentative pending a potential public/private partnership initiative and would be funded largely through grants.

ACTION REQUESTED:

For informational purposes only.

ATTACHMENTS:

- I. Fire Department CIP Program 2020 - 2024

5 YEAR CAPITAL IMPROVEMENTS PROGRAM

| | 2020 | 2021 | 2022 | 2023 | 2024 | Total |
|---|------------------|------------------|------------------|------------------|------------------|--------------------|
| | <u>Requested</u> | <u>Requested</u> | <u>Requested</u> | <u>Requested</u> | <u>Requested</u> | <u>Total</u> |
| REVENUES | | | | | | |
| Property Tax Levy: Capital Project Fund | | | | | | |
| Police | \$0 | \$0 | \$0 | \$0 | \$0 | \$0 |
| Street Improvement and Sidewalks | \$0 | \$0 | \$0 | \$0 | \$0 | \$0 |
| General Government Projects | \$0 | \$0 | \$0 | \$0 | \$0 | \$0 |
| Fire | \$0 | \$0 | \$0 | \$0 | \$0 | \$0 |
| Park, Forestry and Open Space Fund | \$0 | \$0 | \$0 | \$0 | \$0 | \$0 |
| Park Impact Fee Fund | \$0 | \$0 | \$0 | \$0 | \$0 | \$0 |
| Vehicle / Land Sales | \$20,000 | \$0 | \$20,000 | \$20,000 | \$20,000 | \$80,000 |
| County / State / Federal Grants | \$0 | \$0 | \$0 | \$0 | \$0 | \$0 |
| Other Municipality Contributions | \$0 | \$0 | \$0 | \$0 | \$0 | \$0 |
| G. O. Borrowed Funds | \$917,644 | \$140,000 | \$566,500 | \$631,000 | \$442,500 | \$2,697,644 |
| Other Borrowed Funds | \$0 | \$0 | \$0 | \$0 | \$0 | \$0 |
| Donations | \$0 | \$835,000 | \$0 | \$0 | \$0 | \$835,000 |
| User Fees | \$0 | \$0 | \$0 | \$0 | \$0 | \$0 |
| Special Assessment | \$0 | \$0 | \$0 | \$0 | \$0 | \$0 |
| Vehicle Registration Fee | \$0 | \$0 | \$0 | \$0 | \$0 | \$0 |
| Other/CDBG | \$0 | \$0 | \$0 | \$0 | \$0 | \$0 |
| Fund Balance | \$0 | \$0 | \$0 | \$0 | \$0 | \$0 |
| TOTAL REVENUE | \$937,644 | \$975,000 | \$586,500 | \$651,000 | \$462,500 | \$3,612,644 |

Fire

| | | | | | | |
|----------------------------------|------------------|------------------|------------------|------------------|------------------|--------------------|
| Engine | \$620,000 | \$0 | \$0 | \$0 | \$0 | \$620,000 |
| Station Two | \$317,644 | \$0 | \$0 | \$0 | \$0 | \$317,644 |
| Station Three - Phase 1 | \$0 | \$140,000 | \$0 | \$0 | \$0 | \$140,000 |
| Training Facility | \$0 | \$835,000 | \$0 | \$0 | \$0 | \$835,000 |
| Station Three - Phase 2 | \$0 | \$0 | \$250,500 | \$0 | \$0 | \$250,500 |
| Ambulance | \$0 | \$0 | \$336,000 | \$0 | \$0 | \$336,000 |
| Station Three - Phase 3 | \$0 | \$0 | \$0 | \$301,000 | \$0 | \$301,000 |
| Ambulance | \$0 | \$0 | \$0 | \$350,000 | \$0 | \$350,000 |
| Station Three - Phase 4 | \$0 | \$0 | \$0 | \$0 | \$102,000 | \$102,000 |
| Ambulance | \$0 | \$0 | \$0 | \$0 | \$360,500 | \$360,500 |
| Total - Fire & Rescue | \$937,644 | \$975,000 | \$586,500 | \$651,000 | \$462,500 | \$3,612,644 |

CITY OF SHEBOYGAN

REQUEST FOR LICENSING, HEARINGS, AND PUBLIC SAFETY COMMITTEE CONSIDERATION

ITEM DESCRIPTION: R.O. by the Fire Department submitting the 2018 Annual Report

REPORT PREPARED BY: Chuck Butler, Assistant Fire Chief

REPORT DATE: April 4, 2019

MEETING DATE: April 10, 2019

FISCAL SUMMARY:

STATUTORY REFERENCE:

Budget Line Item: N/A
Budget Summary: N/A
Budgeted Expenditure: N/A
Budgeted Revenue: N/A

Wisconsin Statutes: N/A
Municipal Code: N/A

BACKGROUND / ANALYSIS:

This is the submission and brief recap of the activities for the Fire Department in 2018.

STAFF COMMENTS:

The Fire Department will present the annual report to the LHPS committee and discuss the highlights of 2018 activities of the Fire Department.

ACTION REQUESTED:

Motion to recommend to Council to Approve the Report of Officer No. 233-18-19.

ATTACHMENTS:

R.O. No. 233-18-19 (3-18-19)

II

3.5

R. O. No. 233 - 18 - 19. By ASSISTANT FIRE CHIEF BUTLER. March 18, 2019.

Submitting the Annual Report for City of Sheboygan Fire Department for the year 2018.

ASSISTANT FIRE CHIEF CHARLES BUTLER

LHPS

2018

Annual Report



City of Sheboygan
Fire Department



Sheboygan Fire Department Annual Report | 2018



Thank you citizens, council and city leaders for supporting your Sheboygan Fire Department!

2018 was a great year for the department and the City of Sheboygan. We completed the year with no fire deaths and we improved our stations, apparatus and equipment to meet immediate and future needs. These improvements enhance services to our citizens on each and every medical or fire response.

We are proud of our 2018 accomplishments:

- Exceeded our 2017 ambulance revenue goal of \$1,200,000
- Completed our ambulance refurbishment program, saving \$240,000
- Won a federal health and wellness grant for \$98,000
- Received a State of Wisconsin award of \$87,000 for the successful completion of the 2016 fire inspection program
- Earned the highest satisfaction rating by citizens for fire and emergency medical service
- Successfully implemented the new emergency medical dispatch procedure
- Renovated training room with enhanced technology and a new department-wide teleconference system
- Initiated remodeling and repairs to our 112 year-old Fire Station 1
- Completed all architectural and engineering work for Station 2
- Added new electric extrication equipment
- Purchased two fire suppression tools with \$1,000 Kwik Trip grant
- Implemented new telecommunication system

Our mission is to provide quality professional services to those who live, work, invest, or visit our community. We accomplish this through the talent and commitment of the members of the Sheboygan Fire Department along with the leadership and support of our city leaders and the common council.

Yours in fire safety and prevention,

A handwritten signature in blue ink that reads "Mike T. Romas". The signature is written in a cursive style.

Mike Romas

Fire Chief

City of Sheboygan



Department Mission

The Sheboygan Fire Department is dedicated to serving all who live, visit, work and invest in the City of Sheboygan through excellence in fire protection, rescue, emergency and non-emergency medical services, code enforcement, and education, and at the highest professional level in a compassionate, ethical, and cost effective manner.

Courage * Honor * Integrity



Sheboygan Fire Department Annual Report | 2018

Sheboygan Fire Department Management and Administrative Staff



FIRE CHIEF – MICHAEL T. ROMAS
CHIEF OF THE DEPARTMENT



ASSISTANT CHIEF – VERNON KOCH



ASSISTANT CHIEF – CHARLES BUTLER



BATTALION CHIEF – PAT NICOLAUS
A SHIFT
EMS



BATTALION CHIEF – DEAN KLEIN
B SHIFT
SUPPORT SERVICES



BATTALION CHIEF – KEITH RISSE
C SHIFT
TRAINING



CONFIDENTIAL SECRETARY
LISA HORN



ADMINISTRATIVE ASSISTANT
JENNIFER ALBRIGHT



BATTALION CHIEF
ROBERT KOCMOUD

Sheboygan Fire Department Annual Report | 2018

| Detailed Breakdown by Incident Type | | |
|--|-------------|------------|
| INCIDENT TYPE | # INCIDENTS | % of TOTAL |
| 111 - Building fire | 48 | 0.89% |
| 112 - Fires in structure other than in a building | 1 | 0.02% |
| 113 - Cooking fire, confined to container | 5 | 0.09% |
| 116 - Fuel burner/boiler malfunction, fire confined | 1 | 0.02% |
| 118 - Trash or rubbish fire, contained | 3 | 0.06% |
| 121 - Fire in mobile home used as fixed residence | 1 | 0.02% |
| 130 - Mobile property (vehicle) fire, other | 1 | 0.02% |
| 131 - Passenger vehicle fire | 12 | 0.22% |
| 132 - Road freight or transport vehicle fire | 1 | 0.02% |
| 134 - Water vehicle fire | 1 | 0.02% |
| 135 - Aircraft fire | 1 | 0.02% |
| 138 - Off-road vehicle or heavy equipment fire | 1 | 0.02% |
| 141 - Forest, woods or wildland fire | 1 | 0.02% |
| 142 - Brush or brush-and-grass mixture fire | 1 | 0.02% |
| 151 - Outside rubbish, trash or waste fire | 8 | 0.15% |
| 154 - Dumpster or other outside trash receptacle fire | 5 | 0.09% |
| 160 - Special outside fire, other | 1 | 0.02% |
| 162 - Outside equipment fire | 2 | 0.04% |
| 251 - Excessive heat, scorch burns with no ignition | 36 | 0.67% |
| 300 - Rescue, EMS incident, other | 70 | 1.30% |
| 311 - Medical assist, assist EMS crew | 184 | 3.43% |
| 320 - Emergency medical service, other | 10 | 0.19% |
| 321 - EMS call, excluding vehicle accident with injury | 3769 | 70.20% |
| 322 - Motor vehicle accident with injuries | 117 | 2.18% |
| 323 - Motor vehicle/pedestrian accident (MV Ped) | 9 | 0.17% |
| 324 - Motor vehicle accident with no injuries. | 16 | 0.30% |
| 331 - Lock-in (if lock out , use 511) | 15 | 0.28% |
| 342 - Search for person in water | 1 | 0.02% |
| 351 - Extrication of victim(s) from building/structure | 1 | 0.02% |
| 352 - Extrication of victim(s) from vehicle | 3 | 0.06% |
| 353 - Removal of victim(s) from stalled elevator | 5 | 0.09% |
| 361 - Swimming/recreational water areas rescue | 2 | 0.04% |
| 364 - Surf rescue | 1 | 0.02% |
| 381 - Rescue or EMS standby | 17 | 0.32% |
| 411 - Gasoline or other flammable liquid spill | 11 | 0.20% |
| 412 - Gas leak (natural gas or LPG) | 26 | 0.48% |
| 413 - Oil or other combustible liquid spill | 14 | 0.26% |
| 421 - Chemical hazard (no spill or leak) | 1 | 0.02% |
| 422 - Chemical spill or leak | 31 | 0.58% |
| 424 - Carbon monoxide incident | 17 | 0.32% |
| 440 - Electrical wiring/equipment problem, other | 1 | 0.02% |
| 441 - Heat from short circuit (wiring), defective/worn | 4 | 0.07% |
| 442 - Overheated motor | 4 | 0.07% |
| 443 - Breakdown of light ballast | 4 | 0.07% |
| 444 - Power line down | 18 | 0.34% |

Sheboygan Fire Department Annual Report | 2018

| | | |
|--|-------------|----------------|
| 445 - Arcing, shorted electrical equipment | 17 | 0.32% |
| 451 - Biological hazard, confirmed or suspected | 1 | 0.02% |
| 463 - Vehicle accident, general cleanup | 2 | 0.04% |
| 500 - Service Call, other | 3 | 0.06% |
| 510 - Person in distress, other | 1 | 0.02% |
| 511 - Lock-out | 51 | 0.95% |
| 512 - Ring or jewelry removal | 2 | 0.04% |
| 520 - Water problem, other | 3 | 0.06% |
| 521 - Water evacuation | 1 | 0.02% |
| 522 - Water or steam leak | 8 | 0.15% |
| 531 - Smoke or odor removal | 16 | 0.30% |
| 542 - Animal rescue | 14 | 0.26% |
| 551 - Assist police or other governmental agency | 33 | 0.61% |
| 552 - Police matter | 4 | 0.07% |
| 553 - Public service | 94 | 1.75% |
| 554 - Assist invalid | 110 | 2.05% |
| 555 - Defective elevator, no occupants | 1 | 0.02% |
| 561 - Unauthorized burning | 63 | 1.17% |
| 571 - Cover assignment, standby, moveup | 1 | 0.02% |
| 600 - Good intent call, other | 39 | 0.73% |
| 611 - Dispatched & cancelled en route | 56 | 1.04% |
| 621 - Wrong location | 1 | 0.02% |
| 622 - No incident found on arrival at dispatch address | 31 | 0.58% |
| 631 - Authorized controlled burning | 14 | 0.26% |
| 651 - Smoke scare, odor of smoke | 13 | 0.24% |
| 652 - Steam, vapor, fog or dust thought to be smoke | 6 | 0.11% |
| 653 - Smoke from barbecue, tar kettle | 2 | 0.04% |
| 661 - EMS call, party transported by non-fire agency | 6 | 0.11% |
| 671 - HazMat release investigation w/no HazMat | 25 | 0.47% |
| 700 - False alarm or false call, other | 1 | 0.02% |
| 710 - Malicious, mischievous false call, other | 2 | 0.04% |
| 714 - Central station, malicious false alarm | 10 | 0.19% |
| 715 - Local alarm system, malicious false alarm | 11 | 0.20% |
| 730 - System malfunction, other | 1 | 0.02% |
| 731 - Sprinkler activation due to malfunction | 12 | 0.22% |
| 733 - Smoke detector activation due to malfunction | 39 | 0.73% |
| 734 - Heat detector activation due to malfunction | 2 | 0.04% |
| 735 - Alarm system sounded due to malfunction | 44 | 0.82% |
| 736 - CO detector activation due to malfunction | 14 | 0.26% |
| 740 - Unintentional transmission of alarm, other | 2 | 0.04% |
| 741 - Sprinkler activation, no fire - unintentional | 5 | 0.09% |
| 742 - Extinguishing system activation | 2 | 0.04% |
| 743 - Smoke detector activation, no fire - unintentional | 53 | 0.99% |
| 744 - Detector activation, no fire - unintentional | 9 | 0.17% |
| 745 - Alarm system activation, no fire - unintentional | 52 | 0.97% |
| 746 - Carbon monoxide detector activation, no CO | 8 | 0.15% |
| 911 - Citizen complaint | 3 | 0.06% |
| TOTAL INCIDENTS: | 5369 | 100.00% |

SHEBOYGAN FIRE DEPARTMENT
TABLE OF ORGANIZATION

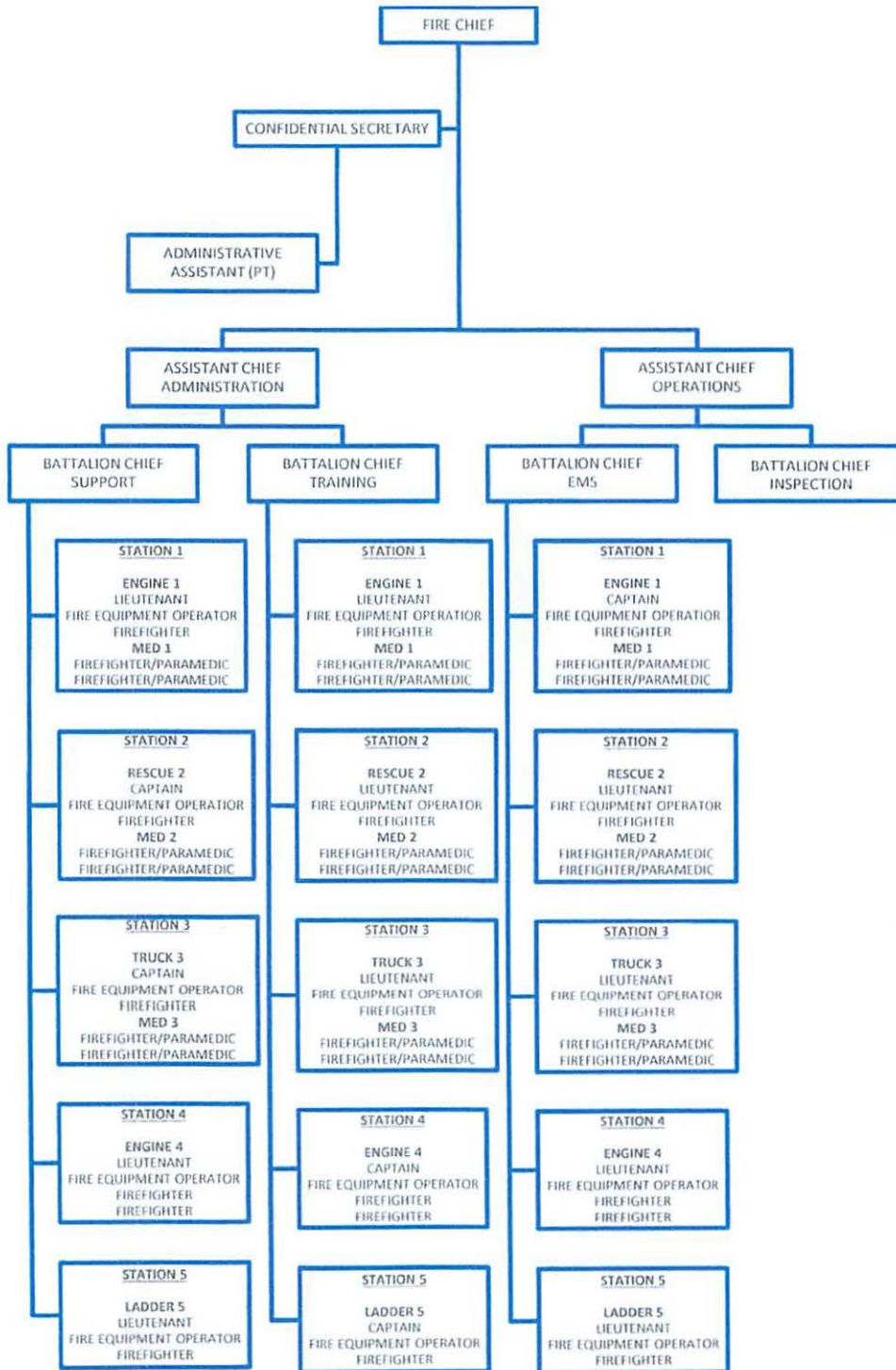

Sheboygan Fire Department Annual Report | 2018



Fire Station #1
833 New York Avenue
Engine 1
Med 1

Fire Station #2
2413 South 18th Street
Rescue 2
Med 2
Trench Rescue Trailer



Fire Station #3
1326 North 25th Street – Department Headquarters
Engine 3
Med 3
Battalion Chief Car

Fire Station #4
2622 North 15th Street
Ladder 4
Engine 6 (Reserve Engine)
Med 6 (Reserve Ambulance)



Fire Station #5
4504 South 18th Street
Ladder 5
Engine 7 (Reserve Engine)

Services Provided by the Sheboygan Fire Department

| | |
|---------------------------------------|-------------------------------------|
| Fire Suppression and Rescue | Code Enforcement |
| Rope Rescue | Building Plan Review |
| Excavation Rescue | Fire Safety Training for Businesses |
| Confined Space Rescue | Medical Transports |
| Water/Ice Rescue | Public Service/Assistance |
| Automobile and Industrial Extrication | Hazardous Materials Response |
| Emergency Management | School Fire Safety Education |
| Advanced Life Support Response | Special Event Standby |
| Fire Safety Building Inspections | Fall Prevention Referrals |
| Smoke Alarm Installations | |

Equipment, Facilities, and Vehicles Status Update

Equipment

- All cardiac monitors received preventative maintenance.
- All patient moving equipment, stair chairs and power cots received preventative maintenance.
- As part of a cancer mitigation program, the department continues to add additional sets of 10 new sets of personal protective gear so that each member has a second set while theirs is being cleaned between fires.
- Also as part of the cancer mitigation program a new extraction machine and a drying cabinet has been purchased to better remove contaminants from the personal fire gear. This process lessens the exposure to carcinogens in the by products of fires. Each apparatus also carries personal decon kits to be able to clean contaminants from skin as soon as possible after being exposed during fires.
- All ladders and pumps were tested to industry standards.
- All department fire hoses were inspected and pressure tested.

Apparatus

- In May of 2018 the department took delivery of a new Pierce Pumper now serving as E4.
- Delivery of a Pierce aerial ladder occurred in 2018 and will be placed into service in 2019 as Truck 3.

Buildings

- Work continues on Station #1 as part of a comprehensive maintenance and upgrade project.

Wellness Grant

An assistance to firefighters grant through FEMA was awarded to the Sheboygan Fire Department for the improvement and expansion of fitness and general wellness of the members of the fire department. This grant proposal is competitive and the department was fortunate to have their proposal funded. As a result of the grant, the department was able to contract with an outside fitness consultant, purchase a wide variety of exercise equipment for each station, train a core group of department members as fitness trainers, and also provide National Fire Protection Association compliant physicals for firefighters for the entire department. These physicals were designed specifically for the issues that are of concern for firefighters and the hazards they face on the job.

Response Statistics

Total Number of Responses

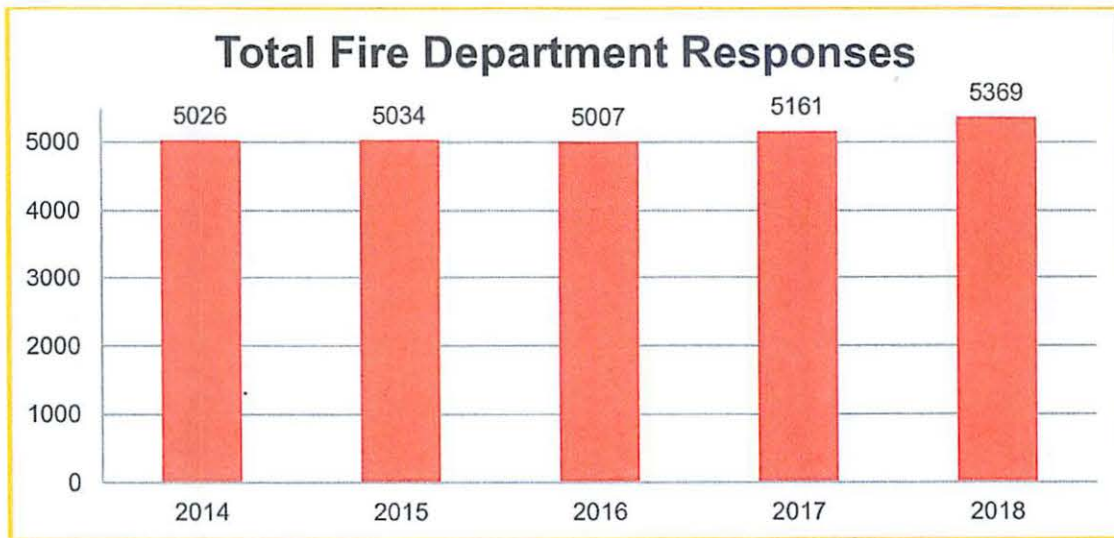

Types of Non EMS/Rescue Incidents

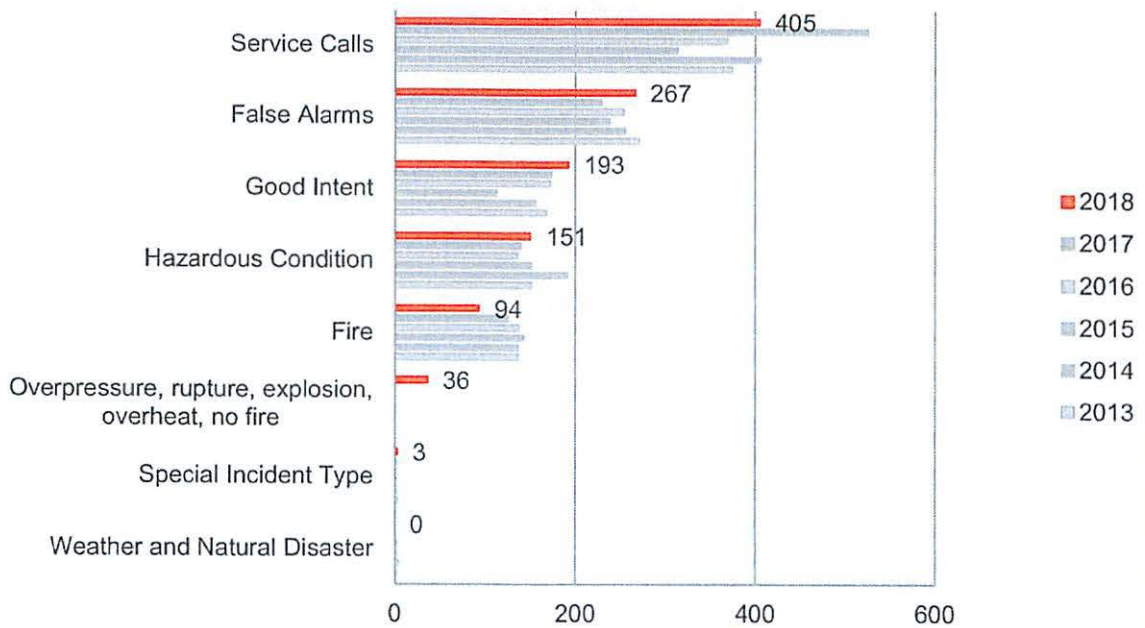

2018 Calls by Day of Week

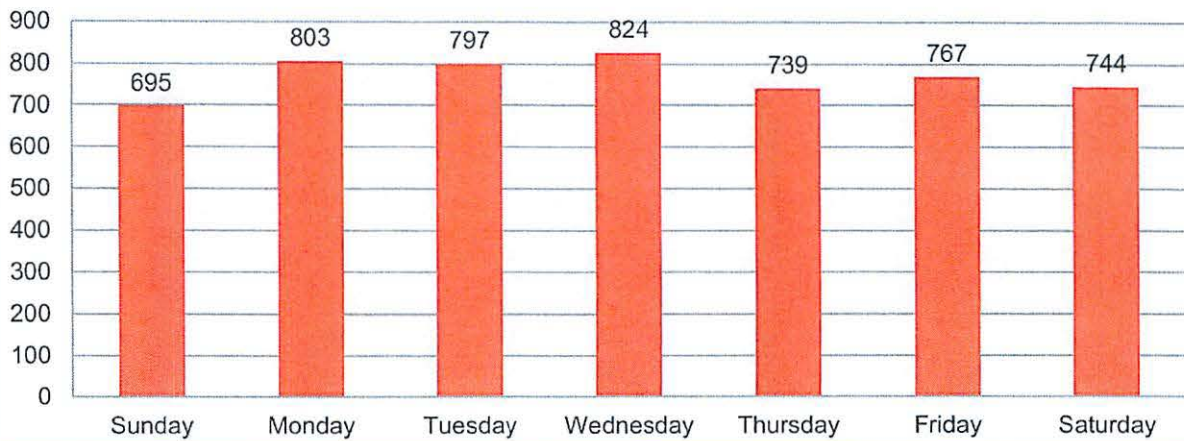

Sheboygan Fire Department Annual Report | 2018

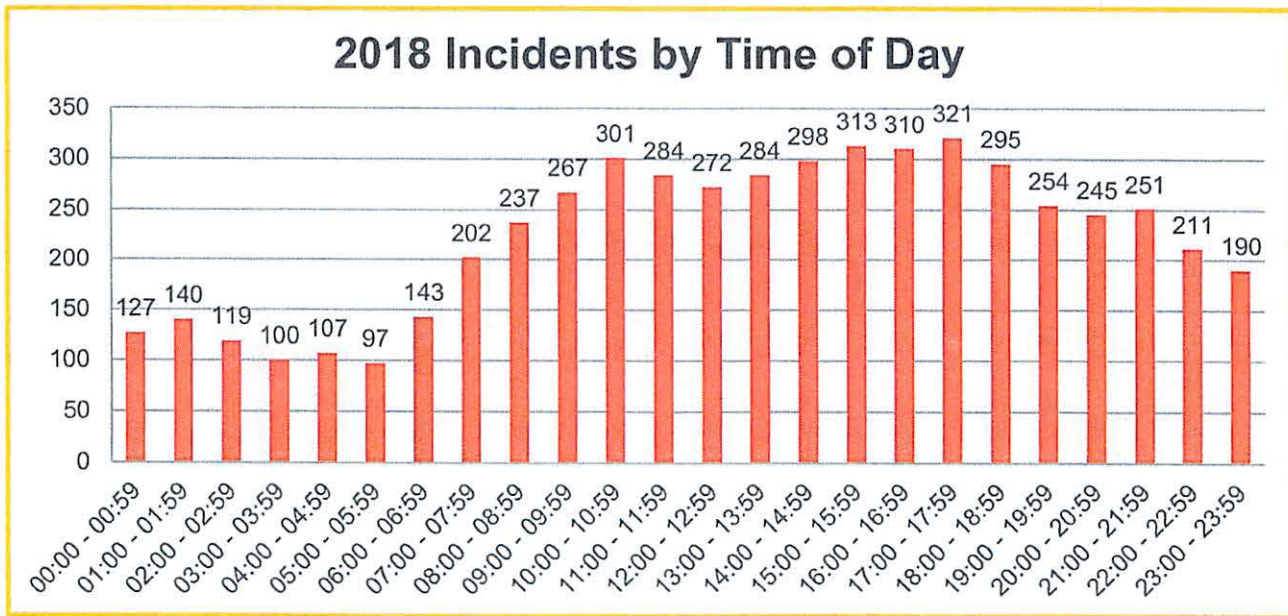

The *Calls by Day of Week* and *Calls by Time of Day* graphs are indicators of when requests for the Fire Department occur in Sheboygan. While there are some patterns that are seen, these graphs match trends nationally overall and also indicate that requests happen at all times.

Mutual Aid Given/Received

| | 2014 | 2015 | 2016 | 2017 | 2018 |
|------------------------------------|------|------|------|------|------|
| Total Responses Out of City | 26 | 19 | 21 | 45 | 42 |
| Incidents with Mutual Aid Provided | 8 | 8 | 8 | 6 | 8 |
| EMS and Other | 18 | 11 | 13 | 39 | 34 |
| Incidents with Mutual Aid Received | 5 | 5 | 4 | 1 | 5 |

Fire Related Deaths

| | 2014 | 2015 | 2016 | 2017 | 2018 |
|-------------|------|------|------|------|------|
| Fire Deaths | 1 | 0 | 1 | 0 | 0 |

Concurrent Calls

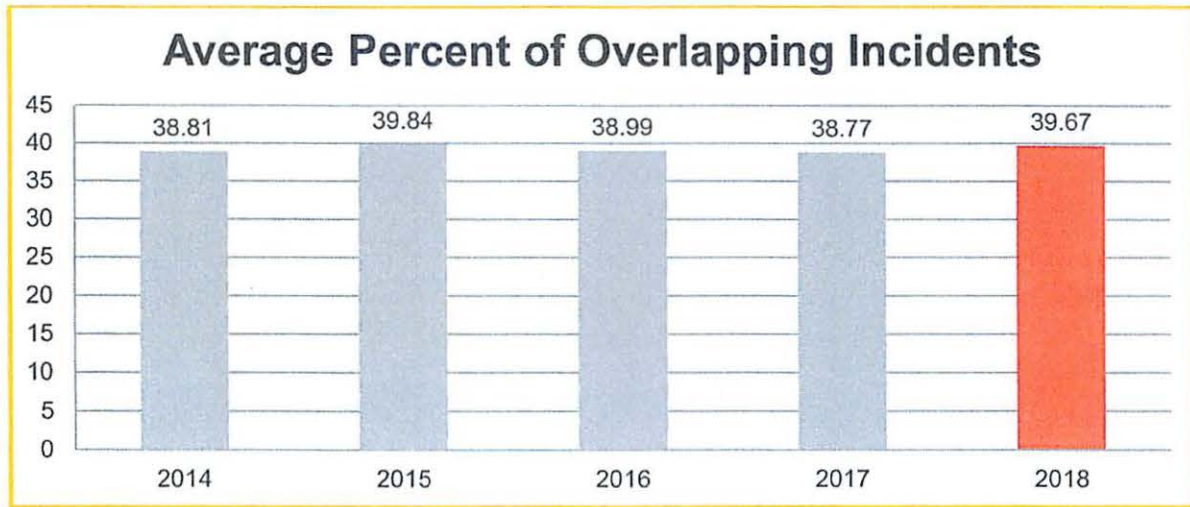

The measure of simultaneous calls represents the percentage of total call requests for the fire department while another call or multiple calls are already in progress. Generally speaking the call requests are random and in 2018 there was a slight increase in concurrent calls from the previous year, but that increase was insignificant and represented a relatively flat trend, which would suggest a relatively stable call volume overall with a consistent ability to handle the present call volume.

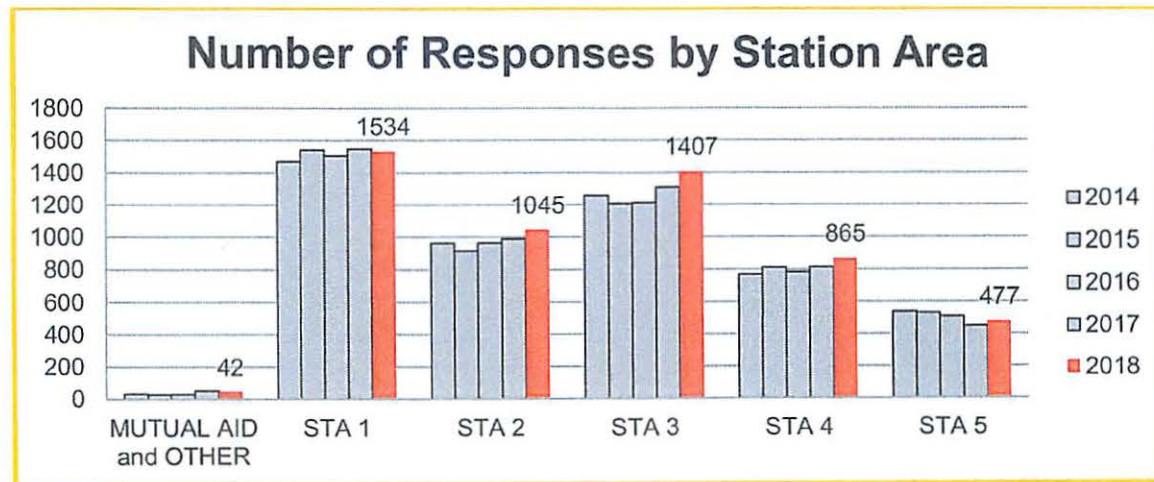

The *Response Requests by Station Area* graph is the total number of incidents as distributed by Fire Station Single Alarm response area as designated by the fire department. These response areas are established to maintain appropriate response times as set forth by the National Fire Protection Association (NFPA).



Emergency Medical Services

The Sheboygan Fire Department maintains a fleet of four ambulances for providing care and transport to the sick and injured. The department has continued to provide a quality, consistent, and compassionate service to the community.

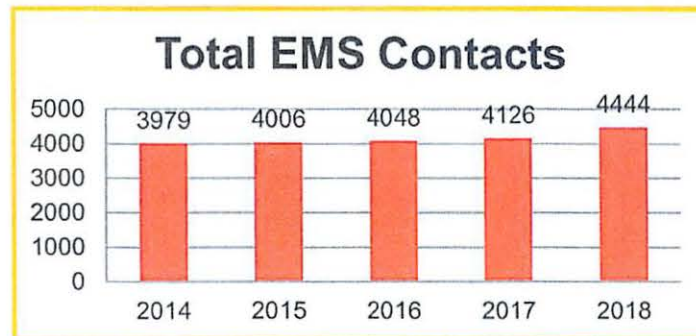

As a value-added service of the Fire Department, the revenues generated through the provision of the ambulance service aid in offsetting the cost of a effective and efficient fire department. This is done through the use of cross-trained personnel with a great deal of education and training and who are prepared to meet the emergency and non emergency needs of those it serves, whether it be a medical emergency, a fire, or another service need. Each ambulance vehicle also carries firefighting equipment for the firefighter/paramedics who staff those vehicles. This allows those personnel to also be able to respond to fires should they occur.

The Sheboygan Fire Department is interested in preventing injury that might cause need for someone to use an ambulance. As part of our injury prevention efforts, we have partnered with the Aging and Disability Resource Center (ADRC) in assisting with a referral program that provides for education and support from the ADRC for those who may need assistance or education about preventing falls in the home. When it is recognized through our contact, that a person might be in need of assistance or support, our crews will offer the referral and we will make contact with the ADRC to have them make contact with the individual and offer assistance. Our goal is to encourage every ambulance service in the county to provide this service and connection to the resources they need.

The Sheboygan Fire Department also is a key member of the recently created Dementia Crisis Care Task Force of Sheboygan County. It is the goal of this task force to improve all aspects of care to persons with dementia and in particular those who are suffering a crisis. The task force has focused on evaluating the current system in place for managing crisis situations, formulating improved, collaborative approaches to better manage those situations, and is providing county-wide education and changes to how these types of calls are being handled.

Fire Prevention and Public Education



In an effort to reduce the loss of life, injury, and property loss in the City of Sheboygan, the Sheboygan Fire Department is dedicated to providing education to the public as part of its mission.

While it is a core mission of the Sheboygan Fire Department to respond to and mitigate incidents in the City of Sheboygan, it is also the department's mission to reduce the number and severity of those incidents by proper code development and enforcement, effective and efficient response, and ongoing public education. It is through this continuous and comprehensive program of education that the

department maintains a culture of safety in the community.

As fire hazards presented to the public change, so will the program offerings to the public. It is the department's intent to keep educating the public to specific life hazards such as discarding (tossing) cigarettes in or outside of an occupancy and or removing fire safety equipment in an apartment space such as smoke detectors.

This general program area of public education is vital to the success of the fire department mission. The funding for the materials used for the school programs are largely generated through a program developed and operated by the National Fire Safety Council (NFSC). Each year, local businesses are solicited for donations toward the program by NFSC on the department's behalf and those funds are used by the department to purchase all of the fire prevention materials used in the public education programs delivered in the schools. We sincerely thank those who contribute to these funds and to this mission.

Using NFPA 1, the use operation and maintenance of all commercial buildings where employees work, and or the public has access and all common areas of 3 family or larger apartment complexes are inspected at least once in a calendar year. The Sheboygan Fire Department uses occupancy records software that tracks annual fire inspections and sends by email any code deficiencies to the owner or occupant. The software also keeps track of building preplan information such as type of occupancy, number of apartment units, chemical storage onsite and types of fire suppression equipment in a building.

Working with the Building and Planning Departments all new construction has a pre occupancy inspection while construction occurs and as fire systems come online in a building. After occupancy, a preplan of the building takes place noting all fire service equipment, utility shutoffs and chemical locations and type of construction are noted and added to our occupancy software. This information is held for the life of the building and is available for pre-incident planning as well as onsite mitigation during an incident.



FAMILIES PARTICIPATE IN ACTIVITY GAME
DESIGNED AND BUILT BY DEPARTMENT MEMBER

Training and Resource Development

The nature of the responsibilities of a fire department requires continuous training of its personnel to assure the best possible chance of a positive outcome when critical incidents occur. This is especially important when those events do not happen very often and you get one chance to get it right. Training and preparation is tailored to create effectiveness, efficiency, and safety when the fire department responds to incidents. The Sheboygan Fire Department provides for training of its employees through many different programs using a variety of methodologies that are designed to best meet the needs of the department both fiscally and operationally. Because of the inherent dangers present in the job, many of the training areas are statutorily mandated for the protection of both the employee and the citizens they serve.

In 2018, a focused effort was made on increasing training and education for Company Officers. This training covered items such as general leadership training, human resource and personnel skills, general supervisory skills, crew readiness, incident management, and many other topics designed to improve relationships and response and to decrease risk to personnel, the public, and to the City. That emphasis is reflected in the large administrative training category.

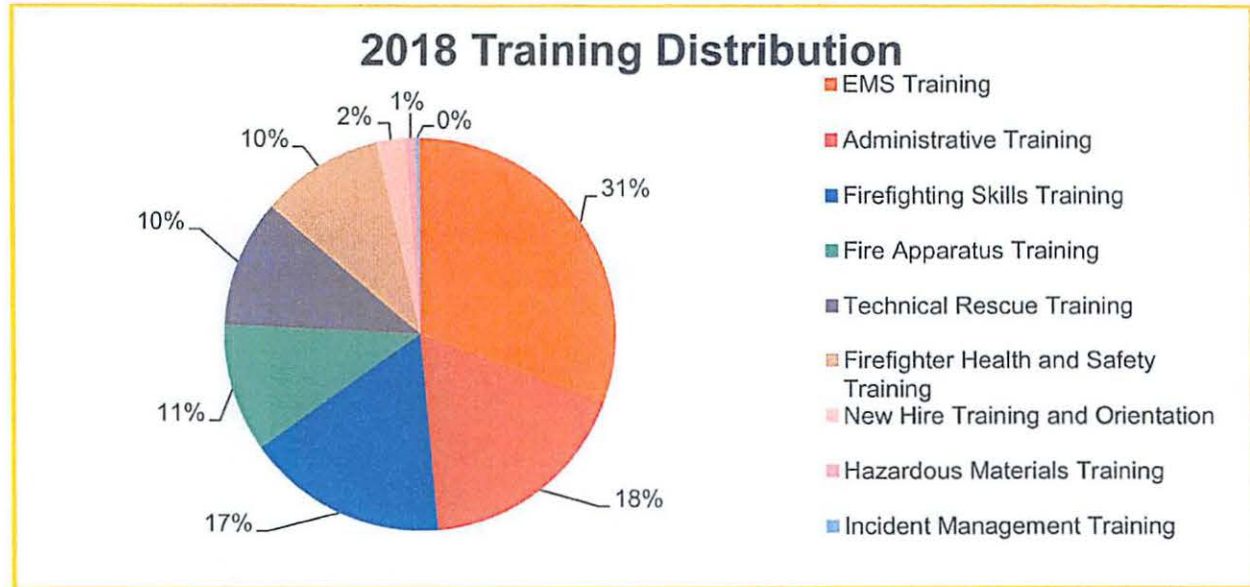

| CATEGORY | TOTAL HOURS |
|--|--------------|
| Emergency Medical Services Training | 3166 |
| Administrative Training | 1849 |
| Firefighting Skills Training | 1714 |
| Fire Apparatus Training | 1090 |
| Technical Rescue Training | 1089 |
| Firefighter Health and Safety Training | 1051 |
| New Hire Training and Orientation | 246 |
| Hazardous Materials Training | 86 |
| Incident Management Training | 34 |
| TOTAL TRAINING HOURS | 10325 |

Retirements in 2018



ASSISTANT CHIEF
VERNON KOCH



LIEUTENANT
BLAINE WERNER



FEO
KURT SPATT



FEO
MICHAEL TOTH



FEO
TODD McLAUGHLIN



FEO
JOSEPH RAML



FEO
MARK ZEMKE

Promotions in 2018



CAPTAIN
JEFFERY SALZMAN



LIEUTENANT
KURT MILLER

New Employees



FIREFIGHTER/PARAMEDIC
STEVEN BOYLE



FIREFIGHTER/PARAMEDIC
ANTHONY WENZEL



FIREFIGHTER/PARAMEDIC
KYLE WAM

New Hire Training

When newly hired personnel enter the Sheboygan Fire Department, it is important for the department to get them up to speed and into their day-to-day positions as soon as possible. It is also critical to their performance and safety that they are properly familiarized with their assignments and how to perform them according to the standards and expectations of the department.

The training division of the fire department works diligently to assure that these new firefighters have all of the tools necessary to perform their jobs. New firefighters are given intensive department familiarization through a year-long probationary period that begins with 3 weeks of direct instruction on 8 hour days prior to moving on to the 24 hour duty rotation. They are issued gear, brought up to speed on pertinent policies and procedures, tested on their driving performance for ambulance vehicles, their medical care and their firefighting skills, and even tested on historical facts and background on the fire department. All of this helps to build a sense of team and family as a member of the Sheboygan Fire Department.

Everyone coming into the department has education, certifications, and licenses as a condition of hire, but it is up to the department to verify that information and skill set and to expand that knowledge with department-specific information related to their new employment prior to placing them in the field providing medical care and entering hazardous situations.



In Memoriam



Vilas Vreeke

Born:
Appointed: 1964
Retired: 1991
Retired as a Fire Equipment Operator
Returned to Quarters: 2018



Thomas Murray

Born:
Appointed: 1961
Retired: 1990
Retired as a Lieutenant
Returned to Quarters: 2018

**“What we do for ourselves dies with us. What we do for others and
the world remains and is immortal.”**

Albert Pine

CITY OF SHEBOYGAN

REQUEST FOR LICENSES, HEARINGS AND PUBLIC SAFETY

ITEM DESCRIPTION: Resolution by Alderpersons Donohue & Sorenson to authorize the appropriate City Officials to enter into contract for the purchase and installation of (41) replacement window units at Fire Station # 1.

REPORT PREPARED BY: Bernard R. Rammer Purchasing Agent

REPORT DATE: March 18, 2019

MEETING DATE: April 10, 2019

FISCAL SUMMARY:

Budget Line Item: 47822100-621200
Budget Summary: 2019 Capital
Improvements
Budgeted Expenditure: \$ 124,900.00
Budgeted Revenue: N/A

STATUTORY REFERENCE:

Wisconsin Statutes: N/A
Municipal Code: N/A

BACKGROUND / ANALYSIS:

As part of the Fire Station # 1 improvements, The Sheboygan Fire Dept. will be replacing a total of (41) window units which were installed in the early/mid 1980's with new, energy efficient units. In addition to increased efficiency, the windows will also be aesthetically pleasing and will replace the painted upper energy panels with insulated glass.



STAFF COMMENTS:

The windows to be installed are Energy Star rated and feature a limited lifetime warranty. In addition, the windows will filter out nearly all of the ultraviolet rays which can be detrimental to turnout gear utilized by firefighters. A Request for bids was issued and the City received three competitive bids.

- Jos. Schmitt & Sons, Sheboygan....\$126,233.00
- Mike Koenig Construction, Sheboygan.....\$124,900.00
- A. Chappa Construction, Sheboygan Falls, WI\$ 126,800.00

Following a review of the bids, the low bid received from Mike Koenig Construction of Sheboygan meets all of the requirements and staff recommends award.

In addition, due to the energy efficiency of these proposed windows, the city will receive a Focus on Energy grant in the amount of \$ 1,543.56 following completion of the project.

ACTION REQUESTED:

A Motion to recommend that the Council approve Resolution # 188-18/19 to authorize the appropriate City Officials to enter into contract for purchase and installation of (41) replacement window units for Fire Station # 1 including removal and disposal of the old units with Mike Koenig Construction of Sheboygan in the amount of \$ 124,900.00

ATTACHMENTS:

- I. Res # 188- 18/19

Res. No. 188 - 18 - 19. By Alderpersons Donohue and Sorenson.
March 18, 2019.

A RESOLUTION authorizing the appropriate City Officials to enter into a contract with Mike Koenig Construction Co., Inc. for the installation of replacement windows at Sheboygan Fire Department Station #1.

WHEREAS, the 2019 Capital Improvements Budget contemplates the replacement of forty-one (41) windows in Sheboygan Fire Department Station #1 with energy efficient, historically correct windows (the "Window Replacement"); and

WHEREAS, City Staff has obtained and reviewed competitive bids for the Window Replacement, and has determined that the low bid, submitted by Mike Koenig Construction Co., Inc. of Sheboygan, Wisconsin, meets all the requirements from the bid documents; and

WHEREAS, the Common Council of the City of Sheboygan believes that it is in the best interest of the City to award a contract to Mike Koenig Construction Co., Inc. for the Window Replacement.

NOW, THEREFORE, BE IT RESOLVED: That the Mayor and City Clerk are hereby authorized and directed to enter into a contract with Mike Koenig Construction Co., Inc., a copy of which is attached hereto and incorporated herein, for the installation of replacement windows at Sheboygan Fire Department Station #1.

BE IT FURTHER RESOLVED: That the appropriate City Officials are hereby authorized to draw funds in the amount of \$124,900.00 from 2019 Capital Improvements Fund - Fire - Building Improvement Account No. 47822100-621200 for the purchase and installation of windows, including disposal of the old units.

LHPS

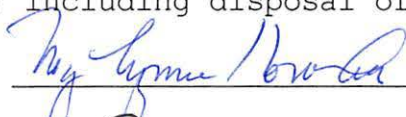

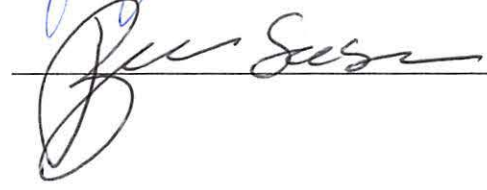

I HEREBY CERTIFY that the foregoing Resolution was duly passed by the Common Council of the City of Sheboygan, Wisconsin, on the _____ day of _____, 20____.

Dated _____ 20____. _____, City Clerk
Approved _____ 20____. _____, Mayor

**AGREEMENT
BETWEEN THE CITY OF SHEBOYGAN, WISCONSIN AND
MIKE KOENIG CONSTRUCTION CO., INC.**

**REGARDING THE INSTALLATION OF REPLACEMENT WINDOWS
AT
SHEBOYGAN FIRE STATION NUMBER 1**

This Agreement (“Agreement”) is made and entered into effective this ____ day of _____, 2019 (the “Effective Date”), by and between the City of Sheboygan (the “City”), a municipal corporation, and Mike Koenig Construction Co., Inc. (“Mike Koenig Construction”).

WITNESSETH:

WHEREAS, the City is the owner of Fire Station Number 1, located at 833 New York Ave. in Sheboygan, Wisconsin (“Fire Station #1”); and

WHEREAS, in 2018 the City began a two year project to rehabilitate Fire Station #1; and

WHEREAS, as part of that rehabilitation, at this time the City wishes to replace the existing windows at Fire Station #1 with historically appropriate commercial grade fiberglass composite windows having high efficiency and operable internal blinds (“Window Replacement”); and

WHEREAS, the City issued Request for Bids # 1953-19 to obtain bids from qualified providers of the materials and services needed to complete the Window Replacement (“Services”); and

WHEREAS, the City has opened the bids, and determined that the bid from Mike Koenig Construction (“Bid”) is the lowest responsive and responsible bid for the Services; and

WHEREAS, a copy of the Bid is attached to this Agreement and incorporated herein by reference; and

WHEREAS, Mike Koenig Construction desires to provide the City with the necessary Services under the terms set forth in this Agreement.

NOW, THEREFORE, in consideration of the mutual covenants herein contained, the parties hereto agree as follows:

Article 1. Scope of Services

Mike Koenig Construction shall provide everything necessary—including, but not limited to, materials, labor, equipment, licenses, permits¹, bonds, and travel expenses—to fully and properly complete installation of forty-one (41) commercial grade replacement window units at Fire Station #1 pursuant to the manufacturers' specifications. Such information as is necessary to give a comprehensive idea of the construction contemplated are shown on the attached documents from Pella Window and Door Showroom of Green Bay, which are incorporated herein by reference.

1. Materials

All materials provided in order to complete the Services pursuant to this Agreement shall be new, newest model year, and free from defects.² Windows shall have a pre-finished interior, a maintenance free exterior and be "Dark Bronze" in color so as to match the door frames of the recently installed doors. Additionally, as provided in the Request for Bids, the windows shall meet the following criteria:

- Commercial grade and constructed of fiberglass composite
- Fixed casement with vented awning units
- Have the appearance of being "double-hung" to mimic the original look of the structure.
- All of the windows shall have the upper pane in insulated spandrel glass.
- The transom window shall be insulated spandrel glass.
- All windows shall be double or triple glazed and have an aggressive "Low E" Argon glazing
- The center of glass performance values shall be:
 - U Value = .19
 - SHGC = .25
 - UV Transmission = 4%
- Extruded aluminum historic brick-mold shall be installed around the exterior perimeter
- All first floor windows shall have fixed glass casements.
- All second floor units shall have fixed transoms with insulated spandrel glass over venting awning units.
- Second floor awning units shall be custom sized to match existing interior cased openings.
- The new windows shall be designed in such a way as to conceal the second floor's suspended ceiling grid system from visibility on the exterior.

¹ Mike Koenig Construction shall be responsible for obtaining any and all applicable City permits and paying any and all applicable permit fees prior to beginning work.

² The City reserves the right to employ an independent testing laboratory to conduct tests of materials as the City may deem necessary to assure complete compliance with the requirements of the specifications. Mike Koenig Construction shall offer full cooperation with respect to such testing.

2. Installation

Complete installation of the windows shall include any new trim and moldings necessary as a result of the installation of the replacement window units. All installation work shall be done by personnel trained and certified by the window manufacturer to install windows. It shall also include removal and disposal of all old windows at Fire Station #1, and complete restoration of any surfaces disturbed, including—but not limited to—drywall, wood trim, painted or stained surfaces, ceiling grid work, ceiling tiles, insulation, and exterior sealants. Additionally, as provided in the Request for Bids, the installation shall include the following:

- If required for removal of the existing windows and/or the installation of the new windows, existing finished oak trim on the second floor is to be removed and replaced.
- If required for removal of the existing windows and/or the installation of the new windows, existing drywall at window openings is to be removed and replaced.
- If wood trim or drywall requires removal and replacement, Mike Koenig Construction shall be responsible for all painting, staining, and finishing.
- One of the windows is a “transom” over an exterior door. The door manufacturer has provided the frame. Mike Koenig Construction shall provide and install an appropriate glass pane into the frame and install the frame into the opening.

3. Other Responsibilities

As it conducts the Services provided by this Agreement, Mike Koenig Construction shall also do the following:

- Conduct a Pre-Construction Conference, and any other conference or meeting that either Party believes is necessary or useful in ensuring the orderly administration of the work under this Agreement.
- Provide a competent supervisor and supporting technical personnel that are acceptable to the City throughout the entire installation. Change of the supervisor during the installation shall not be acceptable without prior written approval from the City.
- Report, in writing, any discrepancies found between the Contract (as defined in Article 29) and site conditions or any inconsistencies or ambiguities in the Contract. The City shall promptly correct such inconsistencies or ambiguities in writing. The City’s designated project manager is authorized to make such corrections. Work done by Mike Koenig Construction after his discovery of such discrepancy, inconsistency, or ambiguity shall be done at the risk of Mike Koenig Construction.
- Shall not deviate from the Contract (as defined in Article 29) without the written consent of the City. An unauthorized deviation shall be corrected at the expense of Mike Koenig Construction in a manner satisfactory to the City.
- At all times, keep the premises free from accumulation of waste materials or rubbish.
- At the completion of the Services, remove all waste materials, rubbish, tools, construction equipment, machinery, and surplus materials, leaving the work site in a condition comparable or better to that at the beginning of the Services.

- During Final Inspection, Mike Koenig Construction shall provide a knowledgeable representative to assist in the inspection of the completed Services for conformance with the Contract. The City shall prepare a Punch List that provides all items Mike Koenig Construction must complete prior to Final Acceptance. Any deficiencies shall be promptly and permanently corrected prior to Final Acceptance, and shall be the full responsibility of Mike Koenig Construction.

Article 2. Standard of Care

Mike Koenig Construction shall be responsible for completion of the Services in a manner consistent with that degree of care and skill ordinarily exercised by members of the same profession currently practicing under similar circumstances (“Standard of Care”). The City shall be the sole judge of the adequacy of Mike Koenig Construction’s work in meeting the Standard of Care; however, the City shall not unreasonably withhold its approval as to the adequacy of Mike Koenig Construction’s performance. Upon notice to Mike Koenig Construction and by mutual agreement between the parties, Mike Koenig Construction will, without additional compensation, correct or replace any and all Services not meeting the Standard of Care.

Mike Koenig Construction shall be solely responsible for all construction means, methods, techniques, sequences, and procedures, and for coordinating all portions of the Work under this Agreement, including materials used.

Article 3. Responsibilities of the City

The City designates Bernie Ramer as its designated project manager for purposes of this Agreement. If the City’s designated project manager deems it appropriate, the City’s designated project manager may consult with other employees of the City, or may retain an appropriate outside expert to assist with the management of this Project.

Article 4. Compensation

The City shall pay Mike Koenig Construction for all fees and expenses in an amount not to exceed One Hundred Twenty Four Thousand Nine Hundred and 00/100 Dollars (\$124,900.00). Invoices shall be sent via first class mail postage prepaid. Payment will be remitted to Mike Koenig Construction within forty-five (45) days of receipt of invoice. Mike Koenig Construction shall submit an invoice to the City on a monthly basis and shall be based on the percentage complete of the Services described in Article 1. The invoice shall be sent to:

Bernie Rammer
City of Sheboygan
828 Center Ave.
Sheboygan, Wisconsin 53081

Additional services not set forth in Article 1, or changes in the Services must be authorized in writing by the City or its designated project manager prior to such work being performed, or expenses incurred. The City shall not make payment for any unauthorized work or expenses.

The City may withhold payment, in whole or in part, to the extent necessary to protect itself from a loss on account of any of the following:

- Defective work.
- Evidence indicating the probable filing of claims by other parties against Mike Koenig Construction which may adversely affect the City.
- Failure of Mike Koenig Construction to make payments due to subcontractors, material suppliers, or employees.
- Damage to the City or a third party.

The submission of any request for payment shall be deemed a waiver and release by Mike Koenig Construction of all liens and claims with respect to the work and period to which such payment request pertains except as specifically reserved and noted on such request.

Partial payment made under this Agreement is not evidence of the proper performance by Mike Koenig Construction either in whole or in part, and no payment made by the City shall be construed to be an acceptance of defective or improper work. Acceptance of the work by the City shall occur only upon Final Payment by the City which will occur after Final Acceptance. The Parties recognize that more than 45 days may elapse between the submission of the last invoice and Final Acceptance or Final Payment. The City agrees to make reasonable efforts to schedule its Final Inspection in a timely manner and to process the Final Payment in a timely manner upon Final Acceptance. (For the avoidance of doubt, the warranties and guarantees in this Agreement shall continue to apply even after Final Payment by the City.)

Article 5. Appropriation of Funds

Notwithstanding any other provision of this Agreement, if funds for the continued fulfillment of this Agreement by the City are at any time not forthcoming or are insufficient, through failure of any entity, including the City itself, to appropriate funds or otherwise, then the City shall have the right to terminate this Agreement without penalty. The City agrees that it will make its best effort to obtain sufficient funds for the Agreement to meet its obligations hereunder in full.

Article 6. Performance and Payment Bond

Mike Koenig Construction shall, within fifteen (15) days of the approval of this Agreement by the Common Council of the City of Sheboygan, provide the City with a Performance Bond and a Payment Bond in the amount of one hundred percent (100%) of the contract amount.

Failure by Mike Koenig Construction to perform the work in a timely or satisfactory fashion may result in forfeiture of Mike Koenig Construction's Performance Bond.

If the Surety on any bond furnished by Mike Koenig Construction becomes a party to supervision or liquidation, or its right to do business in the State of Wisconsin is terminated, Mike Koenig Construction shall, within thirty (30) calendar days thereafter, substitute another bond or surety, both of which must be acceptable to the City.

Article 7. Schedule

Mike Koenig Construction shall order the windows promptly upon execution of this Agreement. It is estimated that it will take approximately forty-five (45) days from when the windows are ordered to when they will be available. It is estimated that it will take an additional one hundred twenty (120) days from the receipt of the windows to install the windows. Absent force majeure, Final Acceptance shall occur by September 30, 2019, or within such extra time as may have been allowed by a mutually agreed extension.

Mike Koenig Construction shall provide the City with a projected schedule of activities, so that the City and its representatives may plan site visits. The schedule shall include, at a minimum, the date upon which work is expected to commence, the date upon which work is expected to be completed, and the date of expected Final Installation. Mike Koenig Construction is responsible to notify the City of any changes in their activity schedule due to change in the overall construction schedule or Mike Koenig Construction's schedule.

The Parties agree that no charges or claims for damages shall be made by Mike Koenig Construction for any delays or hindrances, from any cause whatsoever, during the progress of any portion of the services specified in the Agreement. Such delays or hindrances, if any, may be compensated for by an extension of time for a reasonable period as may be mutually agreed upon between the Parties, it being understood however, that permitting Mike Koenig Construction to proceed to complete any service, or any part of the services / project, after the date to which the time of completion may have been extended shall, in no way operate as a waiver on the part of the City of any of its rights herein.

Article 8. Liquidated Damages

In the event that Mike Koenig Construction does not complete the Services by the date set forth in Article 7 (as potentially amended), there shall be deducted from any monies due or that may become due to Mike Koenig Construction, for each and every calendar day that the work remains uncompleted, a sum of One Hundred and 00/100 Dollars (\$100.00) per calendar day.

This sum shall be considered and treated not as a penalty but as fixed, agreed, and liquidated damages due the City from Mike Koenig Construction by reason of inconvenience to the public, added cost of supervision, and other items which have caused an expenditure of public funds resulting from his failure to complete the work.

Permitting Mike Koenig Construction to continue and finish the work or any part of same after the time fixed for its completion, or after the date to which the time for completion may have been extended, shall in no way be construed as a waiver on the part of the City of any of its rights under this Agreement.

Article 9. Workmanship and Quality of Materials

Mike Koenig Construction guarantees that the workmanship to complete the Services provided under this Agreement for a period of not less than three (3) years after final acceptance by the City. This guarantee shall cover the replacement of any and all parts and labor to replace any and all parts made necessary by normal usage and wear.

Mike Koenig Construction shall ensure that the windows qualify for a manufacturer's warranty of at least ten (10) years against defects when said defects are the result of normal daily usage. This warranty shall cover the replacement of any and all parts and labor to replace any and all parts made necessary by normal usage and wear.

Whenever, in any document, an article, material, or equipment is defined by describing a proprietary product, or by using the name of a manufacturer or vendor, the term "or equal" or the term "the equivalent" if not inserted, shall be implied, and it is done for the express purpose of establishing a basis of durability and efficiency and not for the purpose of limiting competition. Whenever material or equipment is submitted for approval as being equal to that specified, the submittal shall include sufficient information and data to demonstrate that the material or equipment conforms to all contractual requirements. The decision as to whether or not such material or equipment is equal to that specified shall be made by the City. The approval by the City of alternate material or equipment as being equivalent to that specified shall not in any way relieve Mike Koenig Construction of responsibility for failure of the material or equipment due to faulty design, material, or workmanship, to perform the function required by the contract documents. The City shall be the sole and final judge of equivalency.

Article 10. Safety Requirements

All materials, equipment, and supplies provided to the City must comply fully with all safety requirements set forth under state and federal law.

Mike Koenig Construction shall be responsible for the safety of employees at all times and shall provide all equipment necessary to insure their safety. Mike Koenig Construction shall ensure the enforcement of all applicable safety rules, regulations, ordinances and laws, whether federal, state, or local. Mike Koenig Construction's Superintendent of Safety shall make daily inspections upon the arrival and leaving of the site at the close of each workday.

Article 11. Open Records

Both parties understand that the City is bound by the Wisconsin Public Records Law and, as such, this contract is subject to that law. Mike Koenig Construction acknowledges that it is obligated to assist the City in retaining and producing records that are subject to Wisconsin Public Records Law, and that the failure to do so shall constitute a material breach of the contract, and that Mike Koenig Construction must defend and hold the City harmless from liability under that law. Except as otherwise authorized, those records shall be maintained for a period of seven (7) years after receipt of Final Payment under the Agreement.

Article 12. Termination

The City may terminate or suspend performance of this Agreement at the City's prerogative at any time upon written notice to Mike Koenig Construction. Mike Koenig Construction shall terminate or suspend performance of the Services on a schedule acceptable to the City and the City shall pay Mike Koenig Construction for all the Services performed up to the date that written notice is received, plus reasonable termination or suspension expenses. Upon restart, an equitable adjustment shall be made to Mike Koenig Construction's compensation and the schedule of services.

If Mike Koenig Construction defaults or fails to fulfill in a timely and proper manner its obligations pursuant to this Agreement, the City may, fifteen (15) days after written notice has been delivered to Mike Koenig Construction, and without prejudice to any other remedy it may have, make good such deficiencies and may deduct the cost thereof from the payment then or thereafter due to Mike Koenig Construction. In the alternative the City may, at its option, terminate this Agreement and take possession of the site and of all materials, equipment, tools, and construction equipment and machinery thereon owned by Mike Koenig Construction, and may finish the project by whatever method it may deem expedient. In case the expenses incurred by the City (including payments previously made to Mike Koenig Construction) shall be less than the sum which would have been payable under the Agreement if it had been completed by Mike Koenig Construction, Mike Koenig Construction shall be entitled to receive the difference. However, in case such expense shall exceed the sum which would have been payable under the Agreement, Mike Koenig Construction will be liable and shall pay to the City the amount of said excess. By taking over prosecution of the work, the City does not forfeit the right to recover damages from Mike Koenig Construction or its surety for failure to complete the work in the time specified.

Article 13. Default

If Mike Koenig Construction breaches this Agreement or fails to perform the work in an acceptable manner, it shall be considered in default. Any one or more of the following will be considered a default:

- Failure to begin the work under this Agreement within the time specified.
- Failure to perform the work with sufficient supervision, workers, equipment and materials to insure prompt completion of said work within the time limits allowed.
- Unsuitable performance of the work as determined by City.
- Neglecting or refusing to remove defective materials or failure to perform anew such work as shall have been rejected.
- Discontinuing the prosecution of the work or any part of it.
- Inability to finance the work adequately.
- If, for any other reason, Mike Koenig Construction breaches this Agreement or fails to carry on the work in an acceptable manner.

The City shall send Mike Koenig Construction a written notice of default. If Mike Koenig Construction, within a period of seven (7) days after such notice, fails to remedy the default, then the City shall have full power and authority, without violation of the Agreement, to take the

prosecution of the work out of the hands of Mike Koenig Construction, as set forth in this Agreement.

Article 14. Identity of Mike Koenig Construction

Mike Koenig Construction acknowledges that one of the primary reasons for its selection by the City to perform the Services is the qualifications and experience of Mike Koenig Construction. Mike Koenig Construction thus agrees that the Services to be performed pursuant to this Agreement shall be performed by Mike Koenig Construction. Mike Koenig Construction shall not subcontract any part of the Services without the prior written permission of the City. The City's project manager shall have the ability to provide this written permission. The City reserves the right to reject any of the Mike Koenig Construction's personnel or proposed outside professional sub-consultants, and the City reserves the right to request that acceptable replacement personnel be assigned to the project.

Article 15. Independent Contractor Status

During the entire term of this Agreement, Mike Koenig Construction shall be an independent contractor, and in no event shall any of its personnel, agents or sub-contractors be construed to be, or represent themselves to be, employees of the City. Mike Koenig Construction shall be solely responsible for the payment and reporting of all employee and employer taxes, including social security, unemployment, and any other federal, state, or local taxes required to be withheld from employees or payable on behalf of its employees.

Article 16. Indemnification

Mike Koenig Construction is responsible to the City for the acts and omissions of its employees, subcontractors, and any other persons performing any of the work under a contract with Mike Koenig Construction.

As such, Mike Koenig Construction shall indemnify, defend, and hold the City—including its Officials, Agents, and Employees—free and harmless from all liability, including, but not limited to, losses, damages, costs, attorney's fees, expenses, causes of action, claims, or judgments resulting from claimed injury, death, damage to property, or loss of use of property or any person or legal entity arising out of or in any way connected with the performance of work or work to be performed under this Agreement.

Mike Koenig Construction shall reimburse the City for any costs, expenses, judgments, and attorney's fees paid or incurred, by or on behalf of the City, its Officials, Agents, or Employees, or paid for on behalf of the City, its Officials, Agents, or Employees by insurance purchased or self-insurance provided by the City.

For the avoidance of doubt, Mike Koenig Construction shall further hold harmless the City, its Officials, Agents, and Employees from liability or claims for any injuries to or death of Mike Koenig Construction's employees (or the employees of any authorized subcontractor) arising out of or in any way connected with the work or work to be performed under this Agreement, including protection against any claim of the contractor or subcontractor for any payments under any worker's compensation law or any expenses of or any payments made by any worker's compensation

insurance carrier on behalf of said contractor or sub-contractor and the contractor shall indemnify the City for any costs, expenses, judgments, and attorney's fees with respect to any above referenced workers' compensation claims incurred or paid by the City or paid on its behalf or on behalf of its Officials, Agents, or Employees by insurance purchased or self-insurance provided by the City.

Article 17. Insurance

Mike Koenig Construction shall not commence work under this Agreement until it has obtained all insurance required under this Article. Additionally, Mike Koenig Construction shall not allow any approved subcontractor to commence work on its subcontract until the subcontractor has obtained all insurance required under this Article.

During the performance of any and all Services under this Agreement, Mike Koenig Construction shall maintain the following insurance in full force and effect, and shall provide proof of insurance to the Purchasing Agent listing the City of Sheboygan as an additional insured:

- a. Workers' Compensation Insurance – Mike Koenig Construction shall acquire and maintain, for the duration of the Agreement, Workers' Compensation Insurance that meets all statutory requirements. In the event this Agreement authorizes any work to be sublet, Mike Koenig Construction shall require any subcontractor to similarly provide Workers' Compensation Insurance in accordance with all statutory requirements.
- b. Commercial General Liability Insurance – Mike Koenig Construction shall acquire and maintain, for the duration of this Agreement, Commercial General Liability Insurance with a policy limit of at least \$1,000,000 per occurrence and \$2,000,000 in the aggregate. This Commercial General Liability Insurance policy shall include coverage for XCU hazards.
- c. Comprehensive Automobile Liability Insurance – Mike Koenig Construction shall acquire and maintain, for the duration of this Agreement, Comprehensive Automobile Liability Insurance with a policy limit of at least \$1,000,000 per occurrence.
- d. Umbrella Liability Insurance – Mike Koenig Construction shall acquire and maintain, for the duration of this Agreement, an Umbrella Liability Insurance policy with a policy limit of at least \$2,000,000 and a deductible of no more than \$10,000.

The proof of insurance referenced above shall require the insurance company to notify the City at least thirty (30) days prior to the expiration, cancellation, non-renewal, or material change in the coverage. The Certificate Holder on the proof of insurance should be listed as:

City of Sheboygan, Wisconsin
Bernard Rammer – Purchasing Agent
828 Center Ave., Suite 205
Sheboygan, Wisconsin 53081

The proof of insurance must contain an original signature.

The City is self-insured for Builder's Risk coverage on this Project. Mike Koenig Construction shall be responsible for the first \$10,000 of any claim related to Builder's Risk coverage.

Approval of the insurance by the City shall not relieve or decrease the extent to which Mike Koenig Construction may be held responsible for payment of damages resulting from Mike Koenig Construction's provision of the Services or its operations under this Agreement. If Mike Koenig Construction fails or refuses to procure or maintain the insurance required by these provisions, or fails or refuses to furnish the City the required proof that the insurance has been procured and is in force and paid for, the City shall have the right at its election to terminate the Agreement.

Article 18. Conflict of Interest

Mike Koenig Construction declares that it has no present interest, nor shall it acquire any interest, direct or indirect, which would conflict with the performance of Services under this Agreement. Mike Koenig Construction agrees that no person having any such interest shall be employed in the performance of this Agreement.

Article 19. Waiver

No failure of either party to enforce a term of this Agreement against the other shall be construed as a waiver of that term, nor shall it in any way affect the party's right to enforce that term. No waiver by any party of any term of this Agreement shall be considered to be a waiver of any other term or breach thereof.

Article 20. Severability

The invalidity, illegality or unenforceability of any provision of this Agreement or the occurrence of any event rendering any portion or provision of this Agreement void shall in no way affect the validity or enforceability of any other portion or provision of this Agreement. Any void provision shall be deemed severed from this Agreement, and the balance of the Agreement shall be construed and enforced as if it did not contain the particular provision held to be void. The parties further agree to amend this Agreement to replace any stricken provision with a valid provision that comes as close as possible to the intent of the stricken provision. The provisions of this Article shall not prevent this entire Agreement from being void should a provision which is of the essence of this Agreement be determined void.

Article 21. Assignment

Neither the City nor Mike Koenig Construction shall assign any rights or duties under this Agreement without the prior written consent of the other party.

Article 22. Third Party Rights

Nothing in this Agreement shall be construed to give any rights or benefits to anyone other than the City and Mike Koenig Construction.

Article 23. Governing Law and Venue

This Agreement shall be governed by the laws of the State of Wisconsin. Venue of any disputes arising under this Agreement shall be in the Sheboygan County Circuit Court, Wisconsin.

Article 24. Non-Discrimination

In connection with the performance of work under this Agreement, Mike Koenig Construction agrees not to discriminate against any employee or applicant for employment because of age, race, religion, color, handicap, sex, physical condition, developmental disability (as defined in Wis. Stat. 51.01(5)), sexual orientation (as defined in Wis. Stat. 111.32(13m)), or national origin. This provision shall include, but not be limited to, the following: employment, upgrading, demotion or transfer, recruitment or recruitment advertising, layoff or termination, rates of pay or other forms of compensation, and selection for training, including apprenticeship. Mike Koenig Construction further agrees to take affirmative action to ensure equal employment opportunities.

Article 25. Compliance with Laws

In performing the Services under this Agreement, Mike Koenig Construction shall comply with any and all applicable federal, state and local statutes, ordinances, plans, and regulations.

The City reserves the right to cancel this Agreement if Mike Koenig Construction fails to follow the requirements of Wis. Stat. 77.66 and related statutes regarding certification for collection of sales and use tax. The City also reserves the right to cancel this Agreement with any state or federally debarred contractor.

Mike Koenig Construction shall have any and all licenses and permits required to perform the work specified, and shall furnish proof of such licensing authorization and permits upon request.

Article 26. Notices

Any notice required by this Agreement shall be made in writing to the individuals/addresses specified below:

City:

Mike Koenig Construction:

| | |
|----------------------------|------------------------------------|
| City Clerk | Michael R. Koenig |
| City of Sheboygan | Mike Koenig Construction Co., Inc. |
| 828 Center Ave. | 3502 Behrens Parkway |
| Sheboygan, Wisconsin 53083 | Sheboygan, Wisconsin 53081 |

Nothing contained in this Article shall be construed to restrict the transmission of routine communications between representatives of the City and Mike Koenig Construction.

Article 27. Intent to be Bound

The City and Mike Koenig Construction each binds itself and its successors, executors, administrators, permitted assigns, legal representatives and, in the case of a partnership, its partners to the other party to this Agreement, and to the successors, executors, administrators, permitted assigns, legal representatives and partners of such other party in respect to all provisions of this Agreement.

Article 28. Force Majeure

Neither party shall be in default by reason of any failure in performance of this Agreement in accordance with reasonable control and without fault or negligence on their part. Such causes may include, but are not restricted to, acts of nature or the public enemy, acts of the government in either its sovereign or contractual capacity, fires, floods, epidemics, quarantine restrictions, strikes, freight embargoes, and unusually severe weather. In every case, the failure to perform must be beyond the reasonable control and without the fault or negligence of the party.

Article 29. Integration and Modification

This Agreement may be modified only by a written amendment signed by both parties hereto.

This Agreement consists of the following parts, each of which is as fully a part of this Agreement as if fully set out herein:

1. This Agreement and its Attachments
2. Any Written Amendment to the Agreement which may be delivered or issued after the Effective Date of the Agreement (including Change Orders)
3. Notice of Award
4. The Request for Bids (including all attachments)
5. All Addenda to the Request for Bids
6. Mike Koenig Construction's Bid Response (including the Items to be Attached)
7. All Other Submittals by Mike Koenig Construction
8. The Performance and Payment Bonds

(collectively "the Contract").

This Contract is the entire and integrated agreement between the City and Mike Koenig Construction regarding the subject matter of this Contract. It supersedes all prior and contemporaneous communications, representations and agreements that are not part of this Contract.

In resolving conflicts, errors, discrepancies and disputes concerning the Scope of Work to be performed by Mike Koenig Construction, the document expressing the greater quantity, quality, or other scope of work in question, or imposing the greater obligation upon Mike Koenig Construction and affording the greater right or remedy to the City shall govern. Otherwise, the documents shall be given precedence in the order set forth above.

Article 30. Non-Collusion

Mike Koenig Construction is certifying, under penalty of perjury, that to the best of its knowledge and belief:

1. The prices in its bid were arrived at independently, without collusion, consultation, communication, or agreement, for the purpose of restricting competition as to any other matter relating to such prices with any other bidder, or with any other competitor.

2. The prices quoted in its bid were not knowingly disclosed—directly or indirectly—by the bidder prior to bid opening.
3. No attempt was made to induce any other person, partnership, or corporation to submit or not submit a bid for the purpose of restricting competition.

Article 31. Other Provisions

1. **Material Safety Data Sheet.** If any item(s) on an order(s) resulting from this Agreement is a hazardous chemical, as defined under 29 C.F.R. 1910.1200, Mike Koenig Construction shall provide one (1) copy of a Material Safety Data Sheet for each item with the shipped container(s) and one (1) copy with the invoice(s).
2. **Advertising and News Releases.** Reference to or use of the City, or any of its departments, officials, or employees, for commercial promotion is prohibited. News releases pertaining to this procurement shall not be made without prior approval of the City. Release of broadcast e-mails pertaining to this procurement shall not be made without prior written authorization of the City.
3. **Foreign Corporation.** A foreign corporation (any corporation other than a Wisconsin corporation) which becomes a party to this Agreement is required to conform to all the requirements of Wis. Stat. 180 relating to a foreign corporation, and must possess a certificate of authority from the Wisconsin Department of Financial Institutions, unless the corporation is transacting business in interstate commerce or is otherwise exempt from the requirement of obtaining a certificate of authority.
4. **Authority.** Each person executing this Agreement on behalf of a party hereto represents and warrants to the other party: That the execution and delivery of this Agreement has been duly authorized, that the person or persons executing this Agreement have the full power, authority, and right to do so, and that such execution is sufficient and legally binding on such party to enable this Agreement to be enforceable in accordance with its terms.
5. **Definitions.**
 - a. **Final Acceptance:** The event that occurs when Mike Koenig Construction issues to the City or the City issues to Mike Koenig Construction a written statement that Mike Koenig Construction has completed all Punch List items, has made all necessary submittals to the City, and has satisfied all of its obligations under the Agreement.
 - b. **Final Inspection:** The inspection conducted by the City to determine what work must still be completed by Mike Koenig Construction in order for Completion of the Services to occur. After the Final Inspection, the City shall provide Mike Koenig Construction with a Punch List that Mike Koenig Construction must complete in order for Completion of the Services to occur.

- c. Final Payment: Payment by the City to Mike Koenig Construction after Completion of the Services the result of which is Mike Koenig Construction receiving all payments due under the terms of the Agreement for performing and completing the Services.

IN WITNESS WHEREOF, the parties hereto have caused this Agreement to be executed the day and year first written above.

CITY OF SHEBOYGAN, WISCONSIN

MIKE KOENIG CONSTRUCTION

BY: _____
Michael J. Vandersteen, Mayor

BY: _____

ATTEST: _____
Meredith DeBruin, City Clerk

ATTEST: _____

DATE: _____

DATE: _____

BID SUBMISSION FORM

We propose to remove and dispose of the existing windows, provide and completely install 41 new windows identified below at Fire Station # 1, Sheboygan, WI 53081 to include all labor, travel, tools, equipment, materials, disposal of old windows, all permits and bonding and complete restoration of any surfaces disturbed during the project as follows:

MANUFACTURER NAME: Pella

MANUFACTURER MODEL NAME/NUMBER: Impervia

TOTAL BASE BID: \$ \$124,900.00

The Base Bid above shall include all costs associated with the project including the rental or use of man-lifts to access the mounting locations if needed.

ADDENDUM INFORMATION (If Applicable)

Receipt of the addendum listed below is acknowledged and the proposals incorporate all requirements of this addendum:

Addendum No. 1 Dated 2/16/2019

_____ Dated _____

_____ Dated _____

If awarded the contract we would expect to begin installation of the system within 45 days following receipt of the City's Purchase Order and present the City with a completed project within 120 days following start of installation.

I agree to abide by all conditions of this Bid and certify that I am authorized to sign this Bid.

Complete Legal Name of Firm: Mike Koenig Construction Co., Inc.

Address: 3502 Behrens Parkway

Sheboygan, WI 53081

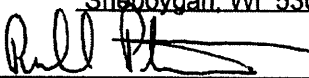
Signature: 

Name (type/print): Richard Peterson

Title: Project Manager

Telephone : (920) 457-0923 Fax: (920) 457-1024

Email richardp@mikekoenigconstruction.com

Date Signed 

Items to be attached:

- Manufacturer Cut Sheets**
- Manufacturer Warranties**
- Certification of installer training by window manufacturer**
- References**
- Energy efficiency certifications**



Proposal - Detailed

Pella Window and Door Showroom of Green Bay
 500 Pilgrim Way
 Green Bay, WI 54304
 Phone: (920) 435-3791 Fax: (920) 435-0377

Sales Rep Name: Coleman, Rob
 Sales Rep Phone: (920) 431-8921
 Sales Rep E-Mail: rcoleman@pellawi.com
 Sales Rep Fax:

| Customer Information | Project/Delivery Address | Order Information |
|---|---|--|
| 408 - Rob Coleman 500 Pilgrim Way GREEN BAY, WI 54304 Primary Phone: Mobile Phone: Fax Number: E-Mail: Contact Name: Great Plains #: Customer Number: 1003909138 Customer Account: 1001000724 | Sheboygan Fire Station #1 833 New York Ave Lot # Sheboygan, WI 53081 County: Owner Name: Owner Phone: | Quote Name: Impervia 2-22-19 Order Number: 408 Quote Number: 9923428 Order Type: Non-Installed Sales Wall Depth: Payment Terms: Net 30 Days Tax Code: Cust Delivery Date: None Quoted Date: 3/12/2018 Contracted Date: Booked Date: Customer PO #: |

| Line # | Location: | Attributes | Qty |
|--------|-----------|------------|-----|
|--------|-----------|------------|-----|

10 None Assigned

Impervia, Direct Set Fixed Frame Rectangle, 40 X 101, Brown

12

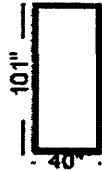

PK #
2028

1: 40101 Fixed Frame Direct Set
 Frame Size: 40 X 101
 General Information: Standard, Duracast®, Block. No Foam Insulated, 3", 1 5/16", 1 11/16"
 Exterior Color / Finish: Brown
 Interior Color / Finish: Brown
 Glass: Insulated Tempered Low-E SunDefense™ Low-E Insulating Glass Argon Non High Altitude
 Performance Information: U-Factor 0.26, SHGC 0.24, VLT 0.56, CPD PEL-N-127-02253-00001, Performance Class CW, PG 50, Calculated Positive DP Rating 50, Calculated Negative DP Rating 50, Year Rated 08
 Grille: No Grille,
 Wrapping Information: Standard Fin, No Exterior Trim, Pella Recommended Clearance, Perimeter Length = 282".

Viewed From Exterior
 Rough Opening: 40 - 1/2" X 101 - 1/2"

ROSJELJP004 - RS Loose Jamb Pine for 7 5/16 - 8 1/4 wall depth Qty 24
 TVAJA001 - VHI finish - jambs Qty 24

For more information regarding the finishing, maintenance, service and warranty of all Pella® products, visit the Pella® website at www.pella.com

| Line # | Location: | Attributes | |
|--------|-----------|------------|--|
|--------|-----------|------------|--|

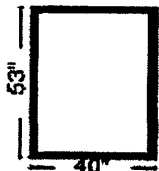
| | | | |
|----|---------------|--|-----------------------------|
| 15 | None Assigned | <p>Impervia, Direct Set Fixed Frame Rectangle, 40 X 53, Brown</p> <div style="display: flex; justify-content: space-between;"> <div style="width: 15%;">  <p>Viewed From Exterior Rough Opening: 40 - 1/2" X 53 - 1/2"</p> </div> <div style="width: 70%;"> <p>PK # 2028</p> <p>1: 4053 Fixed Frame Direct Set Frame Size: 40 X 53 General Information: Standard, Duracast®, Block, No Foam Insulated, 3", 1 5/16", 1 11/16" Exterior Color / Finish: Brown Interior Color / Finish: Brown Glass: Insulated Low-E SunDefense™ Low-E Insulating Glass Argon Non High Altitude Performance Information: U-Factor 0.27, SHGC 0.24, VLT 0.57, CPD PEL-N-127-02248-00003, Performance Class CW, PG 50, Calculated Positive DP Rating 50, Calculated Negative DP Rating 50, Year Rated 08 Grille: No Grille, Wrapping Information: Standard Fin, No Exterior Trim, Pella Recommended Clearance, Perimeter Length = 186".</p> </div> <div style="width: 15%; text-align: right;"> <p><u>Qty</u></p> <p>1</p> </div> </div> | |
| | | <p>ROSJELJP004 - RS Loose Jamb Pine for 7 5/16 - 8 1/4 wall depth</p> <p>TVAJA001 - VHI finish - jambs</p> | <p>Qty 16</p> <p>Qty 16</p> |

| Line # | Location: | Attributes | |
|--------|-----------|------------|--|
|--------|-----------|------------|--|

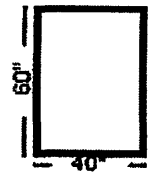
| | | | |
|----|---------------|--|-----------------------------|
| 20 | None Assigned | <p>Impervia, Direct Set Fixed Frame Rectangle, 40 X 60, Brown</p> <div style="display: flex; justify-content: space-between;"> <div style="width: 15%;">  <p>Viewed From Exterior Rough Opening: 40 - 1/2" X 60 - 1/2"</p> </div> <div style="width: 70%;"> <p>PK # 2028</p> <p>1: 4060 Fixed Frame Direct Set Frame Size: 40 X 60 General Information: Standard, Duracast®, Block, No Foam Insulated, 3", 1 5/16", 1 11/16" Exterior Color / Finish: Brown Interior Color / Finish: Brown Glass: Insulated Low-E SunDefense™ Low-E Insulating Glass Argon Non High Altitude Performance Information: U-Factor 0.27, SHGC 0.24, VLT 0.57, CPD PEL-N-127-02248-00003, Performance Class CW, PG 50, Calculated Positive DP Rating 50, Calculated Negative DP Rating 50, Year Rated 08 Grille: No Grille, Wrapping Information: Standard Fin, No Exterior Trim, Pella Recommended Clearance, Perimeter Length = 200".</p> </div> <div style="width: 15%; text-align: right;"> <p><u>Qty</u></p> <p>1</p> </div> </div> | |
| | | <p>ROSJELJP004 - RS Loose Jamb Pine for 7 5/16 - 8 1/4 wall depth</p> <p>TVAJA001 - VHI finish - jambs</p> | <p>Qty 17</p> <p>Qty 17</p> |

For more information regarding the finishing, maintenance, service and warranty of all Pella® products, visit the Pella® website at www.pella.com

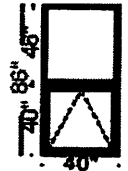
| Line # | Location: | Attributes | Qty |
|--------|---------------|--|-----|
| 25 | None Assigned | <p>Impervia, Large Awning, Impervia, Direct Set Fixed Frame Rectangle, 40 X 86, Brown</p>  <p>Viewed From Exterior Rough Opening: 40 - 1/2" X 86 - 1/2"</p> <p>PK # 2028</p> <p>1: Non-Standard Size Non-Standard Size Vent Awning Frame Size: 40 X 40 General Information: Standard, Duracast®, Block, No Foam Insulated, 3 1/4", 1 15/16" Exterior Color / Finish: Brown Interior Color / Finish: Brown Glass: Insulated Tempered Low-E SunDefense™ Low-E Insulating Glass Argon Non High Altitude Hardware Options: Top Pivot Hardware, Fold-Away Crank, Brown, No Limited Opening Hardware, Sill Screen: Full Screen, InView™ Performance Information: U-Factor 0.28, SHGC 0.20, VLT 0.45, CPD PEL-N-151-00730-00003, Performance Class LC, PG 50, Calculated Positive DP Rating 50, Calculated Negative DP Rating 50, Year Rated 11, Egress Not Applicable Grille: No Grille, Horizontal Mull 1: Factory Mull, Standard Joining Mullion, Frame To Frame Width- 0", Mull Design Pressure- 20 2: 4046 Fixed Frame Direct Set Frame Size: 40 X 46 General Information: Standard, Duracast®, Block, No Foam Insulated, 3", 1 11/16" Exterior Color / Finish: Brown Interior Color / Finish: Brown Glass: Insulated Tempered Spandrel Air Filled Non High Altitude Performance Information: CPD Not Rated, Performance Class CW, PG 50, Calculated Positive DP Rating 50, Calculated Negative DP Rating 50, Year Rated 08 Grille: No Grille, Wrapping Information: No Exterior Trim, Pella Recommended Clearance, Perimeter Length = 252", Glazing Pressure = 205.</p> <p>ROSJELJP004 - RS Loose Jamb Pine for 7 5/16 - 8 1/4 wall depth Qty 22 TVAJA001 - VHI finish - jambs Qty 22</p> | 27 |

| Line # | Location: | Attributes | Qty |
|--------|-----------|---|-----|
| 30 | | <p>Spandrel Glass for 1st Floor Door Transom</p> | 1 |

| Line # | Location: | Attributes | Qty |
|--------|---------------|--|-----|
| 35 | Install Clips | 00NL0000 - 6" Installation Clips (100) | 7 |

| Line # | Location: | Attributes | Qty |
|--------|----------------|--|-----|
| 40 | Frame Expander | <p>4" Frame Expander, Length: 96, Brown</p> <p>1: Accessory Frame Size: 1 X 1 General Information: 4" Frame Expander Exterior Color / Finish: Painted, Standard Enduraclad, Brown Wrapping Information: Perimeter Length = 0".</p> <p>PK # 2002</p> <p>Viewed From Exterior Rough Opening:</p> | 93 |

| Line # | Location: | Attributes | Qty |
|--------|----------------|---|-----|
| 45 | Frame Expander | <p>4" Frame Expander, Length: 144, Brown</p> <p>1: Accessory Frame Size: 1 X 1 General Information: 4" Frame Expander Exterior Color / Finish: Painted, Standard Enduraclad, Brown Wrapping Information: Perimeter Length = 0".</p> <p>PK # 2002</p> <p>Viewed From Exterior Rough Opening:</p> | 30 |

| Line # | Location: | Attributes | Qty |
|--------|-----------|--|-----|
| 50 | | Staright & Curved Historic Aluminum Brickmould & Clips | 1 |

Thank You For Your Interest In Pella® Products

PELLA WARRANTY:

Pella products are covered by Pella's limited warranties in effect at the time of sale. All applicable product warranties are incorporated into and become a part of this contract. Please see the warranties for complete details, taking special note of the two important notice sections regarding installation of Pella products and proper management of moisture within the wall system. Neither Pella Corporation nor the Seller will be bound by any other warranty unless specifically set out in this contract. However, Pella Corporation will not be liable for branch warranties which create obligations in addition to or obligations which are inconsistent with Pella written warranties.

Clear opening (egress) information does not take into consideration the addition of a Rolscreen [or any other accessory] to the product. You should consult your local building code to ensure your Pella products meet local egress requirements.

Per the manufacturer's limited warranty, unfinished mahogany exterior windows and doors must be finished upon receipt prior to installing and refinished annually, thereafter. Variations in wood grain, color, texture or natural characteristics are not covered under the limited warranty.

INSYNCTIVE PRODUCTS: In addition, Pella Insynctive Products are covered by the Pella Insynctive Products Software License Agreement and Pella Insynctive Products Privacy Policy in effect at the time of sale, which can be found at Insynctive.pella.com. By installing or using Your Insynctive Products you are acknowledging the Insynctive Software Agreement and Privacy Policy are part of the terms of sale.

ARBITRATION AND CLASS ACTION WAIVER ("ARBITRATION AGREEMENT")

YOU and Pella and its subsidiaries and the Pella Branded Distributor AGREE TO ARBITRATE DISPUTES ARISING OUT OF OR RELATING TO YOUR PELLA PRODUCTS (INCLUDES PELLA GOODS AND PELLA SERVICES) AND WAIVE THE RIGHT TO HAVE A COURT OR JURY DECIDE DISPUTES. YOU WAIVE ALL RIGHTS TO PROCEED AS A MEMBER OR REPRESENTATIVE OF A CLASS ACTION, INCLUDING CLASS ARBITRATION, REGARDING DISPUTES ARISING OUT OF OR RELATING TO YOUR PELLA PRODUCTS. You may opt out of this Arbitration Agreement by providing notice to Pella no later than ninety (90) calendar days from the date You purchased or otherwise took ownership of Your Pella Goods. To opt out, You must send notice by e-mail to pellawebsupport@pella.com, with the subject line: "Arbitration Opt Out" or by calling (877) 473-5527. Opting out of the Arbitration Agreement will not affect the coverage provided by any applicable limited warranty pertaining to Your Pella Products. For complete information, including the full terms and conditions of this Arbitration Agreement, which are incorporated herein by reference, please visit www.pella.com/arbitration or e-mail to pellawebsupport@pella.com, with the subject line: "Arbitration Details" or call (877) 473-5527. D'ARBITRAGE ET RENONCIATION AU RECOURS COLLECTIF ("convention d'arbitrage") EN FRANÇAIS SEE PELLA.COM/ARBITRATION. DE ARBITRAJE Y RENUNCIA COLECTIVA ("acuerdo de arbitraje") EN ESPAÑOL VER PELLA.COM/ARBITRATION.

Product Performance Information:

U-Factor, Solar Heat Gain Coefficient (SHGC), and Visible Light Transmittance (VLT) are certified by the National Fenestration Rating Council (NFRC). Manufacturer stipulates that these ratings conform to applicable NFRC procedures for determining whole product performance. NFRC ratings are determined for a fixed set of environmental conditions and a specific product size. NFRC does not recommend any products and does not warrant the suitability of any product for any specific use.

Design Pressure (DP), Performance Class, and Performance Grade (PG) are certified by a third party organization, in many cases the Window and Door Manufacturers Association (WDMA). The certification requires the performance of at least one product of the product line to be tested in accordance with the applicable performance standards and verified by an independent party. The certification indicates that the product(s) of the product line passed the applicable tests. The certification does not apply to mulled and/or product combinations unless noted. Actual product results will vary and change over the products life.

For more performance information along with information on Florida Product Approval System (FPAS) Number and Texas Dept. of Insurance (TDI) number go to www.pella.com/performance.

BRANCH WARRANTY:

For more information regarding the finishing, maintenance, service and warranty of all Pella® products, visit the Pella® website at www.pella.com

NOTICE OF LIEN RIGHTS

As required by the Wisconsin construction lien law, VerHalen, Inc DBA Pella Windows and Doors of Wisconsin hereby notifies owner that persons or companies furnishing labor or materials for the construction on owner's land may have lien rights on owner's land and buildings if not paid. Those entitled to lien rights, in addition to VerHalen, Inc DBA Pella Windows and Doors of Wisconsin, are those who contract directly with the owner or those who give the owner notice within 60 days after they first furnish labor or materials for the construction. Accordingly, owner probably will receive notices from those who furnish labor or materials for the construction and should give a copy of each notice received to the owner's mortgage lender, if any. VerHalen, Inc DBA Pella Windows and Doors of Wisconsin agrees to cooperate with the owner and the owner's lender, if any, to see that all potential lien claimants are duly paid.

TERMS & CONDITIONS:

PERFORMANCE: Where no specific date is fixed we shall be allowed reasonable time to make delivery of the materials and perform the work.

DAMAGE, LOSS, DELAY OR DEFAULT THROUGH CAUSES BEYOND OUR CONTROL: We shall not be responsible for default, damage, loss or delay in performance due to labor trouble, fires, accidents, floods, collapse or other causes beyond our control, or due to shortages of materials or transportation facilities resulting from war, national or local emergency, riots, governmental priorities, embargoes and like conditions and regulations. Any and all loss of, or damage to our materials erected or stored on the premises, not caused by us, shall be repaired and replaced by us and the additional cost thereof shall be borne by the purchaser.

WORKING CONDITIONS AND FACILITIES TO BE SUPPLIED BY THE PURCHASER: The purchaser shall make all work surfaces, on which materials are to be supplied, available for work at one time so that the work shall not be interrupted; shall provide surfaces that are clean, dry and in an accessible condition, shall at his own expense cause all obstructions to our work to be removed; shall additionally bear the cost of sending our men to the job, on his notification, before surfaces are ready for the application of our materials, or expense due to any delay during the progress of the work not caused by us; shall allow us free and reasonable use of light, heat, water and power, and the use of available elevators, hoists and other facilities.

DELIVERY: When materials are quoted on the basis of delivery to the jobsite, we provide delivery assistance to the customer's garage only.

INSURANCE: We carry public liability, property damage and workmen's compensation insurance and consequently will not honor any charges against us for such similar coverage. Any expense incurred by us for insurance or bond to cover our liability under any "hold harmless" or "indemnity" clause or clause of a similar nature in any contract, specifications, letter of acceptance or notice submitted by you or your contractors which in any way requires us to assume any liability which is not imposed on us by law, shall be paid by you.

CHANGES IN PLANS OR SPECIFICATIONS: No credit or allowance shall be granted for alterations or modifications in work or materials, unless such credit or allowance has been agreed to by us in writing before such alterations or modifications are made.

GLAZING: Attention is directed to the Consumer Product Safety Act and the Federal Regulation for "Architectural Glazing Materials (16 CFR 1201)." THIS LAW SPECIFIES WHERE THE USE OF TEMPERED GLASS IS MANDATORY. In any instances of claims arising from the use of non-tempered glass, it will be the sole liability of the contractor or customer who accepted the glass as specified in our proposal that the use of such non-tempered glass is not prohibited by law, and that this glass will be used in areas in which non-tempered glass is allowable. Distortion in tempered glass is common and is not considered a defect.

TAXES: Any sales, excise, processing or any other direct tax imposed upon the distributor, sale or application of materials supplied in accordance with this proposal shall be added to the proposal price.

CONSEQUENTIAL DAMAGE: Seller shall not be liable for any direct, indirect or consequential damage or loss for any reasons, including but not limited to: any defect or defects in materials, improper installation, or breakage, bursting leakage.

ACCEPTANCE OF WORK AND MATERIALS: The Customer shall immediately upon delivery inspect all material. All work performed and materials supplied under this Proposal shall be deemed to comply with all terms of the Proposal unless Seller is notified to the contrary within seven (7) days following delivery.

AUTHORIZATION TO USE PHOTOGRAPHS AND/OR PROJECT DETAILS: I hereby authorize Pella Corporation, its affiliates and/or subsidiaries to use, reproduce, and/or publish photographs and/or video that may pertain to me and my project, including materials described below, without compensation. I understand that this material may be used in various communications (e.g. Website, e-newsletters, promotional materials, etc).

Consequently, the Corporation may publish materials, photographs, and/or make reference to the project in a manner that the Corporation or project sponsor deems appropriate.

DEFAULTS: If the customer fails to pay pursuant to the terms of this accepted proposal, the Customer agrees to pay all reasonable attorney fees and costs (of whatever nature) incurred by the Seller to obtain collection.

CANCELLATIONS AND/OR CHANGES: All sales are final. Product is ordered based on customer specification and approval via the signed contract.

WARRANTY: Pella products are covered by Pella's limited warranties in effect at the time of sale. All applicable product warranties are incorporated into and become a part of this contract. Please see

For more information regarding the finishing, maintenance, service and warranty of all Pella® products, visit the Pella® website at www.pella.com

Customer: 408 - Rob Coleman

Project Name: Sheboygan Fire Station #1

Quote Number: 9923428

the warranties for complete details, taking special note of the two important notice sections regarding installation of Pella products and proper management of moisture within the wall system. Neither Pella Corporation nor VerHalén, Inc. DBA Pella Windows and Doors of Wisconsin will be bound by any other warranty unless specifically set out in this contract. However, Pella Corporation will not be liable for branch warranties which create obligations in addition to or obligations which are inconsistent with Pella written warranties.

Clear opening (egress) information does not take into consideration the addition of a Rolscreen (or any other accessory) to the product. You should consult your local building code to ensure your Pella products meet local egress requirements.

For more information regarding the finishing, maintenance, service and warranty of all Pella® products, visit the Pella® website at www.pella.com

Printed on 2/22/2019

Detailed Proposal

Page 8 of 9

PRODUCT PERFORMANCE

GLAZING
Center of Glass Performance

CENTER OF GLASS PERFORMANCE COMPARISON GUIDE

This chart is an overview of the typical glass types that are available from Pella. The types of glass and the glass thickness vary by brand. For complete Glazing Performance data, including Obscure and High Altitude₂ glazing, please go to the appropriate product section of www.PellaADM.com.

| TYPE OF GLAZING | Glass Thickness | U-Factor | Solar Heat Gain Coefficient (SHGC) | Shading Coefficient (SC) | Relative Heat Gain | % Visible Light Transmission | Inside Glass Surface Temp (°F) | % Relative Humidity @70°F when condensation appears on room side | % UV Transmission | LBL Damage Function | Low-E Coating on Surfaces # |
|---|------------------|----------|------------------------------------|--------------------------|--------------------|------------------------------|--------------------------------|--|-------------------|---------------------|-----------------------------|
| Dual-Pane Insulating Glass, Argon filled 1 1/16" overall thickness | | | | | | | | | | | |
| Clear (air filled) | 3mm ₁ | 0.48 | 0.78 | 0.89 | 186 | 82 | 44 | 39 | 58 | 0.61 | |
| SunDefense™ Low-E | 3mm ₁ | 0.24 | 0.27 | 0.31 | 66 | 65 | 56 | 61 | 5 | 0.21 | 2 |
| Advanced Low-E | 3mm ₁ | 0.25 | 0.37 | 0.42 | 88 | 70 | 56 | 61 | 14 | 0.31 | 2 |
| AdvancedComfort Low-E | 3mm ₁ | 0.20 | 0.36 | 0.42 | 86 | 69 | 47 | 44 | 14 | 0.31 | 2,4 |
| NaturalSun Low-E | 3mm ₁ | 0.26 | 0.68 | 0.79 | 161 | 79 | 55 | 59 | 29 | 0.42 | 3 or 2* |
| Bronze Advanced Low-E | 5mm/3mm | 0.25 | 0.33 | 0.38 | 79 | 45 | 56 | 61 | 7 | 0.19 | 3 |
| Gray Advanced Low-E | 5mm/3mm | 0.25 | 0.30 | 0.34 | 73 | 39 | 56 | 61 | 7 | 0.18 | 3 |
| Green Advanced Low-E | 5mm/3mm | 0.25 | 0.32 | 0.37 | 77 | 55 | 56 | 61 | 5 | 0.19 | 3 |
| Advanced Laminated Low-E | 3mm/6mm | 0.31 | 0.37 | 0.42 | 89 | 68 | 53 | 55 | 0 | 0.20 | 2 or 3** |
| SunDefense™ Laminated Low-E | 3mm/6mm | 0.31 | 0.28 | 0.32 | 68 | 63 | 53 | 55 | 0 | 0.16 | 2 or 3** |
| Dual-Pane Insulating Glass, Argon filled 1" overall thickness | | | | | | | | | | | |
| Clear (air filled) | 6mm | 0.49 | 0.75 | 0.87 | 181 | 82 | 46 | 41 | 54 | 0.58 | |
| SunDefense Low-E | 6mm | 0.25 | 0.27 | 0.31 | 65 | 63 | 56 | 61 | 4 | 0.20 | 2 |
| Advanced Low-E | 6mm | 0.25 | 0.35 | 0.41 | 84 | 68 | 56 | 61 | 13 | 0.30 | 2 |
| AdvancedComfort Low-E | 6mm | 0.20 | 0.35 | 0.40 | 82 | 66 | 47 | 44 | 12 | 0.29 | 2,4 |
| NaturalSun Low-E | 6mm | 0.26 | 0.64 | 0.74 | 150 | 77 | 55 | 59 | 24 | 0.38 | 3 or 2* |
| Bronze Advanced Low-E | 6mm | 0.25 | 0.30 | 0.34 | 71 | 40 | 56 | 61 | 6 | 0.16 | 3 |
| Gray Advanced Low-E | 6mm | 0.25 | 0.27 | 0.31 | 64 | 34 | 56 | 61 | 6 | 0.16 | 3 |
| Green Advanced Low-E | 6mm | 0.25 | 0.29 | 0.33 | 69 | 51 | 56 | 61 | 4 | 0.17 | 3 |
| Advanced Laminated Low-E | 5mm/10mm | 0.25 | 0.36 | 0.41 | 85 | 67 | 56 | 61 | 0 | 0.17 | 2 or 3** |
| SunDefense™ Laminated Low-E | 5mm/10mm | 0.24 | 0.27 | 0.31 | 66 | 62 | 56 | 61 | 0 | 0.14 | 2 or 3** |
| 1" Triple-Pane Insulating Glass—Pella 250 Series | | | | | | | | | | | |
| Advanced Low-E | 3mm | 0.16 | 0.31 | 0.36 | 74 | 55 | 60 | 71 | 4 | 0.19 | 2, 5 |
| NaturalSun Low-E | 3mm | 0.17 | 0.56 | 0.64 | 131 | 70 | 60 | 71 | 13 | 0.29 | 2, 5 |
| Advanced Low-E | 4mm | 0.19 | 0.31 | 0.35 | 73 | 53 | 59 | 68 | 4 | 0.19 | 2, 5 |
| NaturalSun Low-E | 4mm | 0.20 | 0.54 | 0.62 | 127 | 69 | 59 | 68 | 12 | 0.28 | 2, 5 |
| 1-1/4" Triple-Pane Insulating Glass—Pella 350 Series | | | | | | | | | | | |
| Advanced Low-E | 3mm ₂ | 0.13 | 0.31 | 0.36 | 73 | 55 | 62 | 76 | 4 | 0.19 | 2, 5 |
| NaturalSun Low-E | 3mm ₂ | 0.14 | 0.56 | 0.64 | 131 | 70 | 62 | 76 | 13 | 0.29 | 2 |

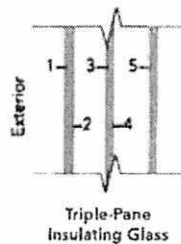
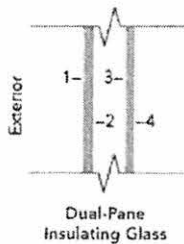

(1) Performance of products with 3/4", 1 3/16" IG or 2.5mm glass is within 10% of those stated for 3mm glass.
 (2) 4mm and 5mm glass construction perform similar to 3mm within 10%.

* Wood products, Pella® Impervia and Pella 350 Series; Side 3, Pella 250 Series and Encompass by Pella™; Side 2
 ** Varies by product



UNIT SECTIONS
Block Frame



FIXED FRAME DIRECT SET

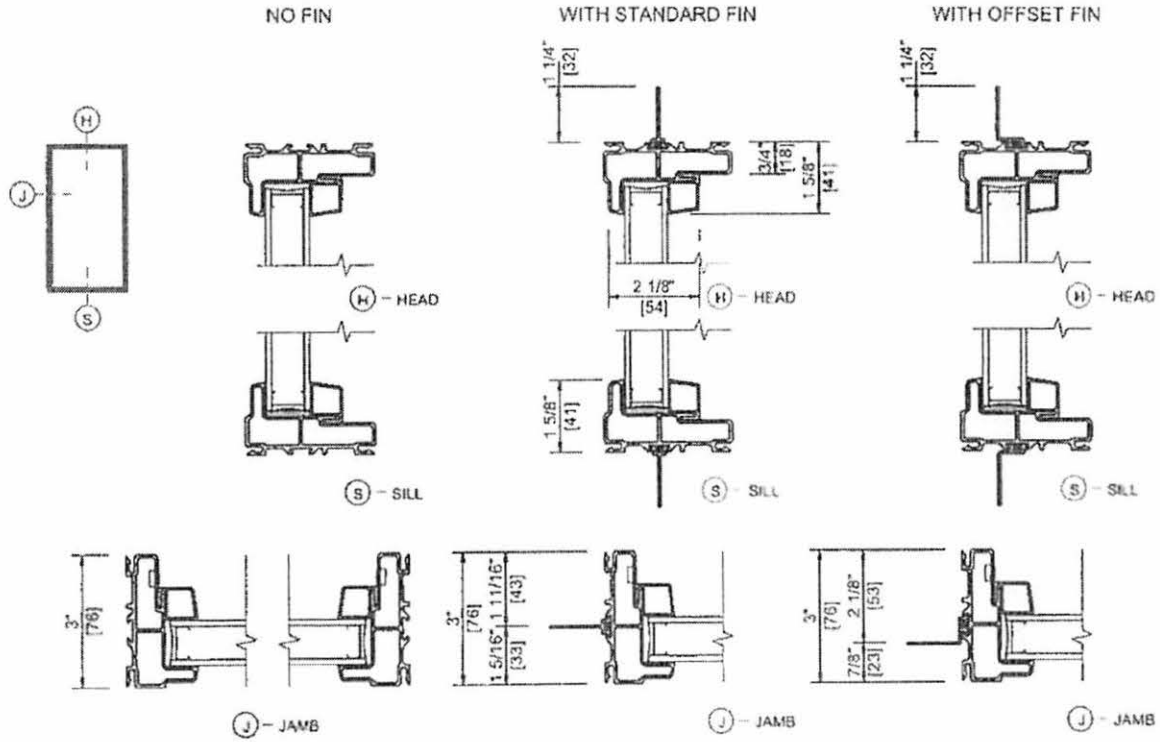

TYPICAL JOINING MULLIONS

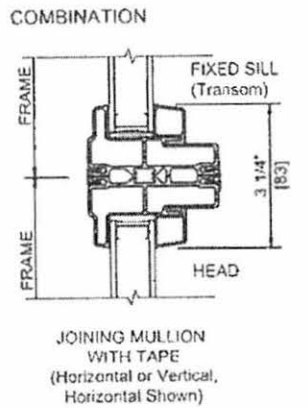

Scale 3" = 1' 0"

All dimensions are approximate.

Factory-assembled integral mullions have a 3" overall frame width. Combination joining mullions are 3-1/4" frame width.

See the Installation and Performance section at PellaADM.com for mullion applications and structural limitations



UNIT SECTIONS

Large Awning Block Frame and Integral Nailing Fin



AWNING

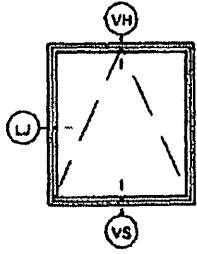

STANDARD
BLOCK FRAME

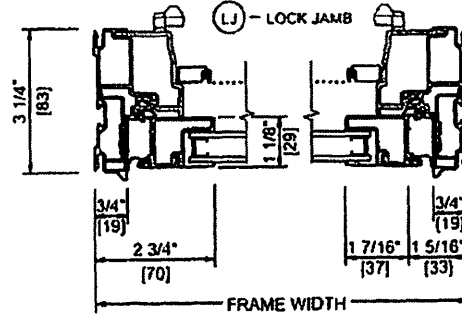
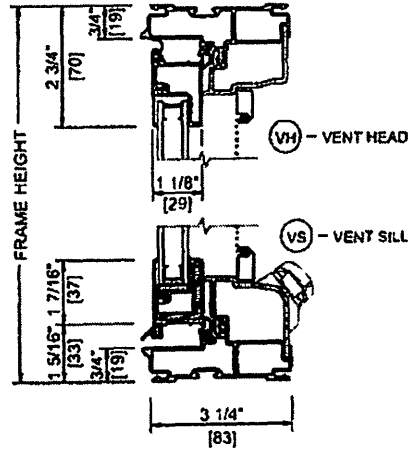

INTEGRAL
NAILING FIN

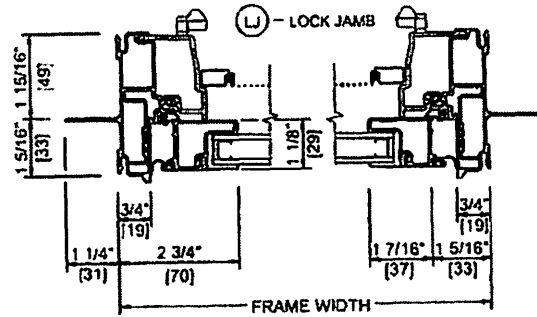
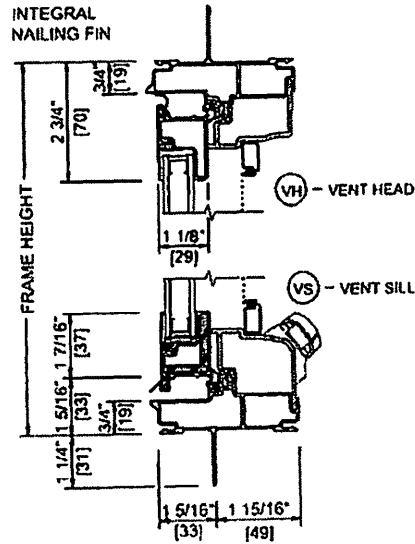

Scale 3" = 1' 0"

All dimensions are approximate.



**PELLA® IMPERVIA®
LIMITED LIFETIME WARRANTY AND
PELLA FIBERGLASS-RESIN
20/10 LIMITED WARRANTY**

Congratulations on choosing Pella Impervia and/or Pella fiberglass-resin window and door products to protect and beautify your home. These superior-quality windows and patio doors have been designed to give you years of comfort.

IMPORTANT NOTICE: Read this entire Pella Limited Warranty and Limitation of Liability ("Limited Warranty") before purchasing or installing this product. Refer to the *Pella Impervia Owner's Manual* for the required care and maintenance of your Pella products (Owner's Manuals available on pella.com). By installing or using this product, you are acknowledging that this Limited Warranty is part of the terms of sale.

LIMITED LIFETIME WARRANTIES FOR PRODUCTS INSTALLED IN OWNER-OCCUPIED SINGLE-FAMILY HOMES EXCLUDE PELLA IMPERVIA'S DURACAST® MATERIAL FOR RECTANGULAR PRODUCTS INSTALLED IN OTHER THAN OWNER-OCCUPIED SINGLE-FAMILY HOMES

This Limited Warranty applies only to Pella Impervia and Pella fiberglass-resin products ("Covered Pella Products"). Pella makes the following exclusive express Limited Warranties for Pella Impervia and Pella fiberglass-resin products installed in owner-occupied single-family homes within the United States and Canada, subject to the stated conditions and limitations.

Nontransferable Limited Lifetime Warranty on Pella Impervia's Duracast Material.

Pella warrants that its Duracast material, which makes up the rectangular frame, sash or panel parts of Pella Impervia window and door products, will be free from cracking, splitting, corroding and warping for as long as you own your home. If Pella is given proper notice of a defect in the Duracast materials of a Pella Impervia rectangular window or door product, Pella shall, at its sole option: 1) repair or replace the defective part(s) or product(s) (with cost of labor included only within two [2] years of the date of sale by Pella or its authorized dealer) or 2) refund the original purchase price. This Limited Lifetime Warranty is provided to the original homeowner and may not be assigned or transferred. The Duracast Limited Lifetime Warranty does not cover the paint finish applied to the Duracast material, which is covered under the transferable ten-year (10-year) warranty on material and workmanship found below. In addition, the Transferable Ten-Year (10-Year) Limited Warranty on materials and workmanship replaces the Limited Lifetime Warranty on Pella's Duracast® material when you transfer ownership of your single-family home or cease to occupy your home.

20/10 LIMITED WARRANTY ON PELLA'S FIBERGLASS-RESIN MATERIAL FOR NONRECTANGULAR PRODUCTS INSTALLED IN OWNER-OCCUPIED SINGLE-FAMILY HOMES, RESIDENTIAL AND COMMERCIAL APPLICATIONS

Pella's Fiberglass-Resin Material (Non-Duracast Material) — Transferable Ten-Year (10-Year) Limited Warranty. Pella warrants that its fiberglass-resin material, which makes up the frame and glass stops of the nonrectangular Special Shapes (i.e., half-circles, triangles, etc.), shall be free of defects in material or workmanship that significantly impair their proper operation and function for ten (10) years from the date of sale by Pella or its authorized dealer. If Pella is given notice of a defect in materials or workmanship of a Pella product occurring within ten (10) years from the date of sale by Pella or its authorized dealer, Pella shall, at its sole option: 1) repair or replace the defective part(s) or product(s) (with cost of labor included only within two [2] years of the date of sale by Pella or its authorized dealer) or 2) refund the original purchase price. This Limited 10-Year Warranty may be transferred.

The following applies to the Pella Impervia® Limited Lifetime Warranty and the Pella Fiberglass-Resin 20/10 Limited Warranty:

TRANSFERABLE LIMITED WARRANTIES FOR NONGLASS MATERIALS, WORKMANSHIP AND GLASS FOR DURACAST PRODUCTS INSTALLED IN RESIDENTIAL AND COMMERCIAL APPLICATIONS

Nonglass Materials and Workmanship. Transferable Ten-Year (10-Year) Limited Warranty.

This Transferable Ten-Year (10-Year) Limited Warranty applies to the Duracast material not installed in owner-occupied single-family homes, and automatically replaces the Duracast Material Nontransferable Limited Lifetime Warranty for products installed in owner-occupied single-family homes, upon Buyer's transfer of ownership of the single-family home or at such time that the Buyer ceases to occupy the home within ten (10) years of the date of sale by Pella or its authorized dealer. Pella® warrants that all nonglass components of its Covered Pella Products shall be free of manufacturing defects in material or workmanship that significantly impair their proper operation and function for ten (10) years from the date of sale by Pella or its authorized dealer. If Pella is given notice of a defect in materials or workmanship of a Pella Impervia product occurring within ten (10) years from the date of sale by Pella or its authorized dealer, Pella shall, at its sole option: 1) repair or replace the defective part(s) or product(s) (with cost of labor included only within two [2] years of the date of sale by Pella or its authorized dealer) or 2) refund the original purchase price. This Ten-Year (10-Year) Limited Warranty may be transferred.

Nonlaminated Glass. Transferable Twenty-Year (20-Year) Limited Warranty.

Pella warrants that the glass in Pella products shall be free from premature failure or permanent material obstruction of vision due to a failure of the glass seal for twenty (20) years from the date of sale by Pella or its authorized dealer. If Pella is given notice of a glass defect occurring within twenty (20) years of the date of sale by Pella or its authorized dealer, Pella shall, at its sole option: 1) repair or replace the defective glass (with cost of labor included only within two [2] years of the date of sale by Pella or its authorized dealer) or 2) refund the original purchase price.

Exterior Surround Made with AZEK® Trim. Transferable Twenty-Five-Year (25-Year) Limited Warranty.

Pella warrants that the exterior surround, made with AZEK Trim, shall be free of rot, corrosion, delaminating or excessive swelling from moisture for twenty-five (25) years from the date of sale by Pella or its authorized dealer. Product must be installed and painted (finished) in accordance with Pella's Installation Instructions. If Pella is given notice of a defect occurring within twenty-five (25) years of the date of sale by Pella or its authorized dealer, Pella shall, at its sole option: 1) repair or replace the defective component(s) (with cost of labor included only within two [2] years of the date of sale by Pella or its authorized dealer) or 2) refund the original purchase price of the defective parts. This warranty does not cover the painted finishes or coating applied to the product by the original purchaser or any third party.

LIMITED WARRANTIES ON FRAMES USED ON BAY AND BOW WINDOWS FOR PELLA IMPERVIA PRODUCTS INSTALLED IN OWNER-OCCUPIED SINGLE FAMILY HOMES, RESIDENTIAL AND COMMERCIAL APPLICATIONS*

Nonglass Components. Transferable Ten-Year (10-Year) Limited Warranty.

Pella warrants that the nonglass components of its Covered Pella Products shall be free of manufacturing defects in material or workmanship or termite damage that significantly impair their proper operation and function for ten (10) years from the date of sale by Pella or its authorized dealer. If Pella is given notice of a defect in materials or workmanship occurring within ten (10) years from the date of sale by Pella or its authorized dealer, Pella shall, at its sole option: 1) repair or replace the defective part(s) or product(s) (with cost of labor included only within two [2] years of the date of sale by Pella or its authorized dealer) or 2) refund the original purchase price. This Limited Warranty on Nonglass Components does not apply to nonpainted hardware finishes.

Interior Factory Finish. Two-Year (2-Year) Limited Warranty.

Pella warrants that all factory-applied interior paint and stain finishes to bay/bow frames by Pella Corporation will be free of any "Finish Defect" for a period of two (2) years from the date of sale by Pella or a Pella-authorized dealer. Pella products with factory-applied interior primer only are excluded from the interior finish Limited Warranty. A Finish Defect includes cracking, peeling, checking, delaminating, blistering, flaking, chalking in excess of a numerical rating of six (when measured in accordance with the standard practice specified in ASTM D659) or fading or change in color in excess of five "E" units (NBS), calculated in accordance with ASTM 2244. If Pella is given notice of such Finish Defect within two (2) years from the date of sale, Pella shall, at its sole option: 1) refinish the product (the finish may not necessarily be the same finish as originally applied to the product), 2) furnish labor to replace or repair any defective finish workmanship (and provide replacement materials if Pella determines such materials are necessary to make the repairs) or 3) refund the original purchase price of the defective item in question. This Finish Warranty is provided to the original Buyer and may not be assigned or transferred, although the limitations of liability set forth herein apply to all sales and persons.

*Bay and bow windows for Pella Impervia made with wood frame.

CONDITIONS APPLICABLE TO ALL LIMITED WARRANTIES

Limitation of Warranty.

FAILURE TO COMPLY WITH PELLA® INSTALLATION AND MAINTENANCE INSTRUCTIONS VOIDS ALL WARRANTIES UNLESS IT IS CLEARLY ESTABLISHED BY THE BUYER OR USER OF THE PRODUCT THAT THE DEFECT OR FAILURE IS UNRELATED TO SUCH NONCOMPLIANCE. This Limited Warranty does not extend to the use of Covered Pella Products under abnormal conditions, conditions that exceed the stated performance parameters of the product as provided on the product labeling and in the Pella Architectural Design Manual, or under conditions not reasonably foreseeable to, or beyond the control of, Pella. Buyer and User assume all risk of any such use. This Limited Warranty is the exclusive warranty for the Covered Pella Products. **NEITHER PELLA NOR SELLER MAKE ANY OTHER WARRANTIES, EXPRESS OR IMPLIED, INCLUDING ANY IMPLIED WARRANTIES OF MERCHANTABILITY, FITNESS FOR A PARTICULAR PURPOSE OR OTHERWISE.** This disclaimer of implied warranties may be limited or ineffective if you are a consumer, as that term is defined by the Magnuson Moss Act, 15 U.S.C. § 2301, in which case the duration of any implied warranties shall be two (2) years from the date of sale by Pella or its authorized dealer. Some states do not allow limitations on how long an implied warranty lasts for consumers, so the above limitation may not apply to you, in which event the manner of presenting any claim thereon shall be the same as provided in the express warranties stated herein. This Limited Warranty gives you specific legal rights, and you may have additional rights, which vary from state to state.

Allocation of Risks of Pella Product Performance.

Because all construction must anticipate some water infiltration, it is important that the wall system be designed and constructed to properly manage moisture. Pella Corporation is not responsible for claims or damages caused by anticipated or unanticipated water infiltration; deficiencies in building design, construction and maintenance; failure to install Pella products in accordance with Pella Installation Instructions; or the use of Pella products in barrier wall systems, which do not allow for proper management of moisture within the wall system (see the following). The determination of the suitability of all building components, including the use of Pella products, as well as the design and installation of flashing and sealing systems, is the responsibility of Buyer or User, architect, contractor, installer or other construction professional, and is not the responsibility of Pella. All risks related to building design and construction, or the maintenance, installation and use of Pella products, shall be assumed by Buyer and/or User.

IMPORTANT NOTICE: Pella products should not be used in barrier wall systems, which do not allow for proper management of moisture within the wall systems, such as Exterior Insulation Finish Systems (EIFS) (also known as synthetic stucco) or similar systems. Except in the states of California, New Mexico, Arizona, Nevada, Utah and Colorado, Pella makes no warranty of any kind on and assumes no responsibility for Pella windows and doors installed in barrier wall systems. In the states listed above, the installation of Pella products in EIFS or similar barrier systems must be in accordance with Pella's instructions for that type of construction.

Limitation of Liability.

This Limited Warranty sets forth the maximum liability for our products. **IN NO EVENT (INCLUDING WHERE THIS LIMITED WARRANTY IS DEEMED NOT TO APPLY TO THE SALE OR PRODUCT IN QUESTION) SHALL PELLA OR SELLER BE LIABLE FOR ANY INCIDENTAL, CONSEQUENTIAL OR SPECIAL DAMAGES RESULTING FROM THE SALE, INSTALLATION OR USE OF ANY PELLA® PRODUCTS.** Some states do not allow the exclusion or limitation of incidental or consequential damages for consumers, so the above limitation or exclusion may not apply to you.

Limitation of Remedy.

THE EXCLUSIVE REMEDY OF THE BUYER OR USER, AND THE SOLE LIABILITY OF PELLA AND SELLER, FOR ANY AND ALL CLAIMS, LOSSES, INJURIES OR DAMAGES (INCLUDING CLAIMS BASED ON BREACH OF WARRANTY, CONTRACT, NEGLIGENCE, TORT, STRICT LIABILITY OR OTHERWISE) RESULTING FROM THE SALE, INSTALLATION OR USE OF THESE PRODUCTS, SHALL BE, AT THE OPTION OF PELLA, THE REPAIR OR REPLACEMENT OF THE PRODUCT OR THE RETURN OF THE ORIGINAL PURCHASE PRICE OF THE PRODUCT, AS PROVIDED HEREIN. IN NO EVENT SHALL THE LIABILITY OF PELLA OR SELLER EXCEED THE PRICE PAID FOR THE PRODUCT. Replacement products shall be a reasonably similar current product and may not exactly match the original. Even where Pella chooses to repair or replace product within two (2) years of the date of sale, the costs covered by this warranty do not include any labor or material costs associated with finishing space surrounding or adjacent to the repaired or replaced product, including furnishing any trim or other carpentry work. Replacement product provided pursuant to this Limited Warranty shall be subject to the applicable Pella product Limited Warranty only for the remainder of the original warranty period on the product being replaced. If Pella or Seller provides any of the remedies identified in the Limited Warranties above (i.e., repair, replacement of product or refund of the purchase price), then Buyer and/or User agrees that this limitation of remedy shall not have failed of its essential purpose.

DISCLAIMER — WHAT THIS LIMITED WARRANTY DOES NOT COVER

Pella is not responsible for or makes no warranty as to:

1) Product failure, loss or damage due to:

- Normal wear and tear.
- Improper storage, handling, installation, finishing, use, modification or maintenance.
- Mechanical abrasion to finishes.
- Non-factory-applied finishes, applied sealants or caulking. Finishes applied by your local dealer/contractor are not covered by this warranty.
- Damage caused by failing to finish your bay or bow frames in a timely manner to protect them from UV rays and the elements.
- Nonfactory finishing, repairs or modifications performed by anyone other than Seller (or one of its subcontractors).
- Finishes of non-Pella® products.
- The buyer's choice of finish, or whether the chosen finish on bay or bow frames is a match to other or existing finishes.
- Structural settlement, movement or vibration.
- Product or finishes exposed to excessive localized heat, high-moisture environments (including pools, hot tubs and greenhouses) or water leakage.
- Finish failure or any other losses arising from defects in the existing structure.
- Interior prime finish on bay or bow frames.
- Normal wear, fading or discoloration of finish from product usage, age or exposure to direct sunlight.
- Acts of God.
- Acid rain or other corrosive elements.
- Installation of anything other than standard factory-installed glass in Duracast® frames.
- Accidents, including accidental glass breakage.
- Application of after-market window films to glass surfaces.
- Damage caused by inappropriate finishes, solvents, brickwash or cleaning chemicals.
- Glass breakage, not the fault of Pella, that results in seal failure.
- Damage to glass as a result of improper use or application.
- Damage caused by high in-home humidity (condensation, frost and mold).
- Accident; misuse; abuse; alterations; improper handling operation or cleaning.
- Products subjected to conditions outside product design limitations.
- Improperly installed security systems.
- Products with modifications that are not approved by Pella Corporation.
- Hardware finishes.
- Ripping, tearing or other damage not the fault of Pella to window screens associated with wear and tear through product use.
- Insects, including grasshoppers (with the exception of coverage for termites on bay or bow frames).
- Finishing or modifying the structure containing repaired or replaced product.
- The purchase, damage, repair or replacement of non-Pella products.
- Products that have not been paid for in full.

2) Minor imperfections in the product:

- Minor imperfections in glass that do not affect the product's structural integrity or significantly obscure vision.
- Minor variations in glass color.
- Variations in wood grain, color, texture or natural characteristics on bay or bow frames.

3) Installation inconsistent with Pella Installation Instructions:

- Damage resulting in whole or in part from installation inconsistent with Pella's Installation Instructions.
- Altered or reinstalled products.
- Products used in nonvertical glazing applications.
- Combinations not built by Pella or not built in accordance with Pella's recommendations for mulling and combining Pella products.

WDMA Hallmark Certification.

Pella® products labeled with the Window & Door Manufacturers Association (WDMA) Hallmark Certification are tested in accordance with applicable WDMA performance standards, which require products to be tested for air infiltration, water infiltration and structural performance. The WDMA certification standards measure the performance of a single sample of the product at the time of manufacture. Performance of Pella products, as measured by the WDMA standards, will change over time depending upon the conditions of use. For details on Hallmark Certification, go to WDMA.com. All Hallmark Certification performance ratings apply to individual products only. Pella makes no claims as to the overall performance of mullied and/or product combinations.

NFRC Standards.

Pella® products labeled with the National Fenestration Rating Council (NFRC) Energy Performance label are tested in accordance with NFRC standards. NFRC ratings are based on a combination of computer simulations and physical testing of product samples. For details on NFRC Energy Performance ratings, go to NFRC.org.

Argon.

For Pella products labeled as having Low-E insulating glass with argon, Pella injects argon at the time of manufacture. No warranty is made as to the amount or percentage of argon present in the insulating glass. It is known that argon within insulating glass dissipates over time. The manner of use and conditions of installation of the product will affect the rate of dissipation of argon out of the insulating glass. Pella makes no warranty regarding the rate of dissipation of argon or the amount of argon remaining in the window at any time after manufacture.

Prompt Notice of Claim.

Within the warranty period, Buyer or User shall promptly notify Pella, and in no case more than one (1) year after any defect or other basis of a claim covered by this Limited Warranty is discovered or should have been discovered. Any claims otherwise covered by the foregoing warranties, but for which Pella did not receive notice within one (1) year from the time the problem first became known, shall be barred.

Limited Warranty Claim Procedure.

Claims under these Limited Warranties may be made in writing to **Pella Corporation, Customer Service Department, 102 Main Street, Pella, IA 50219**, by calling for service at 800-374-4758 or by going to <http://warranty.pellaimpervia.com>. Claims to Pella should include the following information:

1. Claimant's name, address and phone number and the installation address (if different);
2. A description of the product, purchase price, date and location of purchase, and copies of invoices;
3. The Pella serial number located on the insulating glass spacer or the unit identification number located on the lower left-hand corner of the glass (as seen from the inside);
4. A description of the product concerns (photos may be included); and
5. A brief summary of attempts made to address the concerns.

Pella may charge a fee for on-site product inspections.

No Statement of Useful Life.

This Limited Warranty is not a statement of the useful life of any Pella® products.

Entire Agreement.

With the exception of a written statement signed by an authorized Pella representative, this Limited Warranty and all the terms contained herein constitutes the entire agreement between Pella/Seller and Buyer/User. This Limited Warranty, including all Limitations of Liability contained herein, is made a part of any such written agreement, unless expressly excluded therein. By purchasing or using the product covered by this Limited Warranty, Buyer/User agrees that they are not relying on any oral statements made by anyone that are in any way contrary to this Limited Warranty.

No Amendment Except in Writing.

Pella and Seller offer this product, and Buyer and User accept it, subject to the foregoing Limited Warranty, which may be modified only by written agreement signed by a duly authorized representative of Pella.

For the most up-to-date warranty information, see the complete warranties for all Pella products on pella.com.

Read the *Pella Impervia Owner's Manual* for the required care and maintenance of your Pella products. All Pella Owner's Manuals are available on pella.com.



February 22, 2019

City of Sheboygan
828 Center Ave.
Suite 205
Sheboygan, WI 53081

Attn: Bernie Rammer

Bernie,

This letter confirms that our installers for this project are employees of Pella Windows and Doors of Wisconsin and have over three years' experience in the installation of commercial grade windows. Listed below are three recent projects that we have completed:

Country Inn & Suites, Appleton WI
Bohemian Park Apartments, Green Bay WI
Menominee County Courthouse, Menominee MI

If you have any questions, please call.

Sincerely,

A handwritten signature in black ink, appearing to read "Rob Coleman".

Rob Coleman
Commercial Sales

Pella Windows & Doors of Wisconsin, a division of VerHalen, Inc.
500 Pilgrim Way
Green Bay, WI 54304
1-800-242-1008
920-435-3791
FAX 920-435-0377

CITY OF SHEBOYGAN

REQUEST FOR LICENSING, HEARINGS & PUBLIC SAFETY CONSIDERATION

ITEM DESCRIPTION: Submitting a communication from Visit Sheboygan making various requests for Sheboygan Concerts and 4th of July events.

REPORT PREPARED BY: Chad Pelishek, Director of Planning and Development

REPORT DATE: April 5, 2019

MEETING DATE: April 10, 2019

FISCAL SUMMARY:

Budget Line Item: N/A
Budget Summary: N/A
Budgeted Expenditure: N/A
Budgeted Revenue: N/A

STATUTORY REFERENCE:

Wisconsin Statutes: N/A
Municipal Code: N/A

BACKGROUND / ANALYSIS:

Visit Sheboygan coordinates on behalf of the City of Sheboygan the 4th of July festivities and concerts in Fountain Park in partnership with the Sheboygan Pops Band. On an annual basis, Visit Sheboygan makes various requests to the city to assist with hosting these events. The City provides public safety services and Public Works services under a celebrations budget.

STAFF COMMENTS:

The Sheboygan Concerts and the 4th of July events are long-running Sheboygan events that benefit both tourists and residents. Having an activity with a community is the key to vibrant community.

ACTION REQUESTED:

Motion to accept and file the communication from Visit Sheboygan making various requests for Sheboygan Concerts and 4th of July events.

ATTACHMENTS:

- I. R.O. No. 243-18-19

II

Other Matters

8.2

R. O. No. 243 - 18 - 19. By CITY CLERK. April 3, 2019.

Submitting a communication from Visit Sheboygan making various requests for Sheboygan Concerts and 4th of July Events.

CITY CLERK

LHPS
+
Public Works

Date: April 1, 2019

To: Meredith DeBruin, City Clerk
City of Sheboygan

Fr: Amy Wilson, President/CEO
Visit Sheboygan, Inc.

Re: Request to Common Council for Sheboygan Concerts and 4th of July Events

Sheboygan Pops Concert Series

Visit Sheboygan requests use of the band shell at Fountain Park and DPW services to setup chairs and dance floor as needed to fulfill its obligation with the city in organizing and implementing the Sheboygan Pops Concert Series.

4th of July

As the coordinator of Sheboygan's 4th of July festivities, including the parade, events at Deland Park, Rotary Park, and South Pier, Visit Sheboygan is requesting use of services and equipment from DPW and police departments. Anticipated resources for the events will be very similar to those utilized in the past, following the schedule below:

Prior to July 4, assistance from DPW is requested to set up picnic tables and benches and staging at Deland Park and South Pier. Following events on July 4, assistance is requested for pick-up of same.

July 3, the fireworks company will be pre-staging fireworks near South Pier. Visit Sheboygan will coordinate location and security of items with the fireworks company, DPW and the Sheboygan Police and Fire Departments.

July 4, assistance with parade logistics and logistics and maintenance of Deland and Rotary Parks and South Pier throughout the day.

Prior to July 4, assistance is requested from the Sheboygan Police Department, blocking off parked traffic for the parade route, as well as assistance routing traffic from the parade on July 4, with assistance controlling traffic throughout the day's festivities. Below is the current schedule of events:

7:00 a.m. Parade Line-up (Route: N. 8th St. at Center Ave., going north to Michigan Ave., East to Broughton Dr.) Note: Parade Permit will be requested as soon as insurance certificate is received by Visit Sheboygan.

- 9:00 a.m. Parade Commences (Note: DPW is requested to set up risers with tables and chairs for six judges at Fountain Park.)
- 11:00 a.m. Deland Park festivities begin. (Entertainment tent with food and beverage sales. Vendor village with food and beverage, arts and crafts vendors, kids' area with inflatable amusements.) Vendor Village ends at 7 p.m. Entertainment breaks for fireworks and ends at 11:00 p.m.
- 12:00 p.m. Rotary Park festivities include on-the-river events, entertainment, and concessions coordinated by Visit Sheboygan. Tentatively free public SUP and Kayak demonstrations, band, and concessions.
- 12:00 p.m. South Pier festivities include a partnership with Angler's Avenue to provide entertainment through the day/evening. Concessions also coordinated by Angler's Avenue.
- 4:00 p.m. Sheboygan Theatre Company performance "A Musical Review," coordinated by the Sheboygan Theatre Company performed in Fountain Park.
- 9:30 p.m. Fireworks display from South Pier.

C: John Motiska, BID Manager
Sue Engler, Blue Harbor Resort Vice President & General Manager
Chief Domagalski, Sheboygan Police Department
Chief Romas, Sheboygan Fire Department
Dave Biebel, Department of Public Works Director
Chad Pelishek, Planning and Development Director

~~X~~

6.1

Gen. Ord. No. 48 - 18 - 19. By Alderpersons Donohue, Sorenson, and Wolf.
March 18, 2019.

AN ORDINANCE amending Sections 58-31 and 58-33 of the Municipal Code to provide that the member of the library board appointed from the common council serve a one-year term.

THE COMMON COUNCIL OF THE CITY OF SHEBOYGAN DO ORDAIN AS FOLLOWS:

Section 1. Section 58-31 of the Sheboygan Municipal Code entitled "Composition" is amended so as to read as follows:

"Sec. 58-31. *Composition.*

The library board shall consist of nine appointed members who shall be citizens and residents of the city. One of the members of the board shall be the superintendent of the public school district of the city or the superintendent's representative to represent the public school district in which the public library is located. One of the members of the board shall be an alderperson."

Section 2. Section 58-33 of the Sheboygan Municipal Code entitled "Terms" is amended so as to read as follows:

"Sec. 58-33. *Terms.*

With the exception of the member appointed from the common council, each member of the library board shall serve as such for a term of three years, each term to commence on May 1 following the appointment. The aldermanic member shall serve for a term of one year, each term to commence on May 1 following the appointment. Should the alderperson appointed to the board no longer hold the position of alderperson, that position shall become vacant, and the mayor may, subject to confirmation by the council, appoint a new aldermanic member to fill the remaining term."

LHDS

Section 3. All ordinances or parts thereof in conflict with the provisions of this ordinance are hereby repealed to the extent of such conflict, and this ordinance shall be in effect upon the commencement of the 2019-2020 council year (April 16, 2019), and after its passage and publication.

By Lynne / Walter

Gene Sauer

I HEREBY CERTIFY that the foregoing Ordinance was duly passed by the Common Council of the City of Sheboygan, Wisconsin, on the _____ day of _____, 20____.

Dated _____ 20____. _____, City Clerk

Approved _____ 20____. _____, Mayor

II

R. O. No. 226 - 18 - 19. By CITY CLERK. March 4, 2019.

Submitting various license applications for the period ending June 30, 2019, December 31, 2019 and June 30, 2020.

City Clerk

CHANGE OF PREMISE (PERMANENT)

| <u>No.</u> | <u>Name</u> | <u>Address</u> |
|------------|---------------------------|--|
| 2949 | Harrys Prohibition Bistro | 668 South Pier Drive - Alcohol will be served within the new constructed walls/barriers patio on the west side of Prohibition Bistro along the boardwalk. All alcohol will be stored inside the building and no alcohol will be left outside after business hours. |

BEVERAGE OPERATOR'S LICENSE (NEW) (June 30, 2020)

| <u>No.</u> | <u>Name</u> | <u>Address</u> |
|------------|------------------------|--|
| 2616 | Birenbaum, Jenipher A. | 1930 N. 7 th Street |
| 2619 | Campbell, Rebecca | 1504 Illinois Avenue |
| 0727 | Fetterer, Aina L. | 4407 Primrose Court #P208 |
| 2622 | Guy, Le'Shay L. | 4918 Windward Court Apt. 16 |
| 2613 | Lietzau, Julie M. | 8512 Pigeon Lake Road, Valders |
| 2403 | Myers, Makai C. | 1207 N. 12 th Street |
| 2617 | Olvera, Juan F. | 718 Superior Avenue |
| 2614 | Raml, Jennifer L. | 2605 N. 9 th Street |
| 2615 | Rutherford, Amy L. | 2220 S. 42 nd Street, Manitowoc |
| 2112 | Schreiner, Kurt | 1231 N. 8 th Street |
| 9913 | Steinberg, Rebecca M. | 1811 N. 3 rd Street |

TAXICAB DRIVERS LICENSE (NEW) (December 31, 2019)

| <u>No.</u> | <u>Name</u> | <u>Address</u> |
|------------|---------------------|-----------------------|
| 2428 | Flunker, Angela S. | 3616 Larkspar Way |
| 0677 | Perez-Velo, Erik F. | 1623 Saemann Avenue |
| 7238 | Schaal, Kelli J. | 1505 St. Clair Avenue |

LHPS

Massage License (NEW) (December 31, 2019)

No. Name

Address

2044 Groove Salon

1227 N. 8th Street

II

Other Matters

7.2

R. O. No. 222 18 - 19. By CITY CLERK. February 18, 2019.

Submitting various license applications for the period ending June 30, 2019, December 31, 2019 and June 30, 2020.

City Clerk

BEVERAGE OPERATOR'S LICENSE (NEW) (June 30, 2020)

| <u>No.</u> | <u>Name</u> | <u>Address</u> |
|------------|-------------------------|---------------------------------------|
| 2592 | Birkholz, Faith G. | W5680 Garton Road, Plymouth |
| 2600 | Bush, Beth A. | 1910 N. 28 th Street |
| 2599 | Guerra, Madeline N. | 730 S. 8 th Street |
| 8604 | Hildreth, Ammber L. | 2311 Hillshire Drive |
| 2598 | Lara-Ruiz, Carley J. | 1708 N. 13 th Street |
| 4182 | Lee, Jollene C. | 427 Wisconsin Avenue |
| 2605 | Looby Jr., Kevin S. | 1620 Alexander Court |
| 2608 | Noss, Shane M. | 2102 Calumet Drive, New Holstein |
| 2597 | Perry Harbert, Nyeim M. | 3501 Lakeshore Road Apt. 2C |
| 0661 | Vanic, Patrick R. | 1205 Stonebridge Drive, Howards Grove |
| 2609 | Wildman, Jonathan J. | 711 Broadway Avenue |
| 2593 | Yonan, Keith S. | 1614 Fox Hill Road |

TAXICAB DRIVERS LICENSE (NEW) (December 31, 2019)

| <u>No.</u> | <u>Name</u> | <u>Address</u> |
|------------|--------------------|------------------------------------|
| 2611 | Kristoff, Seth M. | N3481 E Highway A, Sheboygan Falls |
| 0565 | Krueger, Nathan J. | 13 S. Hiawatha Circle |
| 2434 | Lopez, Angela M. | 4403 Primrose Court Apt. M101 |

"CLASS B" LIQUOR LICENSE (NEW) (June 30, 2019)

| <u>No.</u> | <u>Name</u> | <u>Address</u> |
|------------|-----------------|------------------------|
| 3325 | Power Pubs, LLC | 726 Kiwanis Park Drive |
| 3353 | Rendez-Vous | 920 Michigan Avenue |

YHPS

CLASS "A" LIQUOR LICENSE (June 30, 2019) (NEW)

| <u>No.</u> | <u>Name</u> | <u>Address</u> |
|------------|-------------------|------------------------|
| 3381 | Meijer Store #305 | 924 North Taylor Drive |

CLASS "A" BEER LICENSE (June 30, 2019) (NEW)

| <u>No.</u> | <u>Name</u> | <u>Address</u> |
|------------|-------------------------|------------------------|
| 3382 | Meijer Gas Station #305 | 902 North Taylor Drive |

II

Other Matters

8.1

R. O. No. 242- 18 - 19. By CITY CLERK. April 3, 2019.

Submitting various license applications for the period ending June 30, 2019, December 31, 2019, April 14, 2020 and June 30, 2020.

City Clerk

BEVERAGE OPERATOR'S LICENSE (NEW) (June 30, 2020)

| <u>No.</u> | <u>Name</u> | <u>Address</u> |
|------------|-----------------------------|---|
| 2660 | Carey, Susan M. | 1411 S. 21 st Street |
| 2655 | Dickerson, Danesha D. | 710 Pennsylvania Avenue |
| 2684 | Firgens, Brad M. | 2216 S. 7 th Street |
| 2647 | Forbush, Samantha J. | 725 S. 22 nd Street |
| 2651 | Gartman, Marc R. | 2711 Savannah Circle Apt. C |
| 2653 | Gasbarro, Heather A. | 1197 Edelweiss #18, Sheboygan Falls |
| 2662 | Gunderson, Reuben J. | 633 Torke Terrace, Plymouth |
| 2666 | Grzonka, Stanley G. | 1007 School Avenue #6 |
| 2683 | Harmon, Tearra M. | 1322 Union Avenue |
| 2681 | Hilbelink, Nealy P. | 113 2 nd Street, Sheboygan Falls |
| 2664 | Kesner, Derek S. | 2201 Erie Avenue Apt. B212 |
| 2669 | Kietzman, Jeff J. | 550 Cloverdale Lane, Plymouth |
| 2648 | La France Mara, Veronica M. | 107 Smith Street, Plymouth |
| 1245 | Little, Elizabeth M. | 1606A Indiana Avenue |
| 2658 | Lohse, Jordan R. | 6440 Hidden Fields Court |
| 1803 | Manz, Beth A. | 301 Leavens Avenue, Sheboygan Falls |
| 1111 | Mendez, Samantha L. | 612A Broadway Street, Sheboygan Falls |
| 2650 | Munnik, Bryan A. | W2672 County Road PPP, Sheboygan Falls |
| 2661 | Purtell, Shawn S. | 4730 Moenning Road |
| 2682 | Schleyhahn, John S. | 2617 N. 5 th Street |
| 0232 | Schmidtman, Nancy J. | 3204 N. 26 th Street |
| 2644 | Shinn, Michelle L. | 1519 N. 8 th Street |
| 2667 | Utech, Ian R. | 1526 S. 25 th Street |
| 2645 | Weidner, Mary L. | 902 Pershing Avenue |
| 4808 | Wierikko, Kim M. | 4020 N. 52 nd Street |
| 2659 | Willette, Amanda R. | 1012 Falls Park Dr. #2, Sheboygan Falls |
| 2678 | Woepse, Krystal M. | 110A Monroe Street, Sheboygan Falls |
| 2656 | Yang, Chyra | 1713 Wisconsin Avenue |
| 2670 | Zolecki, Nicholas H. | W55N220 Woodmere Ct. Apt 2, Cedarburg |

LHPS

CHANGE OF AGENT

Ashley Wolf is replacing Darryll D. Matthies as agent effective immediately for Walgreens #6570 - 1029 N. 14th Street.

CHANGE OF PREMISES

| <u>No.</u> | <u>Name</u> | <u>Address</u> |
|------------|-----------------|--|
| 3162 | Sundance Saloon | 1509 S. 12 th Street - to include parking lot east of bar - adjacent to bar. One day event 05/18/19. |
| 1040 | Brennans | 1101 Michigan Avenue - 1101 Michigan Avenue - South parking lot west lot also. One day event 05/05/19. |
| 3150 | Craft 30 | 1015 S. 10 th Street - June 21, 2019- June 23 rd , 2019. Would like the ability to put up tent on green space area outside our patio. Also would allow us to have more patrons and covered area - per weather. |
| 3150 | Craft 30 | 1015 S. 10 th Street - August 10, 2019 - Would like the ability to put up tent on green space area outside our patio. Also would allow us to have more patrons and covered area - per weather. |

CIGARETTE/TOBACCO (June 30, 2019) (NEW)

| <u>No.</u> | <u>Name</u> | <u>Address</u> |
|------------|-----------------|------------------------|
| 3387 | Sheboygan Vapor | 3116 S. Business Drive |

"CLASS B" LIQUOR LICENSE (June 30, 2019) (NEW)

| <u>No.</u> | <u>Name</u> | <u>Address</u> |
|------------|-------------|---------------------------------|
| 3389 | Al & Al's I | 1502 S. 12 th Street |

Sidewalk Café License (Renew) (April 14, 2020)

| <u>No.</u> | <u>Name</u> | <u>Address</u> |
|------------|---------------------------------|---------------------------------|
| 2742 | 8 th Street Ale Haus | 1132 N. 8 th Street |
| 3150 | Craft 30 | 1015 S. 10 th Street |
| 2487 | Frankies Pub & Grill | 2218 Indiana Avenue |

TAXICAB DRIVERS LICENSE (NEW) (December 31, 2019)

| <u>No.</u> | <u>Name</u> | <u>Address</u> |
|------------|--------------------|--------------------------------|
| 2652 | Block, Michelle R. | 414 Niagra Avenue |
| 2668 | Brown, Jason J. | 1028A Superior Avenue |
| 7788 | Degroat, Shawn | 1614 S. 9 th Street |
| 2646 | Miller, Sonya M. | 1318 Virginia Avenue |

II

Other Matters

8.1

R. O. No. 242- 18 - 19. By CITY CLERK. April 3, 2019.

Submitting various license applications for the period ending June 30, 2019, December 31, 2019, April 14, 2020 and June 30, 2020.

City Clerk

BEVERAGE OPERATOR'S LICENSE (NEW) (June 30, 2020)

| <u>No.</u> | <u>Name</u> | <u>Address</u> |
|------------|-----------------------------|---|
| 2660 | Carey, Susan M. | 1411 S. 21 st Street |
| 2655 | Dickerson, Danesha D. | 710 Pennsylvania Avenue |
| 2684 | Firgens, Brad M. | 2216 S. 7 th Street |
| 2647 | Forbush, Samantha J. | 725 S. 22 nd Street |
| 2651 | Gartman, Marc R. | 2711 Savannah Circle Apt. C |
| 2653 | Gasbarro, Heather A. | 1197 Edelweiss #18, Sheboygan Falls |
| 2662 | Gunderson, Reuben J. | 633 Torke Terrace, Plymouth |
| 2666 | Grzonka, Stanley G. | 1007 School Avenue #6 |
| 2683 | Harmon, Tearra M. | 1322 Union Avenue |
| 2681 | Hilbelink, Nealy P. | 113 2 nd Street, Sheboygan Falls |
| 2664 | Kesner, Derek S. | 2201 Erie Avenue Apt. B212 |
| 2669 | Kietzman, Jeff J. | 550 Cloverdale Lane, Plymouth |
| 2648 | La France Mara, Veronica M. | 107 Smith Street, Plymouth |
| 1245 | Little, Elizabeth M. | 1606A Indiana Avenue |
| 2658 | Lohse, Jordan R. | 6440 Hidden Fields Court |
| 1803 | Manz, Beth A. | 301 Leavens Avenue, Sheboygan Falls |
| 1111 | Mendez, Samantha L. | 612A Broadway Street, Sheboygan Falls |
| 2650 | Munnik, Bryan A. | W2672 County Road PPP, Sheboygan Falls |
| 2661 | Purtell, Shawn S. | 4730 Moenning Road |
| 2682 | Schleyhahn, John S. | 2617 N. 5 th Street |
| 0232 | Schmidtman, Nancy J. | 3204 N. 26 th Street |
| 2644 | Shinn, Michelle L. | 1519 N. 8 th Street |
| 2667 | Utech, Ian R. | 1526 S. 25 th Street |
| 2645 | Weidner, Mary L. | 902 Pershing Avenue |
| 4808 | Wierikko, Kim M. | 4020 N. 52 nd Street |
| 2659 | Willette, Amanda R. | 1012 Falls Park Dr. #2, Sheboygan Falls |
| 2678 | Woepse, Krystal M. | 110A Monroe Street, Sheboygan Falls |
| 2656 | Yang, Chyra | 1713 Wisconsin Avenue |
| 2670 | Zolecki, Nicholas H. | W55N220 Woodmere Ct. Apt 2, Cedarburg |

LHPS

CHANGE OF AGENT

Ashley Wolf is replacing Darryll D. Matthies as agent effective immediately for Walgreens #6570 - 1029 N. 14th Street.

CHANGE OF PREMISES

| <u>No.</u> | <u>Name</u> | <u>Address</u> |
|------------|-----------------|--|
| 3162 | Sundance Saloon | 1509 S. 12 th Street - to include parking lot east of bar - adjacent to bar. One day event 05/18/19. |
| 1040 | Brennans | 1101 Michigan Avenue - 1101 Michigan Avenue - South parking lot west lot also. One day event 05/05/19. |
| 3150 | Craft 30 | 1015 S. 10 th Street - June 21, 2019- June 23 rd , 2019. Would like the ability to put up tent on green space area outside our patio. Also would allow us to have more patrons and covered area - per weather. |
| 3150 | Craft 30 | 1015 S. 10 th Street - August 10, 2019 - Would like the ability to put up tent on green space area outside our patio. Also would allow us to have more patrons and covered area - per weather. |

CIGARETTE/TOBACCO (June 30, 2019) (NEW)

| <u>No.</u> | <u>Name</u> | <u>Address</u> |
|------------|-----------------|------------------------|
| 3387 | Sheboygan Vapor | 3116 S. Business Drive |

"CLASS B" LIQUOR LICENSE (June 30, 2019) (NEW)

| <u>No.</u> | <u>Name</u> | <u>Address</u> |
|------------|-------------|---------------------------------|
| 3389 | Al & Al's I | 1502 S. 12 th Street |

Sidewalk Café License (Renew) (April 14, 2020)

| <u>No.</u> | <u>Name</u> | <u>Address</u> |
|------------|---------------------------------|---------------------------------|
| 2742 | 8 th Street Ale Haus | 1132 N. 8 th Street |
| 3150 | Craft 30 | 1015 S. 10 th Street |
| 2487 | Frankies Pub & Grill | 2218 Indiana Avenue |

TAXICAB DRIVERS LICENSE (NEW) (December 31, 2019)

| <u>No.</u> | <u>Name</u> | <u>Address</u> |
|------------|--------------------|--------------------------------|
| 2652 | Block, Michelle R. | 414 Niagra Avenue |
| 2668 | Brown, Jason J. | 1028A Superior Avenue |
| 7788 | Degroat, Shawn | 1614 S. 9 th Street |
| 2646 | Miller, Sonya M. | 1318 Virginia Avenue |

II

Other Matters

8.2

R. O. No. 168 - 18 - 19. By CITY CLERK. November 5, 2018.

Submitting various license applications for the period ending December 31, 2018, June 30, 2019 and June 30, 2020.

City Clerk

"CLASS B" LIQUOR LICENSE (June 30, 2019) (NEW)

| <u>No.</u> | <u>Name</u> | <u>Address</u> |
|------------|-----------------------|---------------------------------|
| 3363 | Pinky's | 2123 N. 15 th Street |
| 3261 | Two Amigos Restaurant | 1119 Michigan Avenue |

BEVERAGE OPERATOR'S LICENSE (NEW) (June 30, 2020)

| <u>No.</u> | <u>Name</u> | <u>Address</u> |
|------------|-------------------------|--|
| 2489 | Adams, Angelica M. | 3515 N. 10 th Street Apt. 421 |
| 2472 | Backus, Holden J. | 523 Pine Street, Sheboygan Falls |
| 2491 | Beam, Christy L. | 244 Center Avenue Apt. 4 |
| 2495 | Boeldt, Adam V. | 615 E. Washington Ave, Cleveland |
| 2471 | Chavez, Edwin G. | 1719 N. 12 th Street |
| 1564 | Derrick, Ricci L. | 1932 N. 10 th Street |
| 9644 | Gischia, Carlo J. | 1916 Martin Avenue |
| 7004 | Halada, Kimberly A. | 2318 S. 16 th Street |
| 1621 | Hameister, Brian L. | 1202 Michigan Avenue Apt. #2 |
| 2484 | Hatleli, Lonnie A. | 1507 S. 8 th Street |
| 2481 | Hernandez, Christina M. | 2705 Wollmer Street, Manitowoc |
| 2478 | Higgins, Destin M. | 2209 N. 29 th Street |
| 2490 | Jackson, Juwaun M. | 918 Georgia Avenue |
| 0706 | Johnson, Marqueeta S. | 1048 Weeden Creek Road |
| 2391 | Lawrence, Michelle L. | 722 Wilson Avenue |
| 2476 | Mahoney, Karen M. | 420 Vanburen Road, Howards Grove |
| 2475 | Maizonet, Susan L. | 929 S. 14 th Street |
| 2485 | Mindock, Ethan C. | 1703 North Avenue |
| 2122 | Mueller, Alexandra A. | 1516 Maryland Avenue |
| 2483 | Neill, Ladonna J. | 2711 S. 8 th Street |
| 7161 | Redinger, Jessica M. | 46 Winnebago Place |
| 6552 | Ross, Stacey M. | 2630 N. 19 th Street |
| 2493 | Solano-Lara, Chase A. | 1909 Martin Avenue |
| 2479 | Thompson, Malikah Y. | 1018 N. 11 th Street |
| 2469 | Warner, Cassandra K. | 1213A S. 8 th Street |
| 2494 | Xiong, Pa Nong | 1715 Ontario Avenue |

AKS

TAXICAB DRIVERS LICENSE (NEW) (December 31, 2018)

| <u>No.</u> | <u>Name</u> | <u>Address</u> |
|------------|-------------------|---------------------------------|
| 3567 | Diener, Kelly J. | 3526 N. 34 th Street |
| 2474 | Neuman, Vivian V. | 2201 Erie Avenue Apt. A102 |